

| ITEM NO. | PART NUMBER | DESCRIPTION | QTY. |
|----------|-------------|----------------------------------|------|
| 1 | 2BARCW | 2BAR UTILITY RACK, CV, W | 1 |
| 2 | SPRMBK4W | MOUNTING KIT-SPRINTER W/OEM RAIL | 1 |
| 3 | PLMDPSMW | PROLIFT,MAX,PS,MR | 1 |
| 4 | PLMDDSMW | PROLIFT,MAX,DS,MR | 1 |

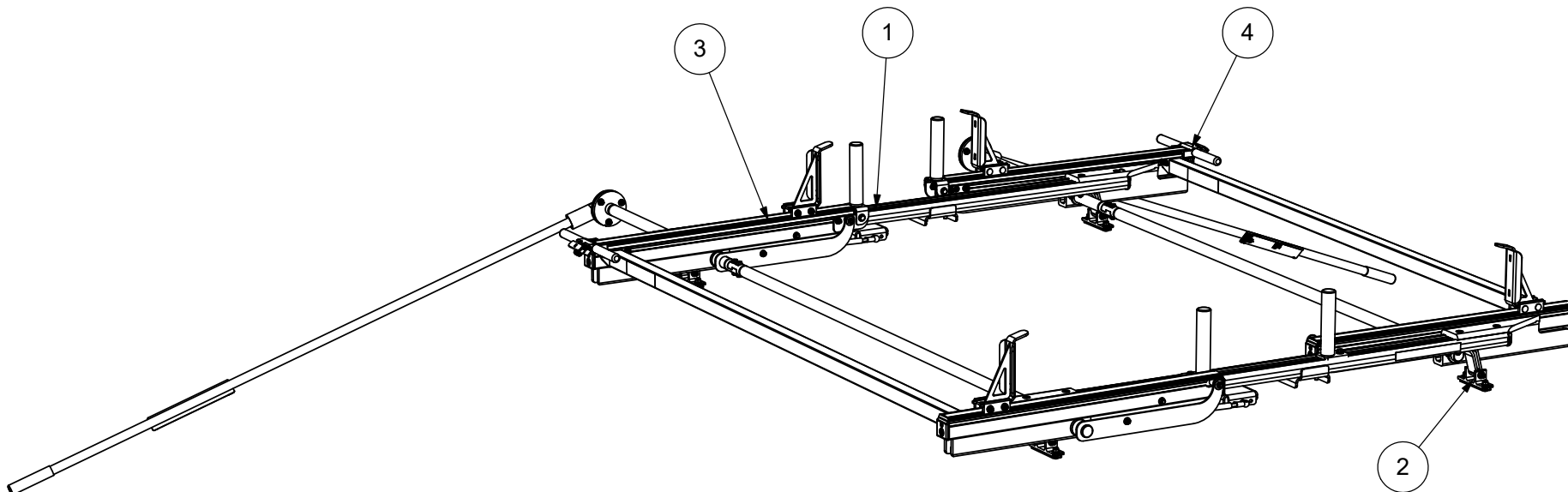

THIS DRAWING IS THE PROPERTY OF ADRIAN STEEL COMPANY AND IS NOT TO BE USED IN ANY MANNER DETRIMENTAL TO THE INTERESTS OF ADRIAN STEEL COMPANY

PRINTED DOCUMENT IS UNCONTROLLED

Sheet 1 of 1

TOLERANCES & INSPECTION

RELEASE & REVISIONS

MATERIAL & FINISH

PART / PRODUCT IDENTIFICATION

UNLESS OTHERWISE SPECIFIED
 ALL BEND ANGLES ARE 90 DEGREES
 ALL DIMENSIONS ARE IN INCHES.
 REFERENCE DIMENSIONS (X.XXX)
 DO NOT REQUIRE INSPECTION

| FEATURES | HOLES/SLOTS | ANGLES |
|----------------|----------------|-------------|
| 0.0 = ± .125 | 0.0 = ± .062 | 0° = ± 2° |
| 0.00 = ± .062 | 0.00 = ± .031 | 0.0° = ± 1° |
| 0.000 = ± .031 | 0.000 = ± .015 | |

Material Thickness: per ASTM Std.
 Weld Callouts per AWS

INITIAL ECN: **25488**

CURRENT ECN: **25488**

ECN DESCRIPTION:
RELEASE FOR PRODUCTION

REVISED BY:

MECHANICAL FINISHING:
N/A

PRIMER: **N/A**

FINAL FINISH: **NONE NONE**

Paint Weight: N/A

MATERIAL TYPE: **ASSM**

| | | |
|---|---------------------------------|------------------------------|
| ADRIAN STEEL ADRIAN STEEL COMPANY 906 JAMES STREET, ADRIAN, MI 49221 | | REVISION LEVEL |
| | | A |
| MAT'L USED: ASSM | DESIGNED BY: B.Southward | |
| DESCRIPTION: DBL MAX-DROP DOWN SPRINTER 144 LR-OEM RAIL | | |
| WEIGHT (Lbs.): 163.91 | SEGMENT CODE: VLR | PART NUMBER: PLM63SPO |