

ITEM NO.	PART NUMBER	DESCRIPTION	QTY.
1	2BARCW	2BAR UTILITY RACK, CV, W	1
2	SPRMBK4W	MOUNTING KIT-SPRINTER W/OEM RAIL	1
3	PLMDPSMW	PROLIFT,MAX,PS,MR	1

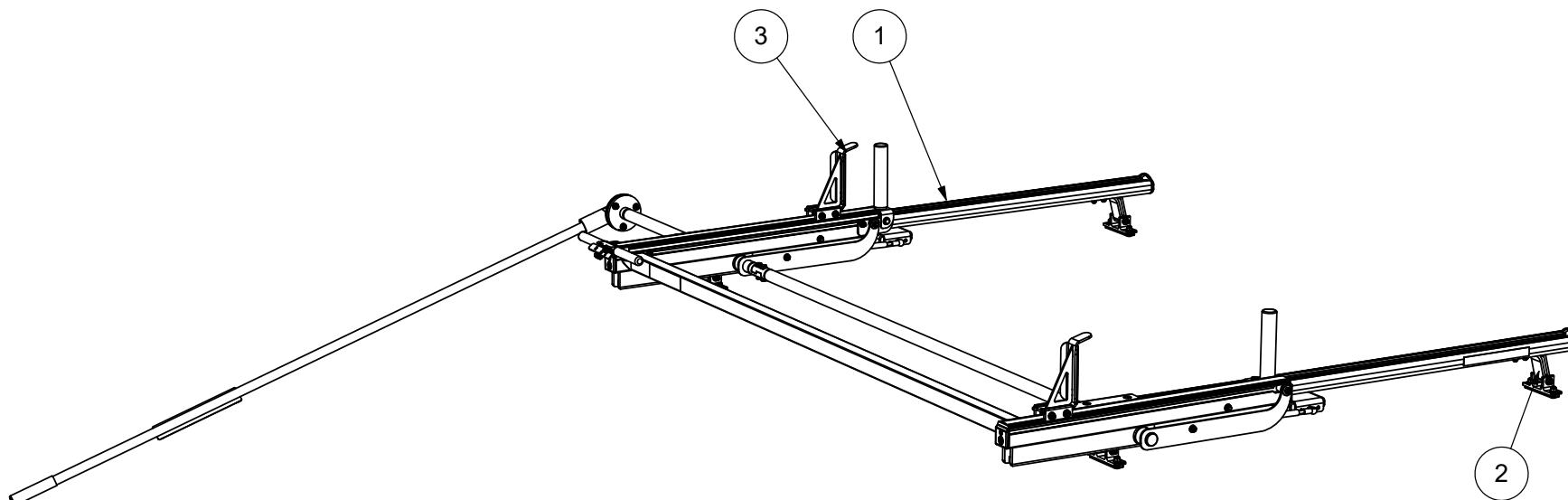

THIS DRAWING IS THE PROPERTY OF ADRIAN STEEL COMPANY AND IS NOT TO BE USED IN ANY MANNER DETRIMENTAL TO THE INTERESTS OF ADRIAN STEEL COMPANY

PRINTED DOCUMENT IS UNCONTROLLED

Sheet 1 of 1

TOLERANCES & INSPECTION

RELEASE & REVISIONS

MATERIAL & FINISH

PART / PRODUCT IDENTIFICATION

UNLESS OTHERWISE SPECIFIED
ALL BEND ANGLES ARE 90 DEGREES
ALL DIMENSIONS ARE IN INCHES.
REFERENCE DIMENSIONS (X.XXX)
DO NOT REQUIRE INSPECTION

FEATURES	HOLES/SLOTS	ANGLES
0.0 = ± .125	0.0 = ± .062	0° = ± 2°
0.00 = ± .062	0.00 = ± .031	0.0° = ± 1°
0.000 = ± .031	0.000 = ± .015	

Material Thickness: per ASTM Std.
Weld Callouts per AWS

INITIAL ECN: **25488**

CURRENT ECN: **25488**

ECN DESCRIPTION:
RELEASE FOR PRODUCTION

REVISED BY:

MECHANICAL FINISHING:
N/A

PRIMER: **N/A**

FINAL FINISH: **NONE NONE**

Paint Weight: N/A

MATERIAL TYPE: **ASSM**

ADRIAN STEEL ADRIAN STEEL COMPANY 906 JAMES STREET, ADRIAN, MI 49221		REVISION LEVEL A
MAT'L USED: ASSM	DESIGNED BY: BDS	
DESCRIPTION: SGL MAX-DROP DOWN SPRINTER 144 LR-OEM RAIL		
WEIGHT (Lbs.): 93.27	SEGMENT CODE: VLR	PART NUMBER: PLM61SPO