

ITEM NO.	PART NUMBER	DESCRIPTION	QTY.
1	URMBK4W	UTILTY,MNT BKT KT,RAIL,4W	1
2	PLMDPSHW	PROLIFT,MAX,PS,HR,W	1
3	RRKSP	ROOF RAIL KIT, SPRINTER FSV	1
4	2BARCW	2BAR UTILITY RACK, CV, W	1

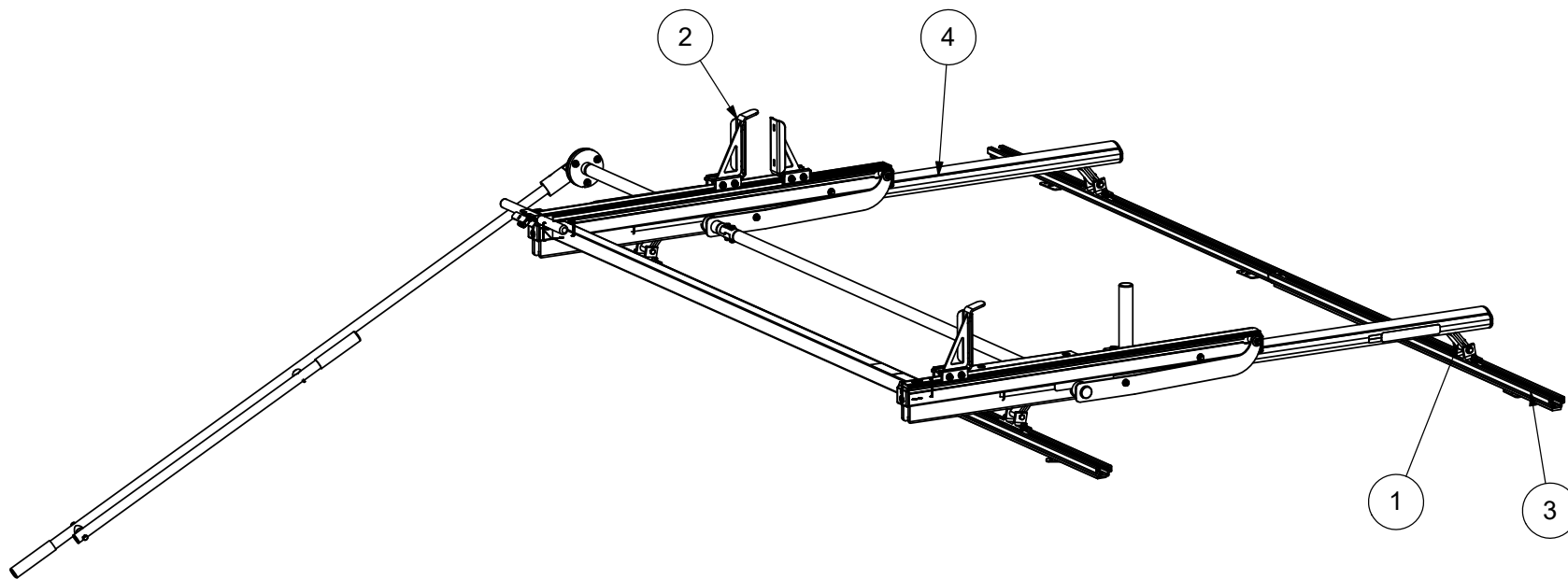

THIS DRAWING IS THE PROPERTY OF ADRIAN STEEL COMPANY AND IS NOT TO BE USED IN ANY MANNER DETRIMENTAL TO THE INTERESTS OF ADRIAN STEEL COMPANY

### MATERIAL & FINISH

PRINTED DOCUMENT IS UNCONTROLLED

Sheet 1 of 1

### TOLERANCES & INSPECTION

### RELEASE & REVISIONS

### MATERIAL & FINISH

### PART / PRODUCT IDENTIFICATION

UNLESS OTHERWISE SPECIFIED  
ALL BEND ANGLES ARE 90 DEGREES  
ALL DIMENSIONS ARE IN INCHES.  
REFERENCE DIMENSIONS (X.XXX)  
DO NOT REQUIRE INSPECTION

FEATURES	HOLES/SLOTS	ANGLES
0.0 = ± .125	0.0 = ± .062	0° = ± 2°
0.00 = ± .062	0.00 = ± .031	0.0° = ± 1°
0.000 = ± .031	0.000 = ± .015	

Material Thickness: per ASTM Std.  
Weld Callouts per AWS

INITIAL ECN: **22817**

CURRENT ECN: **23407**

ECN DESCRIPTION:  
**Replace 2BARW with 2BARCW**

REVISED BY: B.Southward

MECHANICAL FINISHING:  
**N/A**

PRIMER: **N/A**

FINAL FINISH: **NONE NONE**

**Paint Weight: N/A**

MATERIAL TYPE: **ASSM**

 <b>ADRIAN STEEL</b> <sup>®</sup>		ADRIAN STEEL COMPANY 906 JAMES STREET, ADRIAN, MI 49221		REVISION LEVEL
				<b>B</b>
MAT'L USED:	<b>ASSM</b>	DESIGNED BY:	<b>B.Southward</b>	
DESCRIPTION:	<b>Passenger Side Max-Drop Prolift Sprinter HR</b>			
WEIGHT (Lbs.):	<b>127</b>	SEGMENT CODE:	<b>VLR</b>	
		PART NUMBER:	<b>PLM61SPH</b>	