

ITEM NO.	PART NUMBER	DESCRIPTION	QTY.
1	2BARCW	2BAR UTILITY RACK, CV, W	1
2	GL-FSVPS	GRIP LOCK FULL SIZE VEHICLE PASSENGER SIDE	1
3	GMMBK4W	UTILITY,MNT BKT KT,GM,4,W	1

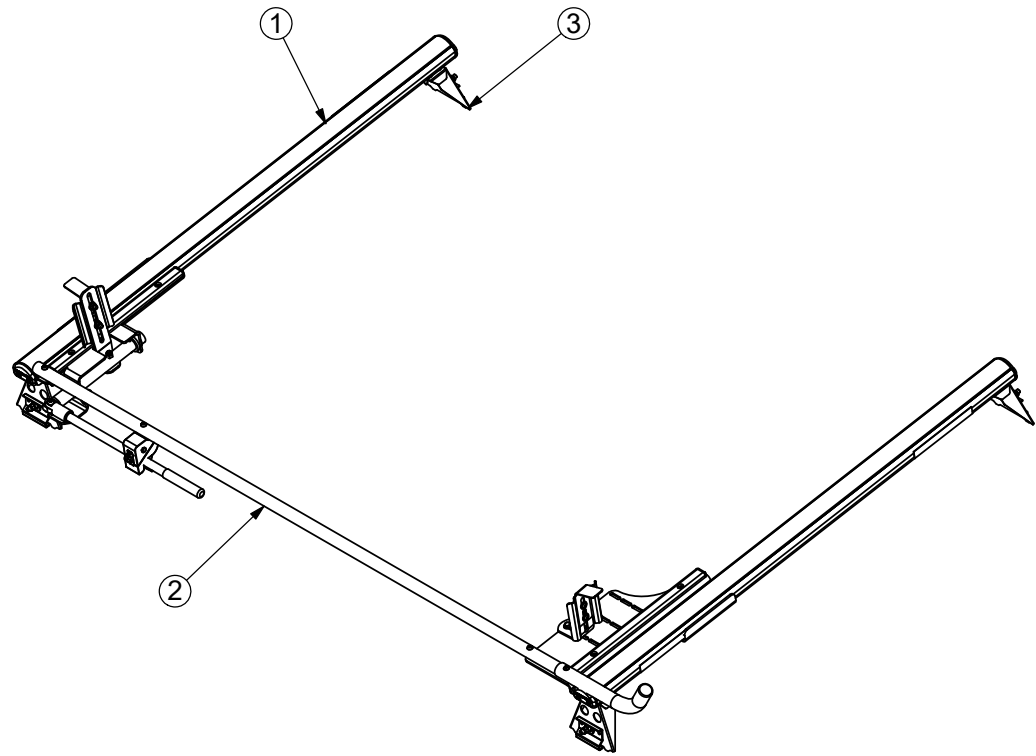

THIS DRAWING IS THE PROPERTY OF ADRIAN STEEL COMPANY AND IS NOT TO BE USED IN ANY MANNER DETRIMENTAL TO THE INTERESTS OF ADRIAN STEEL COMPANY

PRINTED DOCUMENT IS UNCONTROLLED

Sheet 1 of 1

TOLERANCES & INSPECTION

RELEASE & REVISIONS

MATERIAL & FINISH

PART / PRODUCT IDENTIFICATION

UNLESS OTHERWISE SPECIFIED
 ALL BEND ANGLES ARE 90 DEGREES
 ALL DIMENSIONS ARE IN INCHES.
 REFERENCE DIMENSIONS (X.XXX)
 DO NOT REQUIRE INSPECTION

FEATURES	HOLES/SLOTS	ANGLES
0.0 = ± .125	0.0 = ± .062	0° = ± 2°
0.00 = ± .062	0.00 = ± .031	0.0° = ± 1°
0.000 = ± .031	0.000 = ± .015	

Material Thickness: per ASTM Std.
 Weld Callouts per AWS

INITIAL ECN: **25488**

CURRENT ECN: **25488**

ECN DESCRIPTION:
RELEASE FOR PRODUCTION

REVISED BY:

MECHANICAL FINISHING:
N/A

PRIMER: **N/A**

FINAL FINISH: **NONE NONE**

Paint Weight: N/A

MATERIAL TYPE: **ASSM**

 ADRIAN STEEL®		ADRIAN STEEL COMPANY 906 JAMES STREET, ADRIAN, MI 49221	REVISION LEVEL <h1>A</h1>
MAT'L USED:	ASSM	DESIGNED BY:	BDS
DESCRIPTION: SINGLE GRIP LOCK GM FSV			
WEIGHT (Lbs.):	58.7	SEGMENT CODE:	VLR
		PART NUMBER:	GL61GM