

ITEM NO.	PART NUMBER	DESCRIPTION	QTY.
1	2BARW	2BAR UTILITY RACK, FSV, W	1
2	RSK1B	UTILITY, RATCHET KIT, 1B	4
3	ULSKB	UTILITY, LADDER STOP KIT	1

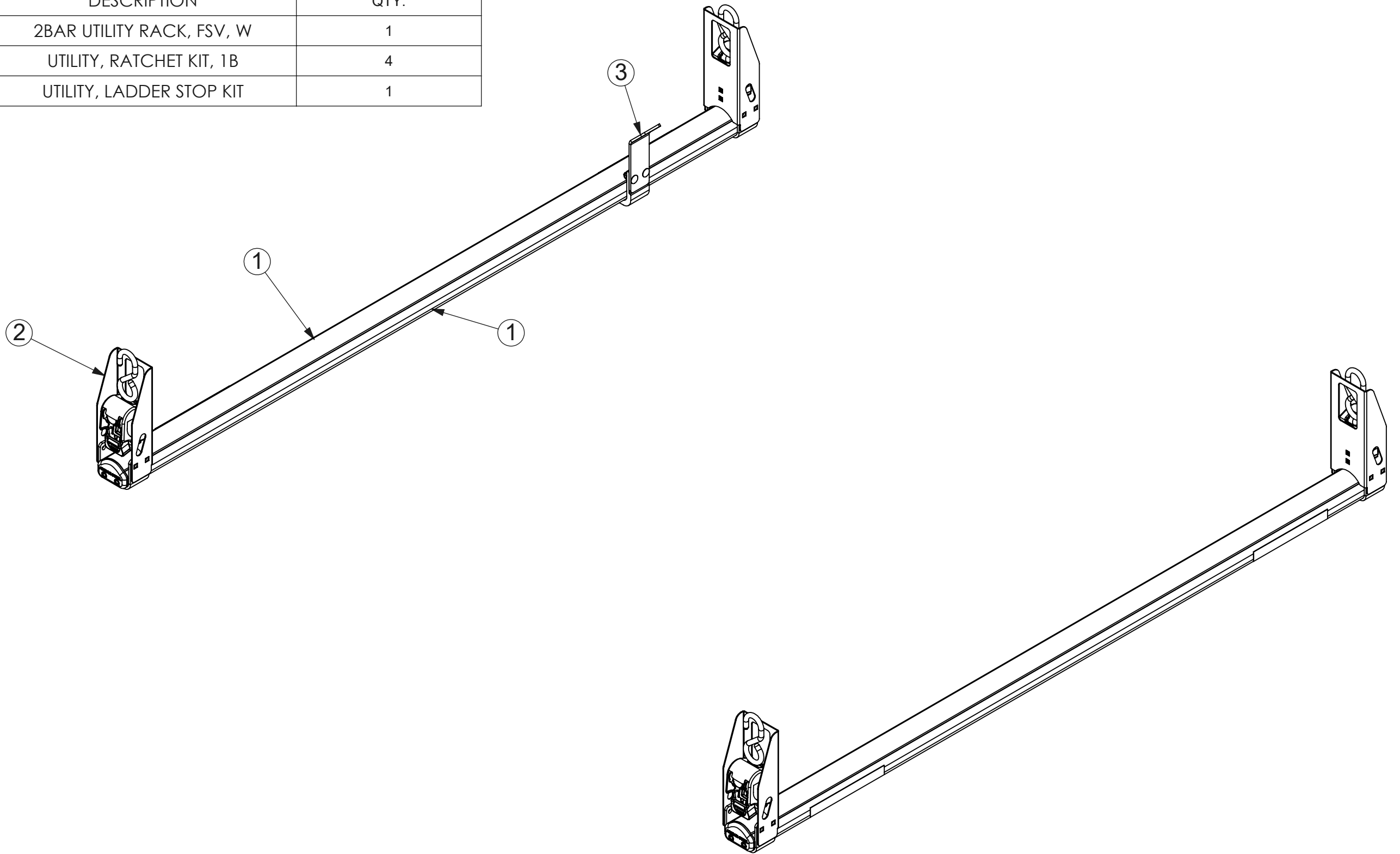

THIS DRAWING IS THE PROPERTY OF ADRIAN STEEL COMPANY AND IS NOT TO BE USED IN ANY MANNER DETRIMENTAL TO THE INTERESTS OF ADRIAN STEEL COMPANY

PRINTED DOCUMENT IS UNCONTROLLED

Sheet 1 of 1

TOLERANCES & INSPECTION

RELEASE & REVISIONS

MATERIAL & FINISH

PART / PRODUCT IDENTIFICATION

UNLESS OTHERWISE SPECIFIED
 ALL BEND ANGLES ARE 90 DEGREES
 ALL DIMENSIONS ARE IN INCHES.
 REFERENCE DIMENSIONS (X.XXX)
 DO NOT REQUIRE INSPECTION

FEATURES	HOLES/SLOTS	ANGLES
0.0 = ± .125	0.0 = ± .062	0° = ± 2°
0.00 = ± .062	0.00 = ± .031	0.0° = ± 1°
0.000 = ± .031	0.000 = ± .015	

Material Thickness: per ASTM Std.
 Weld Callouts per AWS

INITIAL ECN: **25146**
 CURRENT ECN: **25146**
 ECN DESCRIPTION:
RELEASE FOR PRODUCTION
 REVISED BY: **N/A**

MECHANICAL FINISHING:
N/A
 PRIMER: **N/A**
 FINAL FINISH: **NONE**
Paint Weight: N/A
 MATERIAL TYPE: **ASSM**

 ADRIAN STEEL®		ADRIAN STEEL COMPANY 906 JAMES STREET, ADRIAN, MI 49221	REVISION LEVEL A
MAT'L USED: ASSEMBLY	DESIGNED BY: Z. BURK		
DESCRIPTION: 2BAR FSV, 9" RATCHETS, W			
WEIGHT (Lbs.): 32.80	SEGMENT CODE: VLR	PART NUMBER: 2B9RW	