

ITEM NO.	PART NUMBER	DESCRIPTION	QTY.
1	2BARCW	2BAR UTILITY RACK, CV, W	1
2	RSK1B	UTILITY, RATCHET KIT, 1B	4
3	ULSKB	UTILITY, LADDER STOP KIT	1

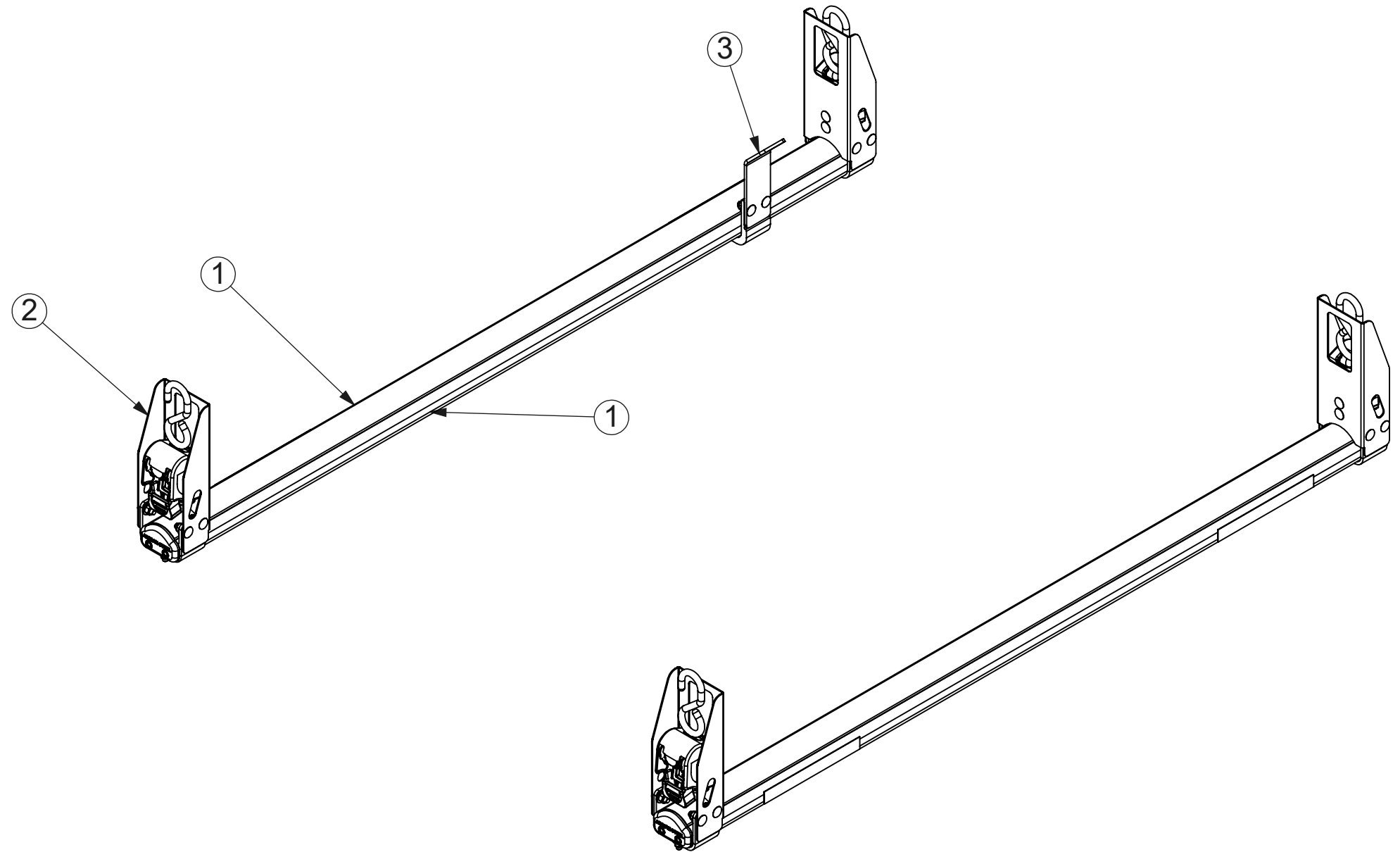

THIS DRAWING IS THE PROPERTY OF ADRIAN STEEL COMPANY AND IS NOT TO BE USED IN ANY MANNER  
DETRIMENTAL TO THE INTERESTS OF ADRIAN STEEL COMPANY

PRINTED DOCUMENT IS UNCONTROLLED

Sheet 1 of 1

TOLERANCES & INSPECTION		
UNLESS OTHERWISE SPECIFIED		
ALL BEND ANGLES ARE 90 DEGREES		
ALL DIMENSIONS ARE IN INCHES.		
REFERENCE DIMENSIONS (X.XXX) DO NOT REQUIRE INSPECTION		
FEATURES	HOLES/SLOTS	ANGLES
0.0 = ± .125	0.0 = ± .062	0° = ± 2°
0.00 = ± .062	0.00 = ± .031	0.0° = ± 1°
0.000 = ± .031	0.000 = ± .015	
Material Thickness: per ASTM Std. Weld Callouts per AWS		

RELEASE & REVISIONS
INITIAL ECN: 25146
CURRENT ECN: 25146
ECN DESCRIPTION: <b>RELEASE FOR PRODUCTION</b>
REVISED BY: N/A

MATERIAL & FINISH
MECHANICAL FINISHING: <b>N/A</b>
PRIMER: <b>N/A</b>
FINAL FINISH: <b>NONE NONE</b>
<b>Paint Weight: N/A</b>
MATERIAL TYPE: <b>ASSM</b>

PART / PRODUCT IDENTIFICATION		
 <b>ADRIAN STEEL</b> <sup>®</sup>		ADRIAN STEEL COMPANY 906 JAMES STREET, ADRIAN, MI 49221
MAT'L USED: <b>ASSEMBLY</b>	DESIGNED BY: <b>Z. BURK</b>	REVISION LEVEL <b>A</b>
DESCRIPTION: <b>2BAR COMP, 9" RATCHETS, W</b>		
WEIGHT (Lbs.): <b>29.836</b>	SEGMENT CODE: <b>VLR</b>	PART NUMBER: <b>2B9RCW</b>