

INSTR. NUMBER : 71622

PG: 1 REV: R

**BOM FOR 6.5' F-150**

PART NUMBER : TFK\_\_T178HM23W

PART DESC. : ASM INS, TFK\_\_T178HM23W

ITEM NO.	PART NUMBER	DESCRIPTION	QTY.
1	TSK78M23W	TOP, SIDE KIT,78",M,23,W	2
2	TCK78HM23W	TOP,CLOSE KIT,78",HM23,W	1
3	TRK7823W	TOP, ROOF KIT,78",23,W	1
4	THKFDT178M23	HDW KIT, TFKFDT178HM23W	1
5	TMLHK	Topper Mechanical Lock Hatch Kit	1

**\* E-LOCK VERSION SWAP TMLHK WITH TELH05**

**BOM FOR 6.5' SILVERADO 1500**

ITEM NO.	PART NUMBER	DESCRIPTION	QTY.
1	TSK78M23W	TOP, SIDE KIT,78",M,23,W	2
2	TCK78HM23W	TOP,CLOSE KIT,78",HM23,W	1
3	TRK7823W	TOP, ROOF KIT,78",23,W	1
4	THKGMT178M23	HDW KIT, TFKGMT178HM23W	1
5	TMLHK	Topper Mechanical Lock Hatch Kit	1

**\* E-LOCK VERSION SWAP TMLHK WITH TELH02**

**NOTE: THESE INSTRUCTIONS ARE VALID FOR ALL TFK FULL TOPPER KITS. A FEW BOM KITS ARE SHOWN FOR REFERENCE ONLY.**

**INSTRUCTIONS SHOWS F-150 BODY DURING INSTALLATION**

**FASTENER AND HOLE COUNTS MAY BE DIFFERENT BETWEEN TOPPER KITS.**

**E-LOCK VERSIONS:  
SWAP M WITH E IN PART NUMBER  
EXAMPLE: TFKFDT178HM23W  
BECOMES TFKFDT178HE23W**

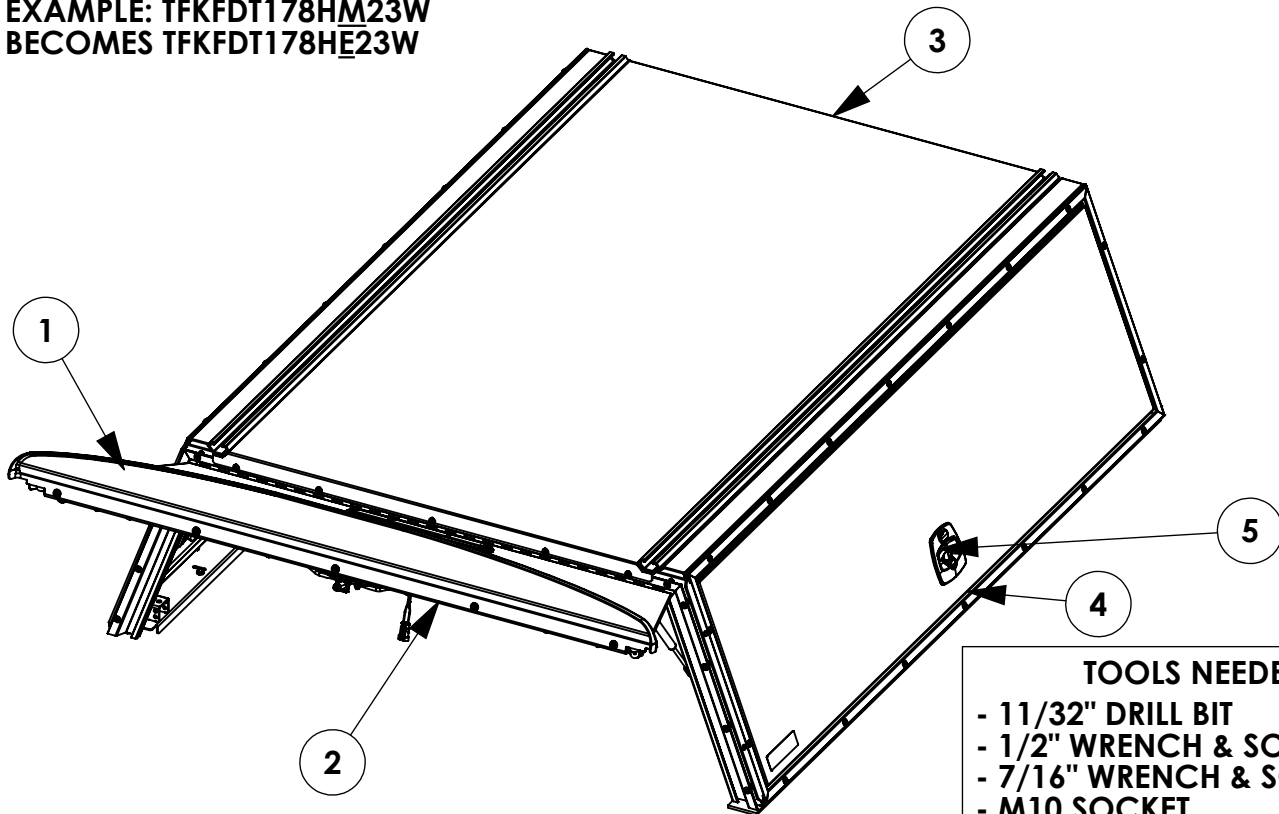

**TOOLS NEEDED:**

- 11/32" DRILL BIT
- 1/2" WRENCH & SOCKET
- 7/16" WRENCH & SOCKET
- M10 SOCKET
- M8 SOCKET
- M4 ALLEN
- 3/16" ALLEN
- 5/32" ALLEN
- DRIVE RATCHET / IMPACT
- SCISSORS
- TAPE MEASURE
- ALIGNMENT PUNCH

INSTR. : 71622  
 NUMBER : 71622

PG: 2  
 REV: R

PART : TFK\_\_T178HM23W  
 NUMBER : TFK\_\_T178HM23W

PART :  
 DESC. : ASM INS, TFK\_\_T178HM23W

**E-LOCK VERSIONS:  
 SWAP M WITH E IN PART NUMBER  
 EXAMPLE: TFKFDT178HM23W  
 BECOMES TFKFDT178HE23W**

**BOM FOR 6.3' RAM**

ITEM NO.	PART NUMBER	DESCRIPTION	QTY.
1	TCK78HM23W	TOP,CLOSE KIT,78",HM23,W	1
2	THKRAM175M23	HDW KIT, TCKRAMT175HM23W	1
3	TRK7523W	TOP, ROOF PANEL KIT, RAM	1
4	TSK75M23W	TOP, SIDE KIT, 78" RAM	2
5	TMLHK	Topper Mechanical Lock Hatch Kit	1

**\* E-LOCK VERSION SWAP TMLHK WITH TELH02**

**BOM FOR 5.7' RAM**

ITEM NO.	PART NUMBER	DESCRIPTION	QTY.
1	TSK66M23W	TOP, SIDE KIT,66",M,23,W	2
2	TCK78HM23W	TOP,CLOSE KIT,78",HM23,W	1
3	TRK6623W	TOP, ROOF KIT,66",23,W	1
4	THKRAM167M23	HDW KIT, TFKRAM167HM23W	1
5	TMLHK	Topper Mechanical Lock Hatch Kit	1

**\* E-LOCK VERSION SWAP TMLHK WITH TELH01**

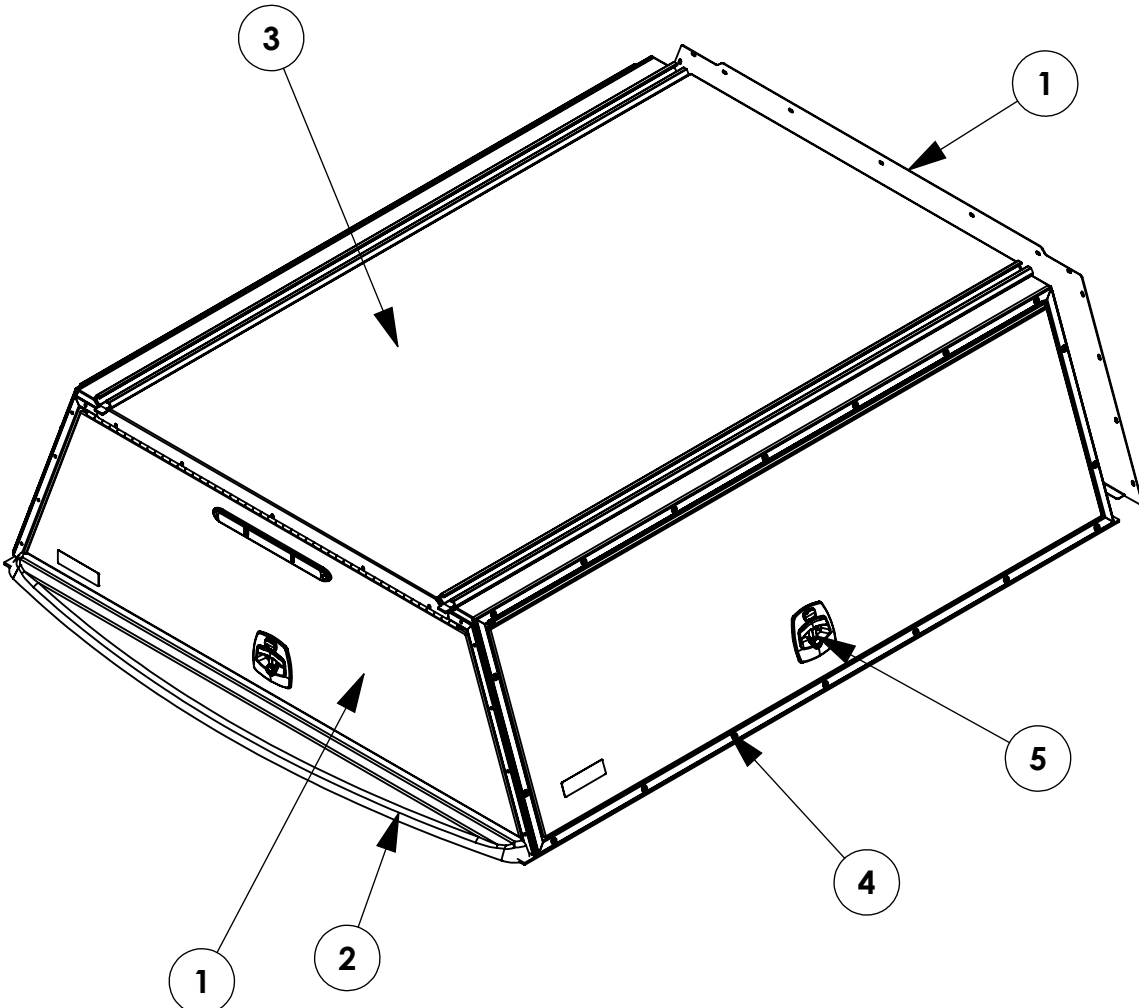

INSTR. NUMBER : <b>71622</b>	PG: <b>3</b>	REV: <b>R</b>
PART NUMBER : <b>TFK__T196HM23W</b>		
PART DESC. : ASM INS, TFK__T178HM23W		

**E-LOCK VERSIONS:  
SWAP M WITH E IN PART NUMBER  
EXAMPLE: TFKFDT178HM23W  
BECOMES TFKFDT178HE23W**

**BOM FOR 8.0' 23" TALL FORD F-150, F-250, F-350**

ITEM NO.	PART NUMBER	DESCRIPTION	QTY.
1	TSK96M23W	TOP, SIDE KIT,96",M,23,W	2
2	TCK78HM23W	TOP,CLOSE KIT,78",HM23,W	1
3	TRK9623W	TOP, ROOF KIT,96",23,W	1
4	THKFDT196M23	HDW KIT, TFKFDT196HM23W	1
5	TMLHK	Topper Mechanical Lock Hatch Kit	1

**\* E-LOCK VERSION SWAP TMLHK WITH TELH06**

**BOM FOR 8.0' 23" TALL SILVERADO 1500, 2500, 3500**

ITEM NO.	PART NUMBER	DESCRIPTION	QTY.
1	TSK96M23W	TOP, SIDE KIT,96",M,23,W	2
2	TCK78HM23W	TOP,CLOSE KIT,78",HM23,W	1
3	TRK9623W	TOP, ROOF KIT,96",23,W	1
4	THKGMT196M23	HDW KIT, TFKGMT196HM23W	1
5	TMLHK	Topper Mechanical Lock Hatch Kit	1

**\* E-LOCK VERSION SWAP TMLHK WITH TELH03**

**BOM FOR 8.0' 23" TALL RAM 1500, 2500, 3500**

ITEM NO.	PART NUMBER	DESCRIPTION	QTY.
1	TSK96M23W	TOP, SIDE KIT,96",M,23,W	2
2	TCK78HM23W	TOP,CLOSE KIT,78",HM23,W	1
3	TRK9623W	TOP, ROOF KIT,96",23,W	1
4	THKRAM196M23	HDW KIT, TFKRAM196HM23W	1
5	TMLHK	Topper Mechanical Lock Hatch Kit	1

**\* E-LOCK VERSION SWAP TMLHK WITH TELH03**

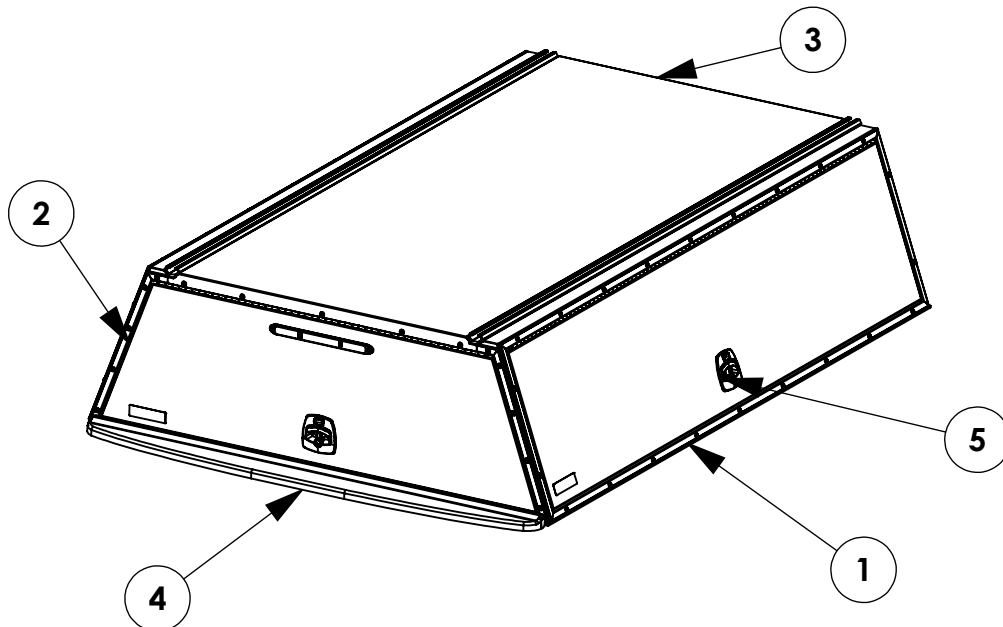

INSTR. NUMBER : <b>71622</b>		PG: <b>4</b>	REV: <b>R</b>	<b>BOM FOR 8.0' 26" TALL FORD F-150, F-250, F-350</b>			
PART NUMBER : <b>TFK__T296HM26W</b>				ITEM NO.	PART NUMBER	DESCRIPTION	QTY.
PART DESC. : ASM INS, TFK__T178HM23W				1	TSK96M26W	TOP, SIDE KIT,96",M,26,W	2
				2	TCK80HM26W	TOP,CLOSE KIT,80",HM263,W	1
				3	TRK9623W	TOP, ROOF KIT,96",23,W	1
				4	THKFDT296M26	HDW KIT, TFKFDT296HM26W	1
				5	TMLHK	Topper Mechanical Lock Hatch Kit	1

**E-LOCK VERSIONS:**  
**SWAP M WITH E IN PART NUMBER**  
**EXAMPLE: TFKFDT178HM23W**  
**BECOMES TFKFDT178HE23W**

**\* E-LOCK VERSION SWAP TMLHK WITH TELH06**

**BOM FOR 8.0' 26" TALL SILVERADO 1500, 2500, 3500**

ITEM NO.	PART NUMBER	DESCRIPTION	QTY.
1	TSK96M26W	TOP, SIDE KIT,96",M,26,W	2
2	TCK80HM26W	TOP,CLOSE KIT,80",HM263,W	1
3	TRK9623W	TOP, ROOF KIT,96",23,W	1
4	THKGMT296M26	HDW KIT, TFKGMT296HM26W	1
5	TMLHK	Topper Mechanical Lock Hatch Kit	1

**\* E-LOCK VERSION SWAP TMLHK WITH TELH03**



**BOM FOR 8.0' 26" TALL RAM 1500, 2500, 3500**  
**NOTE: SPECIAL ASSEMBLY INSTRUCTION SHOWN ON SHEET 20**

ITEM NO.	PART NUMBER	DESCRIPTION	QTY.
1	TSK96M26W	TOP, SIDE KIT,96",M,26,W	2
2	TCK80HM26W	TOP,CLOSE KIT,80",HM263,W	1
3	TRK9623W	TOP, ROOF KIT,96",23,W	1
4	THKRAM296M26	HDW KIT, TFKRAM296HM26W	1
5	TMLHK	Topper Mechanical Lock Hatch Kit	1

**\* E-LOCK VERSION SWAP TMLHK WITH TELH03**

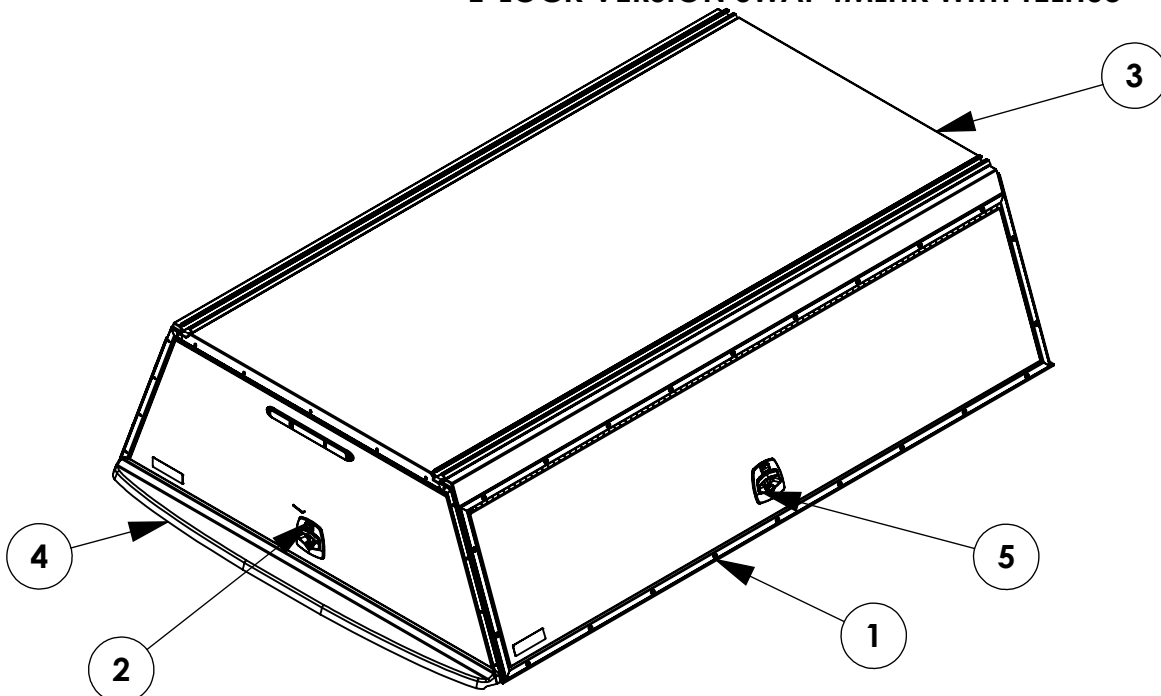

INSTR. : 71622  
NUMBER :  
PG: 5  
REV: R

PART : TFKFDT166HM23W  
NUMBER :

PART :  
DESC. : ASM INS, TFK\_\_T178HM23W

**E-LOCK VERSION: TFKFDT166HE23W**

**BOM FOR 5.5' 23" TALL FORD F-150 LIGHTNING/ICE**

ITEM NO.	PART NUMBER	DESCRIPTION	QTY.
1	TSK66M23W	TOP, SIDE KIT,66",M,23,W	2
2	TCK78HM23W	TOP,CLOSE KIT,78",HM23,W	1
3	TRK6623W	TOP, ROOF KIT,66",23,W	1
4	THKFDT166M23	HDW KIT, TFKFDT166HM23W	1
5	TMLHK	Topper Mechanical Lock Hatch Kit	1

**\* E-LOCK VERSION SWAP TMLHK WITH TELH04**

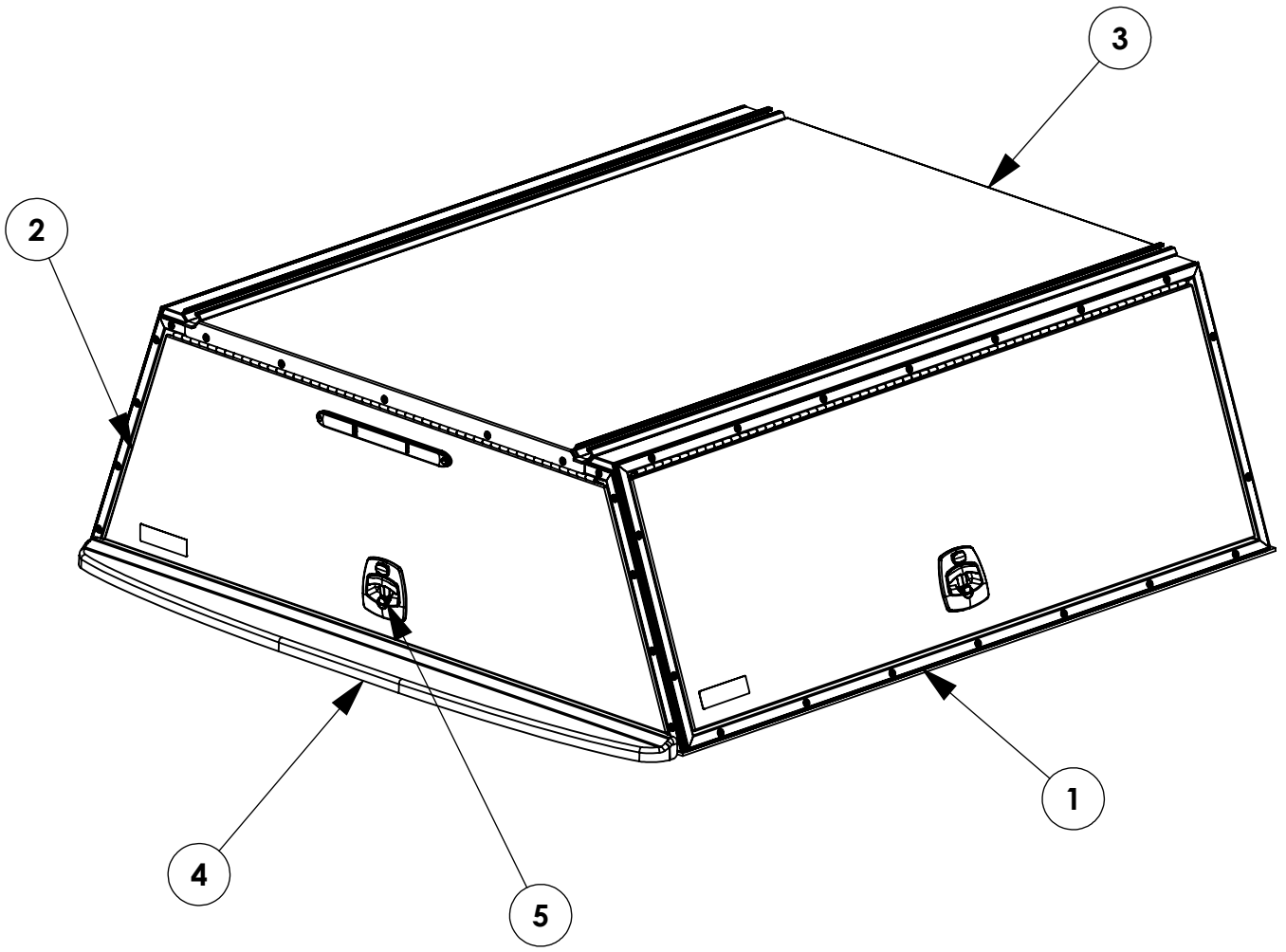

INSTR. NUMBER : <b>71622</b>		PG: <b>6</b>	REV: <b>R</b>	<b>BOM FOR 5' FORD RANGER</b>		
PART NUMBER : <b>TFKRNG160HM23W</b>		ITEM NO.	PART NUMBER	DESCRIPTION	QTY.	
PART DESC. : ASM INS, TFK__T178HE23W		1	TSKRNG60M23W	TOP, SIDE KIT, 60", RANGER, M, 23, W	2	
		2	TCK72HM23W	TOP, CLOSE KIT, 72", HM23, W	1	
		3	TRK6023W	TOP, ROOF KIT, 60", 23, W	1	
		4	THKRNG160M23	HDW KIT, TFKNFT172HM23W	1	
		5	TMLHK	TOPPER MECHANICAL LOCK HATCH KIT	1	

**E-LOCK VERSION: TFKRNG160HE23W**

**\* E-LOCK VERSION SWAP TMLHK WITH TELH04**

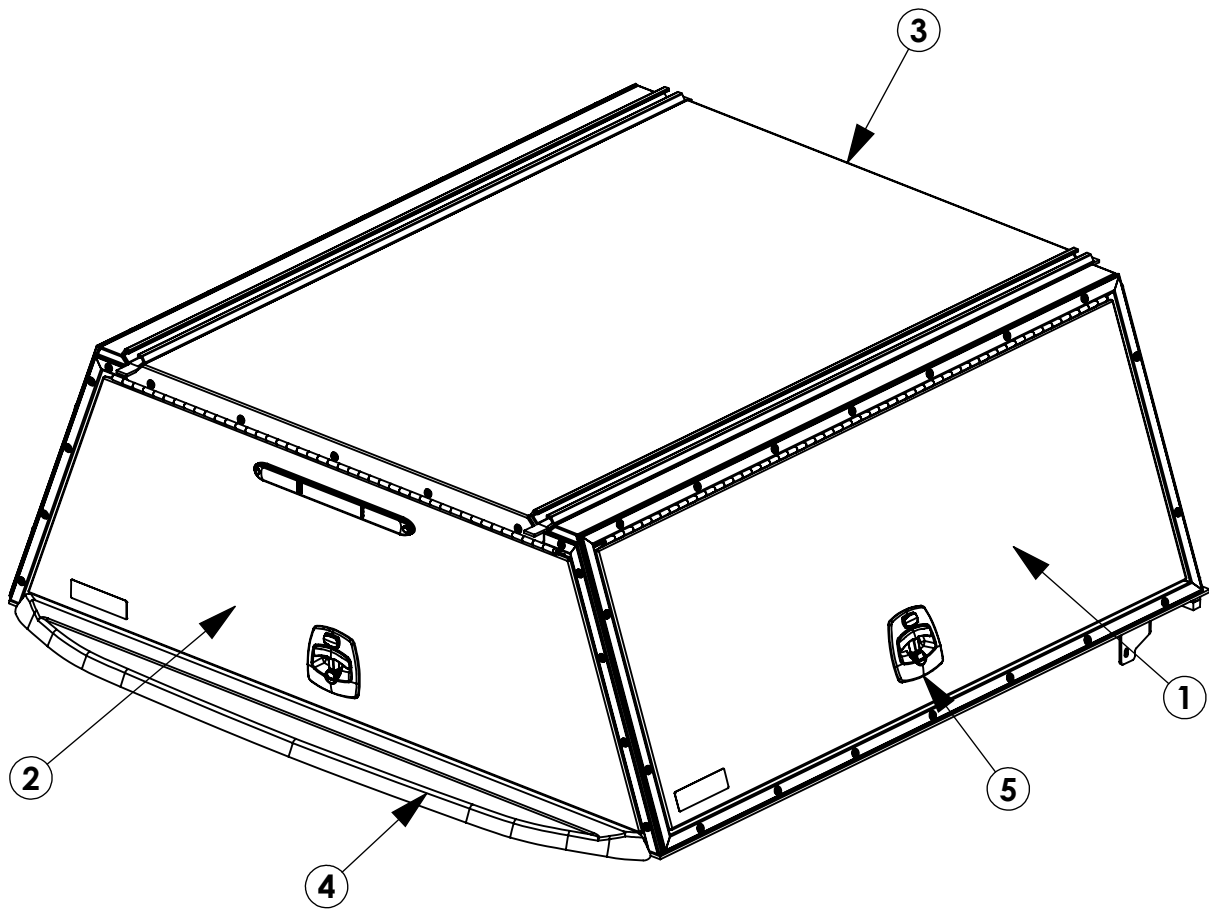

INSTR. NUMBER : **71622**

PG: **7** REV: **R**

PART NUMBER : **TFKNFT172HM23W**

PART DESC. : ASM INS, TFK\_\_T178HM23W

**BOM FOR 6.0' 23" TALL NISSAN FRONTIER**

ITEM NO.	PART NUMBER	DESCRIPTION	QTY.
1	TSK72M23W	TOP, SIDE KIT,72",M,23,W	2
2	TCK72HM23W	TOP,CLOSE KIT,72",HM23,W	1
3	TRK7223W	TOP, ROOF KIT,72",23,W	1
4	THKNFT172M23	HDW KIT, TFKNFT172HM23W	1
5	TMLHK	Topper Mechanical Lock Hatch Kit	1

**E-LOCK VERSION: TFKNFT172HE23W**

**\* E-LOCK VERSION SWAP TMLHK WITH TELH05**

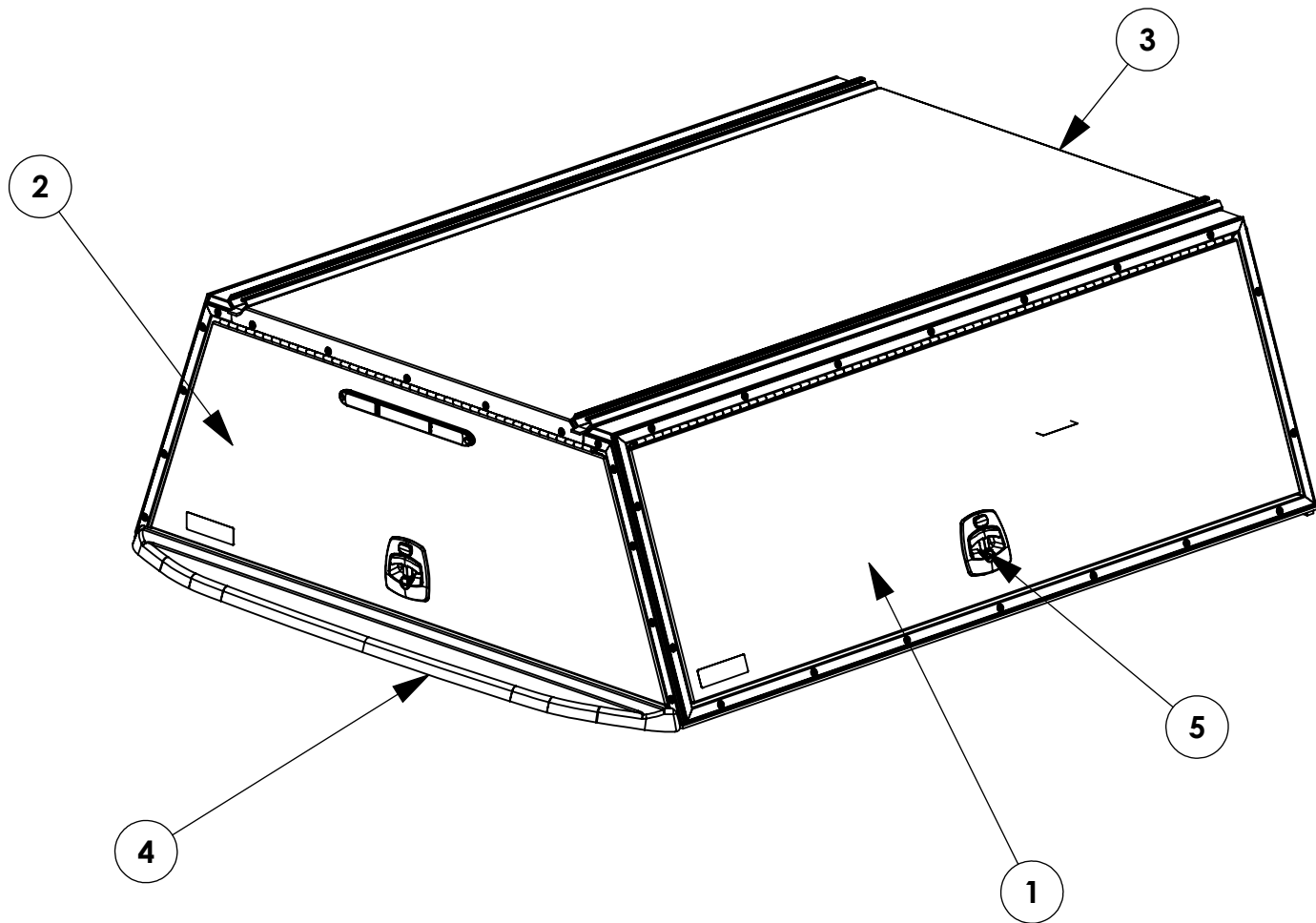

INSTR. NUMBER : **71622**

PG: **8** REV: **R**

PART NUMBER : **TFKNFT160HM23W**

PART DESC. : ASM INS, TFK\_\_T178HM23W

**BOM FOR 5.0' 23" TALL NISSAN FRONTIER**

ITEM NO.	PART NUMBER	DESCRIPTION	QTY.
1	TSK60M23W	TOP, SIDE KIT,60",M,23,W	2
2	TCK72HM23W	TOP,CLOSE KIT,72",HM23,W	1
3	TRK6023W	TOP, ROOF KIT,60",23,W	1
4	THKNFT172M23	HDW KIT, TFKNFT172HM23W	1
5	TMLHK	Topper Mechanical Lock Hatch Kit	1

**E-LOCK VERSIONS:**  
**SWAP M WITH E IN PART NUMBER**  
**EXAMPLE: TFKFDT178HM23W**  
**BECOMES TFKFDT178HE23W**

**\* E-LOCK VERSION SWAP TMLHK WITH TELH04**

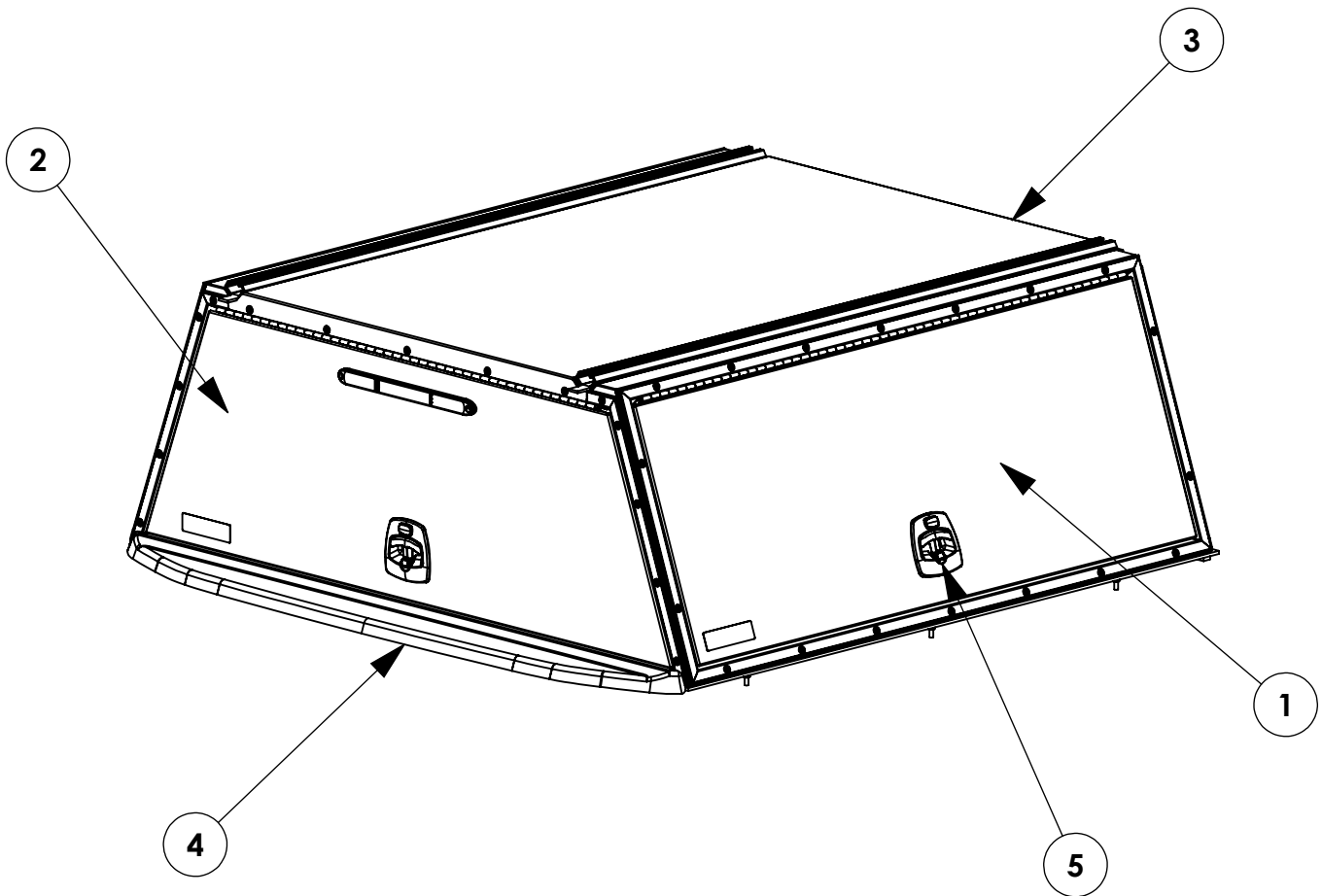

INSTR. NUMBER : <b>71622</b>		PG: <b>9</b>	REV: <b>R</b>	<b>BOM FOR 5.1' 23" TALL COLORADO</b>		
PART NUMBER : <b>TFKNFT160HM23W</b>		ITEM NO.	PART NUMBER	DESCRIPTION	QTY.	
PART DESC. : ASM INS, TFK__T178HM23W		1	TSKCOL60M23W	TOP, SIDE KIT,60",M,23,W	2	
		2	TCK72HM23W	TOP,CLOSE KIT,72",HM23,W	1	
		3	TRK6123W	TOP, ROOF KIT,61",23,W	1	
		4	THKCOL60M23	HDW KIT, TFKCOL160HM23W	1	
		5	TMLHK	Topper Mechanical Lock Hatch Kit	1	

**E-LOCK VERSIONS:**  
**SWAP M WITH E IN PART NUMBER**  
**EXAMPLE: TFKFDT178HM23W**  
**BECOMES TFKFDT178HE23W**

**\* E-LOCK VERSION SWAP TMLHK WITH TELH04**

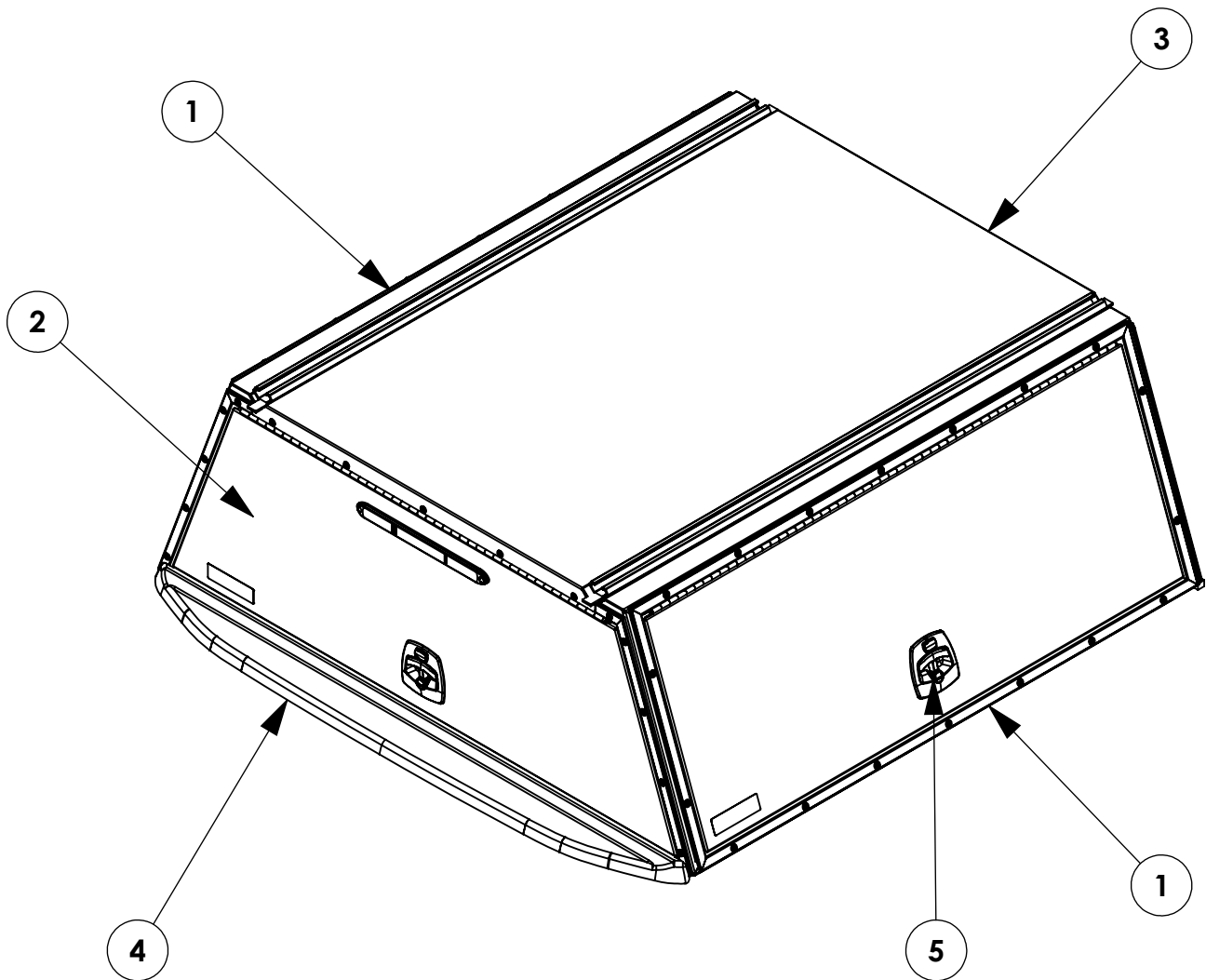

INSTR. NUMBER : <b>71622</b>		PG: <b>10</b>	REV: <b>R</b>	<b>BOM FOR 69" 23" TALL SILVERADO EV 1500</b>			
PART NUMBER : <b>TFKGME169HM23W</b>		ITEM NO.	PART NUMBER	DESCRIPTION	QTY.		
PART DESC. : ASM INS, TFKGME169HM23W		1	TSK69M23WPS	TOP, SIDE KIT,SILVERADO EV, 69", PS	1		
<b>E-LOCK VERSIONS:          SWAP M WITH E IN PART NUMBER          EXAMPLE: TFKFDT178HM23W          BECOMES TFKFDT178HE23W</b>		2	TSK69M23WDS	TOP, SIDE KIT,SILVERADO EV, 69",DS	1		
		3	TCKGMEHM23W	TOP,CLOSE KIT,SILVERADO EV, HM23,W	1		
		4	TRKGME6923W	TOP, ROOF KIT,69",23,W	1		
		5	THKGME169M23	HDW KIT, TFKGME169HM23W	1		
		6	TMLHK	Topper Mechanical Lock Hatch Kit	1		

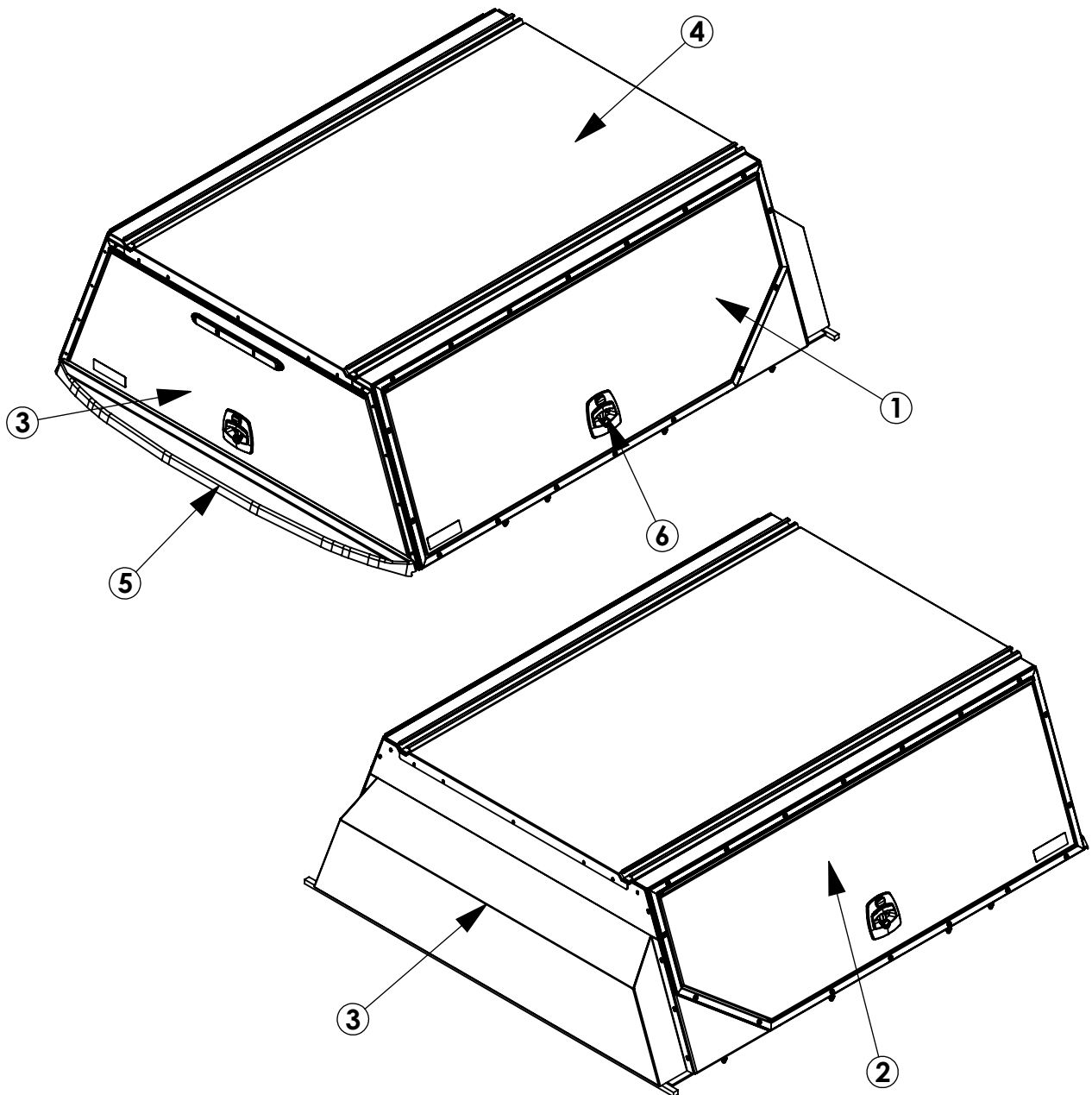

INSTR. NUMBER : 71622

PG: 11

REV: R

**BOM FOR 80" 23" TALL SILVERADO 2500, 3500**

PART NUMBER : TFKGMT280HM23W

PART DESC. : ASM INS, TFK\_\_T178HM23W

ITEM NO.	PART NUMBER	DESCRIPTION	QTY.
1	TSK80M23W	TOP, SIDE KIT,80",M,23,W	2
2	TCK78HM23W	TOP,CLOSE KIT,78",HM23,W	1
3	TRK8026W	TOP, ROOF KIT,80",26,W	1
4	THKGMT280M23	HDW KIT, TFKGMT280HM23W	1
5	TMLHK	Topper Mechanical Lock Hatch Kit	1

**E-LOCK VERSIONS:  
SWAP M WITH E IN PART NUMBER  
EXAMPLE: TFKFDT178HM23W  
BECOMES TFKFDT178HE23W**

**\* E-LOCK VERSION SWAP TMLHK WITH TELH03**

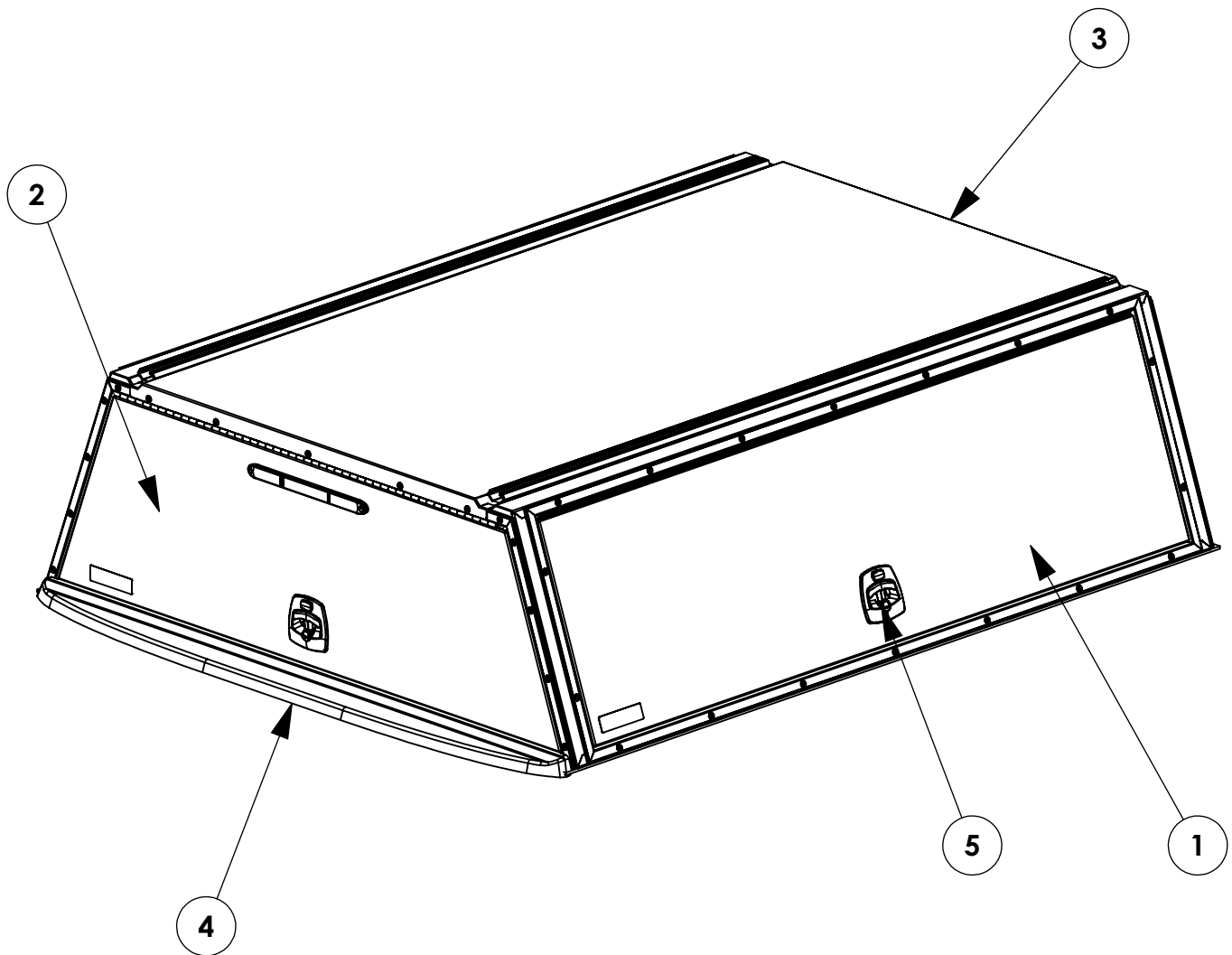

INSTR. : 71622  
NUMBER

PG: 12

REV: R

### BOM FOR 70" 23" TALL SILVERADO 1500

PART : TFKGMT170HM23W  
NUMBER

PART :  
DESC. : ASM INS, TFK\_\_T178HM23W

ITEM NO.	PART NUMBER	DESCRIPTION	QTY.
1	TSK70M23W	TOP, SIDE KIT,70",M,23,W	2
2	TCK78HM23W	TOP,CLOSE KIT,78",HM23,W	1
3	TRK7023W	TOP, ROOF KIT,70",23,W	1
4	THKGMT280M23	HDW KIT, TFKGMT280HM23W	1
5	TMLHK	Topper Mechanical Lock Hatch Kit	1

**E-LOCK VERSIONS:**  
SWAP M WITH E IN PART NUMBER  
EXAMPLE: TFKFDT178HM23W  
BECOMES TFKFDT178HE23W

**\* E-LOCK VERSION SWAP TMLHK WITH TELH03**

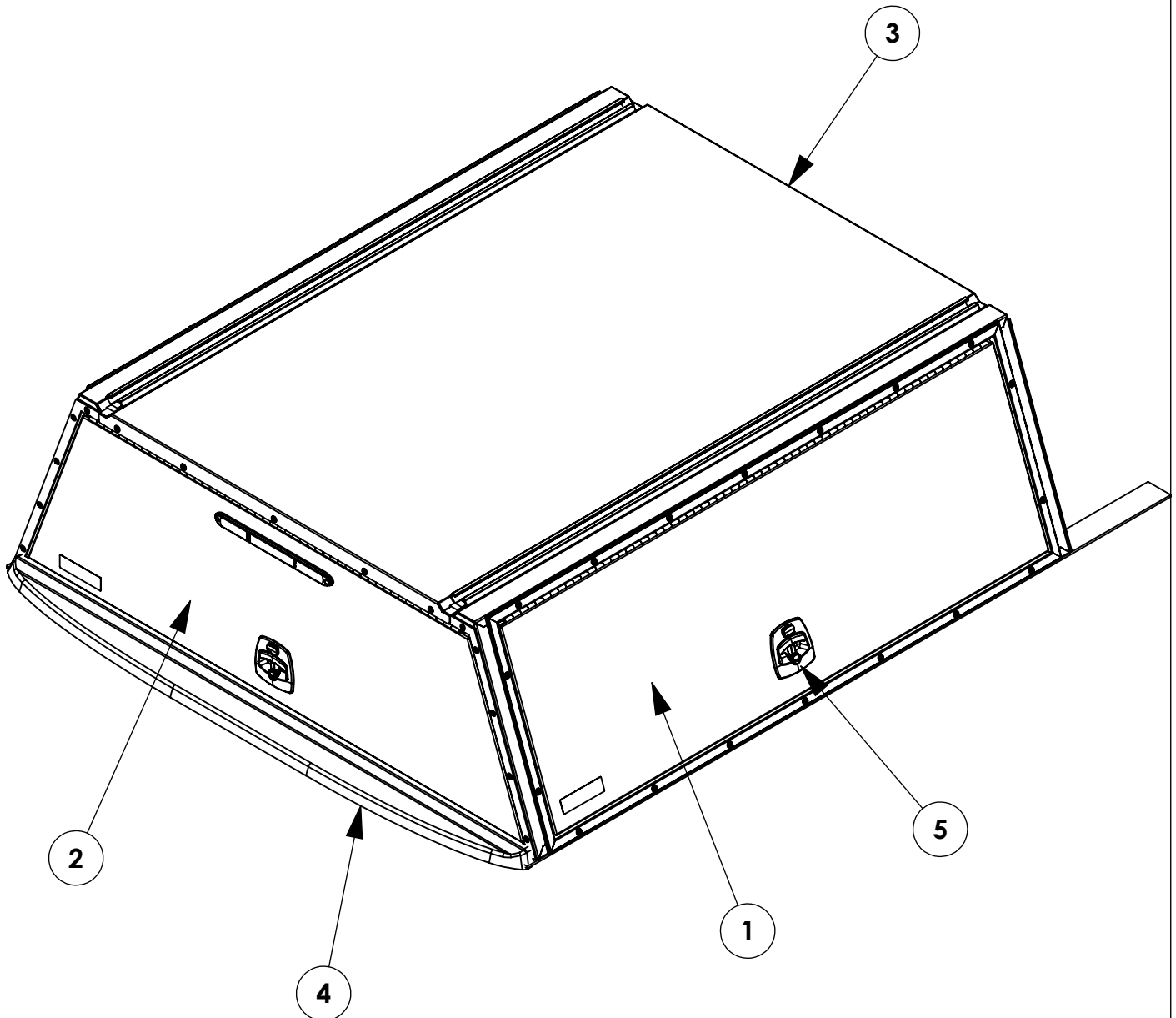

**GET TO KNOW THE VEHICLE** - AT THE BEGINNING OF ANY INSTALLATION, CHECK THE LOCATION OF THE FUEL TANK, FUEL LINES, BRAKE LINES, HIGH VOLTAGE BATTERIES AND WIRING HARNESSSES TO AVOID INJURY OR PROPERTY DAMAGE FROM TOOL CONTACT.

**SEAL ALL EXTERIOR HOLES** - ALL INSTALLATION HOLES SHOULD BE SEALED WITH BUTYL TAPE OR SILICON TO PREVENT WATER AND EXHAUST GASES FROM ENTERING THE VEHICLE.

**CONTROL DRILL DEPTH** - TO AVOID DAMAGE TO THE VEHICLE, USE A DRILL STOP OR CLEARED STEP BIT WHEN DRILLING INSTALLATION HOLES.

**ALWAYS ADD PRIMER** - WHEN ADDING INSTALLATION HOLES BE SURE TO USE A SELF-ETCHING PRIMER TO PREVENT CORROSION, FASTENER FAILURE AND INJURY.

**MOUNTING POINTS MUST HAVE METAL-TO-METAL CONTACT** - USE PROVIDED MOUNTING SPACERS TO ACCOMMODATE FOR VEHICLE FEATURES, CARPET OR SUBFLOORS.

**PROVIDE CLEARANCE FOR SPACERS** - IF THE INSTALLATION VEHICLE CONTAINS A CARPET OR SUBFLOOR, USE A 1-3/16" DIAMETER CARPET CUTTER (P/N: 31183-0) AT ALL MOUNTING LOCATIONS TO OPEN UP ROOM FOR SPACERS.

**CHECK SPACER ORIENTATION** - BE SURE THAT THE INDENT IN THE SPACER COVERS THE PLUSNUT HEAD; THIS ENSURES THE MOST METAL-TO-METAL CONTACT AND REDUCES VIBRATION.

**PLUSNUT INSTALLATION** - A PLUSNUT GUN IS RECOMMENDED FOR PLUSNUT INSTALLATION FOR ITS PRODUCTION SPEED. HOWEVER, A PLUSNUT SETTING TOOL CAN ALSO BE USED (P/N: 22200-0).

**THRU-BOLT CLEARANCE** - WHEN USING A THRU-BOLT AT ANY MOUNTING LOCATION, BE SURE THAT YOUR HOLE HAS 1/16" CLEARANCE.

**INTENTIONALLY LEFT BLANK**

**FASTENERS USED**

**BAG REFERENCE: ALL**

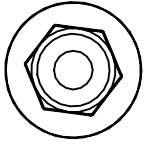

**FAS0055**  
**1/4-20 ZP**  
**HFLNG NLK NUT**  
**QTY: 19**

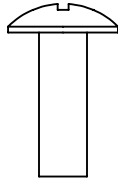

**FAS0062**  
**1/4-20 X 0.75 ZP**  
**THP SCREW**  
**QTY: 9**

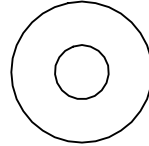

**FAS0067**  
**1/4 ZP**  
**FLAT WASHER**  
**QTY: 9**

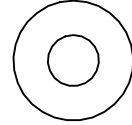

**FAS0234**  
**1/4 SST**  
**FLAT WASHER**  
**QTY: 30**

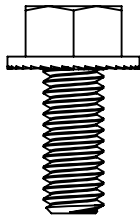

**FAS0438**  
**5/16-18 X .75 ZP**  
**HFLNG SCREW**  
**QTY: 16**

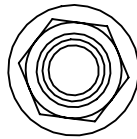

**FAS0440**  
**5/16-18 ZP**  
**HFLNG NLK NUT**  
**QTY: 16**

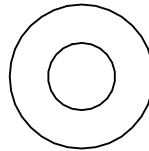

**FAS0552**  
**5/16 SST**  
**FLAT WASHER**  
**QTY: 10**

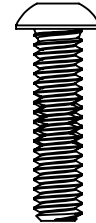

**FAS0920**  
**1/4-20 X 1.0 SST**  
**BHC SCREW**  
**QTY: 30**

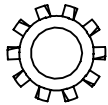

**FAS0066**  
**1/4 LOCK WASHER**  
**EXT. TOOTH**  
**QTY: 1**

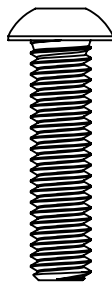

**FAS0919**  
**5/16-18 X 1.25 SST**  
**BHC SCREW**  
**QTY: 10**

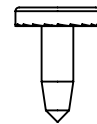

**FAS0148**  
**#10 X 0.5 NI-ZN**  
**PH SELF DRILL SCREW**  
**QTY: 1**

**INTENTIONALLY LEFT BLANK**

**FASTENERS USED**

**BAG REFERENCE: ALL**

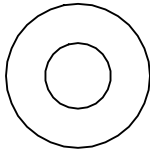

**FAS0164**  
**5/16 ALUM**  
**FLAT WASHER**  
**QTY BAG71794: 0**  
**QTY BAG71801: 8**

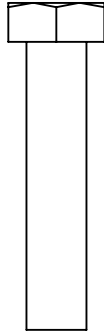

**FAS0242**  
**5/16-18 X 1.5 SST**  
**HH SCREW**  
**QTY BAG71794: 8**  
**QTY BAG71801: 8**

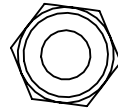

**FAS0248**  
**5/16-18 SST**  
**HH NLK NUT**  
**QTY BAG71794: 8**  
**QTY BAG71801: 8**

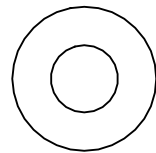

**FAS0552**  
**5/16 SST**  
**FLAT WASHER**  
**QTY BAG71794: 16**  
**QTY BAG71801: 8**

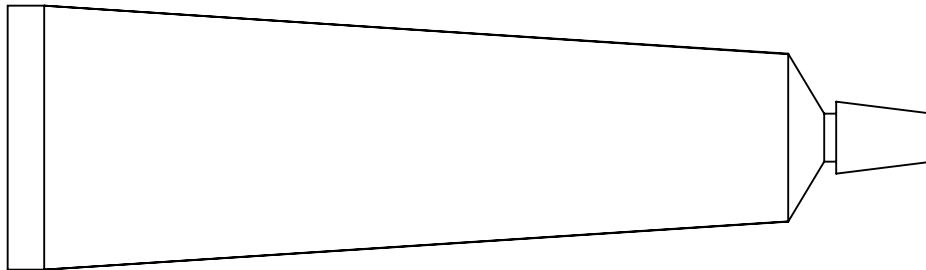

**26618-0**  
**1 OZ TUBE**  
**SILICONE**  
**QTY BAG71794: 2**  
**QTY BAG71801: 2**

**INTENTIONALLY LEFT BLANK**

PAGE:

**19**

**FASTENERS USED**

**BAG REFERENCE: BAG76637**



**FAS0917  
M5 X .8 ZP  
HFLNG NLK NUT  
QTY: 12**



**FAS0918  
10-24 ZP  
HFLNG NLK NUT  
QTY: 6**

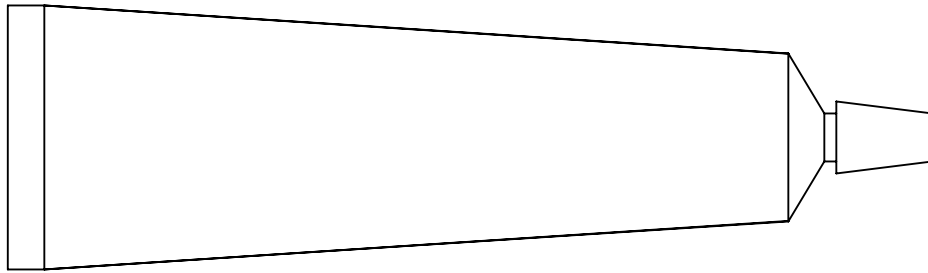

**26618-0  
1 OZ TUBE  
SILICONE**

**INTENTIONALLY LEFT BLANK**

**STEP 1 - ASSEMBLE BODY FRAME: SIDES AND CROSSBOWS**

**Step 1.1**  
**OPEN [x2]**  
**TOPPER SIDE**  
**KITS**  
**[TSK78M23W]**

**Step 1.2**  
**OPEN TOPPER**  
**ROOF KIT**  
**[TRK7823W]**

**Step 1.3**  
**FULLY TIGHTEN**  
**FAS0438 AND**  
**FAS0440**  
**(16 PLACES)**  
**1/2" WRENCH**  
**1/2" SOCKET**

**Step 1.4**  
**ADD FOAM**  
**STRIP 80402**  
**TO THE**  
**MIDDLE OF**  
**EACH**  
**CROSSBOW**  
**(4 PLACES)**

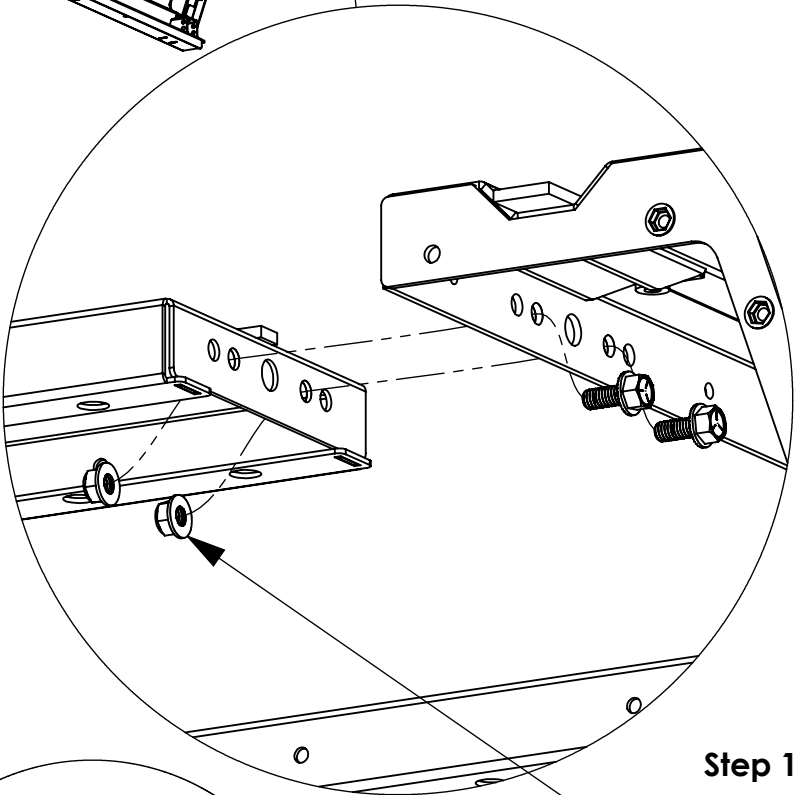
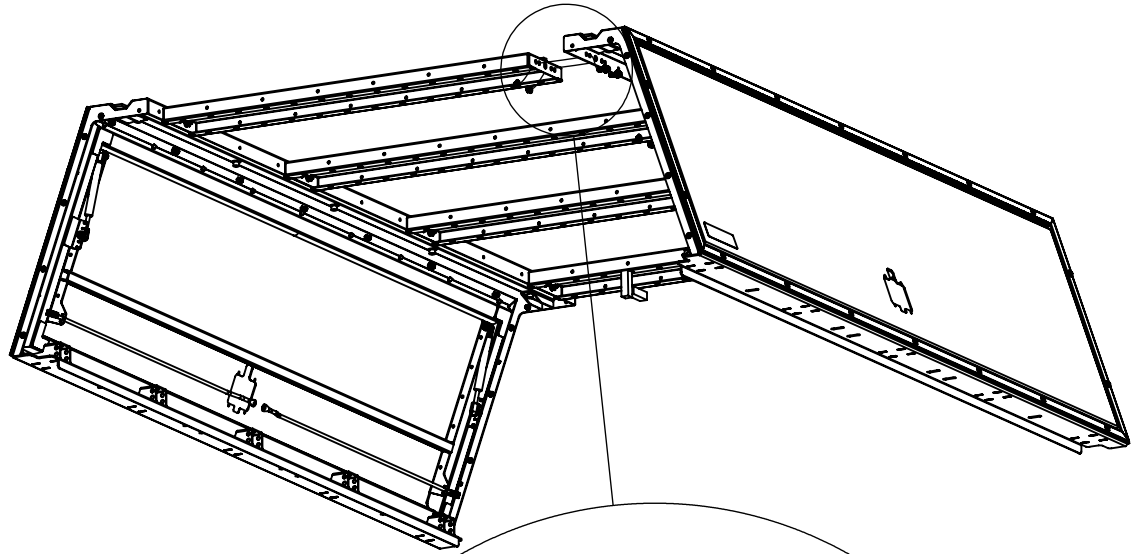

**Step 1.3**  
**NOTE: Nut**  
**inboard**

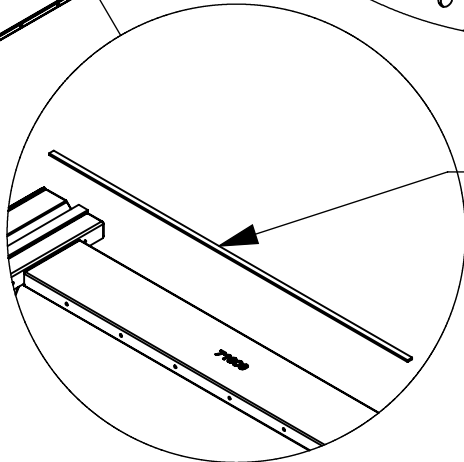
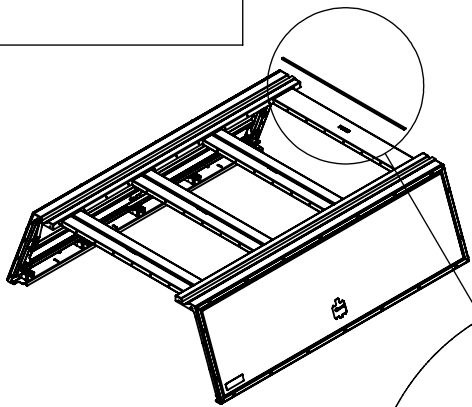

**Step 1.4**

**STEP 2 - ATTACH HARDWARE: SIDE DOOR HANDLES, FRONT & REAR SEALS**

**Step 2.1**  
CUT ZIP TIES  
THAT ARE  
HOLDING  
LOCKRODS IN  
PLACE.

**!! CAUTION !!**  
DOORS MAY  
TRY TO OPEN.

**Step 2.2**  
ATTACH HANDLE  
TO DOOR

**FULLY TIGHTEN**  
FAS0917  
(4 PER DOOR)  
M10 SOCKET

**DO NOT**  
OVERTIGHTEN

**Step 2.3**  
ATTACH  
LOCKRODS TO  
HANDLE

**FULLY TIGHTEN**  
FAS0918  
(2 PLACES)  
M8 SOCKET

**DO NOT**  
OVERTIGHTEN

**Step 2.4**  
ADJUST HANDLE  
POINT TO ALIGN  
WITH CASTING  
LINE ON HANDLE  
BODY  
(APPROX: 1.0")

**FULLY TIGHTEN**  
4mm ALLEN  
(2 PLACES)

**Step 2.5**  
APPLY FOAM  
SEALS TO ALL  
CORNERS.

**USE HOLES IN**  
SEAL TO ALIGN  
MATERIAL.

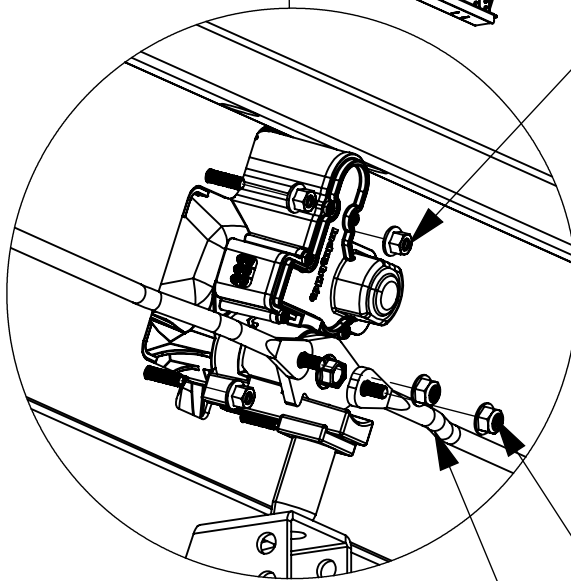
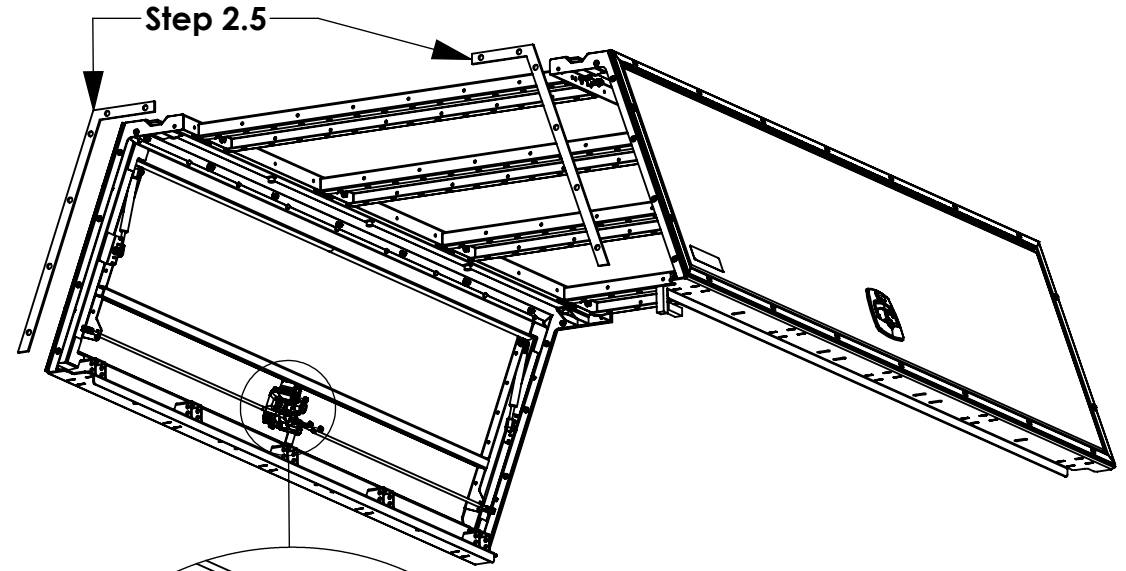

**Step 2.2**  
**STOP** STEP 2.2 & 2.3  
HAVE DIFFERENT  
SIZED FASTENERS

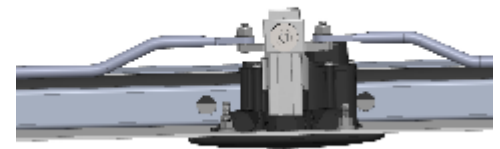

**Step 2.3**  
NOTE THAT ORIENTATION  
OF LOCKRODS IS CRITICAL **STOP**

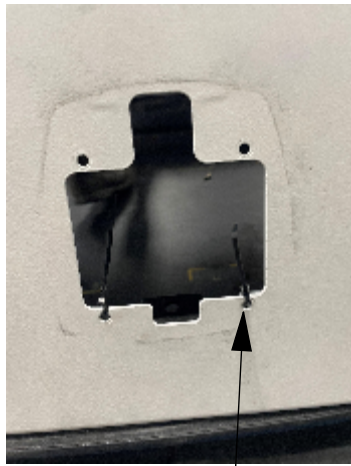

Step 2.1

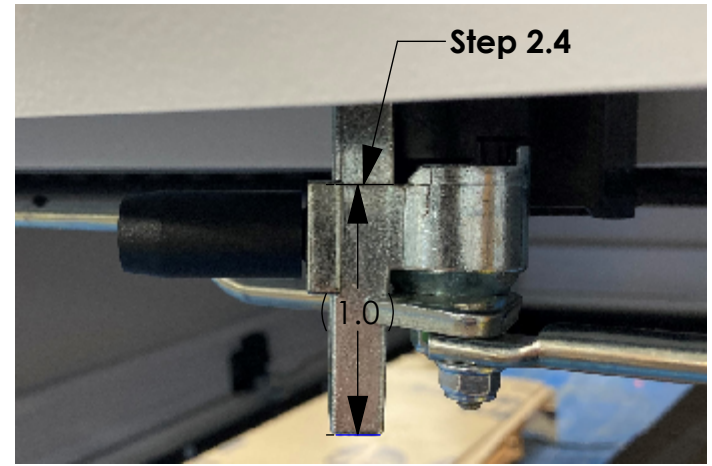

Step 2.4

**STEP 3 - ATTACH FRONT PANEL**

**Step 3.1  
OPEN TOPPER  
CLOSURE KIT  
[TCK78HM23W]**

**Step 3.2  
ATTACH FRONT  
PANEL**

**HAND TIGHTEN  
FAS0234,  
FAS0920  
(10 PLACES)**

**DO NOT  
TIGHTEN UNTIL  
AFTER STEP 4**

**Step 3.2B  
COLORADO  
FRONT PANEL  
FLANGE IS  
OUTBOARD**

**DO NOT  
TIGHTEN UNTIL  
AFTER STEP 4**

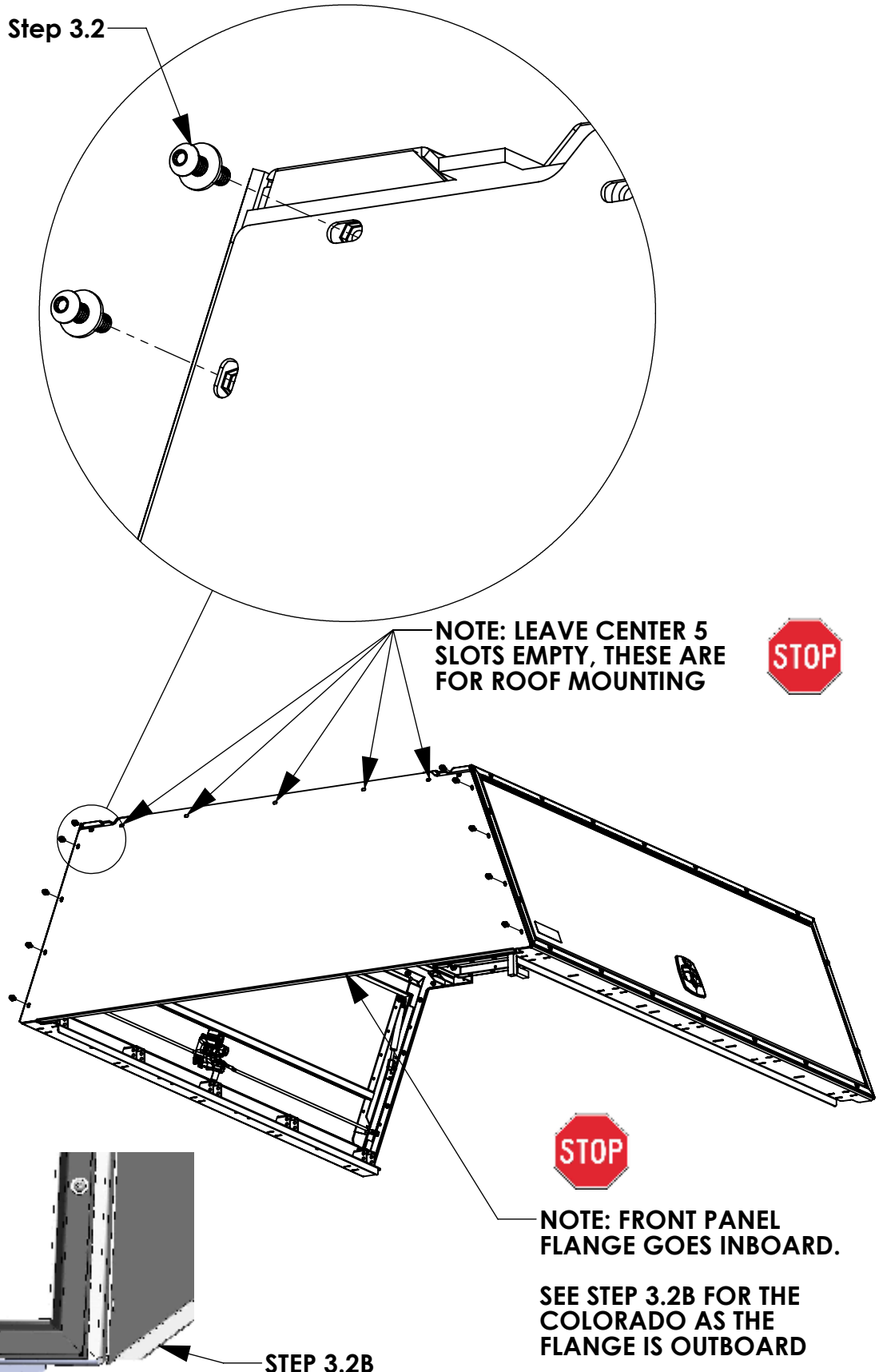

**NOTE: LEAVE CENTER 5 SLOTS EMPTY, THESE ARE FOR ROOF MOUNTING**



**NOTE: FRONT PANEL FLANGE GOES INBOARD.**

**SEE STEP 3.2B FOR THE COLORADO AS THE FLANGE IS OUTBOARD**

**STEP 3.2B**

**STEP 4 - ATTACH LIFTGATE**

**Step 4.1  
ATTACH  
LIFTGATE FRAME**

**FULLY TIGHTEN  
FAS0234,  
FAS0920  
(10 PLACES)  
5/32" ALLEN**

**Step 4.2  
GO BACK AND  
FULLY TIGHTEN  
FASTENERS  
FROM STEP 3.2**

**(10 PLACES)  
5/32" ALLEN**

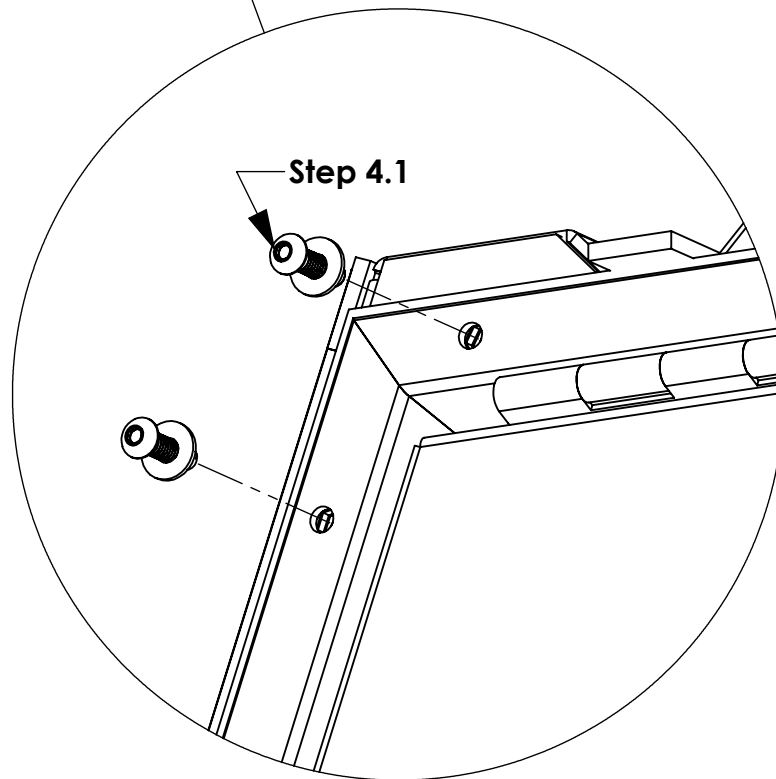
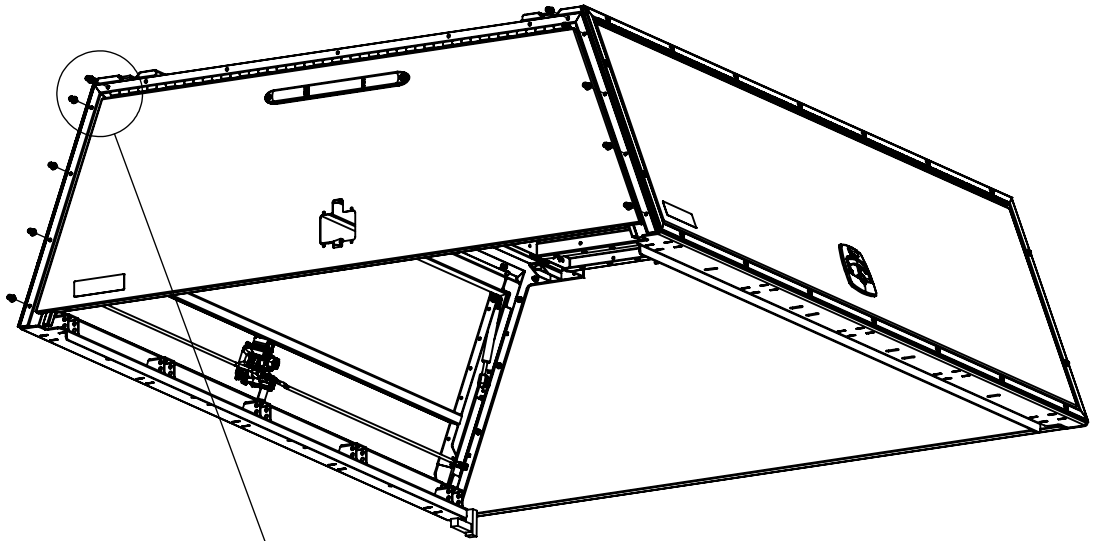

**STEP 5 - ATTACH LIFTGATE HANDLE**

**Step 5.1**  
CUT ZIP TIES  
THAT ARE  
HOLDING  
LOCKRODS IN  
PLACE.

**!! CAUTION !!**  
DOOR MAY TRY  
TO OPEN.

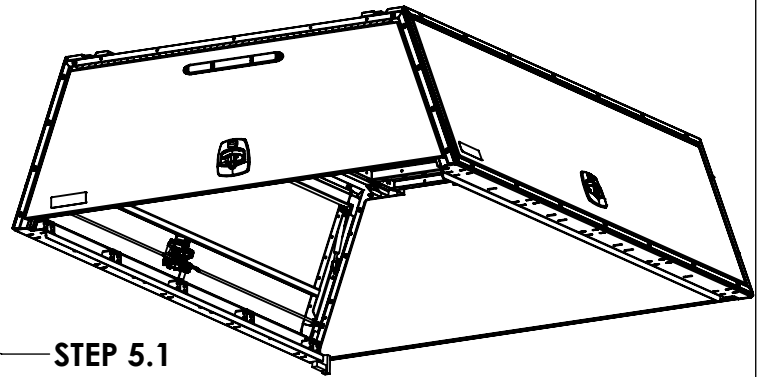
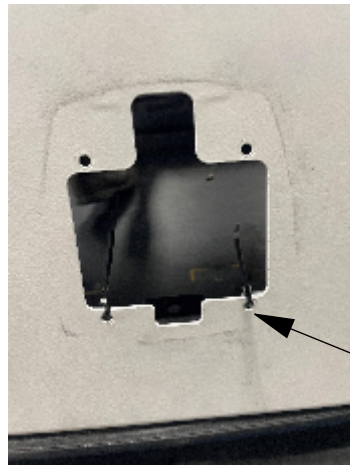

**Step 5.2**  
ATTACH HANDLE  
TO DOOR

**FULLY TIGHTEN**  
FAS0917  
(4 PER DOOR)  
M10 SOCKET

**DO NOT**  
OVERTIGHTEN

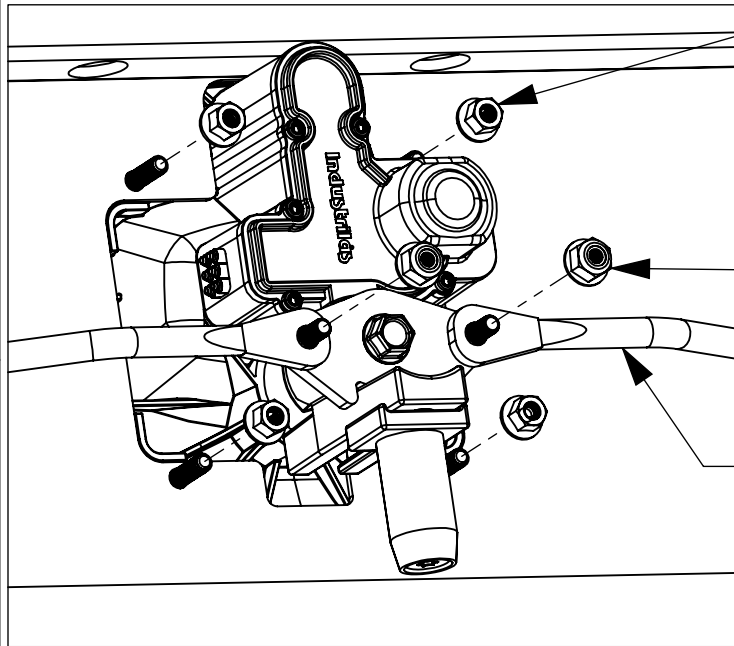

STEP 5.2



STEP 5.2 & 5.3  
HAVE DIFFERENT  
SIZED FASTENERS

STEP 5.3

NOTE THAT ORIENTATION  
OF LOCKRODS IS  
CRITICAL



**Step 5.3**  
ATTACH  
LOCKRODS TO  
HANDLE

**FULLY TIGHTEN**  
FAS0918  
(2 PLACES)  
M8 SOCKET

**DO NOT**  
OVERTIGHTEN

**Step 5.4**  
ADJUST HANDLE  
POINT TO ALIGN  
WITH CASTING  
LINE ON HANDLE  
BODY  
(APPROX: 1.0")

**FULLY TIGHTEN**  
M4 ALLEN  
(2 PLACES)

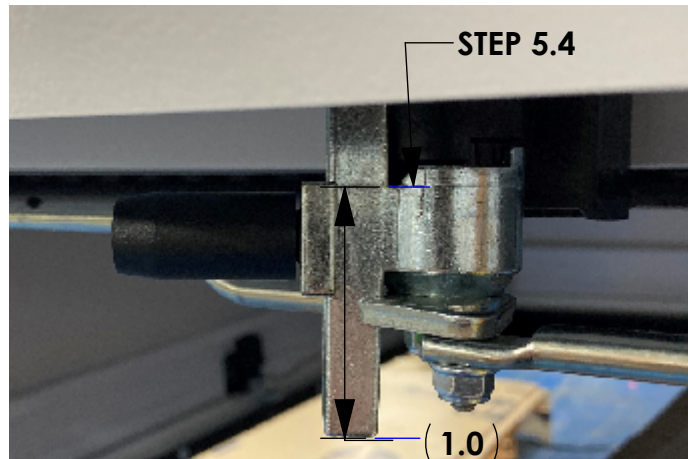

**STEP 6 - ATTACH ROOF AND ROOF RAILS**

**Step 6.1**  
**SET ROOF PANEL**  
**ON TOPPER BODY**



**PLEASE NOTE THAT ORDER OF OPERATIONS ON THESE BUILD STEPS IS CRITICAL TO A PROPER SEAL!**

**Step 6.2**  
**ATTACH**  
**MOUNTING RAILS**  
**TO TOPPER BODY.**

**USE AN**  
**ALIGNMENT**  
**PUNCH TO POKE**  
**THROUGH SEALS**

**FULLY TIGHTEN**  
**FAS0552,**  
**FAS0919**  
**(10 PLACES)**  
**3/16" ALLEN**

**Step 6.3**  
**ATTACH ROOF**  
**TO TOPPER**  
**BODY.**

**FULLY TIGHTEN**  
**FAS0055,**  
**FAS0552,**  
**FAS0920**  
**(10 PLACES)**  
**5/32" ALLEN**  
**7/16" WRENCH**

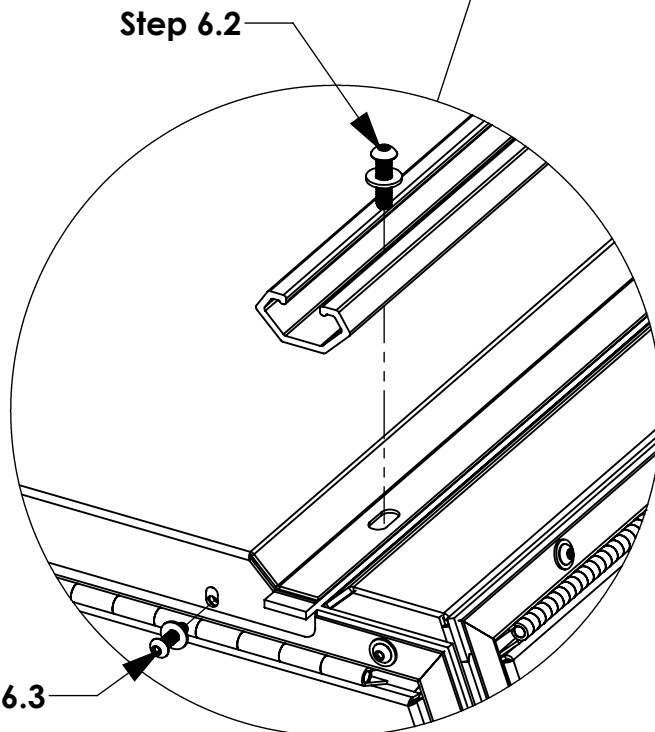
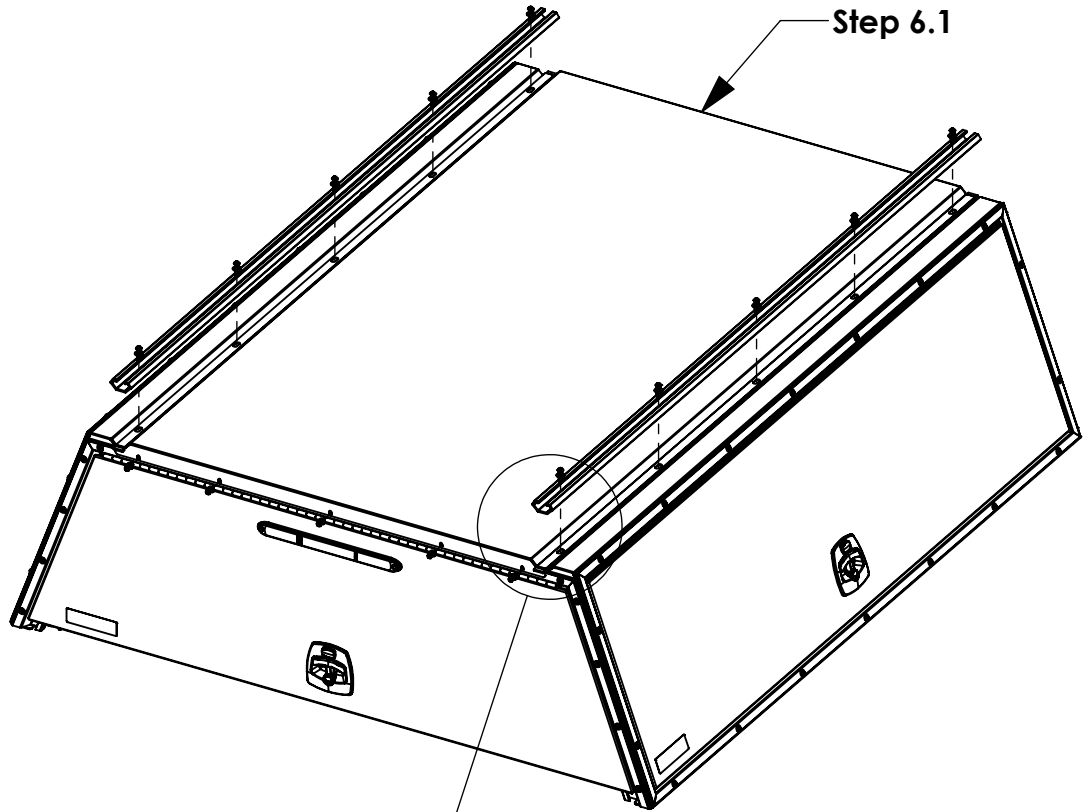

**STEP 7 - ATTACH TAILGATE COVER**

**Step 7.1**  
**ADD SILICONE TO**  
**CORNER OF**  
**TAILGATE COVER**  
**AND AROUND**  
**BOTTOM FACE**  
**MOUNTING**  
**HOLES.**

**Step 7.1**  
**FULL LENGTH**  
**OF THIS SEAM**

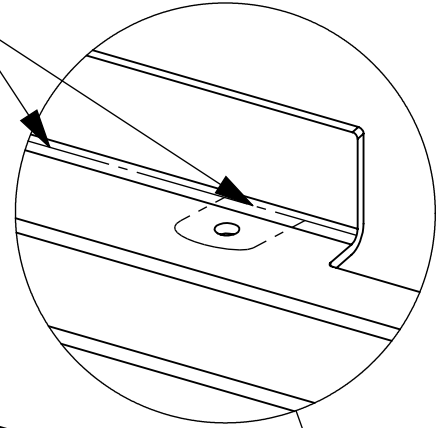

**Step 7.2**  
**ATTACH TAILGATE**  
**COVER TO REAR**  
**DOOR.**

**NOTE: INSTALL**  
**CENTER BOLT FIRST**  
**TO HOLD IN PLACE**  
**DURING INSTALL**

**FULLY TIGHTEN**  
**FAS0062,**  
**FAS0067,**  
**FAS0055**  
**(9 PLACES)**

**#2 PHILLIPS**  
**7/16" SOCKET**  
**7/16" WRENCH**

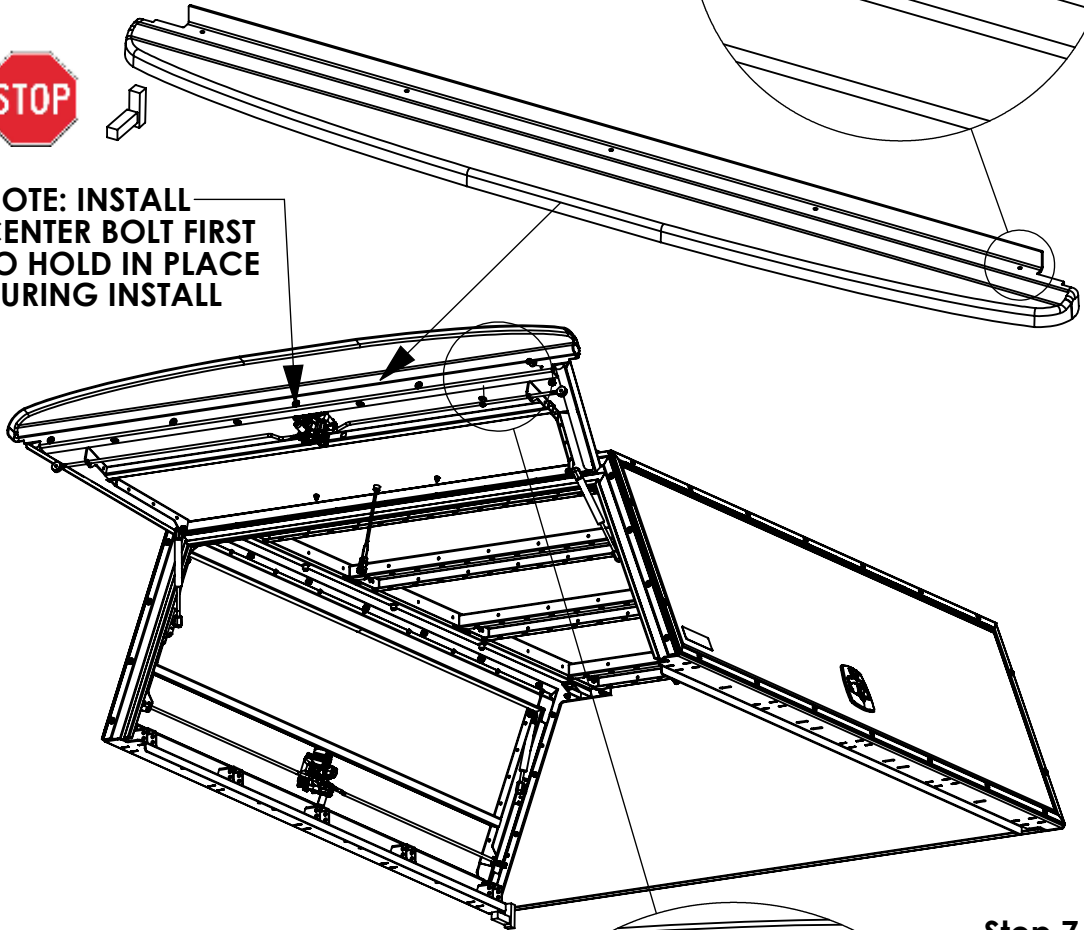

**Step 7.2**

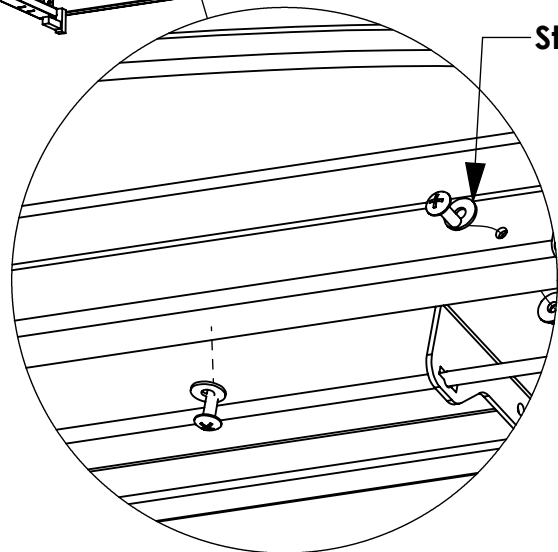

**STEP 7 - ATTACH TAILGATE COVER CONT'D (NOTE: FOR COLORADO AND SILVERADO ONLY)**

**Step 7.3  
COLORADO &  
SILVERADO.  
PREP WITH 57392  
ADHESION  
PROMOTER.**

**ADD 77152  
D-SEAL X 22" LG  
TO BOTH SIDE OF  
TAILGATE COVER**



**Step 7.3  
COLORADO &  
SILVERADO**

**Step 7.4  
SILVERADO.  
PREP WITH 57392  
ADHESION  
PROMOTER.**

**APPLY 73398  
TAILGATE FOAM  
AS SHOWN ON  
BOTH SIDES OF  
INSIDE OF  
TAILGATE COVER.  
USE A ROLLER  
AND APPLY 15 PSI  
OVER SEAL FOR  
PROPER  
ADHESION.**



**Step 7.4**

**Step 7.5  
SILVERADO.  
PREP WITH 57392  
ADHESION  
PROMOTER.**

**CUT (3) PIECES  
AND APPLY 73398  
TAILGATE FOAM  
AS SHOWN ON  
BOTH ENDS OF  
TOPPER. USE A  
ROLLER AND  
APPLY 15 PSI  
OVER SEAL FOR  
PROPER  
ADHESION.**

**Step 7.5  
COLORADO &  
SILVERADO**

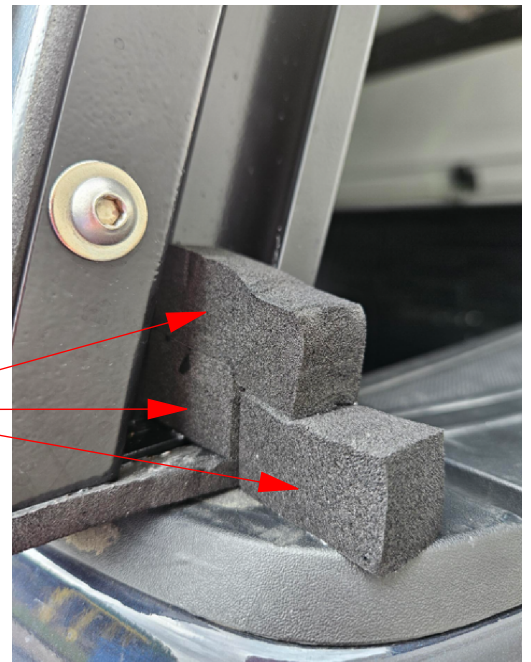

**STEP 8 - ATTACH SEALS TO TRUCK BED**

**Step 8.1**  
**INSTALL FRONT**  
**BED SEAL. REFER**  
**TO TABLE 1 TO**  
**GET OEM**  
**SPECIFIC**  
**DISTANCE OFF**  
**OF THE INSIDE**  
**EDGE OF THE**  
**BED. CENTER**  
**BETWEEN THE**  
**DRIVER AND**  
**PASSENGER SIDE**  
**BED RAIL TRIM.**

**TRIM OFF EXTRA,**  
**IF NECESSARY.**

**Step 8.2**  
**INSTALL SIDE BED**  
**SEALS. ALIGN TO**  
**THE FRONT AND**  
**INSIDE EDGES OF**  
**THE SIDE BED**  
**RAIL TRIM.**

**DO NOT TRIM**  
**EXCESS UNTIL**  
**TOPPER IS ON**  
**THE TRUCK.**

**Step 8.3**  
**COLORADO**  
**ONLY !**  
**INSTALL SIDE BED**  
**SEALS. ALIGN TO**  
**THE FRONT AND**  
**INSIDE EDGES OF**  
**THE SIDE BED**  
**RAIL TRIM.**

**DO NOT TRIM**  
**EXCESS UNTIL**  
**TOPPER IS ON**  
**THE TRUCK.**

**TOP VIEW -COLORADO, SILVERADO**  
**& RAM, FULL DISTANCE AT FRONT**  
**EDGE**

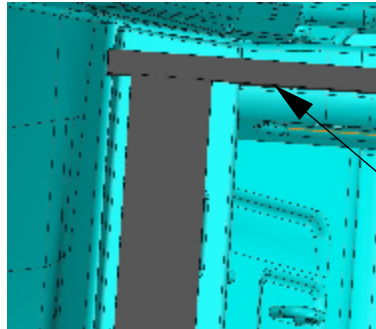

**STEP 8.3**  
**AT FLAT**

**Step 8.1**  
**DIST**

**STEP 8.3**  
**1/4" GAP**

**TOP VIEW**

**Step 8.2**

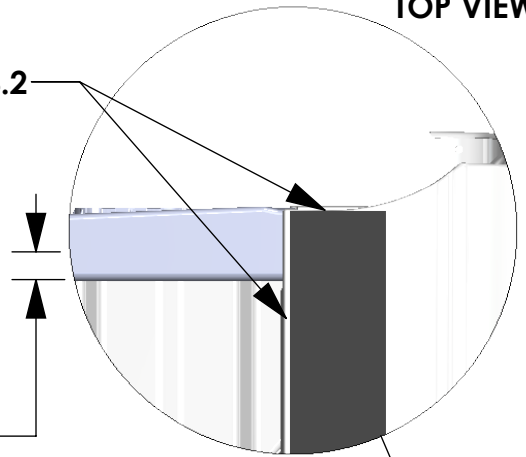

**FRONT**

**DRIVER'S**  
**SIDE**



**TABLE 1:**

VEHICLE PLATFORM	DIST.
F-150	.875"
SILVERADO	0.25"
RAM	.15"

# STEP 8 - ATTACH SEALS TO TRUCK BED (NOTE: FOR CHEVY SILVERADO ONLY)

**Step 8.4**  
**PLACE 81456 GASKET IN THE GAP BETWEEN THE TRUCK BED AND CAB.**



**BEFORE ATTACHING TO TRUCK BED, CLEAN AND PREP AREA. DO NOT ATTACH TO PLASTIC TRIM. IF TRIM IS ON FRONT OF BED ATTACH TO CAB.**

**ONCE AREA IS PREPARED CENTER GASKET ON THE REAR WINDOW.**

**MAKE SURE THAT GASKET HAS FULL SURFACE CONTACT SO ADHESIVE WILL PROPERLY BOND.**

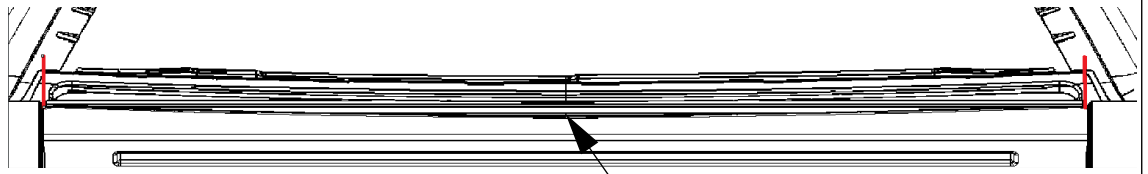

Step 8.4

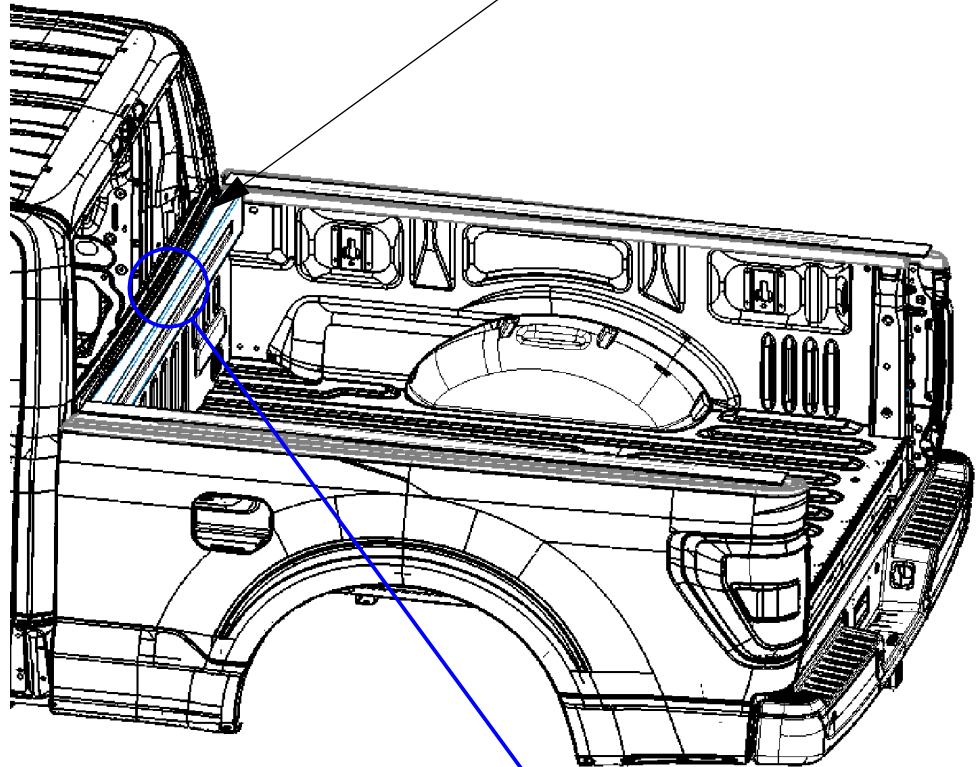

**NOTE:**  
**IF TRUCK BED HAS A SPRAY ON BED LINER, PLACE GASKET UNDER LINER ON TRUCK BED**

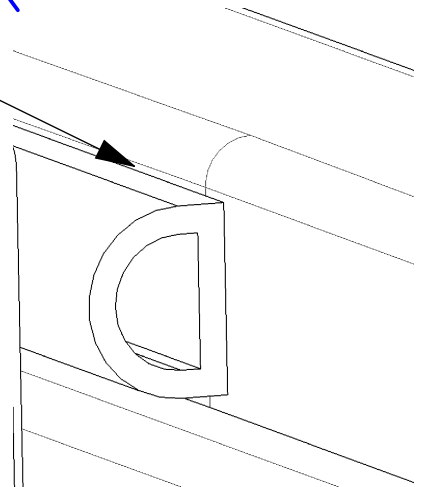

# STEP 9A - INSTALL FOAM & 73740 SEALANT TO TRUCK CAB AND BED SEAMS (NOTE: FOR CHEVY SILVERADO ONLY)

**STEP 9A.1**  
CUT A 2.5" FOAM PIECE OF 73398, INSERT UNDER TRIM OF THE BED RAIL, GOING INTO THE GAP AS SHOWN

**STEP 9A.1**

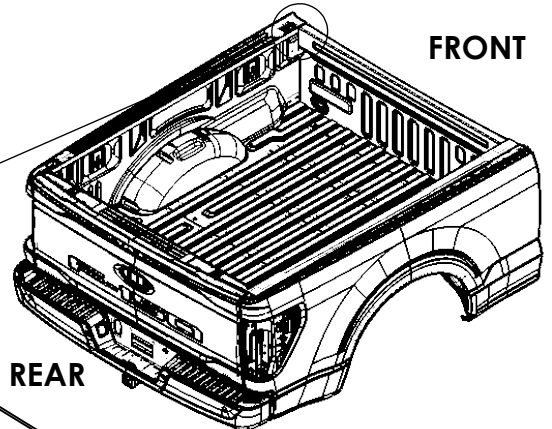

THERE IS A GAP BETWEEN THE OEM BED AND TRIM (NOT SHOWN)

INSERT THE FOAM UNDER THE TRIM AND COVER THE GAP W/ THE FOAM

**STEP 9A.2**  
INSERT A 2ND FOAM OF THE SAME DIMENSION INTO THE GAP, PERPENDICULAR TO THE ONE IN STEP 9.1. BOTH PIECES SHOULD BE TOUCHING

**STEP 9A.3**  
SECURE BOTH PIECES OF FOAM IN PLACE WITH 3M SEALANT AROUND THE PERIMETER AND FILL ANY REMAINING GAPS, REPEAT ON PASSENGER SIDE

**STEP 9A.2**

INSERT THE 2ND PIECE OF FOAM PERPENDICULAR TO THE 1ST PIECE. FOLD OVER THE FOAM TO ALSO COVER THE GAP BETWEEN THE TRIM AND WALL RAIL

**STEP 9A.3**

ADD 3M SEALANT AROUND THE PERIMETER OF THE FOAMS, BETWEEN THE RAIL TRIM & THE BED, & REPEAT ON PASSENGER SIDE

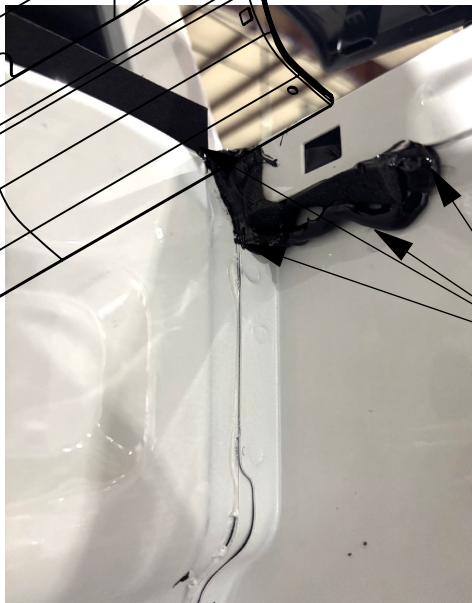

# STEP 9B - INSTALL FOAM TO TRUCK CAB AND BED SEAMS (NOTE: FOR CHEVY SILVERADO EV ONLY)

**STEP 9B.1**  
PLACE FOAM  
AROUND TOP  
OF BED RAILS,  
STRIPS WILL  
BUTT UP  
AGAINST EACH  
OTHER AT  
CORNERS

STEP 9B.1

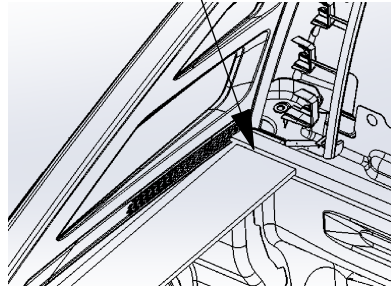

**STEP 9B.2**  
WHEN PLACING  
TOPPER ON BED,  
TOPPER WILL  
NEED TO BE  
BROUGHT IN  
LOW AND THEN  
MOVED  
FORWARD TO FIT  
INSIDE TRUCK  
TRIM. (AS  
SHOWN)

**NOTE:**  
LOCATE DRAIN HOLES AND  
TRIM FOAM AROUND THEM,  
TO MAKE SURE HOLES AREN'T  
BEING BLOCKED

71768

71766

FRONT

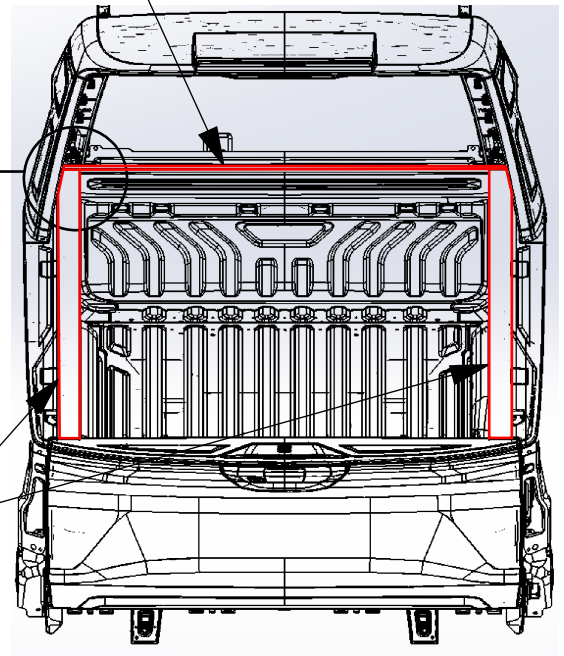

REAR

**STEP 9B.3**  
WITH TOPPER IN  
PLACE EXCESS  
TRIM

STEP 9B.2

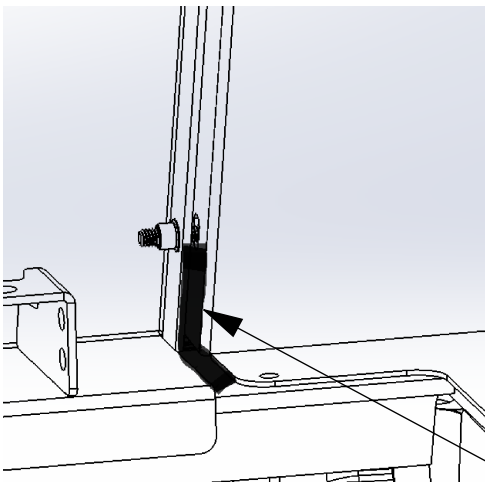
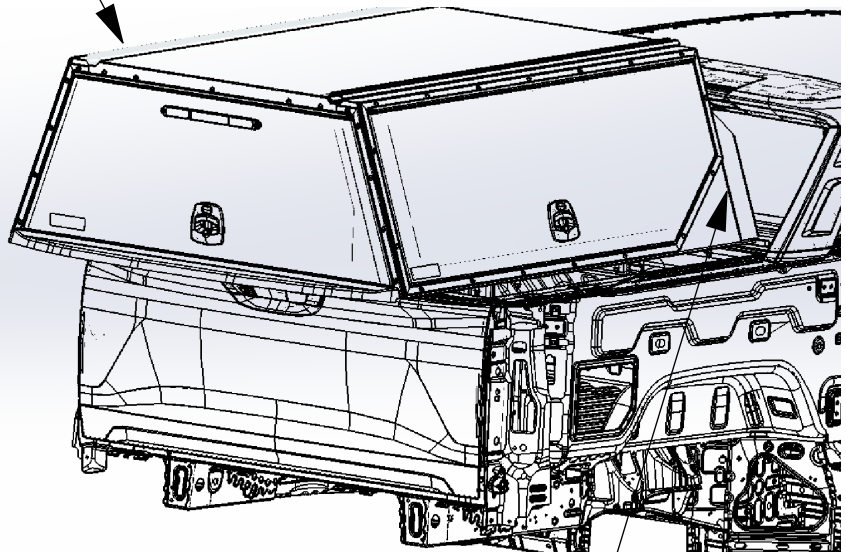

**NOTE:**  
WHEN TOPPER IS IN PLACE USE  
SLICONE INSIDE OF TOPPER TO  
SEAL GAPS AT FRONT OF TOPPER .  
(AS SHOWN)

# STEP 9C - INSTALL FOAM, (6) SPACER & 73740 SEALANT TO TRUCK CAB AND BED SEAMS (NOTE: FOR FORD RANGER ONLY)

STEP 9C.1  
REMOVE PLUGS  
LOCATED ON  
THE TRUCK BED  
RAIL,



DO NOT DRILL  
INTO THE RAIL

STEP 9C.2  
CENTER  
(6) SPACERS  
OVER HOLE,  
TAPE SPACER TO  
HOLD IT IN THE  
LOCATION

NOTE:  
TALL SPACERS  
TO BE USED  
WITH 2025  
MODELS,

SHORT SPACERS  
TO BUT USED  
WITH 2026 OR  
NEWER MODELS

STEP 9C.3  
PLACE FOAM  
AROUND TOP OF  
BED RAILS, STRIPS  
WILL BUTT UP  
AGAINST EACH  
OTHER AT  
CORNERS

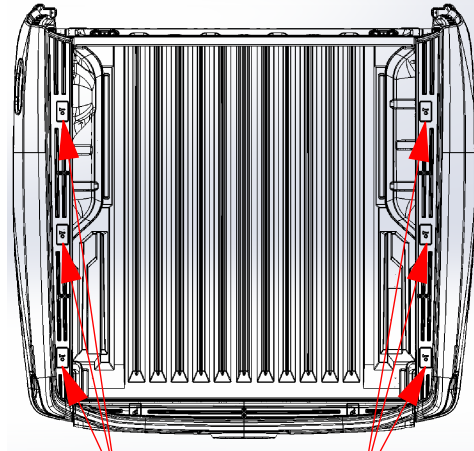

STEP 9C.1

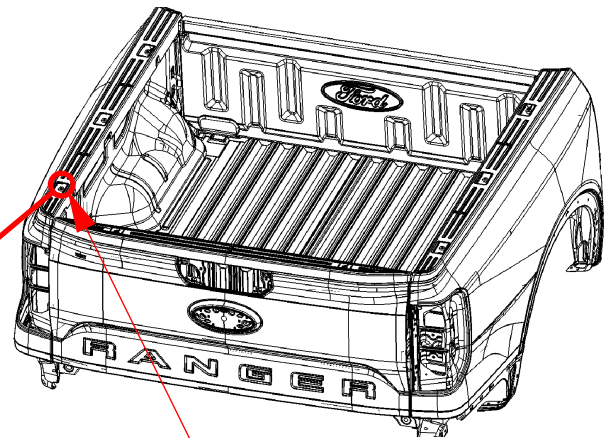
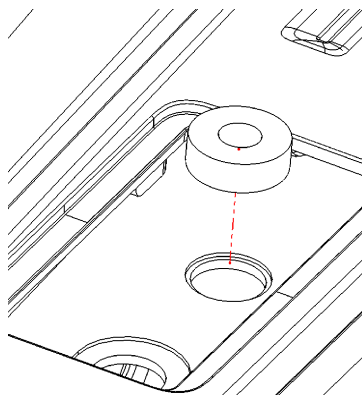

STEP 9C.2

STEP 9C.3

71766

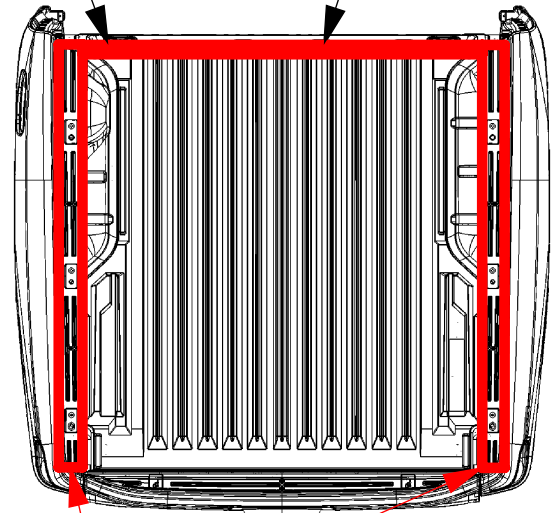

71768



NOTE:  
BEFORE INSTALL PREP IS STARTED,  
IF RANGER MODEL YEAR IS 2024, MAKE SURE  
THAT LOAD BOX REINFORCEMENT BRACKETS  
HAVE BEEN INSTALLED. SCAN QR CODE FOR  
DOCUMENTED DIRECTION



# STEP 9C - INSTALL FOAM, (6) SPACER & 73740 SEALANT TO TRUCK CAB AND BED SEAMS (NOTE: FOR FORD RANGER ONLY)

**STEP 9C.4**  
SLIDE 80670 & 80671 UNDER TRIM AT FRONT CORNERS OF BED TO MOUNT TO OEM HOLES, FULLY TIGHTEN (6)FAS0329, (6)FAS0552, & (6)FAS0588

**M8 SOCKET DRILL**

**NOTE:**  
TRIM IS NOT VISIBLE FOR CLARITY

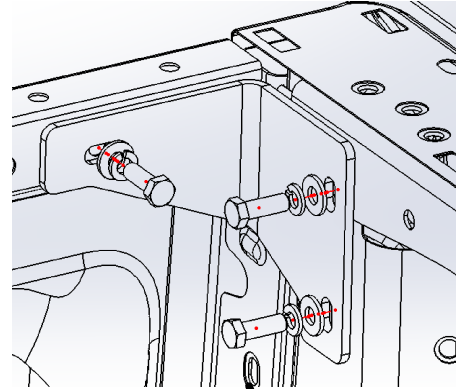

STEP 9C.4

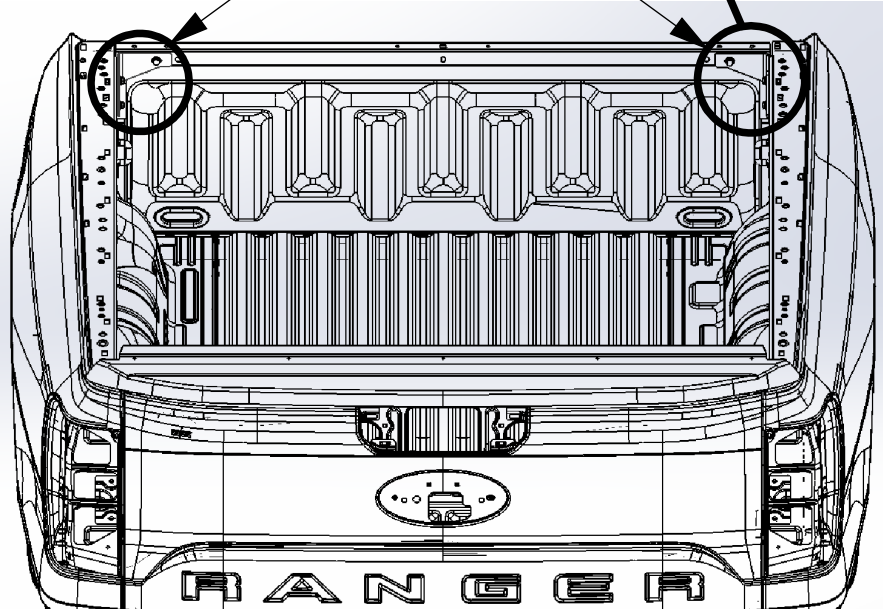

**NOTE:**  
BEFORE INSTALL PREP IS STARTED, IF RANGER MODEL YEAR IS 2024, MAKE SURE THAT LOAD BOX REINFORCEMENT BRACKETS HAVE BEEN INSTALLED. SCAN QR CODE FOR DOCUMENTED DIRECTION



**STEP 10 - ATTACH TOPPER TO TRUCK BED**



**NOTE: (FOR 8.0' 26" TALL RAM 1500, 2500, 3500 ONLY) TOPPER MUST BE SOFT INSTALLED TO MARK FOR DRILLING. TOPPER TO BE REMOVED PRIOR TO DRILLING.**

**Step 10.1  
SET TOPPER ONTO TRUCK BED.  
ALIGNMENT IS BASED OFF OF THE TAILGATE CLEARANCE CUTOUT IN THE SIDE BED RAILS (FOR FORD ONLY) AND PLACE ON THE PREVIOUSLY INSTALLED FRONT BED SEAL STEP 8.1**

**THESE 2 FACES SHOULD BE ALIGNED.**

**Step 10.2  
USE HOLES IN THE BED RAIL TO MARK AND DRILL MOUNTING LOCATIONS. IT IS NOT NECESSARY TO REMOVE THE TOPPER FOR THIS STEP.**

**(8 PLACES)  
1 1/32" DRILL BIT**



**NOTE: IF THESE HOLES INTERFERE WITH THE OEM BODY, DRILL A NEW HOLE IN THE BED RAIL +/- 2" FROM THE INTERFERENCE.**

**NOTE: IT IS RECOMMENDED THAT YOU LOAD THE TOPPER ONTO A TRUCKBED WITH ONE OF THE FOLLOWING METHODS:**

- HOIST: ATTACH TO THE ROOF RAILS OF THE TOPPER
- FORKLIFT: OPEN THE REAR DOOR AND SET FORKS ON THE ROOF BOWS
- MANUAL: HAVE 1 INDIVIDUAL AT EACH CORNER OF THE TOP AND CARRY OVER THE SIDES OF THE TRUCK. DO NOT SCRATCH THE VEHICLE.

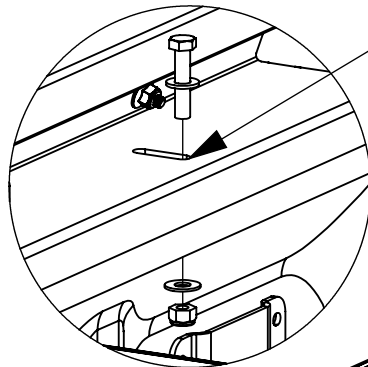

Step 10.2

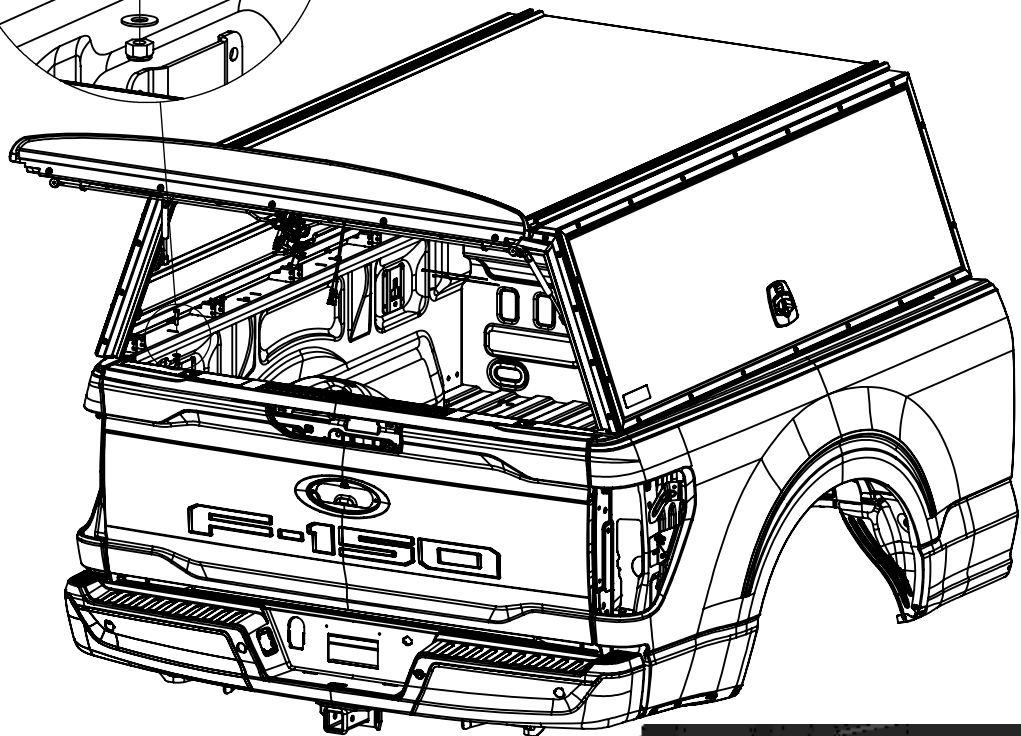

Step 10.1

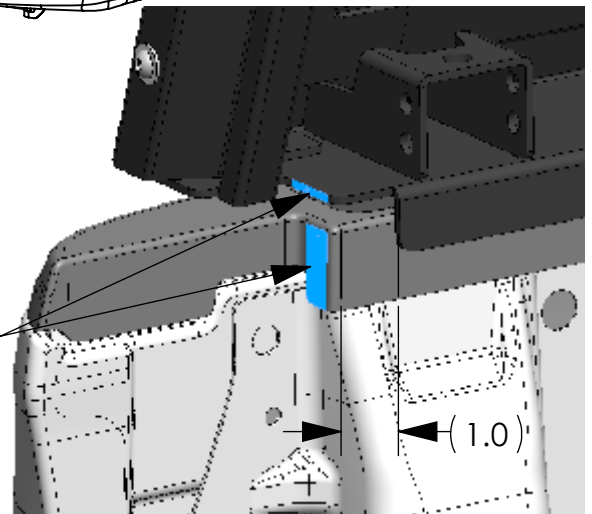

### STEP 10 ALT- ATTACH TOPPER TO TRUCK BED



NOTE: (FOR 5.0' FORD RANGER ONLY) TOPPER MUST BE SOFT INSTALLED TO MARK FOR DRILLING. TOPPER TO BE REMOVED PRIOR TO DRILLING.

Step 10.1 ALT  
SET TOPPER ONTO  
TRUCK BED.  
ALIGNMENT IS  
BASED OFF OF  
THE TAILGATE  
CLEARANCE  
CUTOUT IN THE  
SIDE BED RAILS  
(FOR FORD ONLY)  
AND PLACE ON  
THE PREVIOUSLY  
INSTALLED FRONT  
BED SEAL STEP 8.1

THESE 2 FACES  
SHOULD BE  
ALIGNED.

NOTE: IT IS RECOMMENDED THAT YOU LOAD THE TOPPER ONTO A TRUCKBED WITH ONE OF THE FOLLOWING METHODS:

- HOIST: ATTACH TO THE ROOF RAILS OF THE TOPPER
- FORKLIFT: OPEN THE REAR DOOR AND SET FORKS ON THE ROOF BOWS
- MANUAL: HAVE 1 INDIVIDUAL AT EACH CORNER OF THE TOP AND CARRY OVER THE SIDES OF THE TRUCK. DO NOT SCRATCH THE VEHICLE.

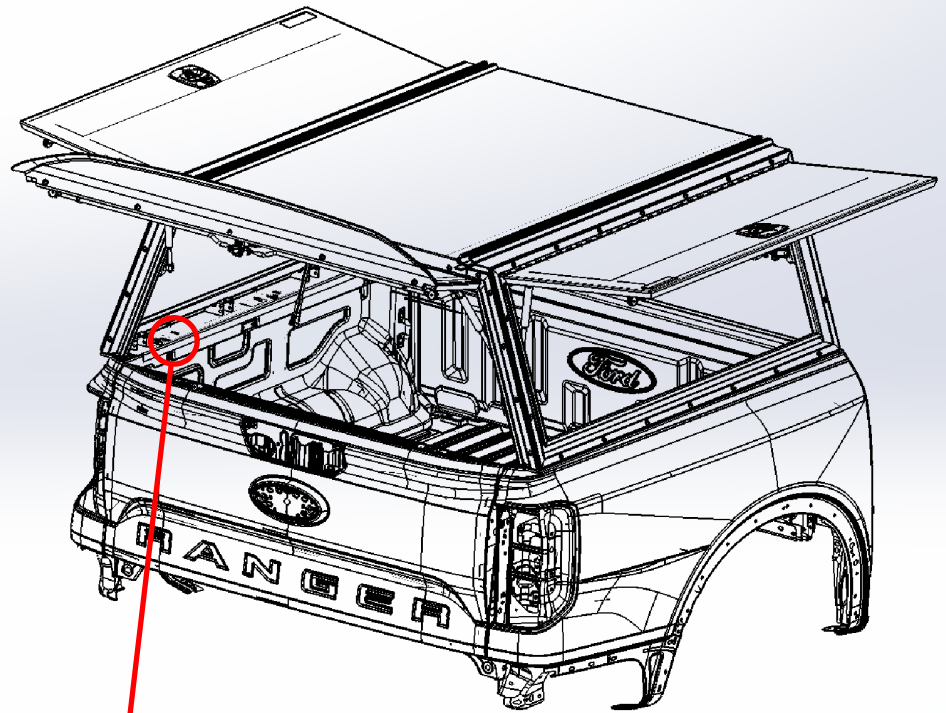

Step 10.2 ALT  
USE HOLES IN THE  
BED RAIL TO  
MARK AND DRILL  
MOUNTING  
LOCATIONS. IT IS  
NOT NECESSARY  
TO REMOVE THE  
TOPPER FOR THIS  
STEP.

(8 PLACES)  
11/32" DRILL BIT



NOTE: IF THESE  
HOLES INTERFERE  
WITH THE OEM  
BODY, DRILL A  
NEW HOLE IN THE  
BED RAIL +/- 2"  
FROM THE  
INTERFERENCE.

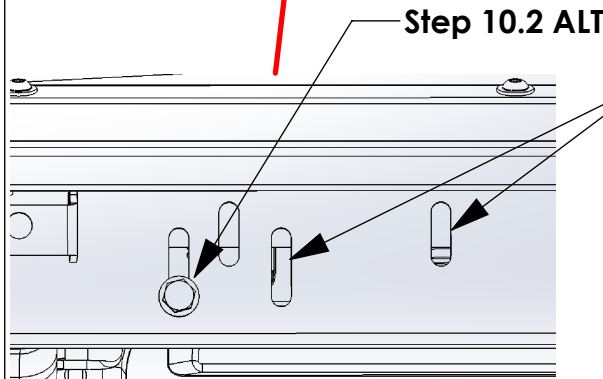

NOTE:  
OUTER SLOTS ARE TO BE USED  
WITH 2026 FORD RANGER  
INNER AND SMALLER SLOTS  
TO BE USED WITH 2025 FORD  
RANGER

Step 10.1

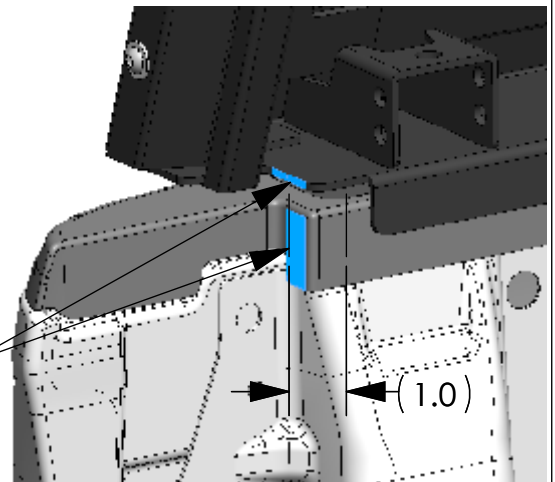

### STEP 10 - ATTACH TOPPER TO TRUCK BED



NOTE: (FOR 8.0' 26" TALL RAM 1500, 2500, 3500 ONLY) TOPPER MUST BE SOFT INSTALLED TO MARK FOR DRILLING. TOPPER TO BE REMOVED PRIOR TO DRILLING.

**Step 10.3**  
USING THE HOLES YOU JUST DRILLED OUT, FASTEN THE TOPPER TO THE TRUCK BED.  
FAS0242,  
FAS0552 [x2],  
FAS0248

(8 PLACES)  
1/2" SOCKET  
1/2" WRENCH

**Step 10.4**  
ADD TO BOTH SIDES SILICONE BETWEEN FRONT PANEL GAP AND BED RAIL, AND REAR OF TOPPER.

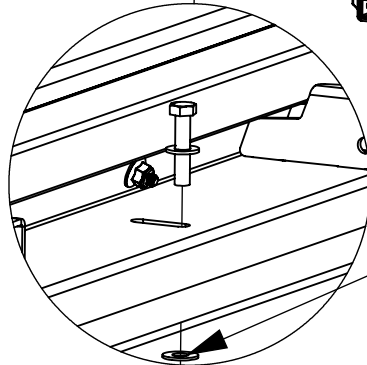
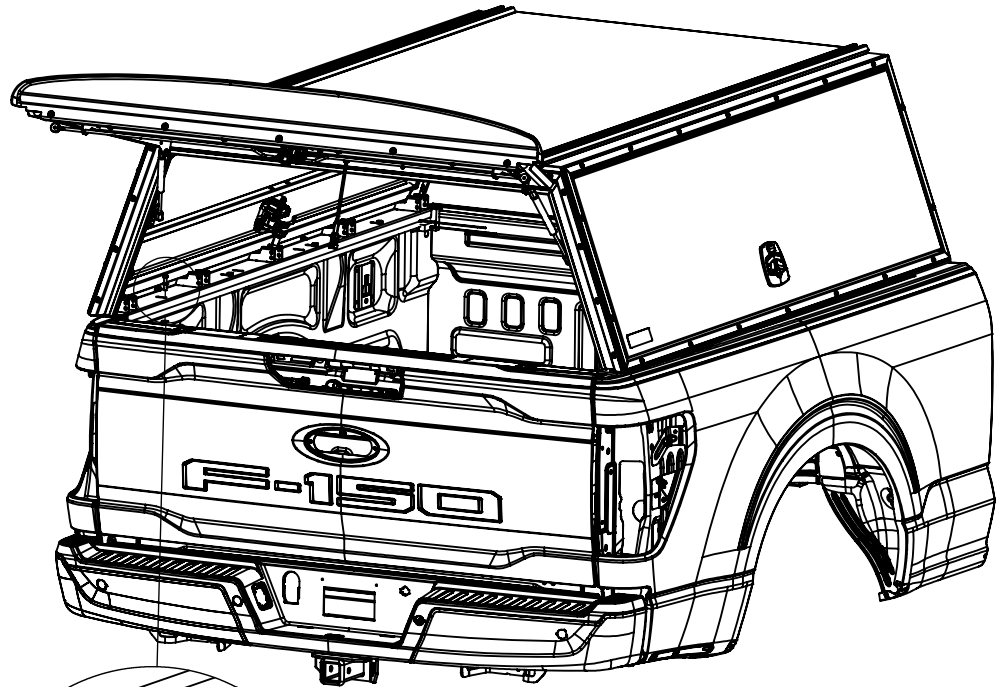

Step 10.3



Step 10.4



**MAKE SURE ALL FASTENERS ARE TIGHTENED!! INSTALLATION IS COMPLETE**

### STEP 10 ( CON'T) - ATTACH TOPPER TO TRUCK BED



NOTE: (FOR 8.0' 26" TALL RAM 1500, 2500, 3500 ONLY) TOPPER MUST BE SOFT INSTALLED TO MARK FOR DRILLING. TOPPER TO BE REMOVED PRIOR TO DRILLING.

Step 10.4  
COLORADO  
TOPPER.  
ALIGNMENT IS  
BASED OFF OF  
THE TAILGATE  
AND THE SIDE BED  
RAILS.

THESE 2 FACES  
SHOULD BE  
ALIGNED.

Step 10.5  
USING THE HOLES  
YOU JUST DRILLED  
OUT, FASTEN THE  
TOPPER TO THE  
TRUCK BED.  
FAS0242,  
FAS0552 [x2],  
FAS0248

(6 PLACES)  
1/2" SOCKET  
1/2" WRENCH

NOTE: IT IS RECOMMENDED THAT YOU LOAD THE TOPPER ONTO A TRUCKBED WITH ONE OF THE FOLLOWING METHODS:

- HOIST: ATTACH TO THE ROOF RAILS OF THE TOPPER
- FORKLIFT: OPEN THE REAR DOOR AND SET FORKS ON THE ROOF BOWS
- MANUAL: HAVE 1 INDIVIDUAL AT EACH CORNER OF THE TOP AND CARRY OVER THE SIDES OF THE TRUCK. DO NOT SCRATCH THE VEHICLE.

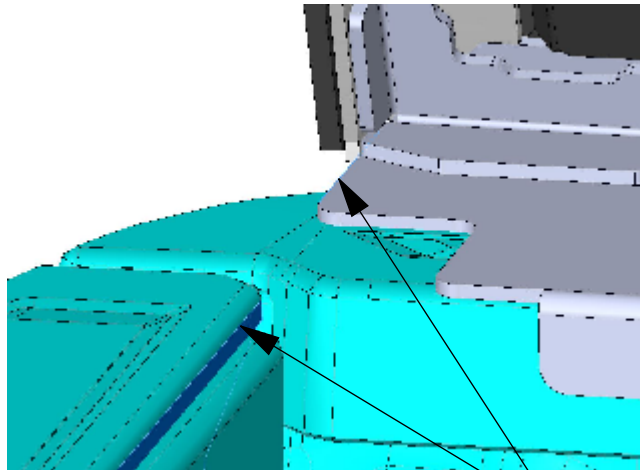

Step 10.4  
IN LINE

STEP 10.5  
INSIDE SLOTS FOR  
THE COLORADO

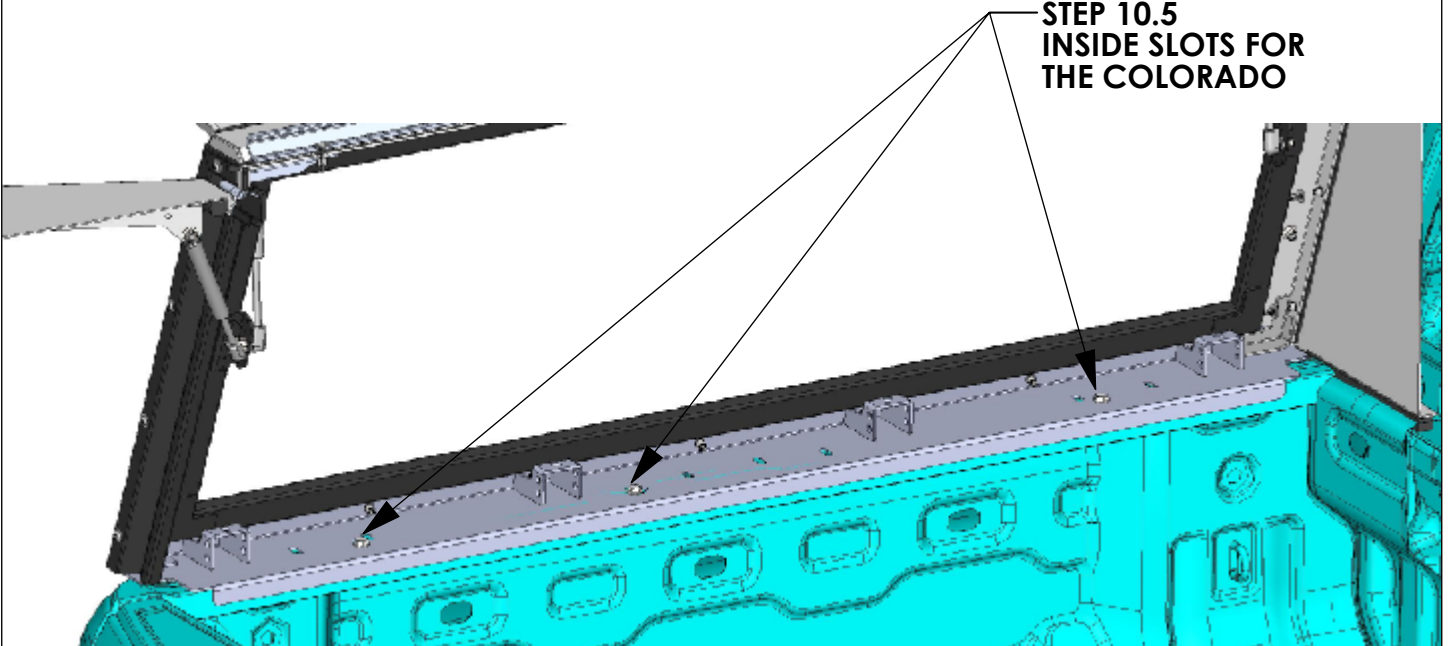

**MAKE SURE ALL FASTENERS ARE TIGHTENED!! INSTALLATION IS COMPLETE**

**Introduction / Comments:**

Install Instructions For Brake Light On Topper For F150 (5.5'/6.5' & 8')

**Note:**

Read all instructions prior to installation. Review the Adrian Steel **GENERAL PRECAUTIONS PAGES (56638)** before attempting installation. Only personnel familiar with using electrical best practices should perform this install. Reference **ELECTRICAL BEST PRACTICES MANUAL (54479)** before attempting installation.

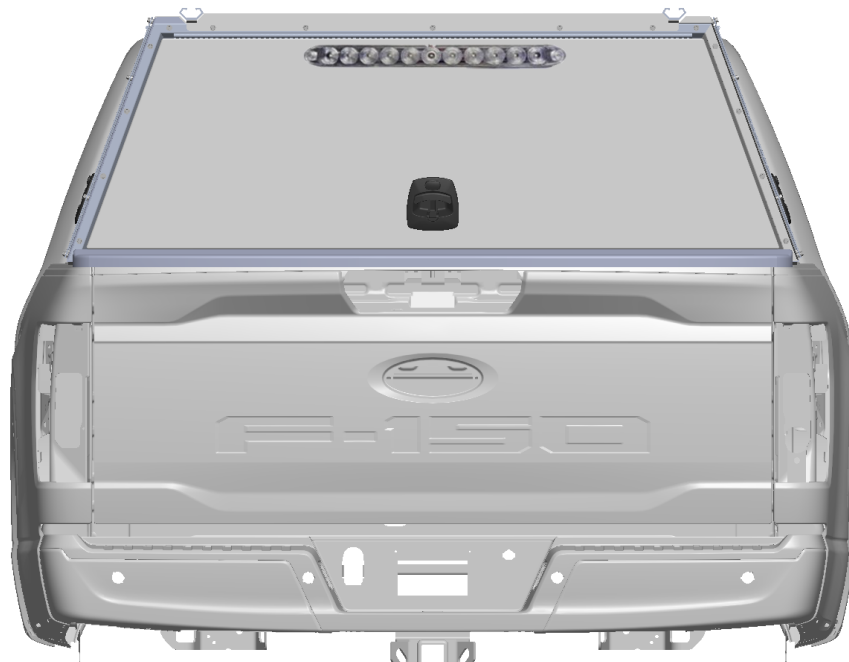

**Installation Instructions For Brake Light On  
Topper For F150 (5.5'/6.5' & 8')**

# Routing Overview

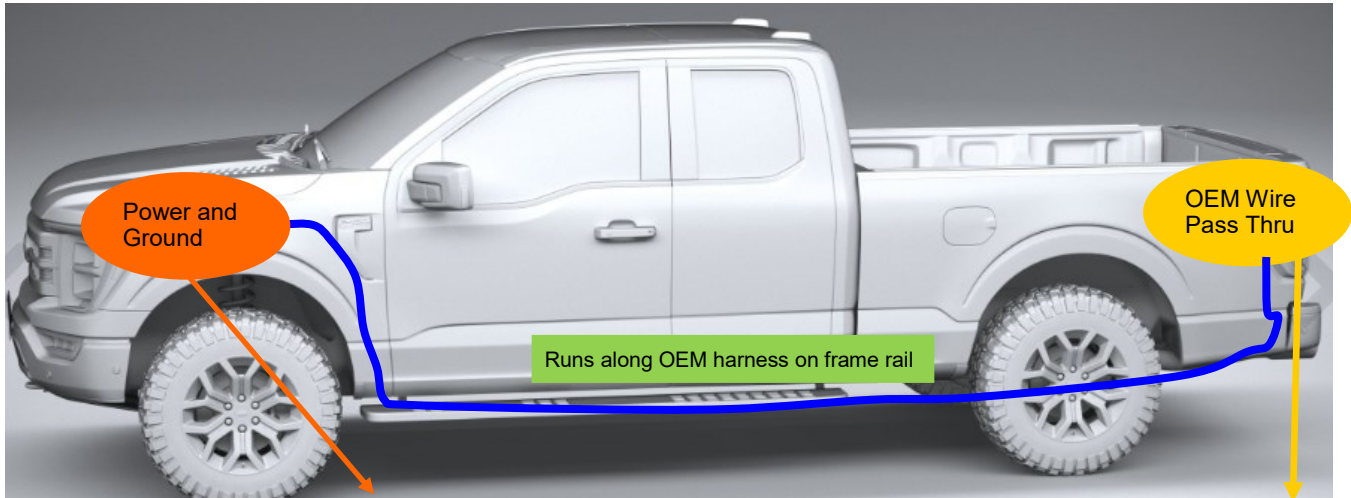

Color	Key - Items
Orange	Power and Ground Location
Blue	Harness Routing
Yellow	Bed Wire Pass Thru

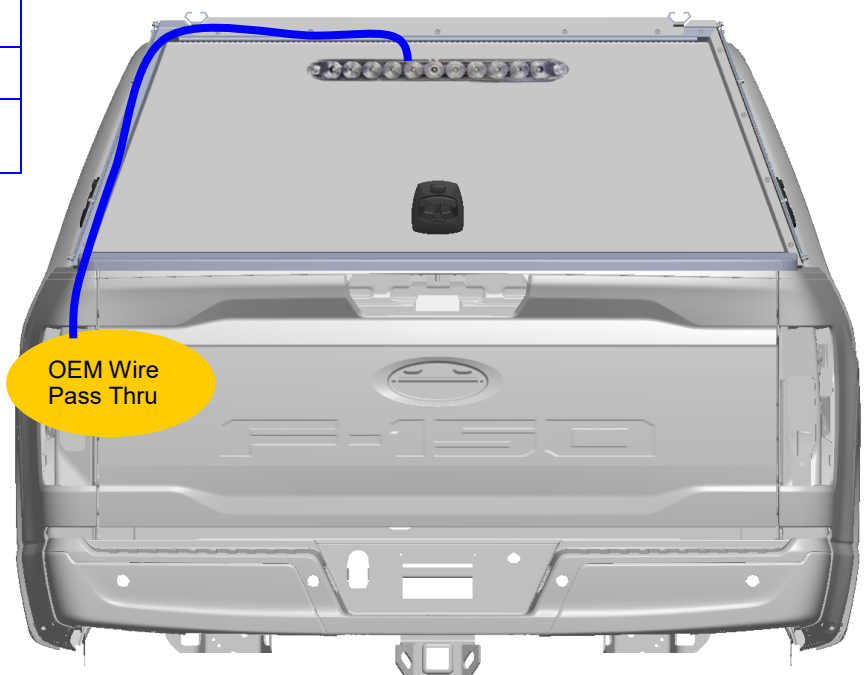



**Step 1:** Locate the brake light harness 71668.

Remove the fuse from the inline fuse holder until the end of the install.

**Step 2:** Open the vehicle hood.

Locate the driver's side frame OEM harness. Follow the harness forward of the truck, until you reach the hood shock area.

There will be a small grey/orange wire separate from the OEM harness. It will have a black covering on the end.

\*\*\* Please note the Hybrid F150 may have a green/purple wire instead of grey/orange.

This is the OEM CHMSL circuit wire for the brake light.

Strip the wire covering and prepare it to be connected to the brake light harness.

Locate the end of the harness (PN71668) with the ring terminal and butt connector.

Use the butt connector to connect to the OEM CHMSL wire. Use a heat gun to shrink the butt connector once crimped on.

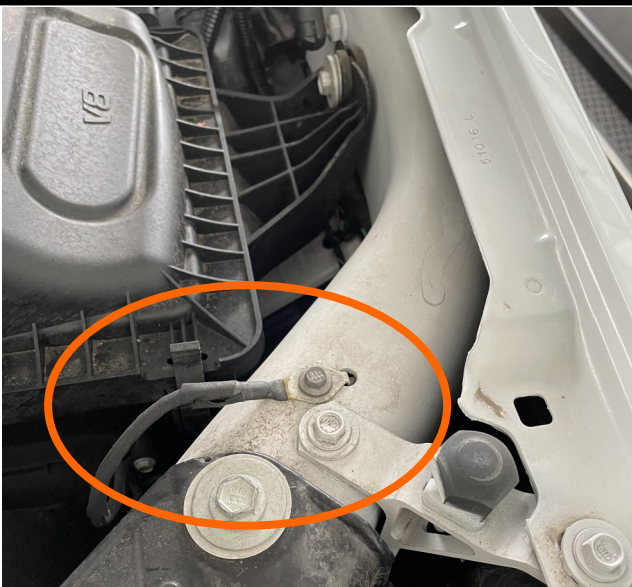

**Step 3:** Locate the OEM chassis ground located on the frame—forward of the CHMSL circuit.

Secure the ring terminal on the brake light harness to the chassis ground.

Torque the ground to 9Nm (80 in lb).

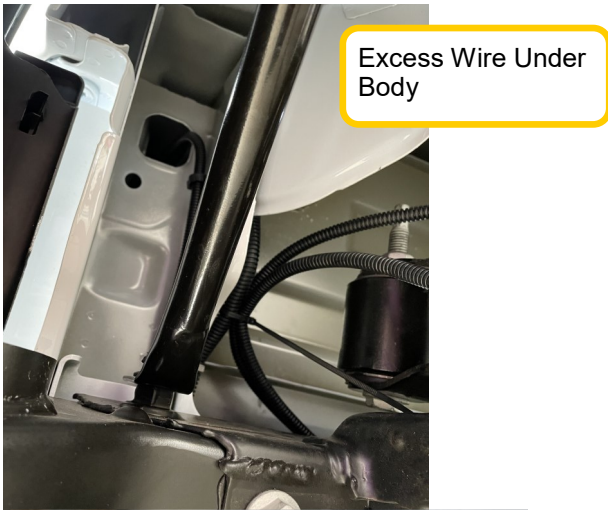

**Step 4: Routing (Refer to routing diagrams at the beginning of the instructions)**

Route the brake light harness rearward and down the engine compartment to the frame (red dotted line).

Follow the OEM wire harness on the frame rearward to the bumper of the truck.

Continue routing the harness upward in the bed cavity, to the bed wire pass thru.

Drill a hole in the OEM grommet, for the pass thru. If the grommet has a light in place of it, please utilize the round hole that is up and to the right of it.

If installing the interior lighting kit as well as the brake light kit, utilize the larger grommet supplied in the brake light harness bag.

If only installing the brake light harness, utilize the smaller grommet supplied in the brake light harness kit.

Drill (for larger grommet a 1" hole and 0.625" (5/8) hole for the smaller grommet) then route the wire harness through the grommet, to the underbody of the truck.

Silicone after routing through the grommet.

Tuck any excess wiring into the empty cavity underneath the bed frame.

For **REV B** of the harnesses there will be a tek screw and p-clip supplied in the bag. Bundle the excess wire in the cavity using zip ties. Use the tek screw and p-clip to secure the bundle to the frame.

Secure the wiring with zip ties.

**DO NOT secure wiring to any brake lines.**

Be sure the bundle of wire is secure and will not fall out over time.



**Step 5: Routing continued**

Continue routing the brake light harness inside the topper, to the light.

The harness should run along the driver's side rear cavity, then across the top cavity to the light. (Red and blue lines shown in pictures)

Be sure to leave extra wire from the brake light to the topper rails before securing. This ensures the wires wont brake when the topper door opens and closes.

Clean the topper corner channel with alcohol pads or spray. Secure using zip ties and sticky back zip tie holders.

**Connect the harness to the light:**

Plug the connectors together. Pull connectors lightly to ensure they do not come apart.

Be sure the red wire on the harness connects to the black wire on the light. Then the black wire on the harness connects to the white wire on the light.

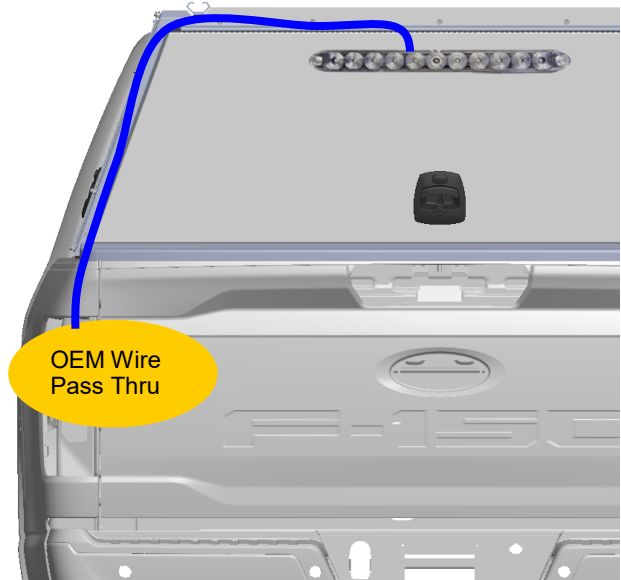

**Insert the fuse into the inline-fuse holder on the brake light harness.**

**The install is now complete.**

**Check that the brake light comes on when the brake pedal is pushed, then back off once pedal is released.**