

INSTR. NUMBER : **71622** PG: **1** REV: **U**

PART NUMBER : **TFK__T178HM23W**

PART DESC. : ASM INS, TFK__T178HM23W

BOM FOR 6.5' F-150

ITEM NO.	PART NUMBER	DESCRIPTION	QTY.
1	TSK78M23W	TOP, SIDE KIT,78",M,23,W	2
2	TCK78HM23W	TOP,CLOSE KIT,78",HM23,W	1
3	TRK7823W	TOP, ROOF KIT,78",23,W	1
4	THKFDT178M23	HDW KIT, TFKFDT178HM23W	1
5	TMLHK	Topper Mechanical Lock Hatch Kit	1

*** E-LOCK VERSION SWAP TMLHK WITH TELH05**

BOM FOR 6.5' SILVERADO 1500

ITEM NO.	PART NUMBER	DESCRIPTION	QTY.
1	TSK78M23W	TOP, SIDE KIT,78",M,23,W	2
2	TCK78HM23W	TOP,CLOSE KIT,78",HM23,W	1
3	TRK7823W	TOP, ROOF KIT,78",23,W	1
4	THKGMT178M23	HDW KIT, TFKGMT178HM23W	1
5	TMLHK	Topper Mechanical Lock Hatch Kit	1

*** E-LOCK VERSION SWAP TMLHK WITH TELH02**

NOTE: THESE INSTRUCTIONS ARE VALID FOR ALL TFK FULL TOPPER KITS. A FEW BOM KITS ARE SHOWN FOR REFERENCE ONLY.

INSTRUCTIONS SHOWS F-150 BODY DURING INSTALLATION

FASTENER AND HOLE COUNTS MAY BE DIFFERENT BETWEEN TOPPER KITS.

**E-LOCK VERSIONS:
SWAP M WITH E IN PART NUMBER
EXAMPLE: TFKFDT178HM23W
BECOMES TFKFDT178HE23W**

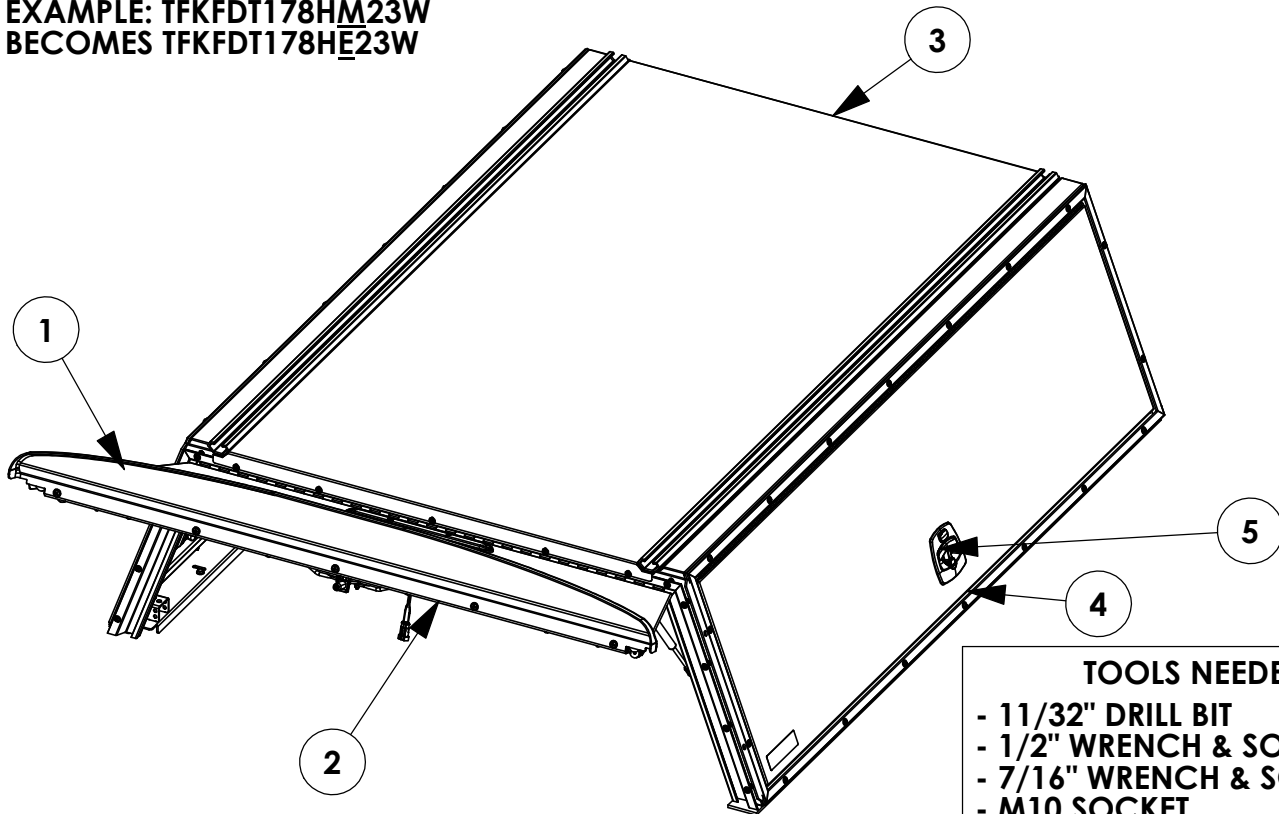

TOOLS NEEDED:

- 11/32" DRILL BIT
- 1/2" WRENCH & SOCKET
- 7/16" WRENCH & SOCKET
- M10 SOCKET
- M8 SOCKET
- M4 ALLEN
- 3/16" ALLEN
- 5/32" ALLEN
- DRIVE RATCHET / IMPACT
- SCISSORS
- TAPE MEASURE
- ALIGNMENT PUNCH

INSTR. NUMBER : 71622	PG: 2	REV: T
PART NUMBER : TFK__T178HM23W		
PART DESC. : ASM INS, TFK__T178HM23W		

**E-LOCK VERSIONS:
 SWAP M WITH E IN PART NUMBER
 EXAMPLE: TFKFDT178HM23W
 BECOMES TFKFDT178HE23W**

BOM FOR 6.3' RAM

ITEM NO.	PART NUMBER	DESCRIPTION	QTY.
1	TCK78HM23W	TOP,CLOSE KIT,78",HM23,W	1
2	THKRAM175M23	HDW KIT, TCKRAMT175HM23W	1
3	TRK7523W	TOP, ROOF PANEL KIT, RAM	1
4	TSK75M23W	TOP, SIDE KIT, 78' RAM	2
5	TMLHK	Topper Mechanical Lock Hatch Kit	1

*** E-LOCK VERSION SWAP TMLHK WITH TELH02**

BOM FOR 5.7' RAM

ITEM NO.	PART NUMBER	DESCRIPTION	QTY.
1	TSK66M23W	TOP, SIDE KIT,66",M,23,W	2
2	TCK78HM23W	TOP,CLOSE KIT,78",HM23,W	1
3	TRK6623W	TOP, ROOF KIT,66",23,W	1
4	THKRAM167M23	HDW KIT, TFKRAM167HM23W	1
5	TMLHK	Topper Mechanical Lock Hatch Kit	1

*** E-LOCK VERSION SWAP TMLHK WITH TELH01**

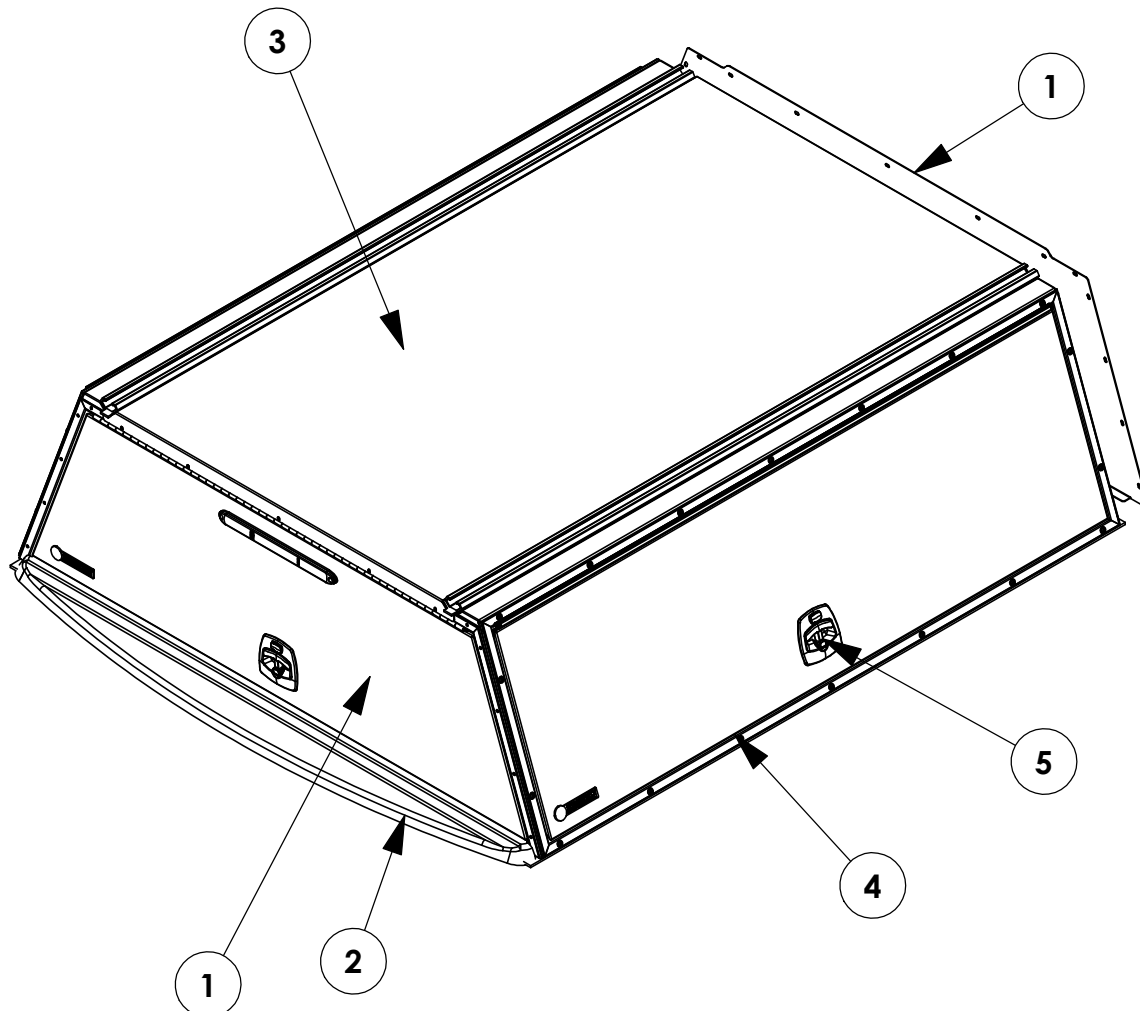

INSTR. NUMBER : 71622	PG: 3	REV: T
PART NUMBER : TFK__T196HM23W		
PART DESC. : ASM INS, TFK__T178HM23W		

**E-LOCK VERSIONS:
SWAP M WITH E IN PART NUMBER
EXAMPLE: TFKFDT178HM23W
BECOMES TFKFDT178HE23W**

BOM FOR 8.0' 23" TALL FORD F-150, F-250, F-350

ITEM NO.	PART NUMBER	DESCRIPTION	QTY.
1	TSK96M23W	TOP, SIDE KIT,96",M,23,W	2
2	TCK78HM23W	TOP,CLOSE KIT,78",HM23,W	1
3	TRK9623W	TOP, ROOF KIT,96",23,W	1
4	THKFDT196M23	HDW KIT, TFKFDT196HM23W	1
5	TMLHK	Topper Mechanical Lock Hatch Kit	1

*** E-LOCK VERSION SWAP TMLHK WITH TELH06**

BOM FOR 8.0' 23" TALL SILVERADO 1500, 2500, 3500

ITEM NO.	PART NUMBER	DESCRIPTION	QTY.
1	TSK96M23W	TOP, SIDE KIT,96",M,23,W	2
2	TCK78HM23W	TOP,CLOSE KIT,78",HM23,W	1
3	TRK9623W	TOP, ROOF KIT,96",23,W	1
4	THKGMT196M23	HDW KIT, TFKGMT196HM23W	1
5	TMLHK	Topper Mechanical Lock Hatch Kit	1

*** E-LOCK VERSION SWAP TMLHK WITH TELH03**

BOM FOR 8.0' 23" TALL RAM 1500, 2500, 3500

ITEM NO.	PART NUMBER	DESCRIPTION	QTY.
1	TSK96M23W	TOP, SIDE KIT,96",M,23,W	2
2	TCK78HM23W	TOP,CLOSE KIT,78",HM23,W	1
3	TRK9623W	TOP, ROOF KIT,96",23,W	1
4	THKRAM196M23	HDW KIT, TFKRAM196HM23W	1
5	TMLHK	Topper Mechanical Lock Hatch Kit	1

*** E-LOCK VERSION SWAP TMLHK WITH TELH03**

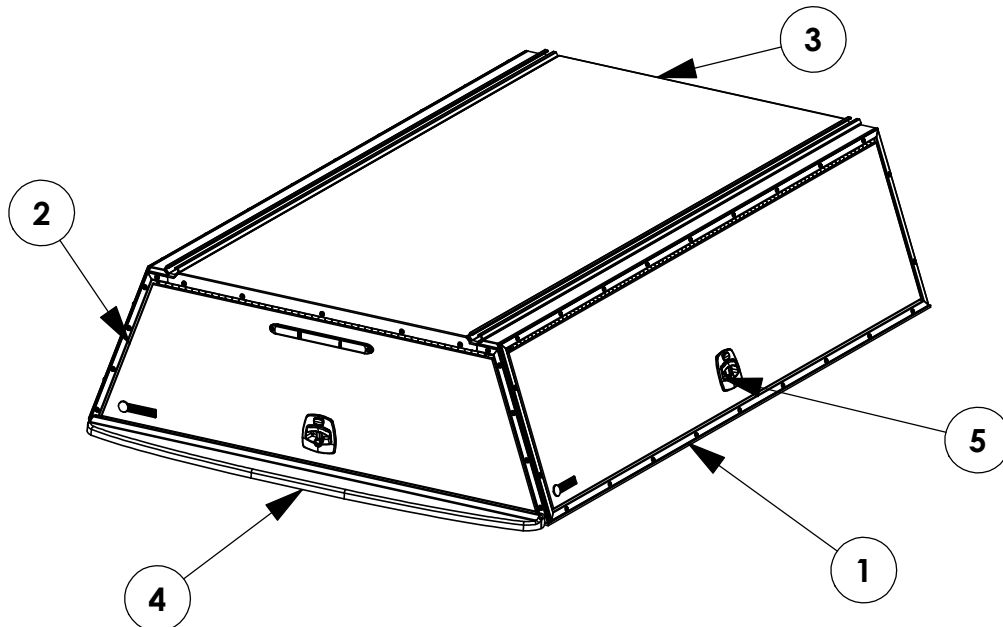

INSTR. NUMBER : 71622	PG: 4	REV: T	BOM FOR 8.0' 26" TALL FORD F-150, F-250, F-350			
	PART NUMBER : TFK__T296HM26W		ITEM NO.	PART NUMBER	DESCRIPTION	QTY.
PART DESC. : ASM INS, TFK__T178HM23W		1	TSK96M26W	TOP, SIDE KIT,96",M,26,W	2	
		2	TCK80HM26W	TOP,CLOSE KIT,80",HM263,W	1	
		3	TRK9623W	TOP, ROOF KIT,96",23,W	1	
		4	THKFDT296M26	HDW KIT, TFKFDT296HM26W	1	
		5	TMLHK	Topper Mechanical Lock Hatch Kit	1	

E-LOCK VERSIONS:
SWAP M WITH E IN PART NUMBER
EXAMPLE: TFKFDT178HM23W
BECOMES TFKFDT178HE23W

*** E-LOCK VERSION SWAP TMLHK WITH TELH06**

BOM FOR 8.0' 26" TALL SILVERADO 1500, 2500, 3500

ITEM NO.	PART NUMBER	DESCRIPTION	QTY.
1	TSK96M26W	TOP, SIDE KIT,96",M,26,W	2
2	TCK80HM26W	TOP,CLOSE KIT,80",HM263,W	1
3	TRK9623W	TOP, ROOF KIT,96",23,W	1
4	THKGMT296M26	HDW KIT, TFKGMT296HM26W	1
5	TMLHK	Topper Mechanical Lock Hatch Kit	1

*** E-LOCK VERSION SWAP TMLHK WITH TELH03**



BOM FOR 8.0' 26" TALL RAM 1500, 2500, 3500
NOTE: SPECIAL ASSEMBLY INSTRUCTION SHOWN ON SHEET 20

ITEM NO.	PART NUMBER	DESCRIPTION	QTY.
1	TSK96M26W	TOP, SIDE KIT,96",M,26,W	2
2	TCK80HM26W	TOP,CLOSE KIT,80",HM263,W	1
3	TRK9623W	TOP, ROOF KIT,96",23,W	1
4	THKRAM296M26	HDW KIT, TFKRAM296HM26W	1
5	TMLHK	Topper Mechanical Lock Hatch Kit	1

*** E-LOCK VERSION SWAP TMLHK WITH TELH03**

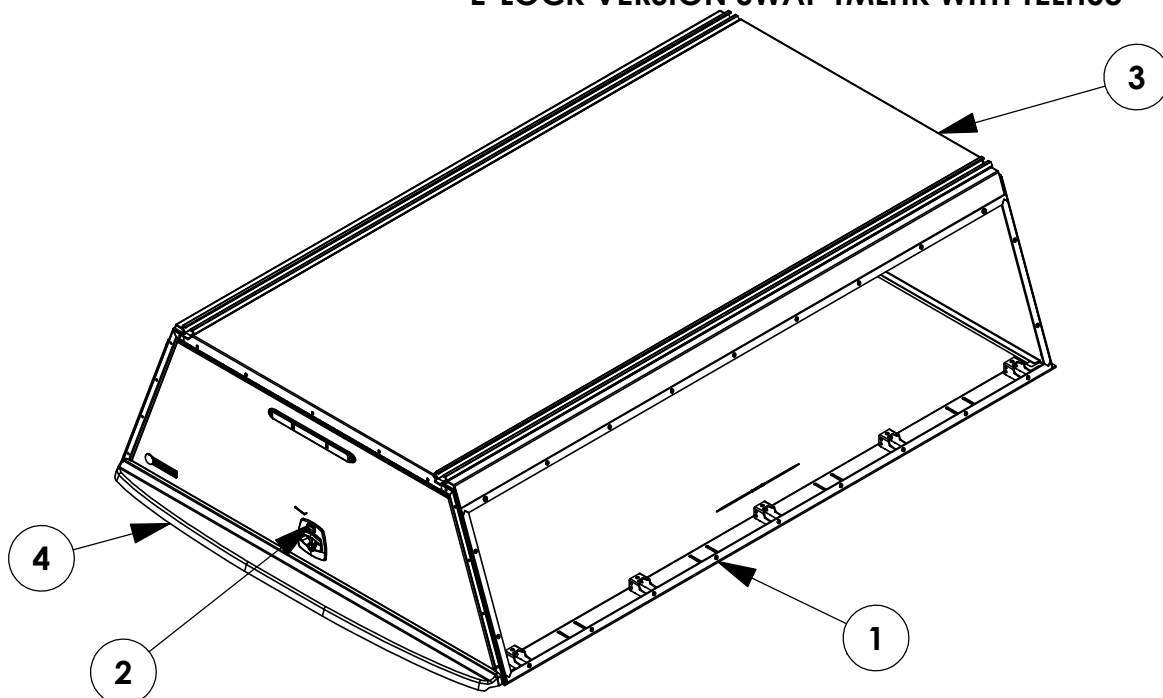

INSTR. NUMBER : **71622** PG: **5** REV: **T**

PART NUMBER : **TFKFDT166HM23W**

PART DESC. : ASM INS, TFK__T178HM23W

BOM FOR 5.5' 23" TALL FORD F-150 LIGHTNING/ICE

ITEM NO.	PART NUMBER	DESCRIPTION	QTY.
1	TSK66M23W	TOP, SIDE KIT,66",M,23,W	2
2	TCK78HM23W	TOP,CLOSE KIT,78",HM23,W	1
3	TRK6623W	TOP, ROOF KIT,66",23,W	1
4	THKFDT166M23	HDW KIT, TFKFDT166HM23W	1
5	TMLHK	Topper Mechanical Lock Hatch Kit	1

E-LOCK VERSION: TFKFDT166HE23W

*** E-LOCK VERSION SWAP TMLHK WITH TELH04**

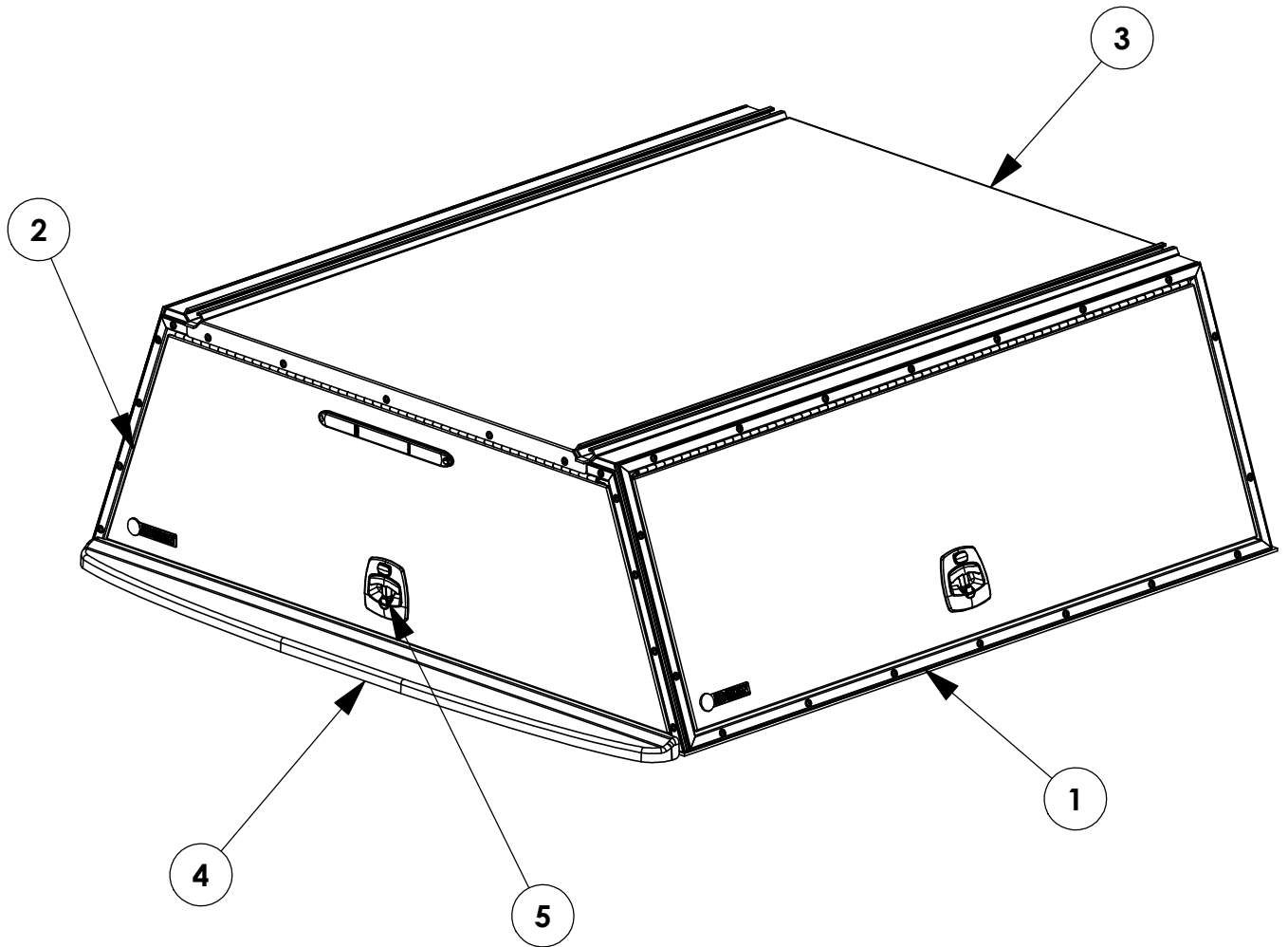

INSTR. NUMBER : 71622		PG: 6	REV: T	BOM FOR 5' FORD RANGER		
PART NUMBER : TFKRNG160HM23W		ITEM NO.	PART NUMBER	DESCRIPTION	QTY.	
PART DESC. : ASM INS, TFK__T178HE23W		1	TSKRNG60M23W	TOP, SIDE KIT, 60", RANGER, M, 23, W	2	
		2	TCK72HM23W	TOP, CLOSE KIT, 72", HM23, W	1	
		3	TRK6023W	TOP, ROOF KIT, 60", 23, W	1	
		4	THKRNG160M23	HDW KIT, TFKNFT172HM23W	1	
		5	TMLHK	TOPPER MECHANICAL LOCK HATCH KIT	1	

E-LOCK VERSION: TFKRNG160HE23W

*** E-LOCK VERSION SWAP TMLHK WITH TELH04**

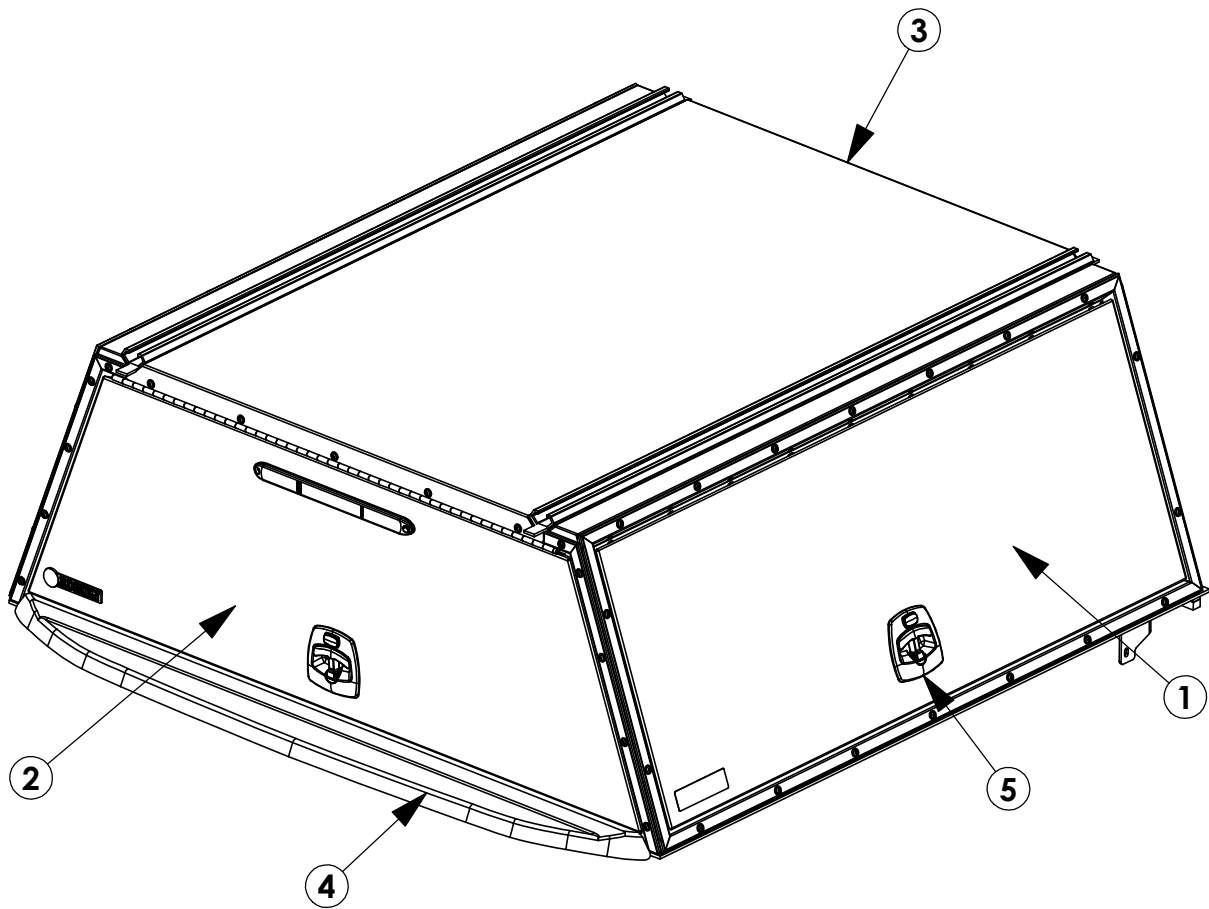

INSTR. : 71622
 NUMBER : 7 T

PG: 7 REV: T

PART : TFKNFT172HM23W
 NUMBER :

PART :
 DESC. : ASM INS, TFK__T178HM23W

BOM FOR 6.0' 23" TALL NISSAN FRONTIER

ITEM NO.	PART NUMBER	DESCRIPTION	QTY.
1	TSK72M23W	TOP, SIDE KIT,72",M,23,W	2
2	TCK72HM23W	TOP,CLOSE KIT,72",HM23,W	1
3	TRK7223W	TOP, ROOF KIT,72",23,W	1
4	THKNFT172M23	HDW KIT, TFKNFT172HM23W	1
5	TMLHK	Topper Mechanical Lock Hatch Kit	1

E-LOCK VERSION: TFKNFT172HE23W

*** E-LOCK VERSION SWAP TMLHK WITH TELH05**

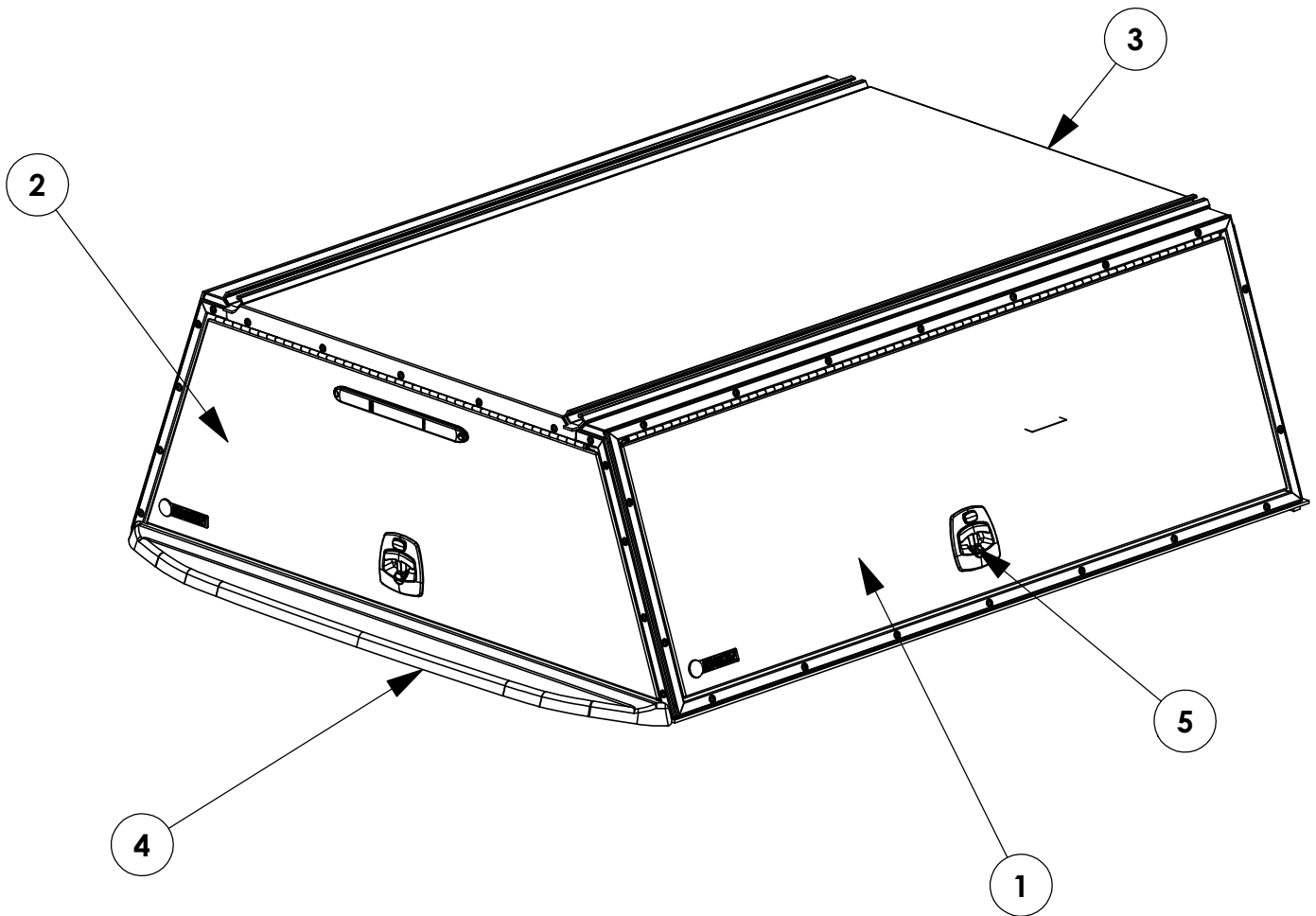

INSTR. NUMBER : 71622	PG: 8	REV: T
PART NUMBER : TFKNFT160HM23W		
PART DESC. : ASM INS, TFK__T178HM23W		

BOM FOR 5.0' 23" TALL NISSAN FRONTIER

ITEM NO.	PART NUMBER	DESCRIPTION	QTY.
1	TSK60M23W	TOP, SIDE KIT,60",M,23,W	2
2	TCK72HM23W	TOP,CLOSE KIT,72",HM23,W	1
3	TRK6023W	TOP, ROOF KIT,60",23,W	1
4	THKNFT172M23	HDW KIT, TFKNFT172HM23W	1
5	TMLHK	Topper Mechanical Lock Hatch Kit	1

**E-LOCK VERSIONS:
SWAP M WITH E IN PART NUMBER
EXAMPLE: TFKFDT178HM23W
BECOMES TFKFDT178HE23W**

*** E-LOCK VERSION SWAP TMLHK WITH TELH04**

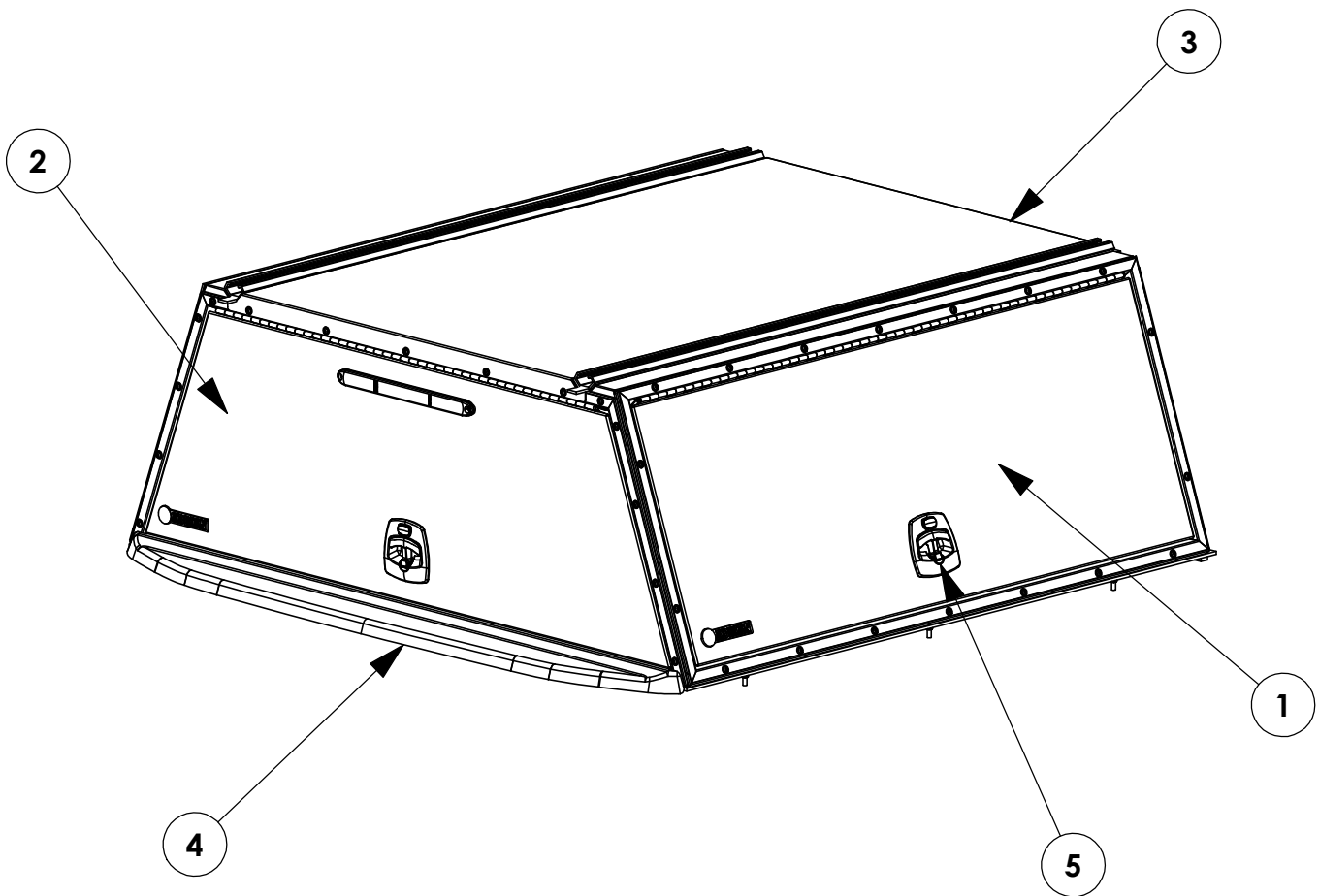

INSTR. NUMBER : 71622		PG: 9	REV: T	BOM FOR 5.1' 23" TALL COLORADO		
PART NUMBER : TFKNFT160HM23W		ITEM NO.	PART NUMBER	DESCRIPTION	QTY.	
PART DESC. : ASM INS, TFK__T178HM23W		1	TSKCOL60M23W	TOP, SIDE KIT, 60", M, 23, W	2	
		2	TCK72HM23W	TOP, CLOSE KIT, 72", HM23, W	1	
		3	TRK6123W	TOP, ROOF KIT, 61", 23, W	1	
		4	THKCOL60M23	HDW KIT, TFKCOL160HM23W	1	
		5	TMLHK	Topper Mechanical Lock Hatch Kit	1	

E-LOCK VERSIONS:
SWAP M WITH E IN PART NUMBER
EXAMPLE: TFKFDT178HM23W
BECOMES TFKFDT178HE23W

*** E-LOCK VERSION SWAP TMLHK WITH TELH04**

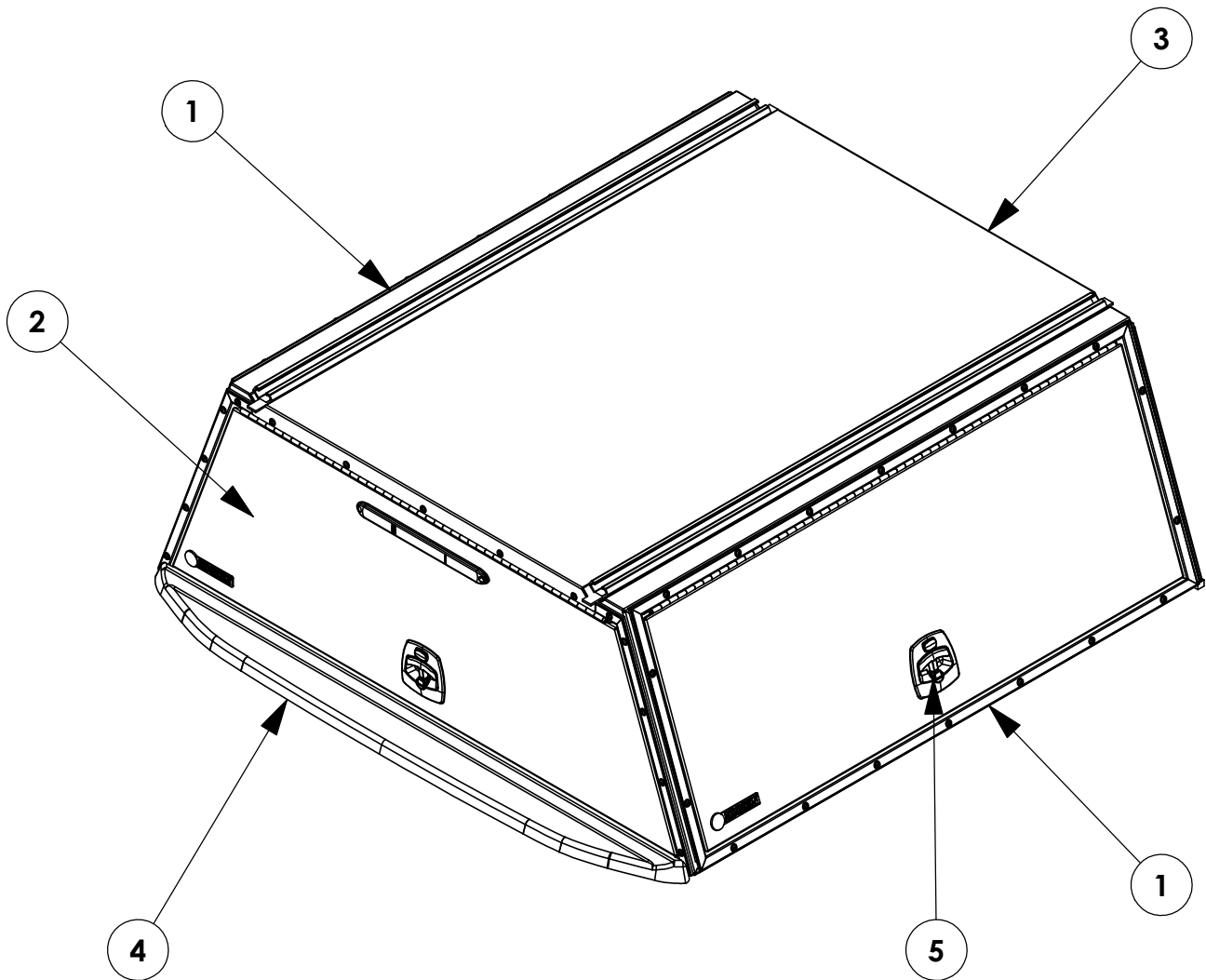

INSTR. NUMBER : 71622		PG: 10	REV: T	BOM FOR 69" 23" TALL SILVERADO EV 1500			
PART NUMBER : TFKGME169HM23W		ITEM NO.	PART NUMBER	DESCRIPTION	QTY.		
PART DESC. : ASM INS, TFKGME169HM23W		1	TSK69M23WPS	TOP, SIDE KIT,SILVERADO EV, 69", PS	1		
E-LOCK VERSIONS: SWAP <u>M</u> WITH <u>E</u> IN PART NUMBER EXAMPLE: TFKFDT178HM23W BECOMES TFKFDT178H <u>E</u> 23W		2	TSK69M23WDS	TOP, SIDE KIT,SILVERADO EV, 69",DS	1		
		3	TCKGMEHM23W	TOP,CLOSE KIT,SILVERADO EV, HM23, W	1		
		4	TRKGME6923W	TOP, ROOF KIT,69",23,W	1		
		5	THKGME169M23	HDW KIT, TFKGME169HM23W	1		
		6	TMLHK	Topper Mechanical Lock Hatch Kit	1		

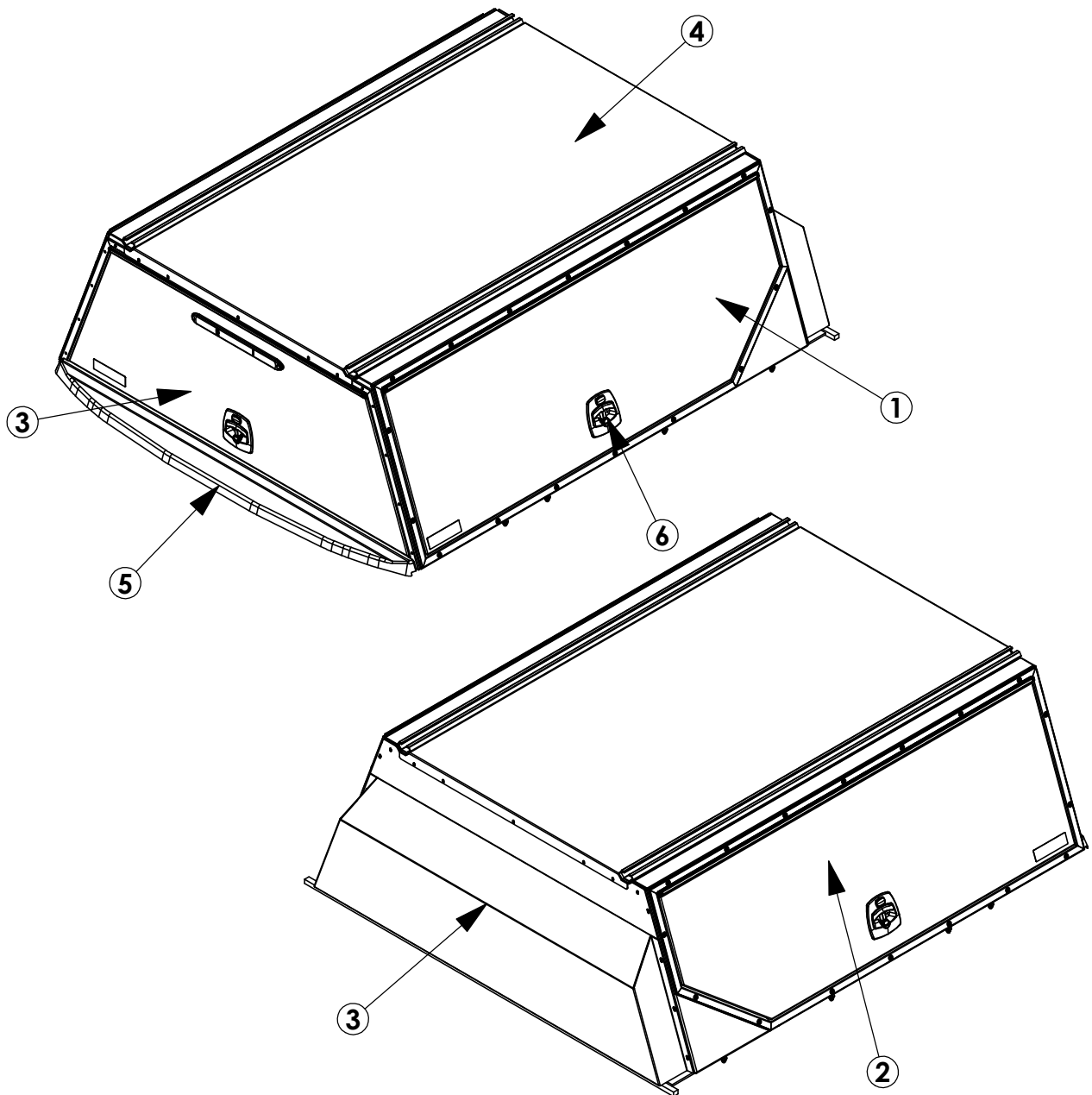

INSTR. NUMBER : 71622	PG: 11	REV: T
PART NUMBER : TFKGMT280HM23W		
PART DESC. : ASM INS, TFK__T178HM23W		

BOM FOR 80" 23" TALL SILVERADO 2500, 3500

ITEM NO.	PART NUMBER	DESCRIPTION	QTY.
1	TSK80M23W	TOP, SIDE KIT,80",M,23,W	2
2	TCK78HM23W	TOP,CLOSE KIT,78",HM23,W	1
3	TRK8026W	TOP, ROOF KIT,80",26,W	1
4	THKGMT280M23	HDW KIT, TFKGMT280HM23W	1
5	TMLHK	Topper Mechanical Lock Hatch Kit	1

**E-LOCK VERSIONS:
SWAP M WITH E IN PART NUMBER
EXAMPLE: TFKFDT178HM23W
BECOMES TFKFDT178HE23W**

*** E-LOCK VERSION SWAP TMLHK WITH TELH03**

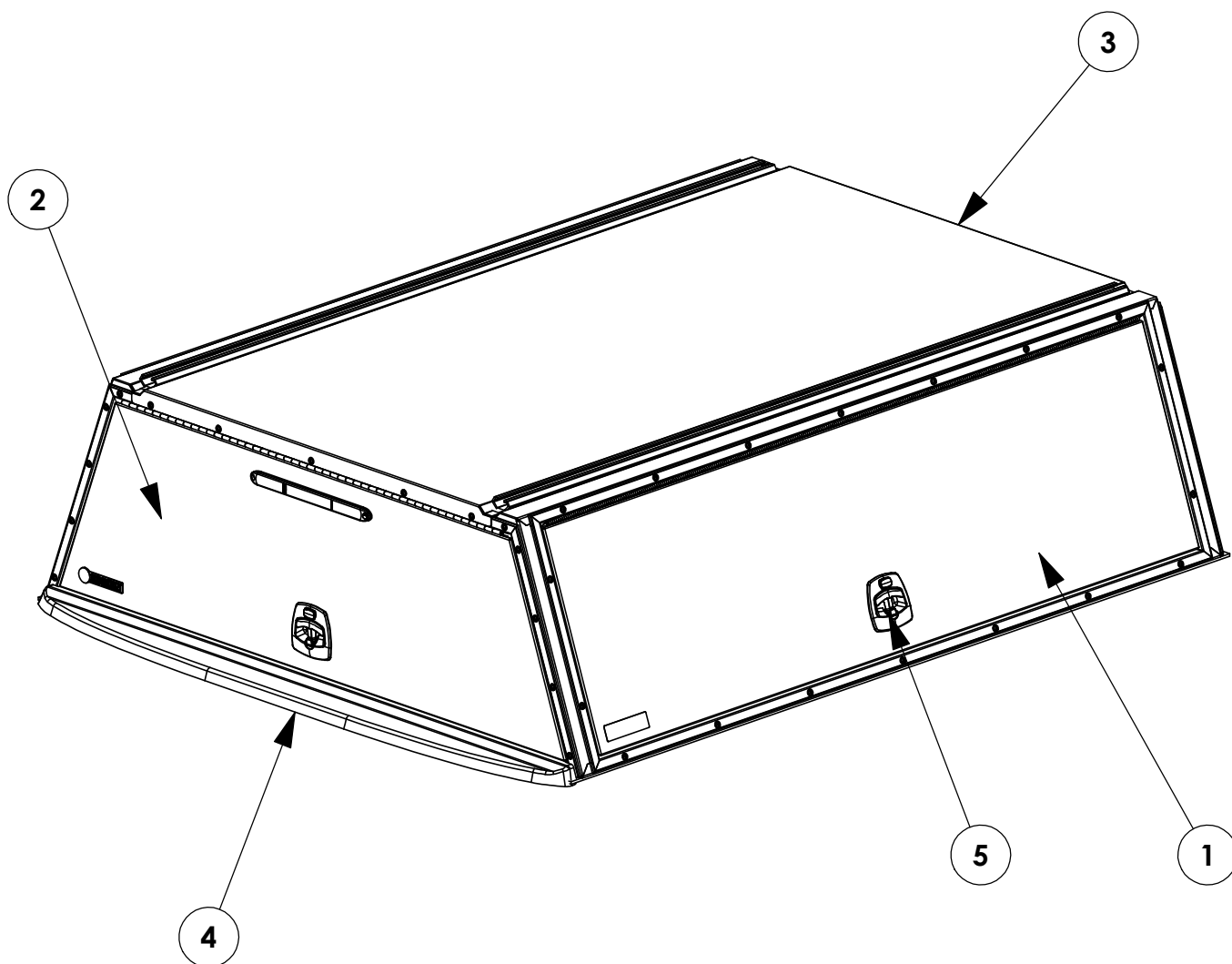

INSTR. NUMBER : **71622** PG: **12** REV: **T**

PART NUMBER : **TFKGMT170HM23W**

PART DESC. : ASM INS, TFK__T178HM23W

BOM FOR 70" 23" TALL SILVERADO 1500

ITEM NO.	PART NUMBER	DESCRIPTION	QTY.
1	TSK70M23W	TOP, SIDE KIT,70",M,23,W	2
2	TCK78HM23W	TOP,CLOSE KIT,78",HM23,W	1
3	TRK7023W	TOP, ROOF KIT,70",23,W	1
4	THKGMT280M23	HDW KIT, TFKGMT280HM23W	1
5	TMLHK	Topper Mechanical Lock Hatch Kit	1

E-LOCK VERSIONS:
SWAP M WITH E IN PART NUMBER
EXAMPLE: TFKFDT178HM23W
BECOMES TFKFDT178HE23W

*** E-LOCK VERSION SWAP TMLHK WITH TELH03**

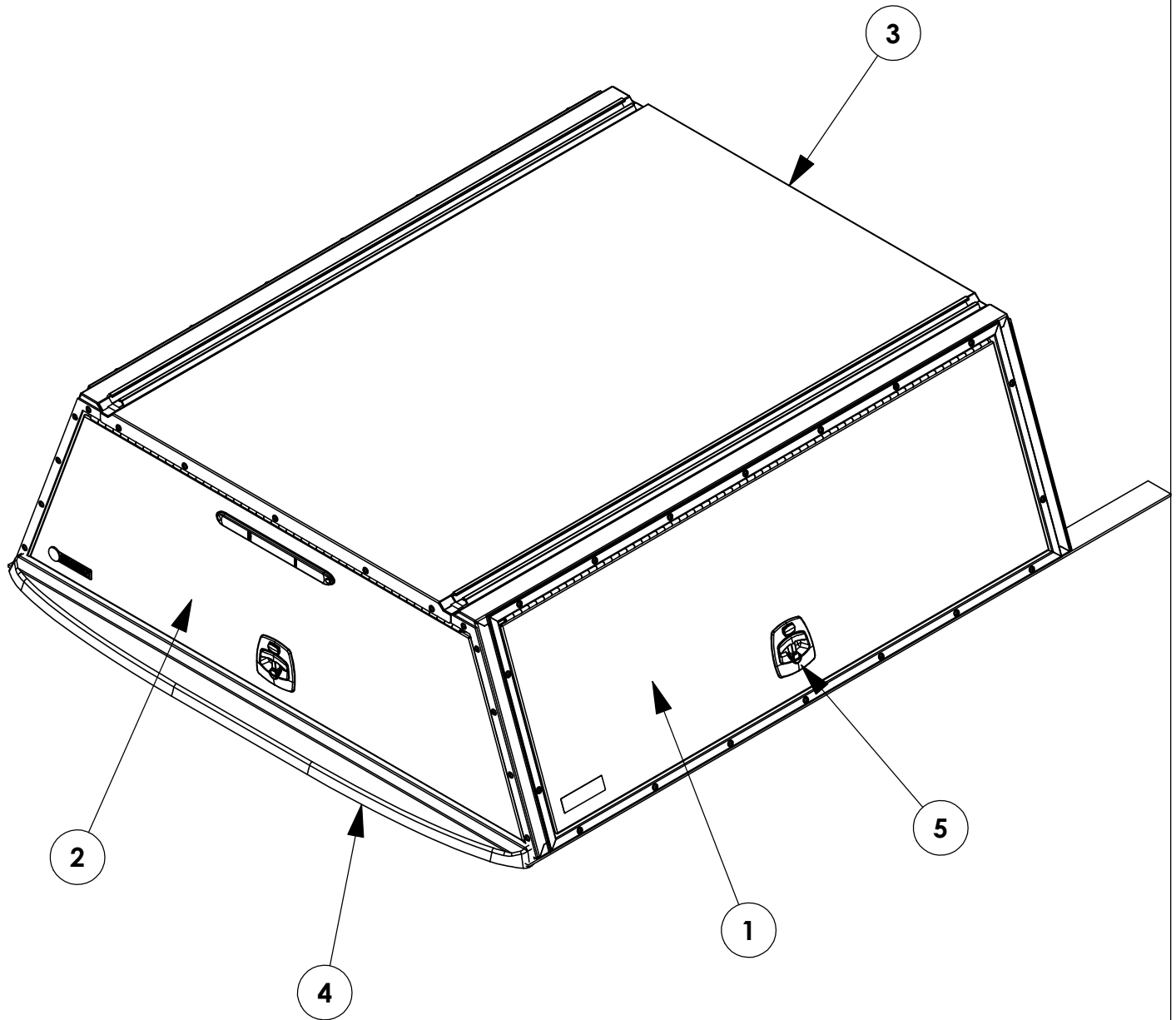

GET TO KNOW THE VEHICLE - AT THE BEGINNING OF ANY INSTALLATION, CHECK THE LOCATION OF THE FUEL TANK, FUEL LINES, BRAKE LINES, HIGH VOLTAGE BATTERIES AND WIRING HARNESSSES TO AVOID INJURY OR PROPERTY DAMAGE FROM TOOL CONTACT.

SEAL ALL EXTERIOR HOLES - ALL INSTALLATION HOLES SHOULD BE SEALED WITH BUTYL TAPE OR SILICON TO PREVENT WATER AND EXHAUST GASES FROM ENTERING THE VEHICLE.

CONTROL DRILL DEPTH - TO AVOID DAMAGE TO THE VEHICLE, USE A DRILL STOP OR CLEARED STEP BIT WHEN DRILLING INSTALLATION HOLES.

ALWAYS ADD PRIMER - WHEN ADDING INSTALLATION HOLES BE SURE TO USE A SELF-ETCHING PRIMER TO PREVENT CORROSION, FASTENER FAILURE AND INJURY.

MOUNTING POINTS MUST HAVE METAL-TO-METAL CONTACT - USE PROVIDED MOUNTING SPACERS TO ACCOMMODATE FOR VEHICLE FEATURES, CARPET OR SUBFLOORS.

PROVIDE CLEARANCE FOR SPACERS - IF THE INSTALLATION VEHICLE CONTAINS A CARPET OR SUBFLOOR, USE A 1-3/16" DIAMETER CARPET CUTTER (P/N: 31183-0) AT ALL MOUNTING LOCATIONS TO OPEN UP ROOM FOR SPACERS.

CHECK SPACER ORIENTATION - BE SURE THAT THE INDENT IN THE SPACER COVERS THE PLUSNUT HEAD; THIS ENSURES THE MOST METAL-TO-METAL CONTACT AND REDUCES VIBRATION.

PLUSNUT INSTALLATION - A PLUSNUT GUN IS RECOMMENDED FOR PLUSNUT INSTALLATION FOR ITS PRODUCTION SPEED. HOWEVER, A PLUSNUT SETTING TOOL CAN ALSO BE USED (P/N: 22200-0).

THRU-BOLT CLEARANCE - WHEN USING A THRU-BOLT AT ANY MOUNTING LOCATION, BE SURE THAT YOUR HOLE HAS 1/16" CLEARANCE.

INTENTIONALLY LEFT BLANK

FASTENERS USED

BAG REFERENCE: ALL

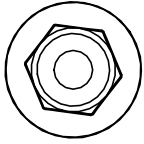

FAS0055
1/4-20 ZP
HFLNG NLK NUT
QTY: 19

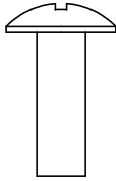

FAS0062
1/4-20 X 0.75 ZP
THP SCREW
QTY: 9

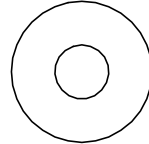

FAS0067
1/4 ZP
FLAT WASHER
QTY: 9

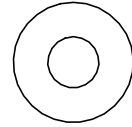

FAS0234
1/4 SST
FLAT WASHER
QTY: 30

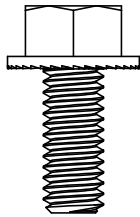

FAS0438
5/16-18 X .75 ZP
HFLNG SCREW
QTY: 16

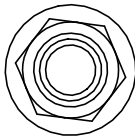

FAS0440
5/16-18 ZP
HFLNG NLK NUT
QTY: 16

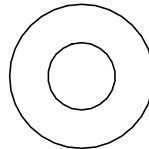

FAS0552
5/16 SST
FLAT WASHER
QTY: 10

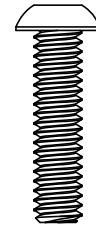

FAS0940
1/4-20 X 1.0 SS NP
BHTX SCREW
QTY: 30

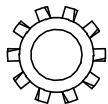

FAS0066
1/4 LOCK WASHER
EXT. TOOTH
QTY: 1

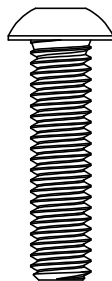

FAS0919
5/16-18 X 1.25 SST
BHC SCREW
QTY: 10

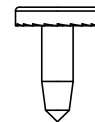

FAS0148
#10 X 0.5 NI-ZN
PH SELF DRILL SCREW
QTY: 1

INTENTIONALLY LEFT BLANK

PAGE:

17

FASTENERS USED

BAG REFERENCE: ALL

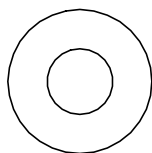

FAS0164
5/16 ALUM
FLAT WASHER
QTY BAG71794: 0
QTY BAG71801: 8

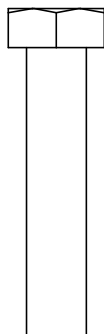

FAS0242
5/16-18 X 1.5 SST
HH SCREW
QTY BAG71794: 8
QTY BAG71801: 8



FAS0248
5/16-18 SST
HH NLK NUT
QTY BAG71794: 8
QTY BAG71801: 8

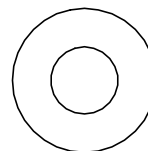

FAS0552
5/16 SST
FLAT WASHER
QTY BAG71794: 16
QTY BAG71801: 8

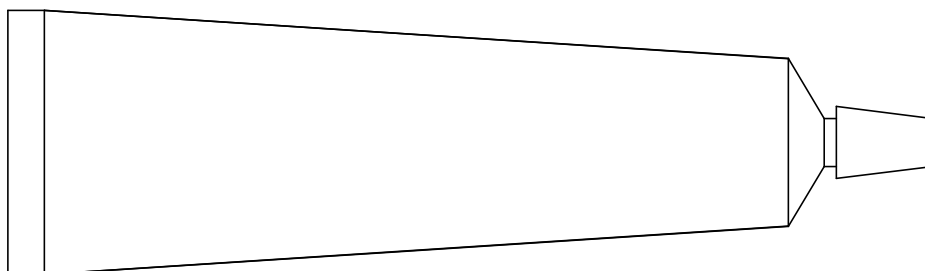

26618-0
1 OZ TUBE
SILICONE
QTY BAG71794: 2
QTY BAG71801: 2

INTENTIONALLY LEFT BLANK

PAGE:

19

FASTENERS USED

BAG REFERENCE: BAG76637



**FAS0917
M5 X .8 ZP
HFLNG NLK NUT
QTY: 12**



**FAS0918
10-24 ZP
HFLNG NLK NUT
QTY: 6**

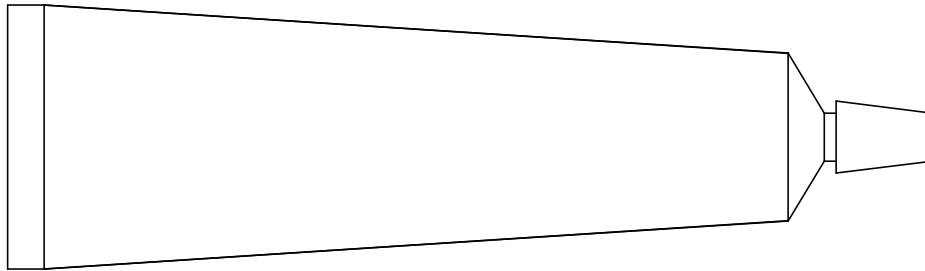

**26618-0
1 OZ TUBE
SILICONE**

INTENTIONALLY LEFT BLANK

STEP 1 - ASSEMBLE BODY FRAME: SIDES AND CROSSBOWS

Step 1.1
OPEN [x2]
TOPPER SIDE
KITS
[TSK78M23W]

Step 1.2
OPEN TOPPER
ROOF KIT
[TRK7823W]

Step 1.3
FULLY TIGHTEN
FAS0438 AND
FAS0440
(16 PLACES)
1/2" WRENCH
1/2" SOCKET

Step 1.4
ADD FOAM
STRIP 80402
TO THE
MIDDLE OF
EACH
CROSSBOW
(4 PLACES)

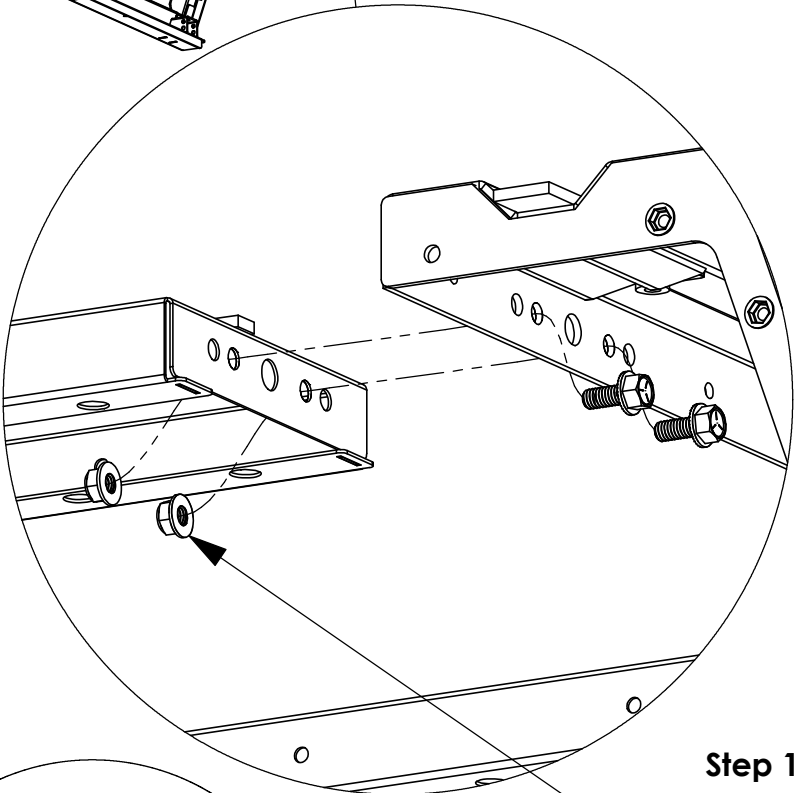
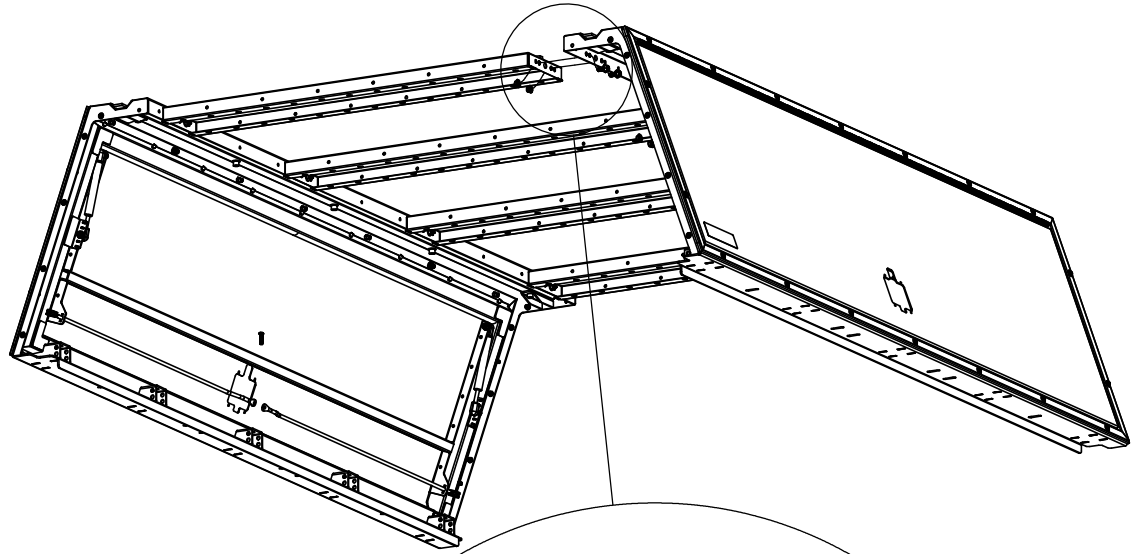

Step 1.3
NOTE: Nut
inboard

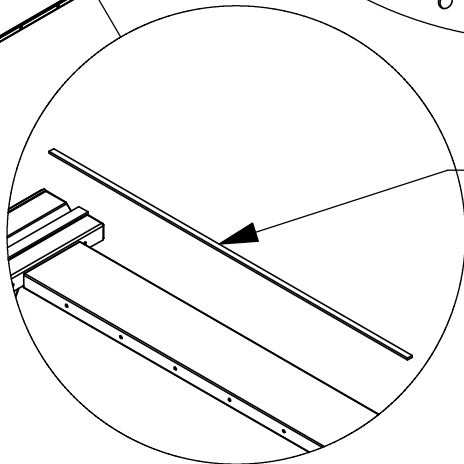
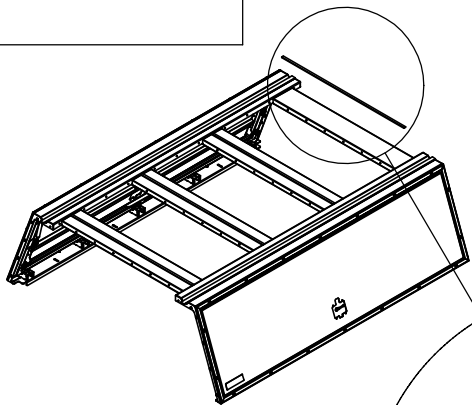

Step 1.4

STEP 2 - ATTACH HARDWARE: SIDE DOOR HANDLES, FRONT & REAR SEALS

Step 2.1
CUT ZIP TIES
THAT ARE
HOLDING
LOCKRODS IN
PLACE.

!! CAUTION !!
DOORS MAY
TRY TO OPEN.

Step 2.2
ATTACH HANDLE
TO DOOR

FULLY TIGHTEN
FAS0917
(4 PER DOOR)
M10 SOCKET

DO NOT
OVERTIGHTEN

Step 2.3
ATTACH
LOCKRODS TO
HANDLE

FULLY TIGHTEN
FAS0918
(2 PLACES)
M8 SOCKET

DO NOT
OVERTIGHTEN

Step 2.4
ADJUST HANDLE
POINT TO ALIGN
WITH CASTING
LINE ON HANDLE
BODY
(APPROX: 1.0")

FULLY TIGHTEN
4mm ALLEN
(2 PLACES)

Step 2.5
APPLY FOAM
SEALS TO ALL
CORNERS.

USE HOLES IN
SEAL TO ALIGN
MATERIAL.

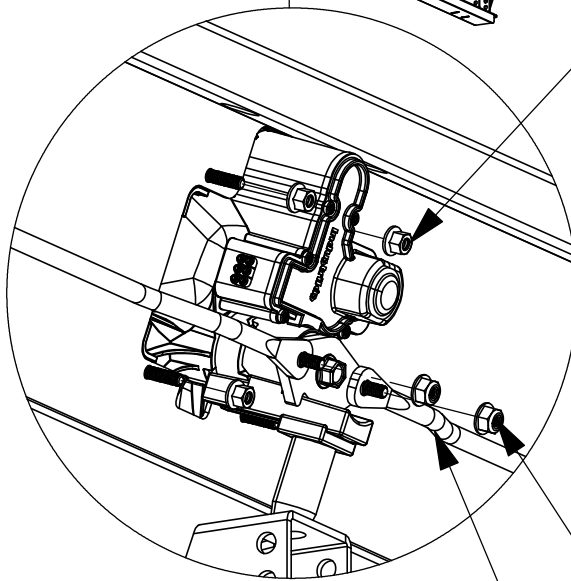
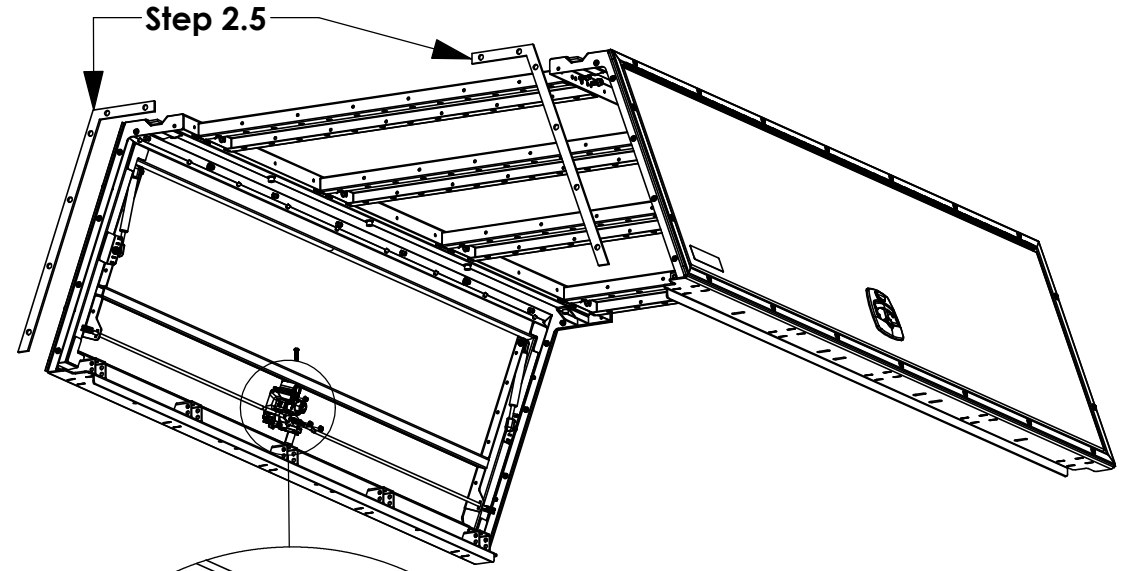

Step 2.2
STOP STEP 2.2 & 2.3
HAVE DIFFERENT
SIZED FASTENERS

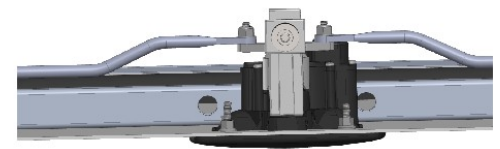

Step 2.3
NOTE THAT ORIENTATION
OF LOCKRODS IS CRITICAL **STOP**



Step 2.1

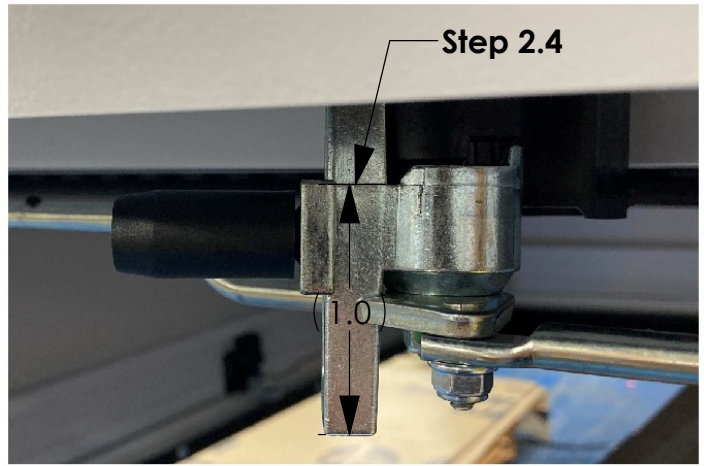

Step 2.4

STEP 3 - ATTACH FRONT PANEL

Step 3.1
OPEN TOPPER
CLOSURE KIT
[TCK78HM23W]

Step 3.2
ATTACH FRONT
PANEL

HAND TIGHTEN
FAS0234,
FAS0940
(10 PLACES)

DO NOT
TIGHTEN UNTIL
AFTER STEP 4

Step 3.2B
COLORADO
FRONT PANEL
FLANGE IS
OUTBOARD

DO NOT
TIGHTEN UNTIL
AFTER STEP 4

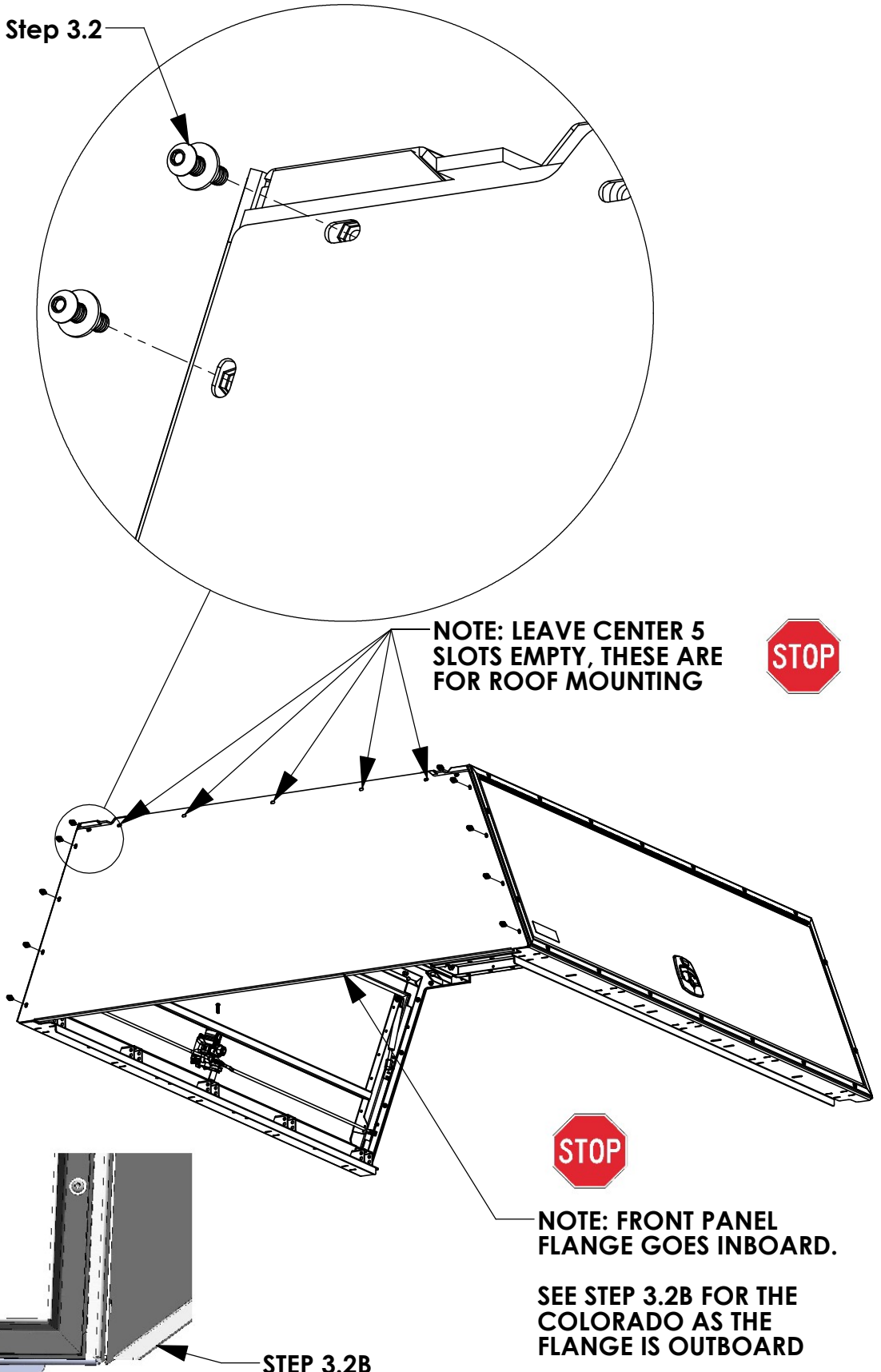

NOTE: LEAVE CENTER 5
SLOTS EMPTY, THESE ARE
FOR ROOF MOUNTING



NOTE: FRONT PANEL
FLANGE GOES INBOARD.

SEE STEP 3.2B FOR THE
COLORADO AS THE
FLANGE IS OUTBOARD

STEP 3.2B

STEP 4 - ATTACH LIFTGATE

**Step 4.1
ATTACH
LIFTGATE FRAME**

**FULLY TIGHTEN
FAS0234,
FAS0940
(10 PLACES)
5/32" ALLEN**

**Step 4.2
GO BACK AND
FULLY TIGHTEN
FASTENERS
FROM STEP 3.2**

**(10 PLACES)
5/32" ALLEN**

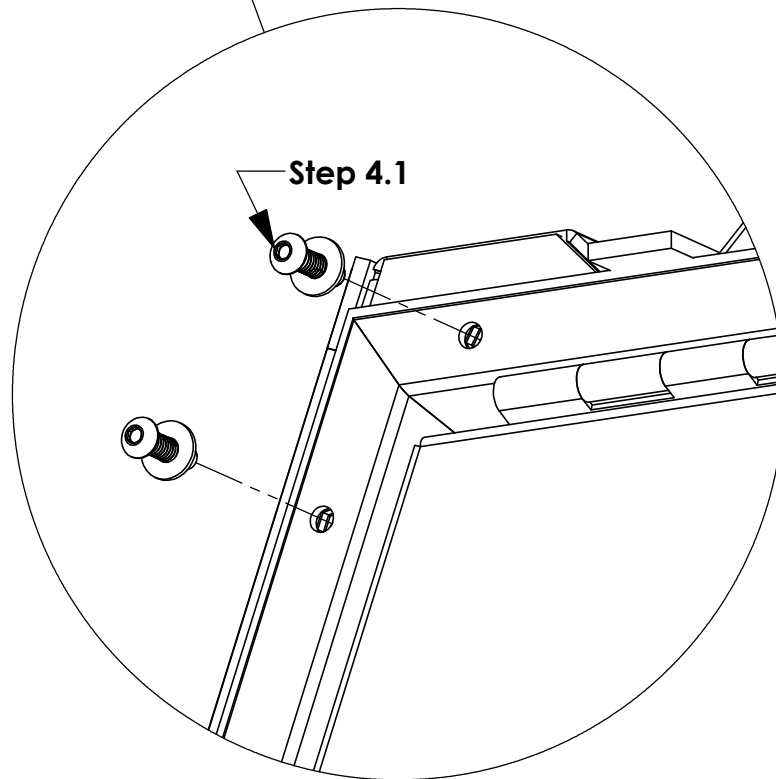
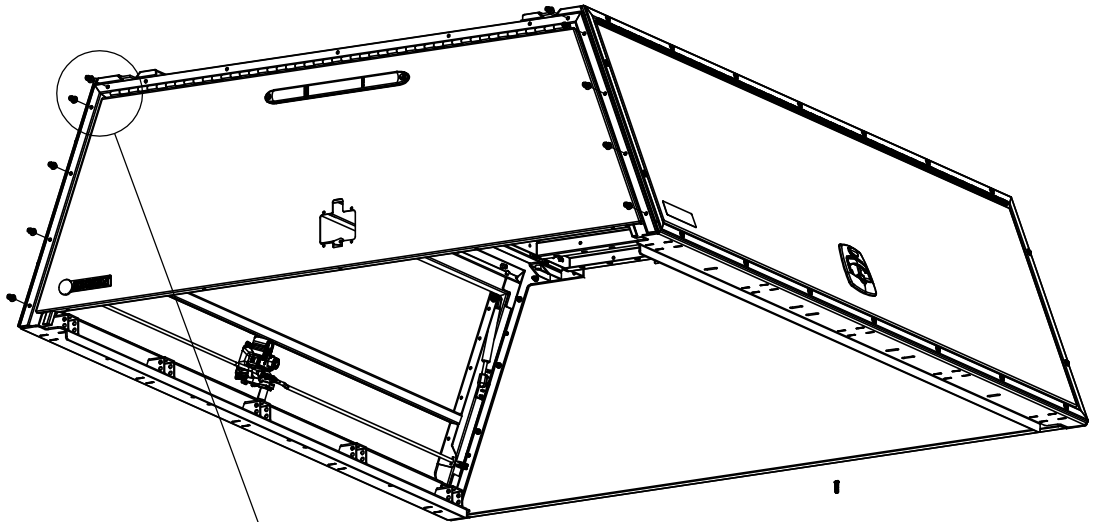

STEP 5 - ATTACH LIFTGATE HANDLE

Step 5.1
CUT ZIP TIES
THAT ARE
HOLDING
LOCKRODS IN
PLACE.

!! CAUTION !!
DOOR MAY TRY
TO OPEN.



STEP 5.1

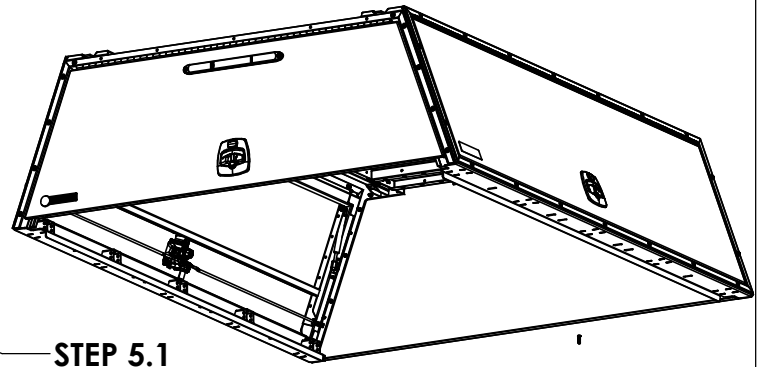

Step 5.2
ATTACH HANDLE
TO DOOR

FULLY TIGHTEN
FAS0917
(4 PER DOOR)
M10 SOCKET

DO NOT
OVERTIGHTEN

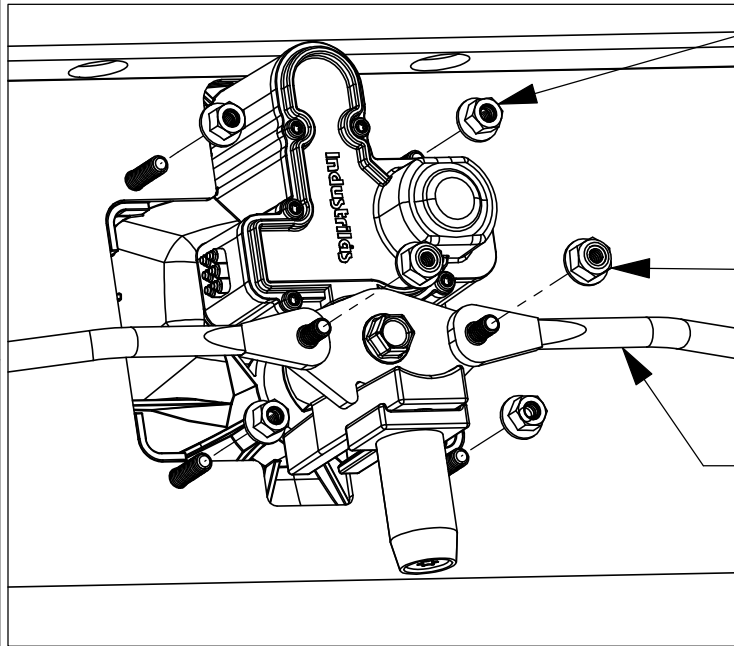

STEP 5.2



STEP 5.2 & 5.3
HAVE DIFFERENT
SIZED FASTENERS

STEP 5.3

Step 5.3
ATTACH
LOCKRODS TO
HANDLE

FULLY TIGHTEN
FAS0918
(2 PLACES)
M8 SOCKET

DO NOT
OVERTIGHTEN

NOTE THAT ORIENTATION
OF LOCKRODS IS
CRITICAL



Step 5.4
ADJUST HANDLE
POINT TO ALIGN
WITH CASTING
LINE ON HANDLE
BODY
(APPROX: 1.0")

FULLY TIGHTEN
M4 ALLEN
(2 PLACES)

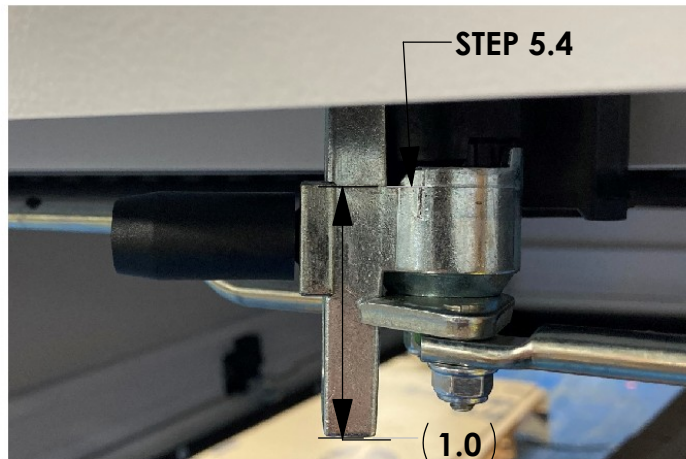

STEP 5.4

(1.0)

STEP 6 - ATTACH ROOF AND ROOF RAILS

Step 6.1
SET ROOF PANEL
ON TOPPER BODY



PLEASE NOTE THAT ORDER OF OPERATIONS ON THESE BUILD STEPS IS CRITICAL TO A PROPER SEAL!

Step 6.2
ATTACH
MOUNTING RAILS
TO TOPPER BODY.

USE AN
ALIGNMENT
PUNCH TO POKE
THROUGH SEALS

FULLY TIGHTEN
FAS0552,
FAS0919
(10 PLACES)
3/16" ALLEN

Step 6.3
ATTACH ROOF
TO TOPPER
BODY.

FULLY TIGHTEN
FAS0055,
FAS0552,
FAS0940
(10 PLACES)
5/32" ALLEN
7/16" WRENCH

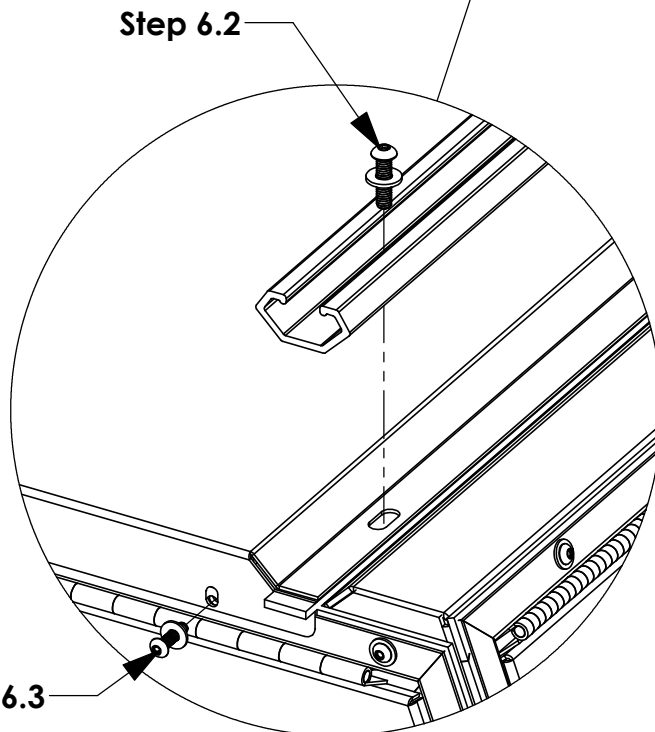
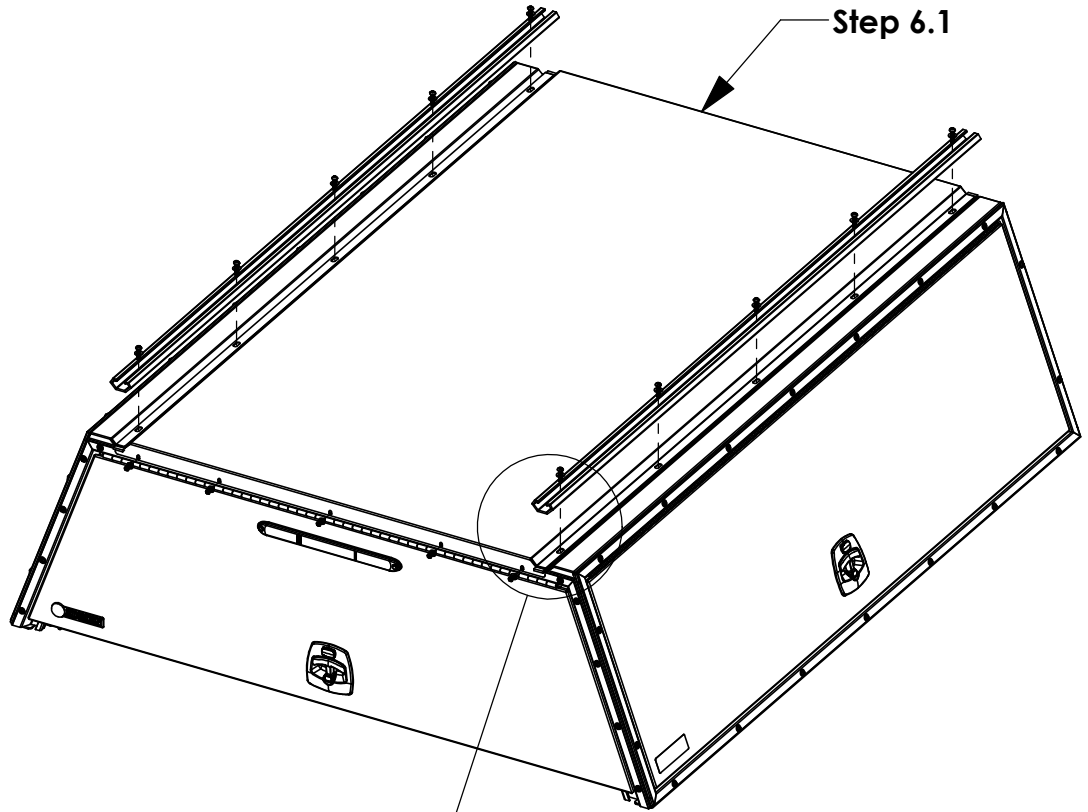

STEP 7 - ATTACH TAILGATE COVER

Step 7.1
ADD SILICONE TO
CORNER OF
TAILGATE COVER
AND AROUND
BOTTOM FACE
MOUNTING
HOLES.

Step 7.1
FULL LENGTH
OF THIS SEAM

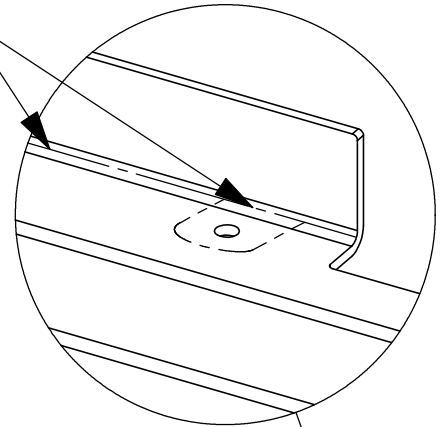

Step 7.2
ATTACH TAILGATE
COVER TO REAR
DOOR.

NOTE: INSTALL
CENTER BOLT FIRST
TO HOLD IN PLACE
DURING INSTALL

FULLY TIGHTEN
FAS0062,
FAS0067,
FAS0055
(9 PLACES)

#2 PHILLIPS
7/16" SOCKET
7/16" WRENCH

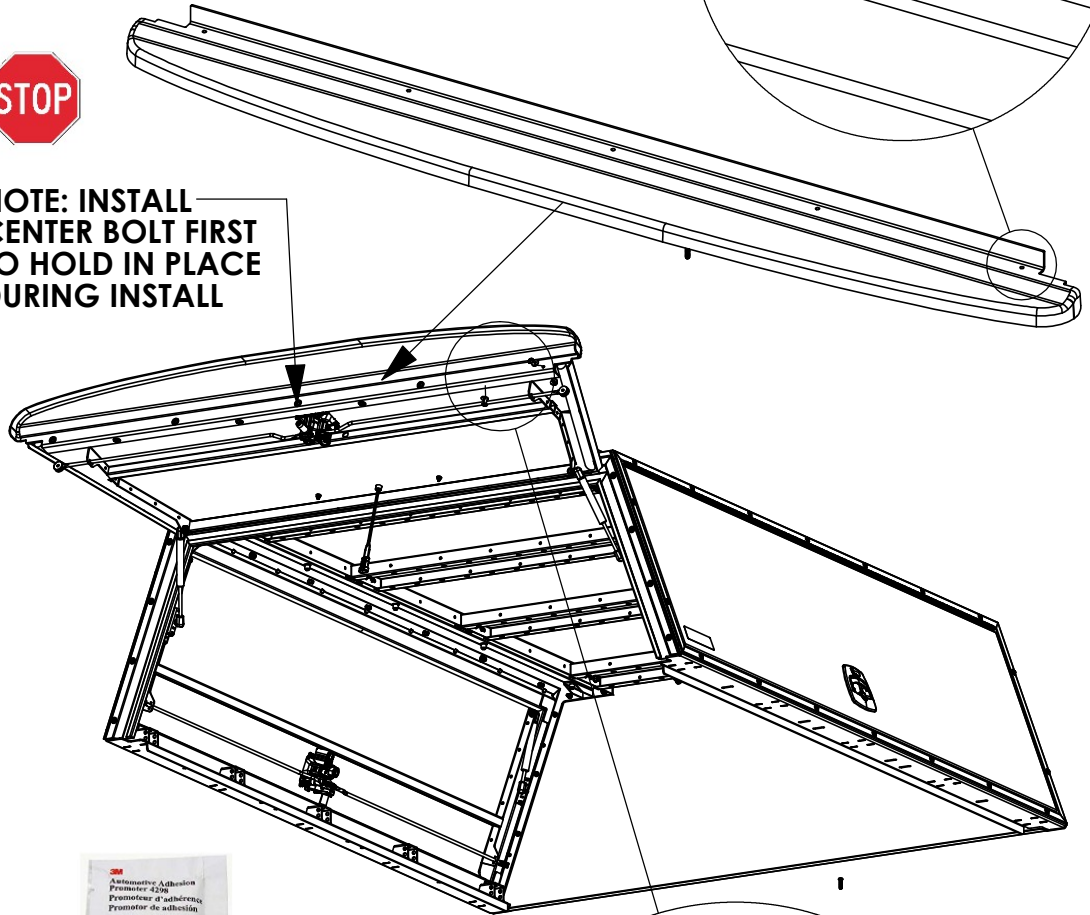

Step 7.3
COLORADO &
SILVERADO.
PREP WITH 57392
ADHESION
PROMOTER.

ADD 77152
D-SEAL X 22" LG
TO BOTH SIDE OF
TAILGATE COVER



Step 7.3
COLORADO &
SILVERADO

Step 7.2

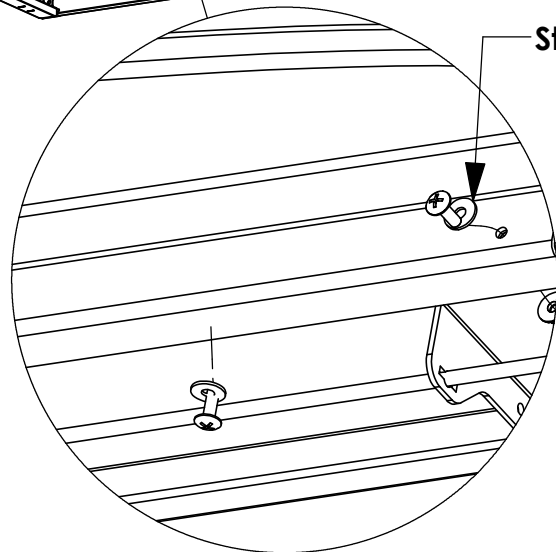

STEP 8 - ATTACH SEALS TO TRUCK BED

Step 8.1
INSTALL FRONT
BED SEAL. REFER
TO TABLE 1 TO
GET OEM
SPECIFIC
DISTANCE OFF
OF THE INSIDE
EDGE OF THE
BED. CENTER
BETWEEN THE
DRIVER AND
PASSENGER SIDE
BED RAIL TRIM.

TRIM OFF EXTRA,
IF NECESSARY.

TOP VIEW - COLORADO, SILVERADO
& RAM, FULL DISTANCE AT FRONT
EDGE

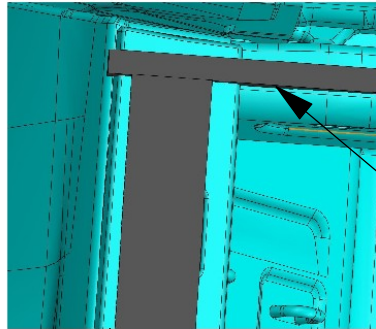

STEP 8.3
AT FLAT

Step 8.1
DIST

STEP 8.3
1/4" GAP

TOP VIEW

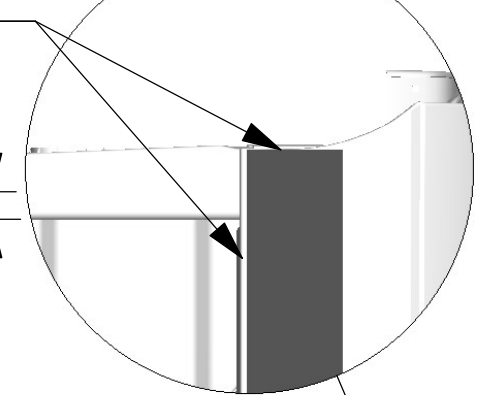

Step 8.2
INSTALL SIDE BED
SEALS. ALIGN TO
THE FRONT AND
INSIDE EDGES OF
THE SIDE BED
RAIL TRIM.

DO NOT TRIM
EXCESS UNTIL
TOPPER IS ON
THE TRUCK.

Step 8.3
COLORADO
ONLY !
INSTALL SIDE BED
SEALS. ALIGN TO
THE FRONT AND
INSIDE EDGES OF
THE SIDE BED
RAIL TRIM.

DO NOT TRIM
EXCESS UNTIL
TOPPER IS ON
THE TRUCK.

DRIVER'S
SIDE

FRONT

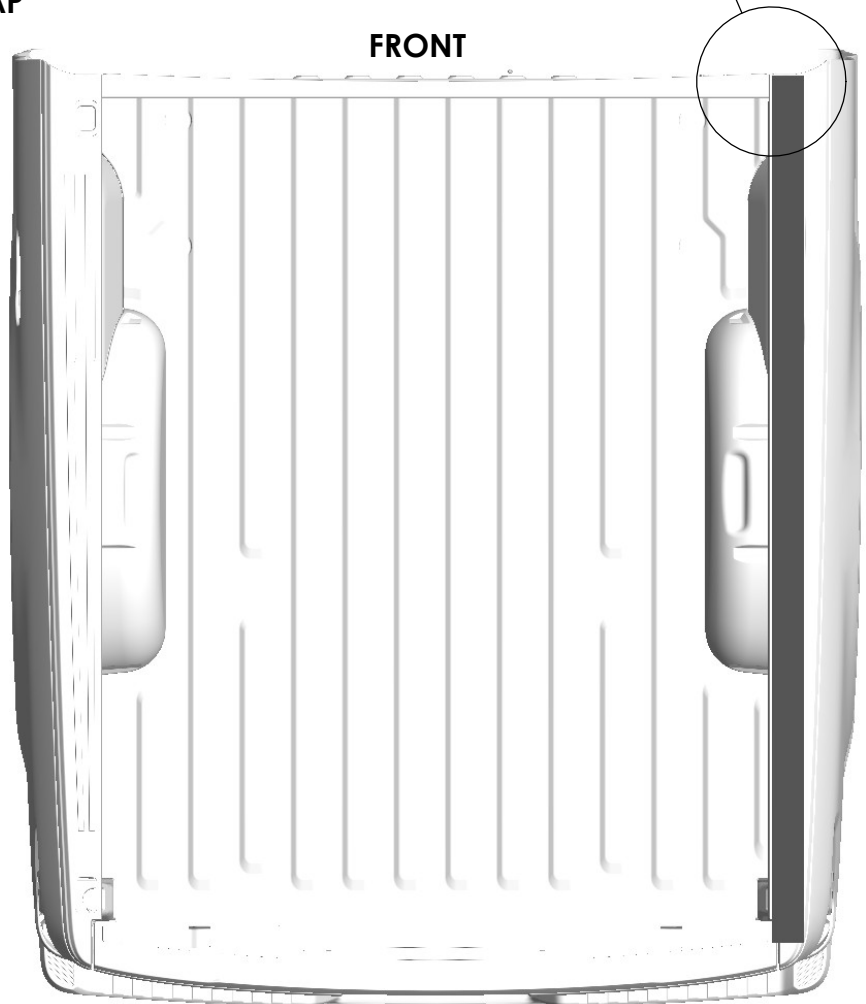

TABLE 1:

VEHICLE PLATFORM	DIST.
F-150	.875"
SILVERADO	0.25"
RAM	.15"

STEP 8 - ATTACH SEALS TO TRUCK BED (NOTE: FOR CHEVY SILVERADO ONLY)

Step 8.4
PLACE 81456 GASKET IN THE GAP BETWEEN THE TRUCK BED AND CAB.



BEFORE ATTACHING TO TRUCK BED, CLEAN AND PREP AREA. DO NOT ATTACH TO PLASTIC TRIM. IF TRIM IS ON FRONT OF BED ATTACH TO CAB.

ONCE AREA IS PREPARED CENTER GASKET ON THE REAR WINDOW.

MAKE SURE THAT GASKET HAS FULL SURFACE CONTACT SO ADHESIVE WILL PROPERLY BOND.



Step 8.4

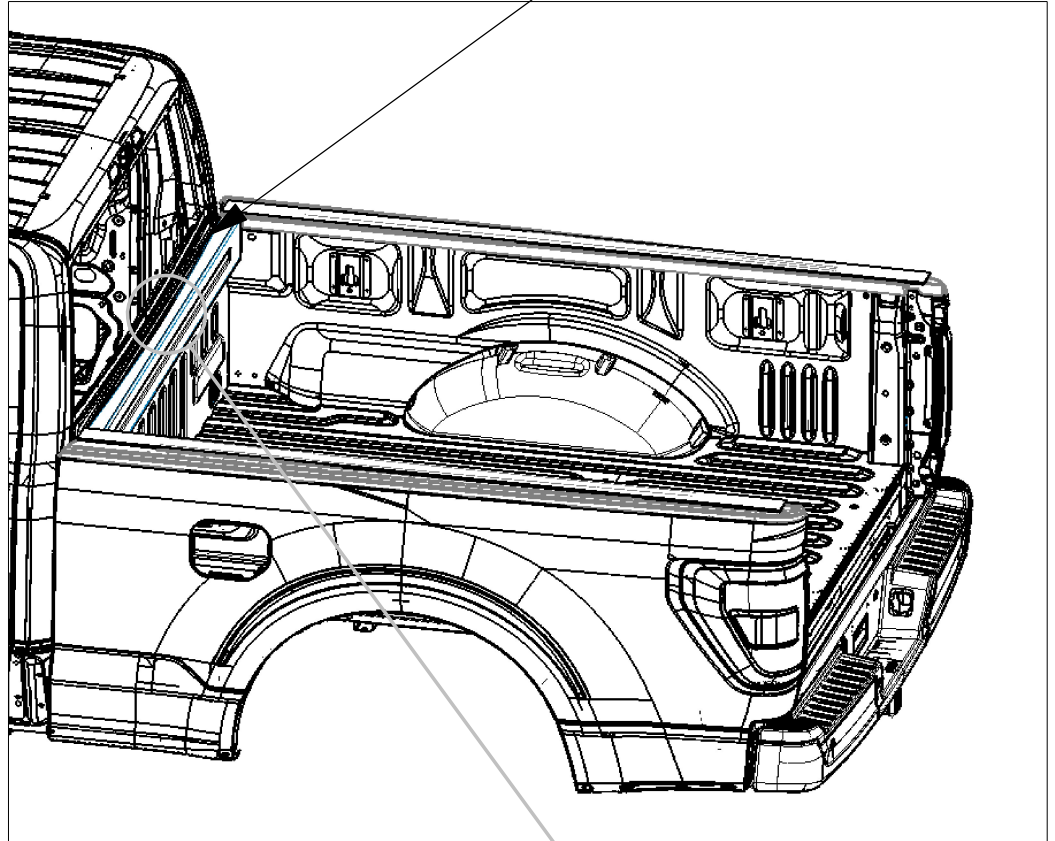

NOTE:
IF TRUCK BED HAS A SPRAY ON BED LINER, PLACE GASKET UNDER LINER ON TRUCK BED

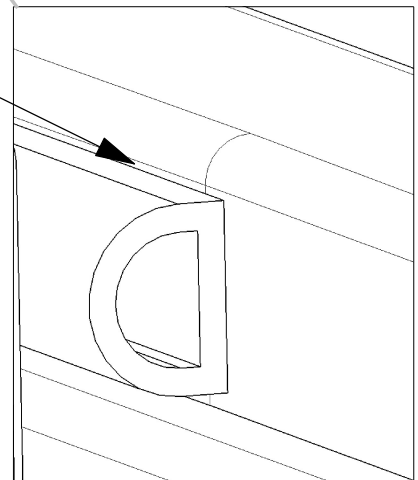

STEP 9A - INSTALL FOAM & 73740 SEALANT TO TRUCK CAB AND BED SEAMS (NOTE: FOR CHEVY SILVERADO ONLY)

STEP 9A.1
CUT A 2.5" FOAM PIECE OF 73398, INSERT UNDER TRIM OF THE BED RAIL, GOING INTO THE GAP AS SHOWN

STEP 9A.1

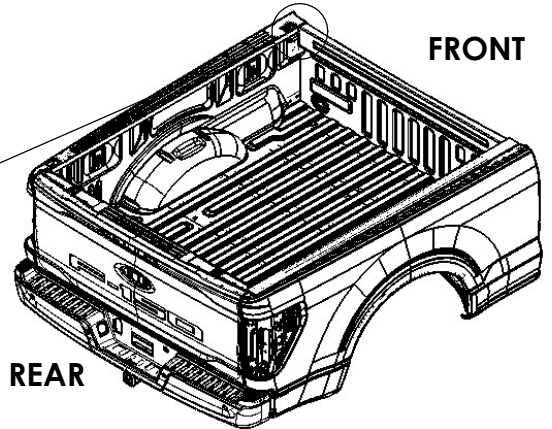
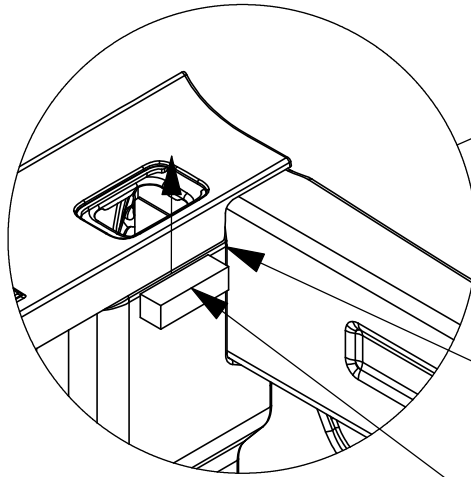

THERE IS A GAP BETWEEN THE OEM BED AND TRIM (NOT SHOWN)

INSERT THE FOAM UNDER THE TRIM AND COVER THE GAP W/ THE FOAM

STEP 9A.2
INSERT A 2ND FOAM OF THE SAME DIMENSION INTO THE GAP, PERPENDICULAR TO THE ONE IN STEP 9.1, BOTH PIECES SHOULD BE TOUCHING

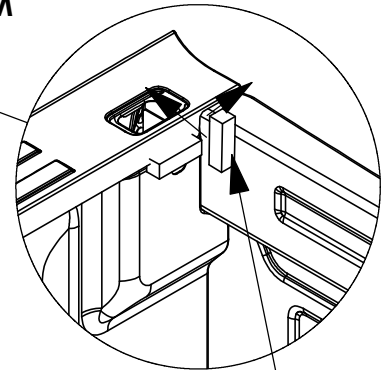
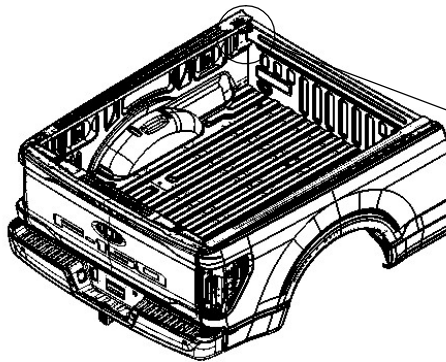

STEP 9A.2

INSERT THE 2ND PIECE OF FOAM PERPENDICULAR TO THE 1ST PIECE. FOLD OVER THE FOAM TO ALSO COVER THE GAP BETWEEN THE TRIM AND WALL RAIL

STEP 9A.3
SECURE BOTH PIECES OF FOAM IN PLACE WITH 3M SEALANT AROUND THE PERIMETER AND FILL ANY REMAINING GAPS, REPEAT ON PASSENGER SIDE



STEP 9A.3

ADD 3M SEALANT AROUND THE PERIMETER OF THE FOAMS, BETWEEN THE RAIL TRIM & THE BED, & REPEAT ON PASSENGER SIDE

STEP 9B - INSTALL FOAM TO TRUCK CAB AND BED SEAMS (NOTE: FOR CHEVY SILVERADO EV ONLY)

STEP 9B.1
PLACE FOAM
AROUND TOP
OF BED RAILS,
STRIPS WILL
BUTT UP
AGAINST EACH
OTHER AT
CORNERS

STEP 9B.1

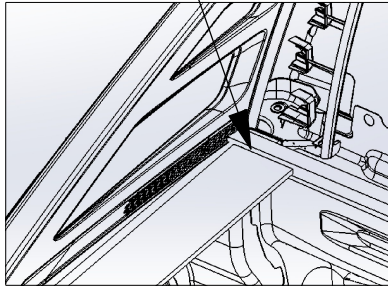

71766

FRONT

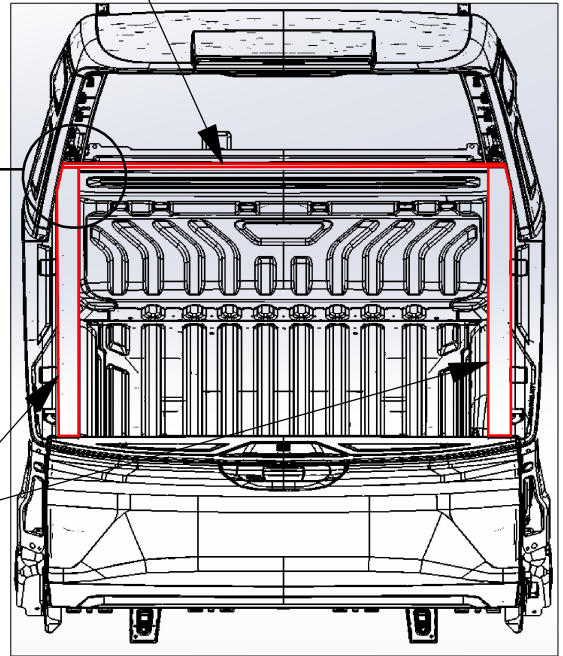

71768

REAR

STEP 9B.2
WHEN PLACING
TOPPER ON BED,
TOPPER WILL
NEED TO BE
BROUGHT IN
LOW AND THEN
MOVED
FORWARD TO FIT
INSIDE TRUCK
TRIM. (AS
SHOWN)

NOTE:
LOCATE DRAIN HOLES AND
TRIM FOAM AROUND THEM,
TO MAKE SURE HOLES AREN'T
BEING BLOCKED

STEP 9B.2

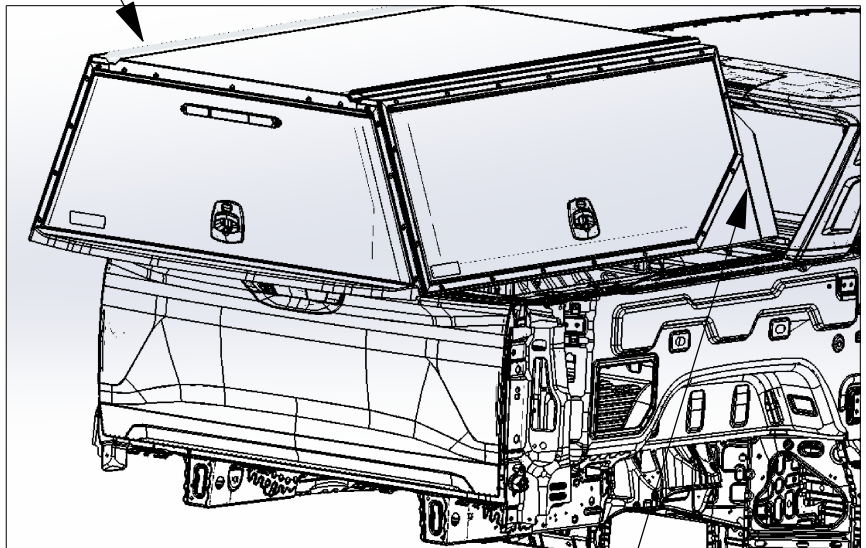

STEP 9B.3
WITH TOPPER IN
PLACE EXCESS
TRIM

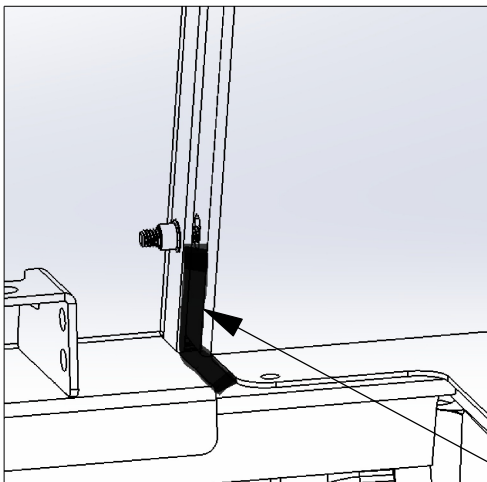

NOTE:
WHEN TOPPER IS IN PLACE USE
SLICONE INSIDE OF TOPPER TO
SEAL GAPS AT FRONT OF TOPPER .
(AS SHOWN)

STEP 9C - INSTALL FOAM, (6) SPACER & 73740 SEALANT TO TRUCK CAB AND BED SEAMS (NOTE: FOR FORD RANGER ONLY)

STEP 9C.1
REMOVE PLUGS
LOCATED ON
THE TRUCK BED
RAIL,



**DO NOT DRILL
INTO THE RAIL**

STEP 9C.2
CENTER
(6) SPACERS
OVER HOLE,
TAPE SPACER TO
HOLD IT IN THE
LOCATION

NOTE:
TALL SPACERS
TO BE USED
WITH 2025
MODELS,

**SHORT SPACERS
TO BUT USED
WITH 2026 OR
NEWER MODELS**

STEP 9C.3
PLACE FOAM
AROUND TOP OF
BED RAILS, STRIPS
WILL BUTT UP
AGAINST EACH
OTHER AT
CORNERS

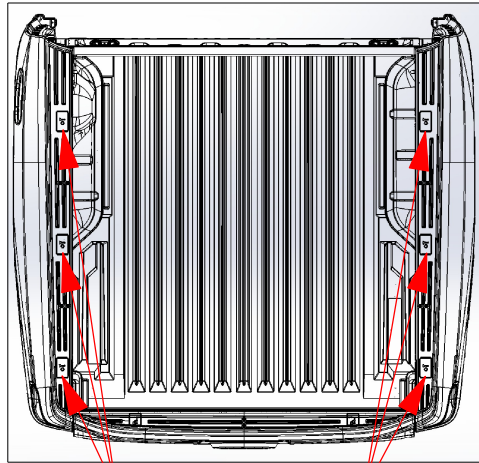

STEP 9C.1

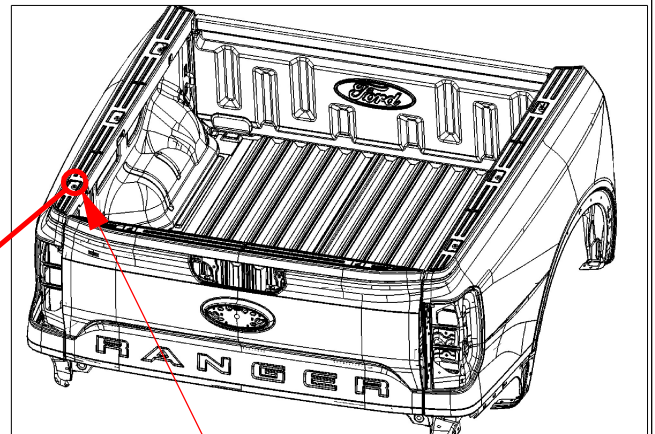
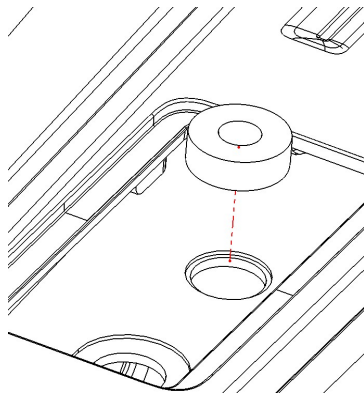

STEP 9C.2

STEP 9C.3

71766

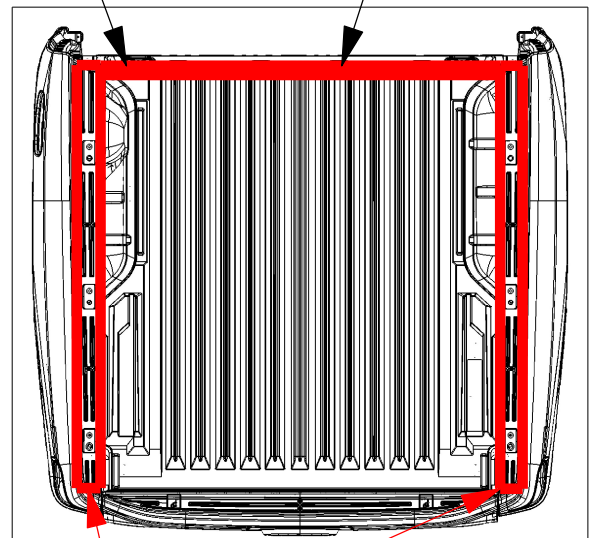

71768



NOTE:
BEFORE INSTALL PREP IS STARTED,
IF RANGER MODEL YEAR IS 2024, MAKE SURE
THAT LOAD BOX REINFORCEMENT BRACKETS
HAVE BEEN INSTALLED. SCAN QR CODE FOR
DOCUMENTED DIRECTION



STEP 9C - INSTALL FOAM, (6) SPACER & 73740 SEALANT TO TRUCK CAB AND BED SEAMS (NOTE: FOR FORD RANGER ONLY)

STEP 9C.4
SLIDE 80670 & 80671 UNDER TRIM AT FRONT CORNERS OF BED TO MOUNT TO OEM HOLES, FULLY TIGHTEN (6)FAS0329, (6)FAS0552, & (6)FAS0588

M8 SOCKET DRILL

NOTE:
TRIM IS NOT VISIBLE FOR CLARITY

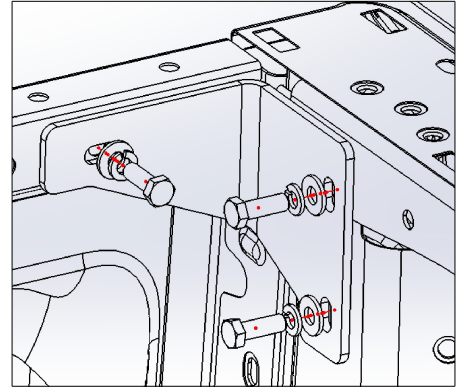

STEP 9C.4

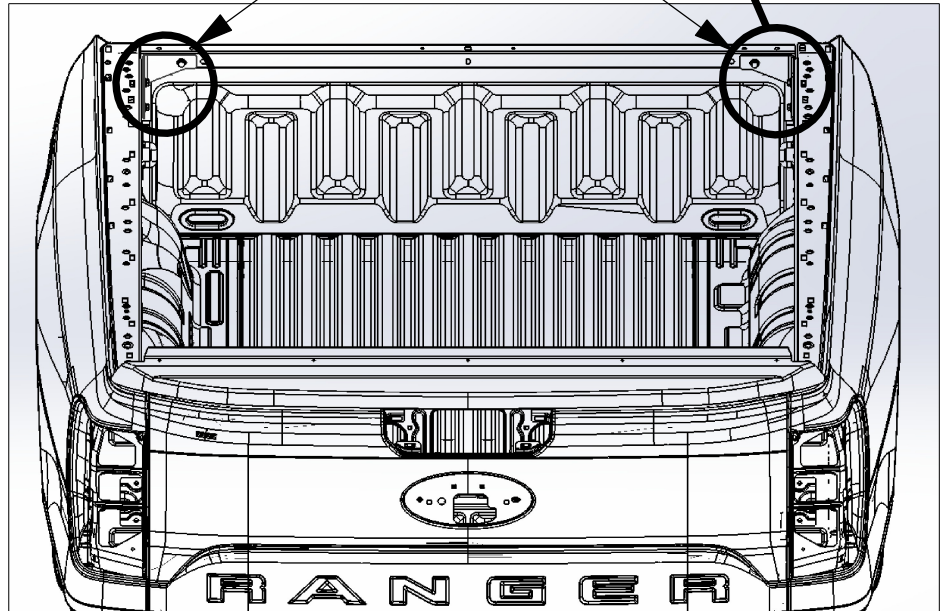

NOTE:
BEFORE INSTALL PREP IS STARTED, IF RANGER MODEL YEAR IS 2024, MAKE SURE THAT LOAD BOX REINFORCEMENT BRACKETS HAVE BEEN INSTALLED. SCAN QR CODE FOR DOCUMENTED DIRECTION



STEP 10 - ATTACH TOPPER TO TRUCK BED



NOTE: (FOR 8.0' 26" TALL RAM 1500, 2500, 3500 ONLY) TOPPER MUST BE SOFT INSTALLED TO MARK FOR DRILLING. TOPPER TO BE REMOVED PRIOR TO DRILLING.

**Step 10.1
SET TOPPER ONTO TRUCK BED. ALIGNMENT IS BASED OFF OF THE TAILGATE CLEARANCE CUTOUT IN THE SIDE BED RAILS (FOR FORD ONLY) AND PLACE ON THE PREVIOUSLY INSTALLED FRONT BED SEAL STEP 8.1**

THESE 2 FACES SHOULD BE ALIGNED.

**Step 10.2
USE HOLES IN THE BED RAIL TO MARK AND DRILL MOUNTING LOCATIONS. IT IS NOT NECESSARY TO REMOVE THE TOPPER FOR THIS STEP.**

**(8 PLACES)
1 1/32" DRILL BIT**



NOTE: IF THESE HOLES INTERFERE WITH THE OEM BODY, DRILL A NEW HOLE IN THE BED RAIL +/- 2" FROM THE INTERFERENCE.

NOTE: IT IS RECOMMENDED THAT YOU LOAD THE TOPPER ONTO A TRUCKBED WITH ONE OF THE FOLLOWING METHODS:

- HOIST: ATTACH TO THE ROOF RAILS OF THE TOPPER
- FORKLIFT: OPEN THE REAR DOOR AND SET FORKS ON THE ROOF BOWS
- MANUAL: HAVE 1 INDIVIDUAL AT EACH CORNER OF THE TOP AND CARRY OVER THE SIDES OF THE TRUCK. DO NOT SCRATCH THE VEHICLE.

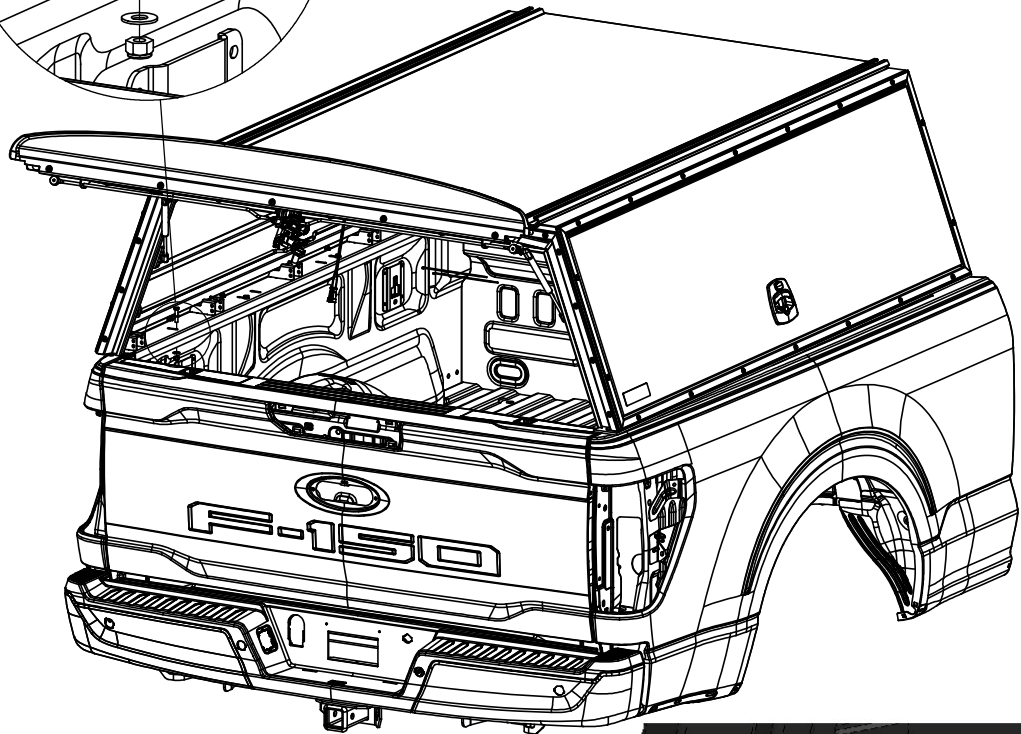
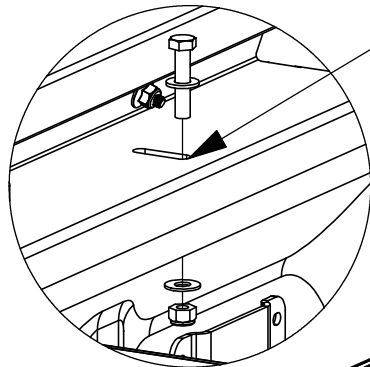

Step 10.1

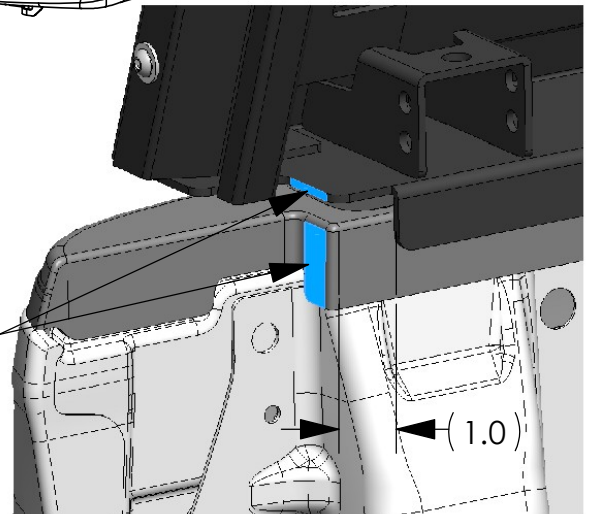

STEP 10 ALT- ATTACH TOPPER TO TRUCK BED



NOTE: (FOR 5.0' FORD RANGER ONLY) TOPPER MUST BE SOFT INSTALLED TO MARK FOR DRILLING. TOPPER TO BE REMOVED PRIOR TO DRILLING.

Step 10.1 ALT
SET TOPPER ONTO TRUCK BED. ALIGNMENT IS BASED OFF OF THE TAILGATE CLEARANCE CUTOUT IN THE SIDE BED RAILS (FOR FORD ONLY) AND PLACE ON THE PREVIOUSLY INSTALLED FRONT BED SEAL STEP 8.1

THESE 2 FACES SHOULD BE ALIGNED.

NOTE: IT IS RECOMMENDED THAT YOU LOAD THE TOPPER ONTO A TRUCKBED WITH ONE OF THE FOLLOWING METHODS:

- HOIST: ATTACH TO THE ROOF RAILS OF THE TOPPER
- FORKLIFT: OPEN THE REAR DOOR AND SET FORKS ON THE ROOF BOWS
- MANUAL: HAVE 1 INDIVIDUAL AT EACH CORNER OF THE TOP AND CARRY OVER THE SIDES OF THE TRUCK. DO NOT SCRATCH THE VEHICLE.

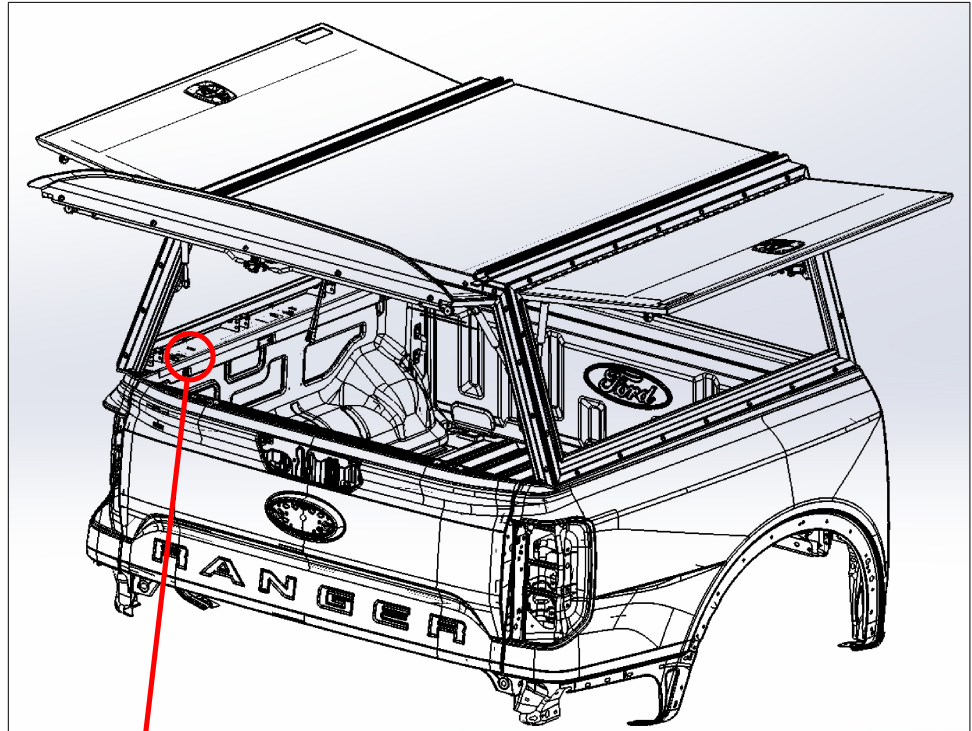

Step 10.2 ALT
USE HOLES IN THE BED RAIL TO MARK AND DRILL MOUNTING LOCATIONS. IT IS NOT NECESSARY TO REMOVE THE TOPPER FOR THIS STEP.

(8 PLACES)
11/32" DRILL BIT



NOTE: IF THESE HOLES INTERFERE WITH THE OEM BODY, DRILL A NEW HOLE IN THE BED RAIL +/- 2" FROM THE INTERFERENCE.

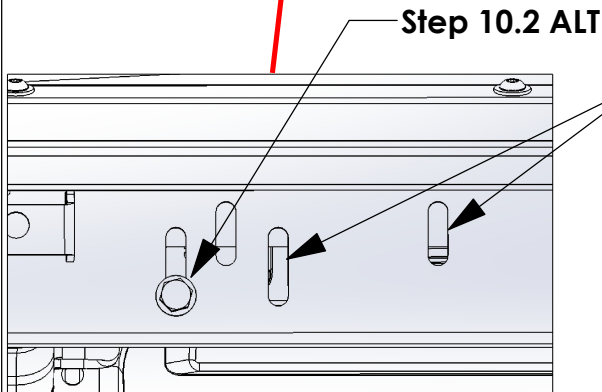

NOTE: OVERHEAD VIEW FOR CLARITY

NOTE: OUTER SLOTS ARE TO BE USED WITH 2026 FORD RANGER INNER AND SMALLER SLOTS TO BE USED WITH 2025 FORD RANGER

Step 10.1

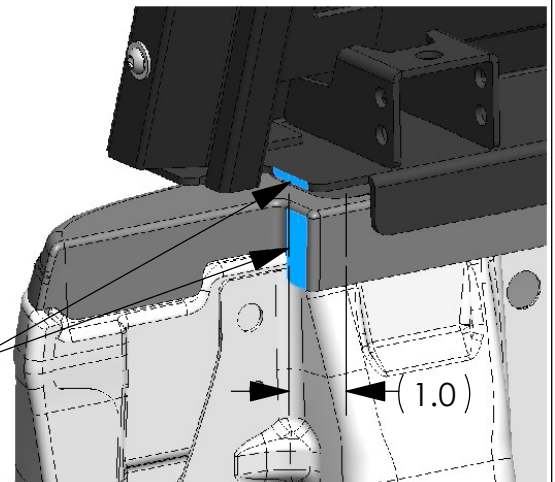

STEP 10 - ATTACH TOPPER TO TRUCK BED



NOTE: (FOR 8.0' 26" TALL RAM 1500, 2500, 3500 ONLY) TOPPER MUST BE SOFT INSTALLED TO MARK FOR DRILLING. TOPPER TO BE REMOVED PRIOR TO DRILLING.

Step 10.3
USING THE HOLES YOU JUST DRILLED OUT, FASTEN THE TOPPER TO THE TRUCK BED.
FAS0242,
FAS0552 [x2],
FAS0248

(8 PLACES)
1/2" SOCKET
1/2" WRENCH

Step 10.4
ADD TO BOTH SIDES SILICONE BETWEEN FRONT PANEL GAP AND BED RAIL, AND REAR OF TOPPER.

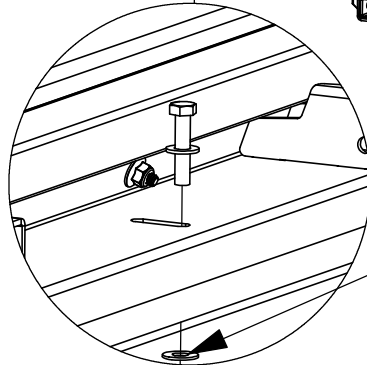
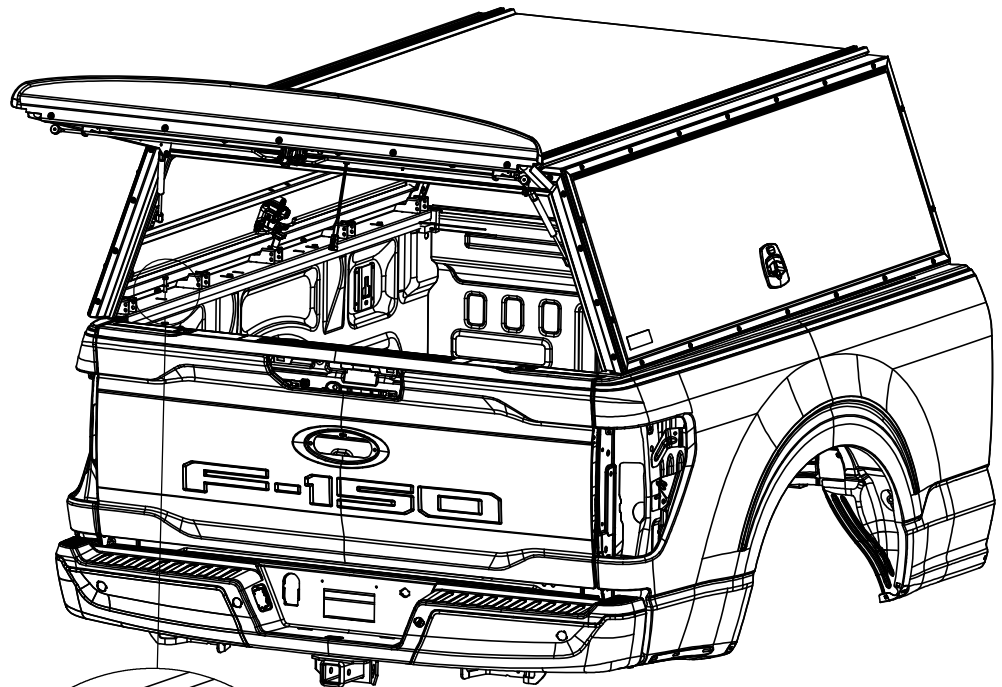

Step 10.3

FRONT

REAR

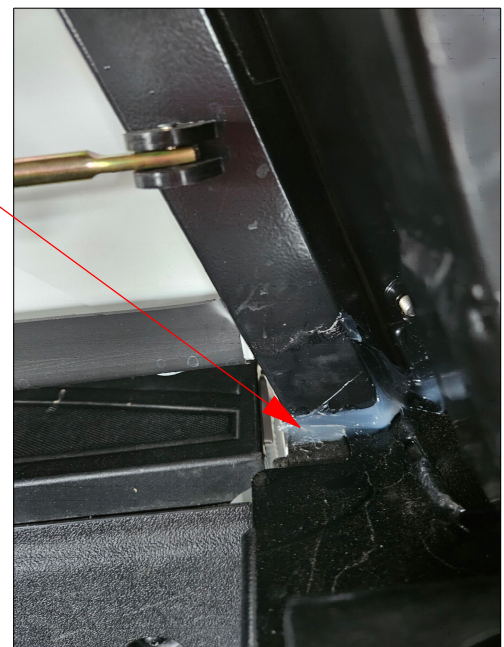

Step 10.4

MAKE SURE ALL FASTENERS ARE TIGHTENED!! INSTALLATION IS COMPLETE

STEP 10 (CON'T) - ATTACH TOPPER TO TRUCK BED



NOTE: (FOR 8.0' 26" TALL RAM 1500, 2500, 3500 ONLY) TOPPER MUST BE SOFT INSTALLED TO MARK FOR DRILLING. TOPPER TO BE REMOVED PRIOR TO DRILLING.

Step 10.4
COLORADO
TOPPER.
ALIGNMENT IS
BASED OFF OF
THE TAILGATE
AND THE SIDE BED
RAILS.

THESE 2 FACES
SHOULD BE
ALIGNED.

Step 10.5
USING THE HOLES
YOU JUST DRILLED
OUT, FASTEN THE
TOPPER TO THE
TRUCK BED.
FAS0242,
FAS0552 [x2],
FAS0248

(6 PLACES)
1/2" SOCKET
1/2" WRENCH

NOTE: IT IS RECOMMENDED THAT YOU LOAD THE TOPPER ONTO A TRUCKBED WITH ONE OF THE FOLLOWING METHODS:

- HOIST: ATTACH TO THE ROOF RAILS OF THE TOPPER
- FORKLIFT: OPEN THE REAR DOOR AND SET FORKS ON THE ROOF BOWS
- MANUAL: HAVE 1 INDIVIDUAL AT EACH CORNER OF THE TOP AND CARRY OVER THE SIDES OF THE TRUCK. DO NOT SCRATCH THE VEHICLE.

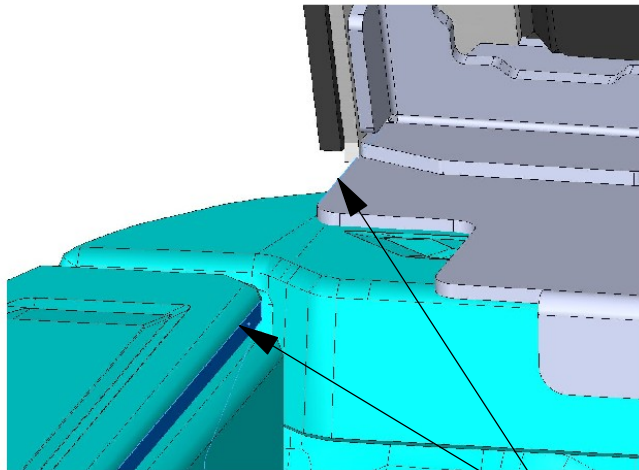

Step 10.4
IN LINE

STEP 10.5
INSIDE SLOTS FOR
THE COLORADO

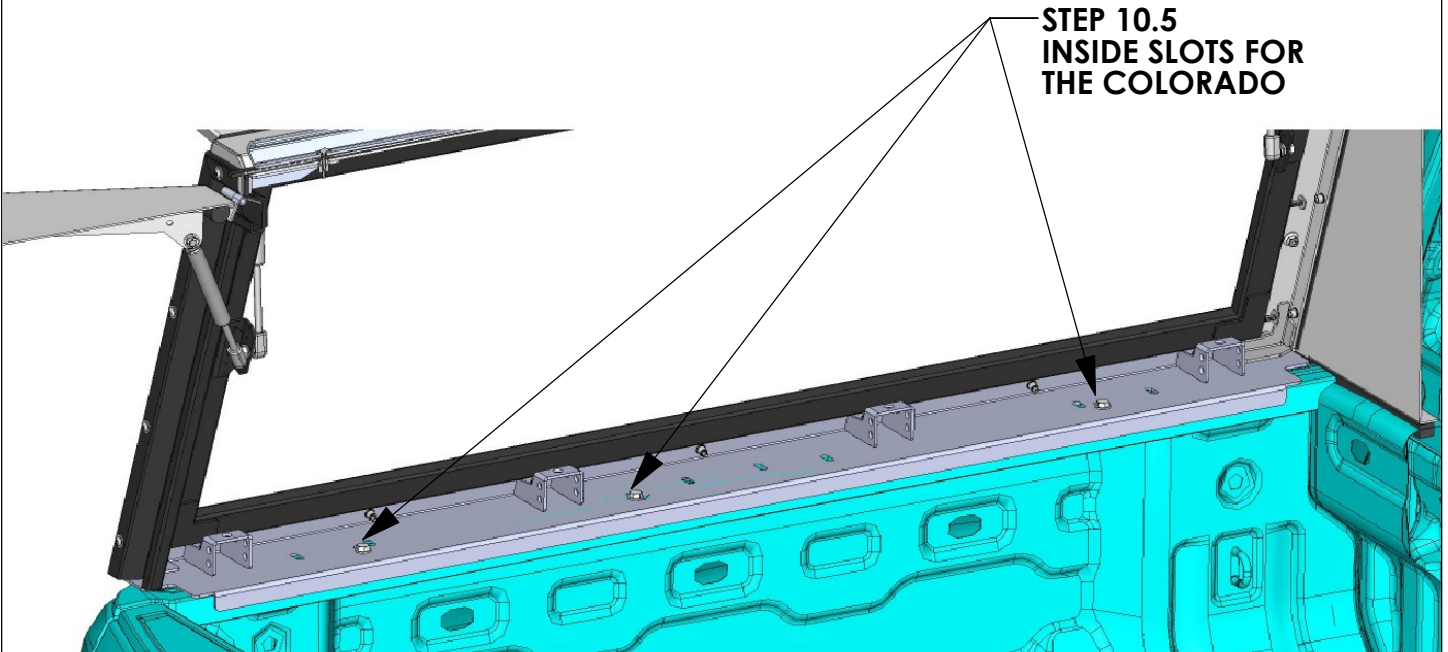

MAKE SURE ALL FASTENERS ARE TIGHTENED!! INSTALLATION IS COMPLETE

Introduction / Comments:

Install Instructions For Brake Light On Topper For F150 (5.5'/6.5' & 8')

Note:

Read all instructions prior to installation. Review the Adrian Steel **GENERAL PRECAUTIONS PAGES (56638)** before attempting installation. Only personnel familiar with using electrical best practices should perform this install. Reference **ELECTRICAL BEST PRACTICES MANUAL (54479)** before attempting installation.

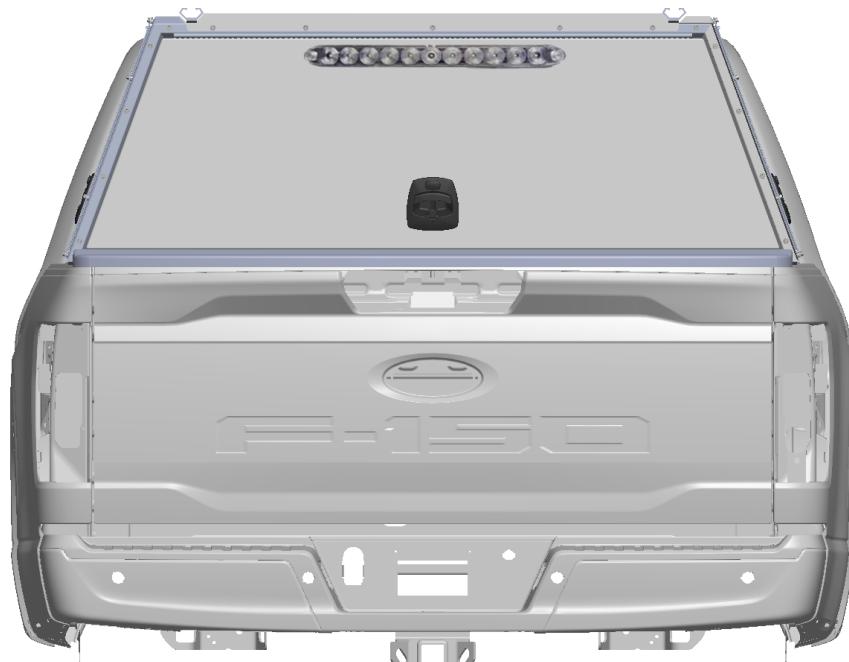

**Installation Instructions For Brake Light On
Topper For F150 (5.5'/6.5' & 8')**

Routing Overview

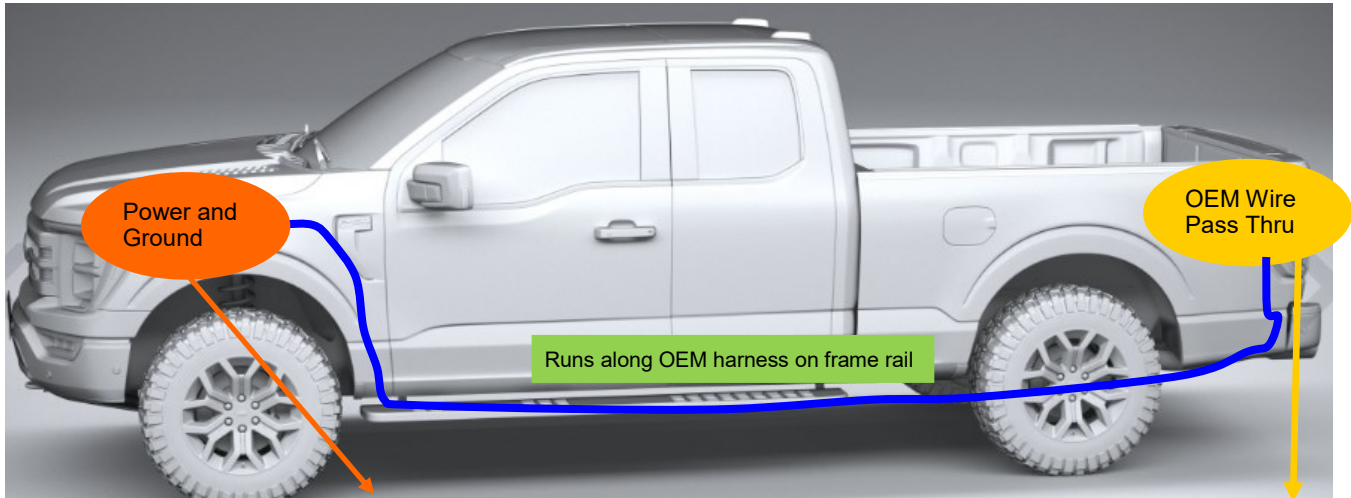

Color	Key - Items
Orange	Power and Ground Location
Blue	Harness Routing
Yellow	Bed Wire Pass Thru

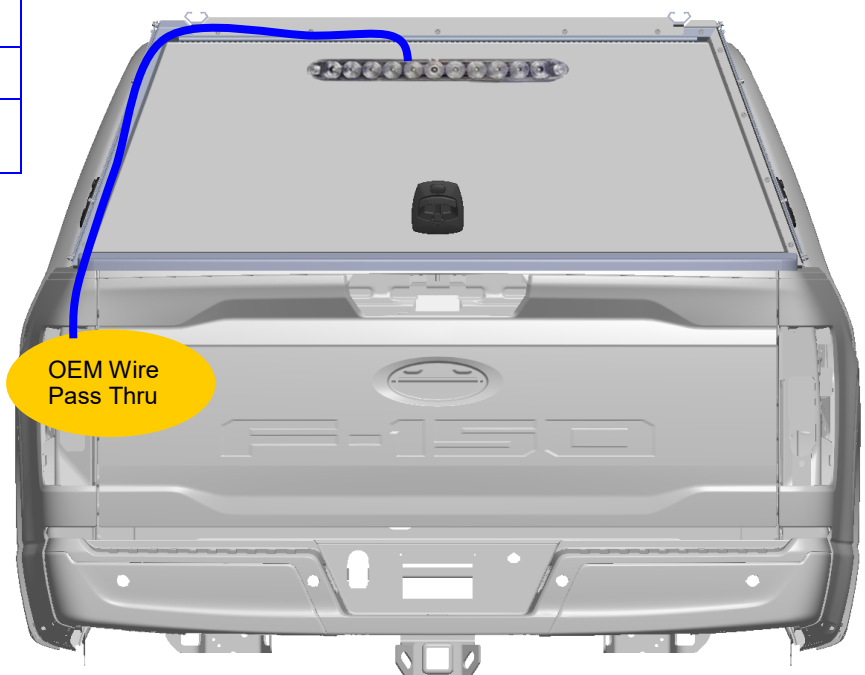



Step 1: Locate the brake light harness 71668.

Remove the fuse from the inline fuse holder until the end of the install.

Step 2: Open the vehicle hood.

Locate the driver's side frame OEM harness. Follow the harness forward of the truck, until you reach the hood shock area.

There will be a small grey/orange wire separate from the OEM harness. It will have a black covering on the end.

*** Please note the Hybrid F150 may have a green/purple wire instead of grey/orange.

This is the OEM CHMSL circuit wire for the brake light.

Strip the wire covering and prepare it to be connected to the brake light harness.

Locate the end of the harness (PN71668) with the ring terminal and butt connector.

Use the butt connector to connect to the OEM CHMSL wire. Use a heat gun to shrink the butt connector once crimped on.



Step 3: Locate the OEM chassis ground located on the frame—forward of the CHMSL circuit.

Secure the ring terminal on the brake light harness to the chassis ground.

Torque the ground to 9Nm (80 in lb).



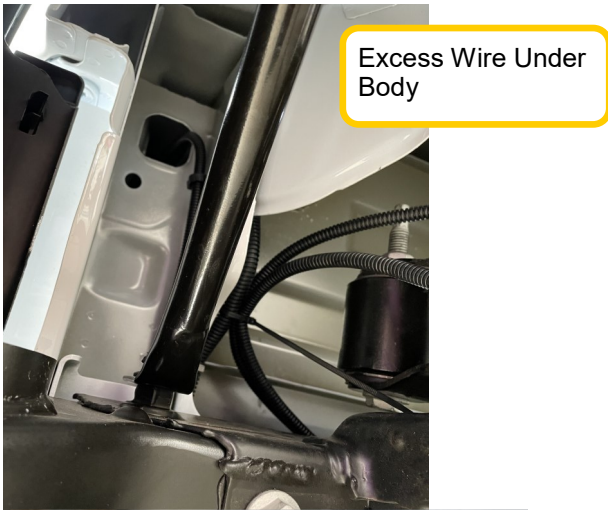

Step 4: Routing (Refer to routing diagrams at the beginning of the instructions)

Route the brake light harness rearward and down the engine compartment to the frame (red dotted line).

Follow the OEM wire harness on the frame rearward to the bumper of the truck.

Continue routing the harness upward in the bed cavity, to the bed wire pass thru.

Drill a hole in the OEM grommet, for the pass thru. If the grommet has a light in place of it, please utilize the round hole that is up and to the right of it.

If installing the interior lighting kit as well as the brake light kit, utilize the larger grommet supplied in the brake light harness bag.

If only installing the brake light harness, utilize the smaller grommet supplied in the brake light harness kit.

Drill (for larger grommet a 1" hole and 0.625" (5/8) hole for the smaller grommet) then route the wire harness through the grommet, to the underbody of the truck.

Silicone after routing through the grommet.

Tuck any excess wiring into the empty cavity underneath the bed frame.

For **REV B** of the harnesses there will be a tek screw and p-clip supplied in the bag. Bundle the excess wire in the cavity using zip ties. Use the tek screw and p-clip to secure the bundle to the frame.

Secure the wiring with zip ties.

DO NOT secure wiring to any brake lines.

Be sure the bundle of wire is secure and will not fall out over time.

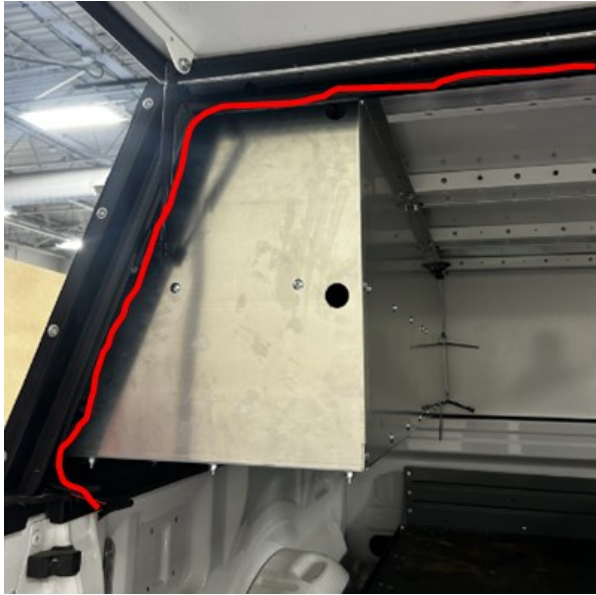

Step 5: Routing continued

Continue routing the brake light harness inside the topper, to the light.

The harness should run along the driver's side rear cavity, then across the top cavity to the light. (Red and blue lines shown in pictures)

Be sure to leave extra wire from the brake light to the topper rails before securing. This ensures the wires wont brake when the topper door opens and closes.

Clean the topper corner channel with alcohol pads or spray. Secure using zip ties and sticky back zip tie holders.

Connect the harness to the light:

Plug the connectors together. Pull connectors lightly to ensure they do not come apart.

Be sure the red wire on the harness connects to the black wire on the light. Then the black wire on the harness connects to the white wire on the light.

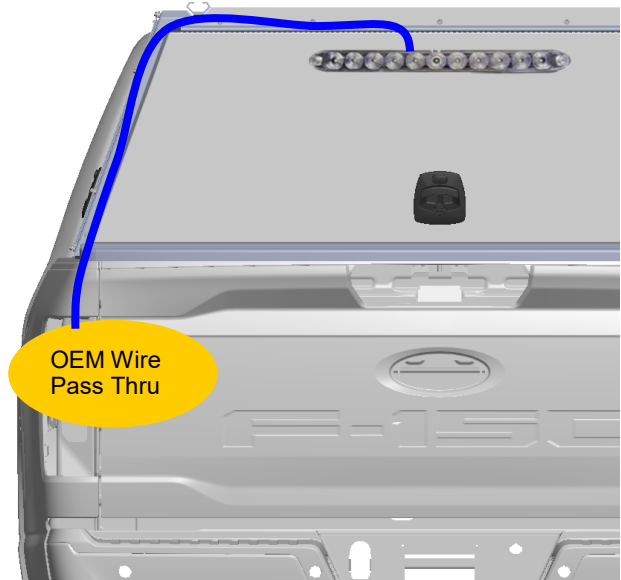

Insert the fuse into the inline-fuse holder on the brake light harness.

The install is now complete.

Check that the brake light comes on when the brake pedal is pushed, then back off once pedal is released.