

SHELF FRONT RAIL KIT Assembly Instructions FOR AD SERIES SHELVING

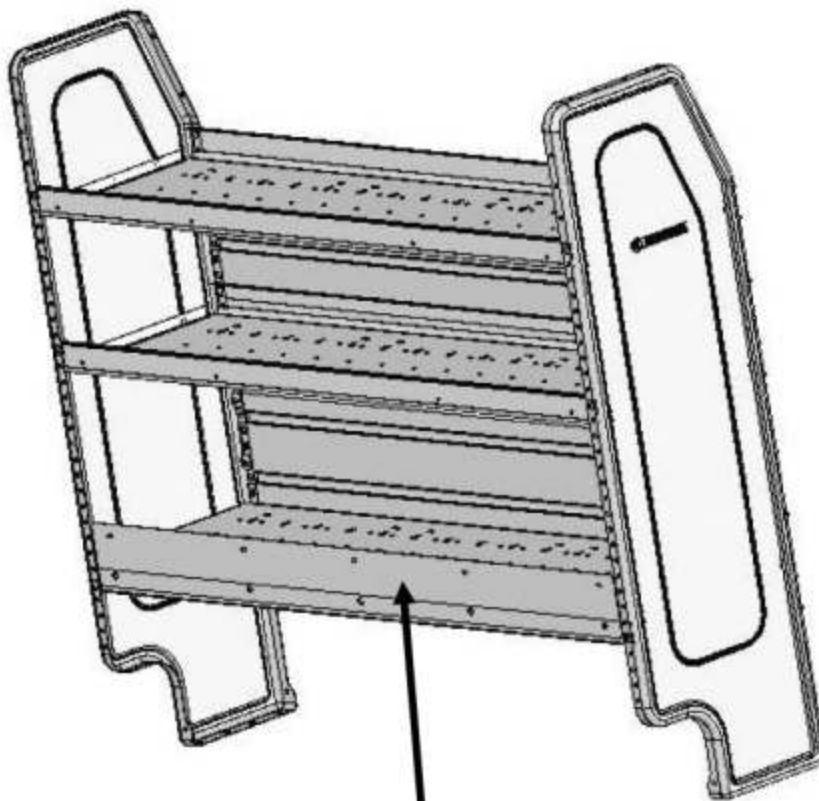

Front Shelf Rail
SRAD48 shown.

ECN-11867 DATE: 12/18/2008 DWG.BY: JLC REV.BY: RHS CHK.BY: RHS ISSUE: B P.N.: 37125-0

SHELF RAIL KIT SRAD30 & SRAD48

BEFORE YOU START!

IMPORTANT INSTALLATION STEPS ARE DENOTED USING A STOP SIGN. THESE STEPS MUST BE PERFORMED AS SPECIFIED IN ORDER TO ENSURE A PROPER INSTALLATION AND MUST BE FOLLOWED IN ORDER TO MAINTAIN YOUR PRODUCT WARRANTY!



CRITICAL INFORMATION PERTAINING TO USER AND/OR VEHICLE SAFETY IS DENOTED USING A CAUTION SIGN. SAFETY ITEMS MUST BE STRICTLY ADHERED TO IN ORDER TO ENSURE A SAFE WORKING ENVIRONMENT!



Tools Needed for this Install

#2 Point Phillips Screwdriver, 3/8" End Wrench
Drill Motor & 7/32" Drill Bits.



THE USE OF AIR OR ELECTRIC IMPACT TOOLS FOR THE ASSEMBLY OF FASTENERS IS NOT RECOMMENDED AND COULD CAUSE FASTENER FAILURE!



WARNING



THE USE OF DRILLS WITH INTEGRAL DRILL STOPS ALONG WITH PROPER INSPECTION FOR GAS TANK, GAS LINES, BRAKE LINES AND ELECTRICAL LINES PRIOR TO DRILLING ANY MOUNTING HOLES IS STRONGLY RECOMMENDED TO ENSURE THAT VEHICLE DAMAGE IS AVOIDED!



THE USE OF NON-STANDARD FASTENERS AND/OR DEVIATING FROM THE FASTENERS SPECIFIED IN THE INSTRUCTION (S) MAY VOID YOUR PRODUCT WARRANTY!





ALL DRILLED HOLES IN THE VEHICLE SHOULD HAVE THE RAW METAL EDGES SEALED WITH A SELF-ETCHING PRIMER TO RESIST CORROSION AND POTENTIAL FASTENER POINT FAILURE!

SHELF RAIL KIT SRAD30 & SRAD48

STEP - 01

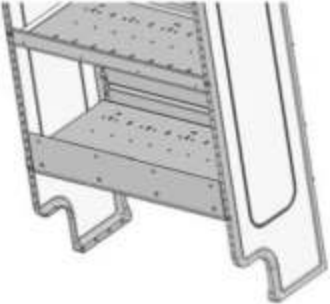
PLACE FULL SHELF RAIL ON FRONT OF SHELF

Please refer to the detail views below for clarification.

 <p>30" Full Rail shown on bottom shelf</p>	 <p>Shelf Rail SRAD30 (shown) (1) Required</p>	 <p>FAS0020 Nut, Hex Flange, #10-24UNC Qty = 4 - 5 Torque Specifications <u>23 in-lbs +/- 3 in-lbs</u></p>	 <p>FAS0025 Screw, Truss Head, #10-24UNCx1/2" Qty = 4 - 5 Torque Specifications <u>23 in-lbs +/- 3 in-lbs</u></p>
---	---	--	--

Attach Shelf Rail with Screws, placing nuts on back side. Torque fasteners as specified.

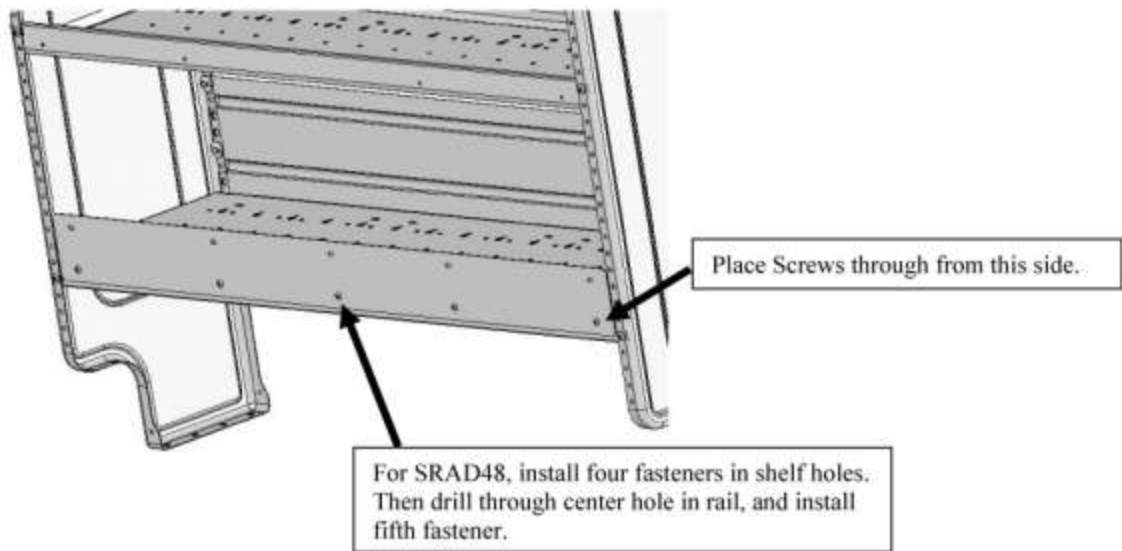

DOUBLE-CHECK ALL FASTENER LOCATIONS TO BE SURE THAT ALL FASTENERS ARE TIGHTENED TO SPECIFIED TORQUE!

