

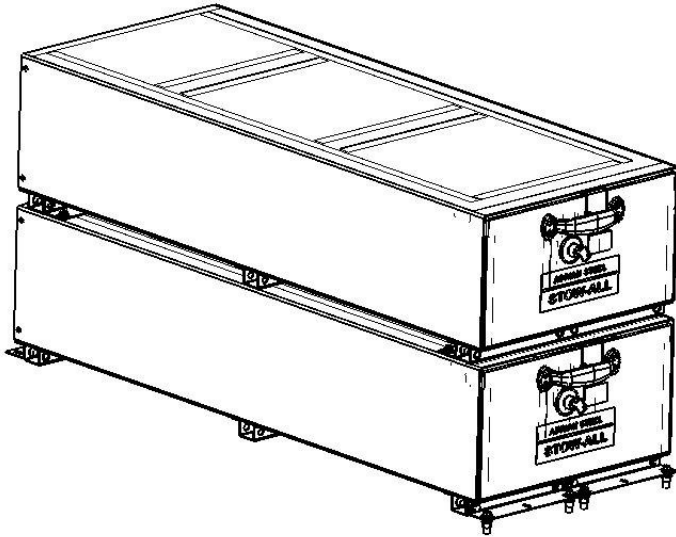

**ADRIAN STEEL®**

*Cargo Management Solutions for Commercial Vehicles*

## Generic Assembly/Installation Instructions and Owners



TYPICAL STACKED STOWALL  
INSTALLATION

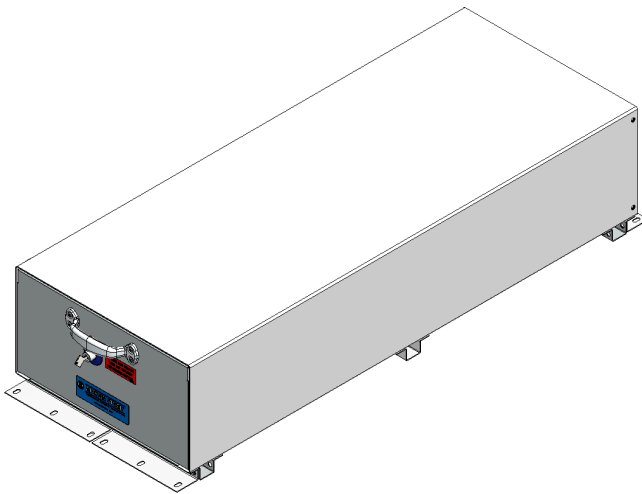

**SA-20**  
STOWALL, DOUBLE  
SHOWING SINGLE AND  
STACKED  
CONFIGURATION

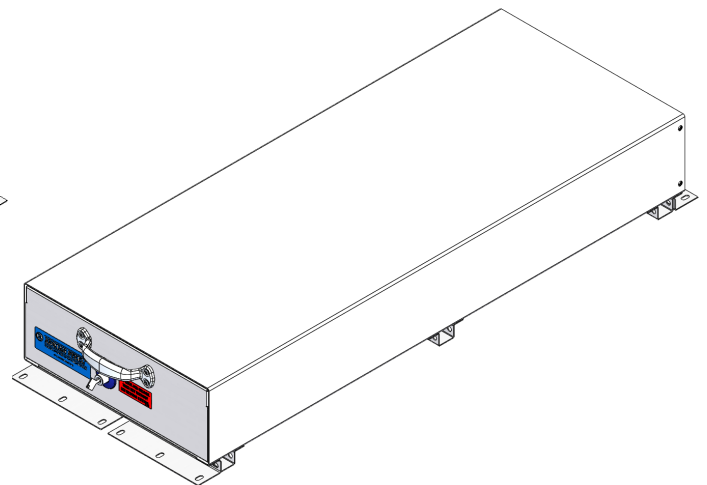

**SAJ-20**  
STOWALL/SHALLOW, DOUBLE  
SHOWING SINGLE AND  
STACKED  
CONFIGURATION



**ADRIAN STEEL®**

*Cargo Management Solutions for Commercial Vehicles*

## Generic Assembly/Installation Instructions and Owners

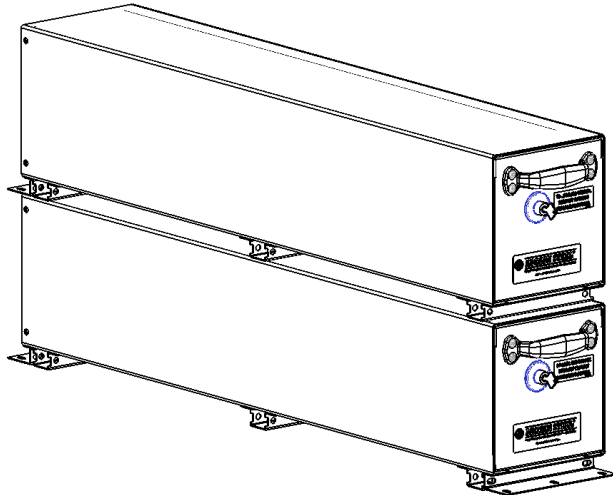

TYPICAL STACKED STOWALL  
INSTALLATION

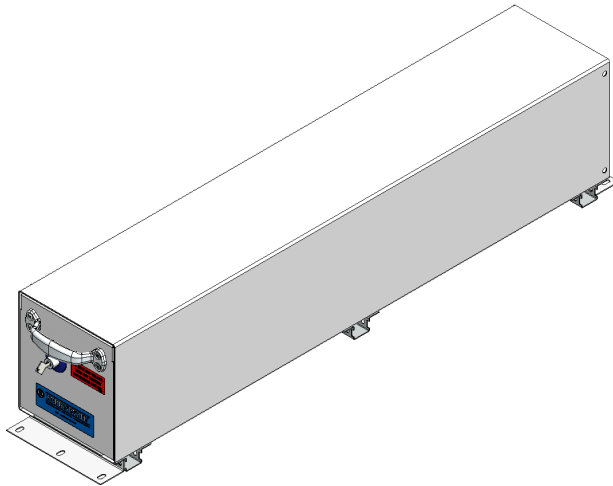

**SA-10**  
STOWALL, SINGLE  
SHOWING SINGLE AND  
STACKED  
CONFIGURATION  
(not shown in  
instruction)

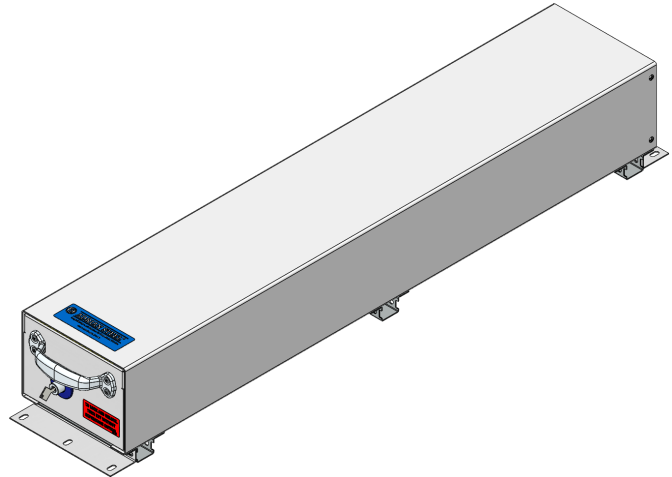

**SAJ-10**  
STOWALL/SHALLOW, SINGLE  
SHOWING SINGLE AND  
STACKED  
CONFIGURATION  
(not shown in  
instruction)



**ADRIAN STEEL®**

*Cargo Management Solutions for Commercial Vehicles*

## Generic Assembly/Installation Instructions and Owners

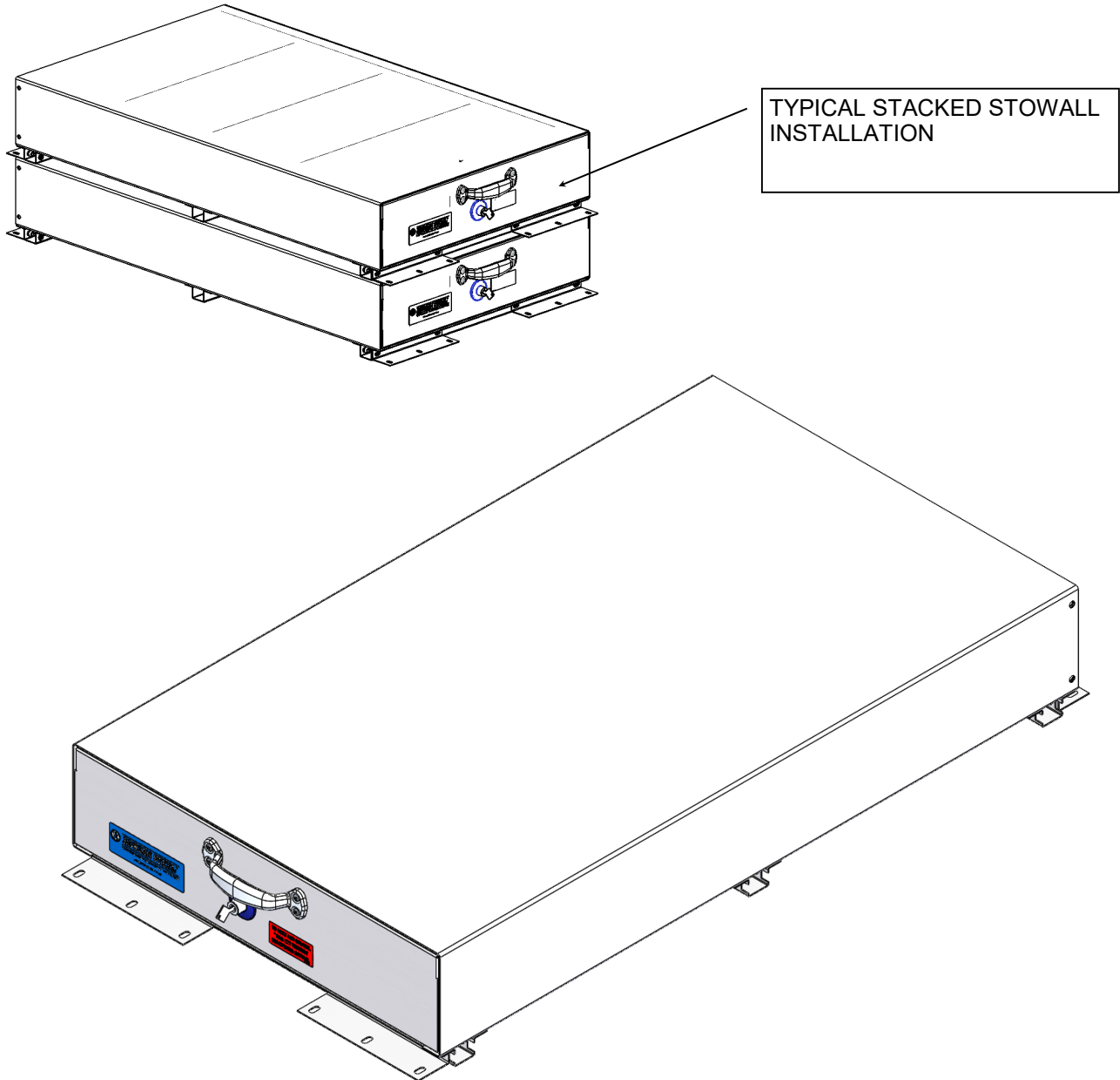

**SAJ-30**  
**STOWALL, SHALLOW, TRIPLE**  
**SHOWING SINGLE AND STACKED CONFIGURATION**  
**(not shown in instruction)**



**ADRIAN STEEL®**

*Cargo Management Solutions for Commercial Vehicles*

## Generic Assembly/Installation Instructions and Owners

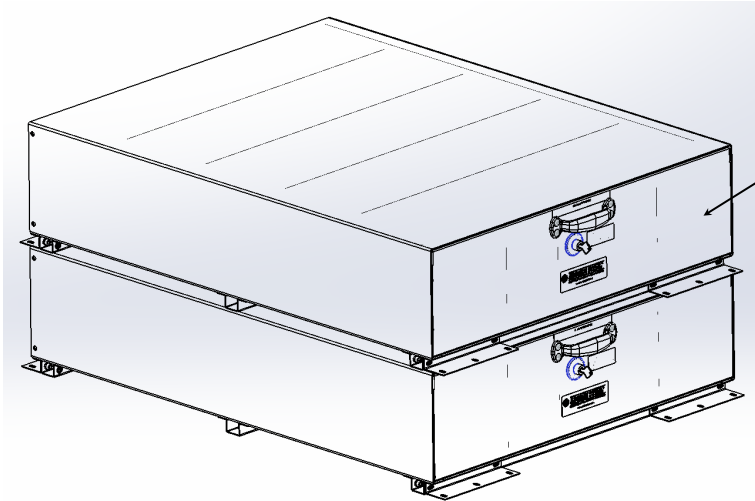

TYPICAL STACKED STOWALL  
INSTALLATION

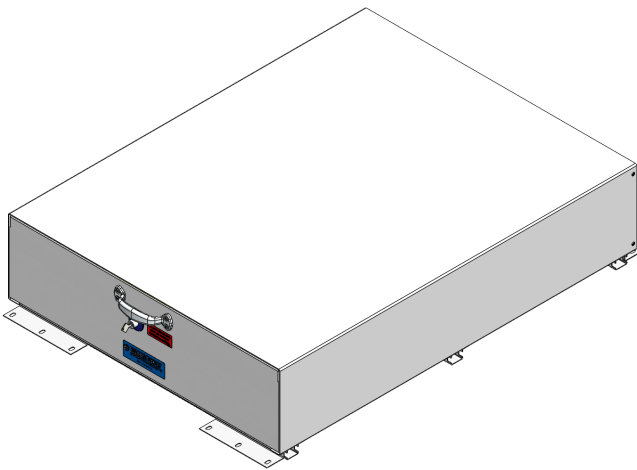

**SA-40**  
STEELER STOW-ALL, QUAD  
SHOWING SINGLE AND  
STACKED CONFIGURATION  
(not shown in instruction)

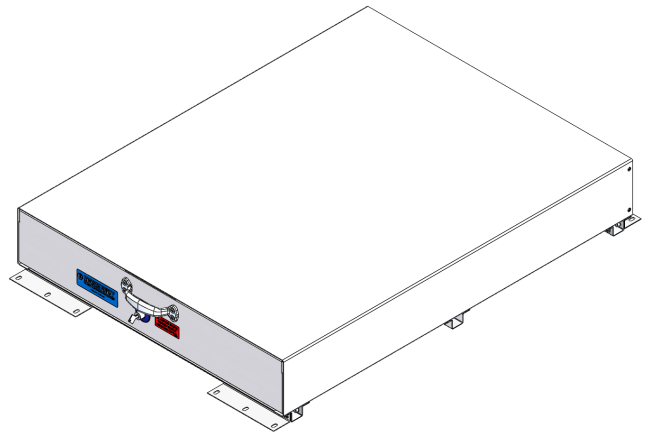

**SAJ-40**  
STOW-ALL/SHALLOW, QUAD  
SHOWING SINGLE AND  
STACKED CONFIGURATION  
(not shown in instruction)

## - PRECAUTIONS -





 **CAUTION**   
**THE USE AIR IMPACT TOOLS CAN  
OVER-TORQUE FASTENERS AND  
CAUSE FASTENER FAILURE!**



 **CAUTION**   
**ALL INSTALLATION HOLES SHOULD BE SEALED  
WITH SILICON OR BUTYL SEALANT TO PREVENT  
EXHAUST FUMES FROM ENTERING THE VEHICLE!**



 **DANGER**   
**INSPECT FOR FUEL TANK, FUEL LINES, BRAKE LINES, HIGH  
VOLTAGE BATTERIES AND ELECTRICAL LINES PRIOR TO  
DRILLING TO AVOID DAMAGING CRITICAL VEHICLE SYSTEMS  
OR INJURY TO INSTALLER DURING INSTALLATION PROCESS!**



 **CAUTION**   
**TO AVOID DAMAGING THE VEHICLE ALWAYS  
USE DRILL STOPS WHEN DRILLING ANY IN-  
STALLATION HOLES!**



## - IMPORTANT WARRANTY REQUIREMENTS -

1. SUBSTITUTING ADRIAN STEEL SPECIFIED FASTENERS FOR ASSEMBLY AND/OR INSTALLATION WILL VOID YOUR PRODUCT WARRANTY.
2. ALL HOLES DRILLED INTO VEHICLE SHOULD HAVE THE RAW METAL EDGES SEALED WITH A SELF-ETCHING PRIMER TO RESIST CORROSION AND POTENTIAL FASTENER POINT FAILURE.
3. ALL FASTENERS USED IN THE INSTALLATION OF THIS PRODUCT SHOULD BE TIGHTENED TO THE TORQUE(S) SPECIFIED IN THESE INSTRUCTIONS.
4. THESE INSTRUCTIONS SHOULD BE KEPT WITH THE VEHICLE.

### THE BASIC TOOLS NEEDED FOR MOST INSTALLATIONS



DRILL



DRILL BIT WITH  
STOP

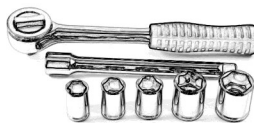

RATCHET, SOCKETS  
AND/OR WRENCHES



SCREWDRIVERS



MEASURING TAPE

ADDITIONAL TOOLS MAY BE NEEDED FOR THIS INSTALLATION AND THEY WILL BE IDENTIFIED IN THE STEPS THAT FOLLOW.

**Installation and/or Assembly Fasteners**  
**BAGSA-10-B**  
**(TO BE USED WITH SA-10 & SAJ-10)**

ITEM NO.	PART NUMBER	DESCRIPTION	QTY.
1	BAG0507-A	5" x 7" 3MIL AUTOBAG	1
2	FAS0759	U-NUT,5/16-18 ZP	4
3	FAS0438	SCREW,HFLNG 5/16-18X.75 ZP	4
4	FAS0092	Screw, Hex Hd, 5/16-18x1.50 Zn Plate, G8	6
5	FAS0082	SCREW,HH 5/16-18X1 G8 ZNY	4
6	FAS0086	WASHER,FLAT USS 5/16 ZP	10
7	FAS0098	Washer, Lock, Split, 5/16, Zinc Plate	10
8	FAS0091	Plusnut, 5/16	6
9	03927-1	SPACER,FLR,1010,11/32 ZP	3
10	03927-2	SPACER, FLR, 1010, 11/16 ZP	3

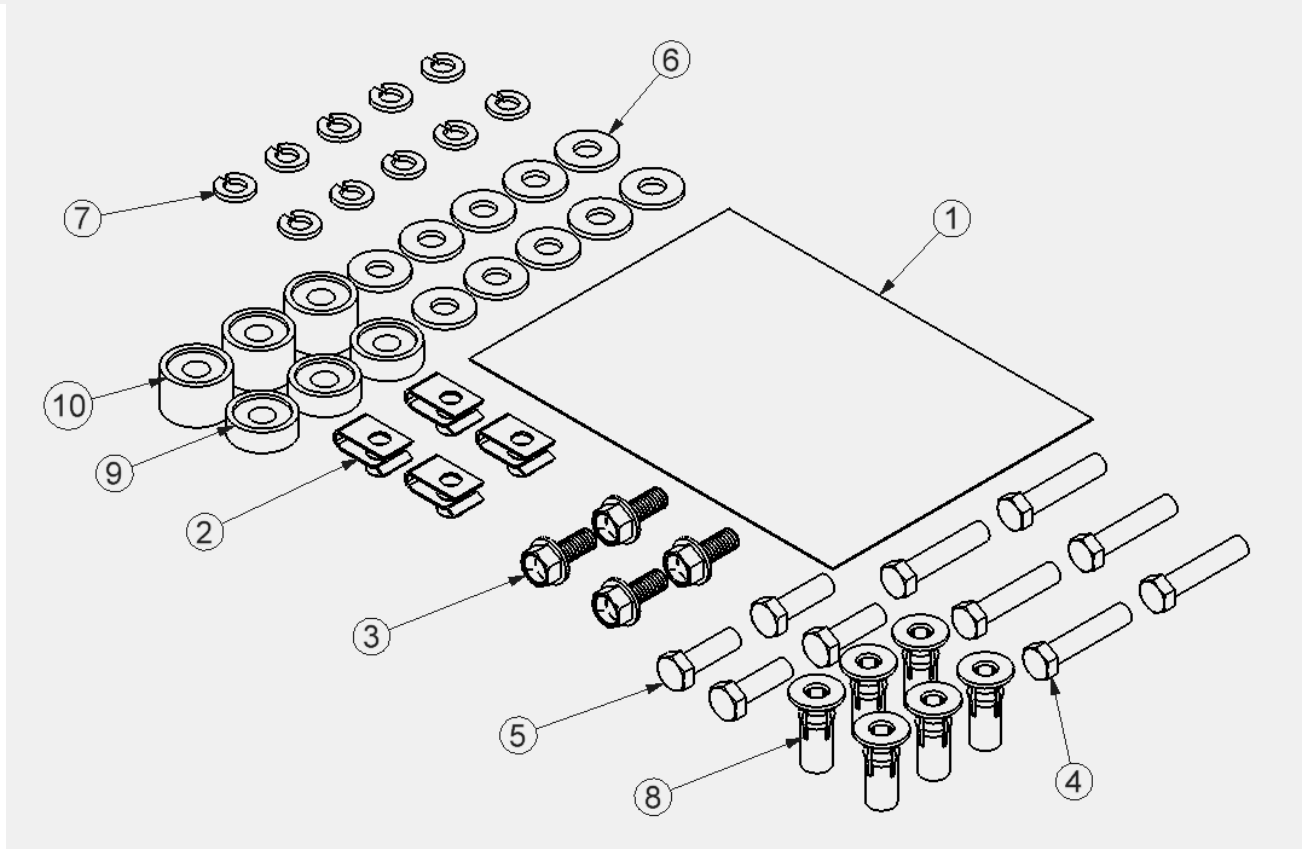

**Installation and/or Assembly Fasteners**  
**BAG64491**  
**(TO BE USED WITH SA-20, SAJ-20, SAJ-30, SA-40 & SAJ-40)**

ITEM NO.	PART NUMBER	DESCRIPTION	QTY.
1	BAG0507-A	5" x 7" 3MIL AUTOBAG	1
2	FAS0759	U-NUT,5/16-18 ZP	8
3	FAS0438	SCREW,HFLNG 5/16-18X.75 ZP	8
4	FAS0092	Screw, Hex Hd, 5/16-18x1.50 Zn Plate, G8	12
5	FAS0082	SCREW,HH 5/16-18X1 G8 ZNY	8
6	FAS0086	WASHER,FLAT USS 5/16 ZP	20
7	FAS0098	Washer, Lock, Split, 5/16, Zinc Plate	20
8	FAS0091	Plusnut, 5/16	12
9	03927-1	SPACER,FLR,1010,11/32 ZP	6
10	03927-2	SPACER, FLR, 1010, 11/16 ZP	6

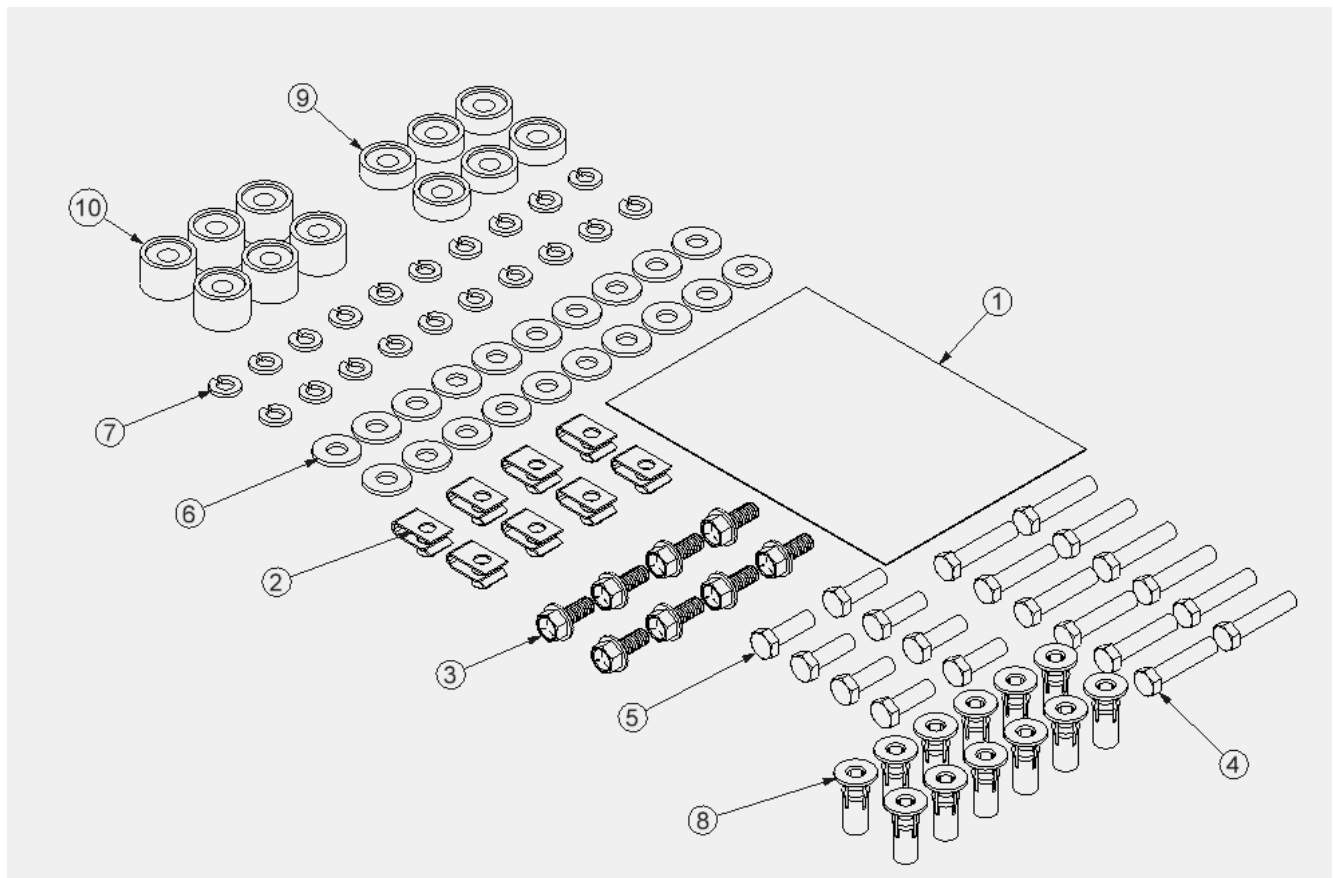

# Instructions for Step 01

Add the drawer floor mounting brackets

## BRACKET ORIENTATION

VIEW FROM TOP SIDE OUTSIDE CURBSIDE DOOR

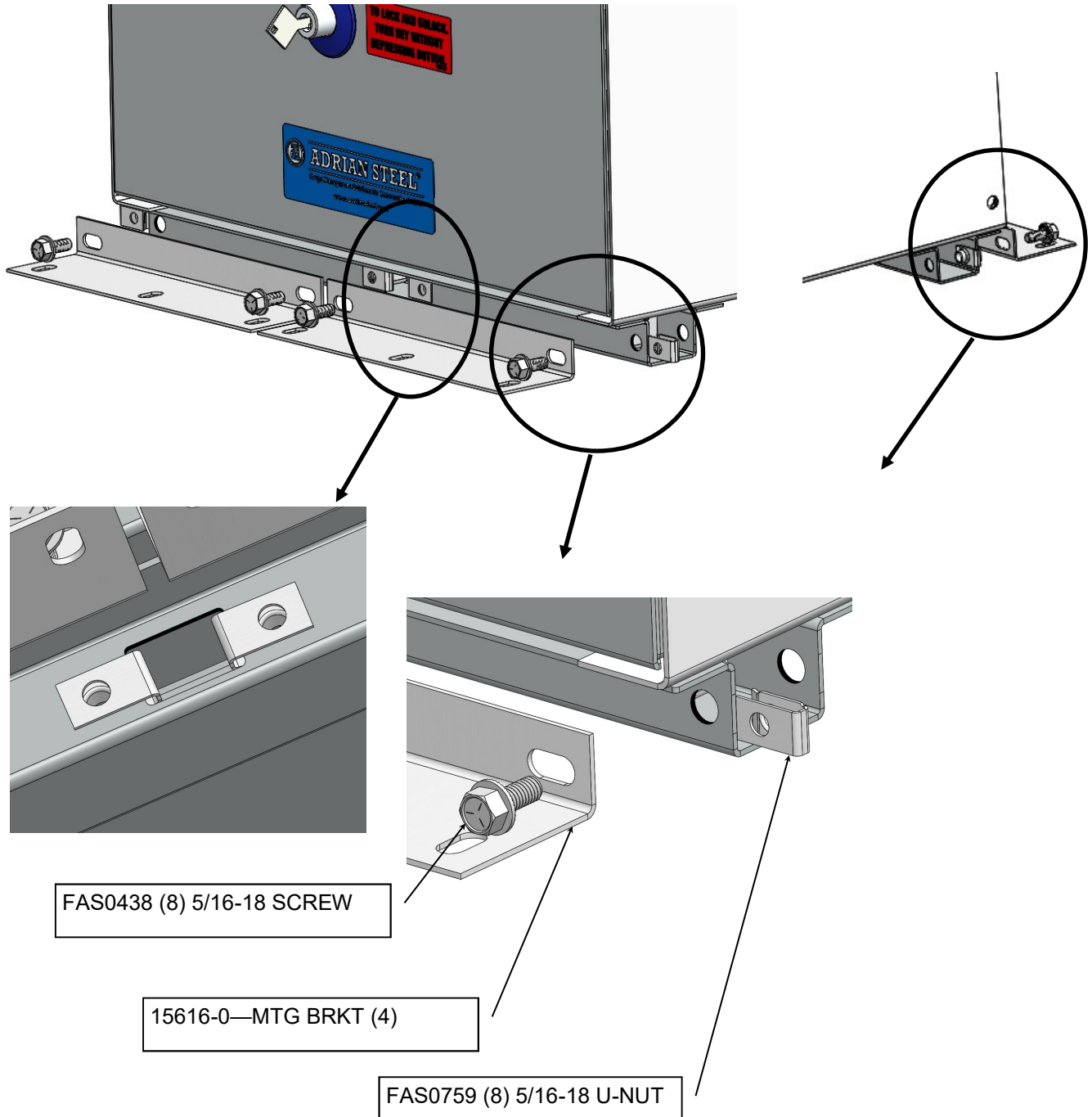

# Instructions for Step 02

## LOCATE AND SET PLUSNUTS

Place your Stow-all in desired position in vehicle (ref: PDS documentation). Mark the floor through slots in the Drawer Floor Mount Brackets in preparation for installing the 5/16-18UNC plusnuts. Remove Stow-all from vehicle and set aside at this time.

**NOTE: Before drilling through holes for plusnut installation inspect for electrical wiring, gas tank location, and/or control lines. Use drill bit with a stop collar as outlined in first part of this instruction.**

Once plusnuts have been installed, reposition Stow-all and align slots in the Drawer Floor Mount Brackets. Secure in place with the fasteners listed above and tighten to the recommended torque of **17 ft-lbs +/- 2 ft-lbs**.

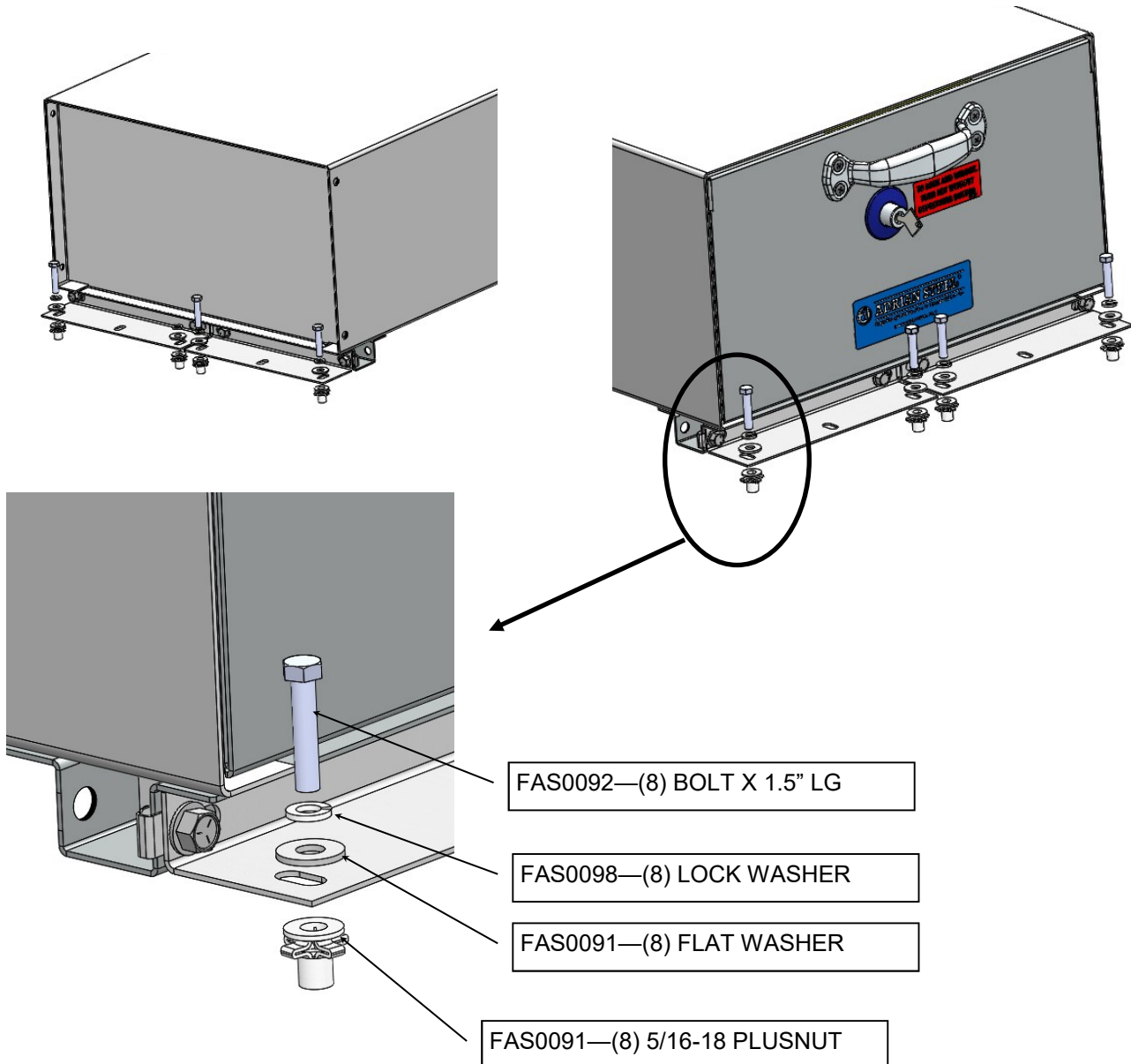

# Instructions for Step 03

STACKED STOWALLS—ADD FLOOR MOUNTING BRACKETS USING STEP 1 AS YOUR GUIDE

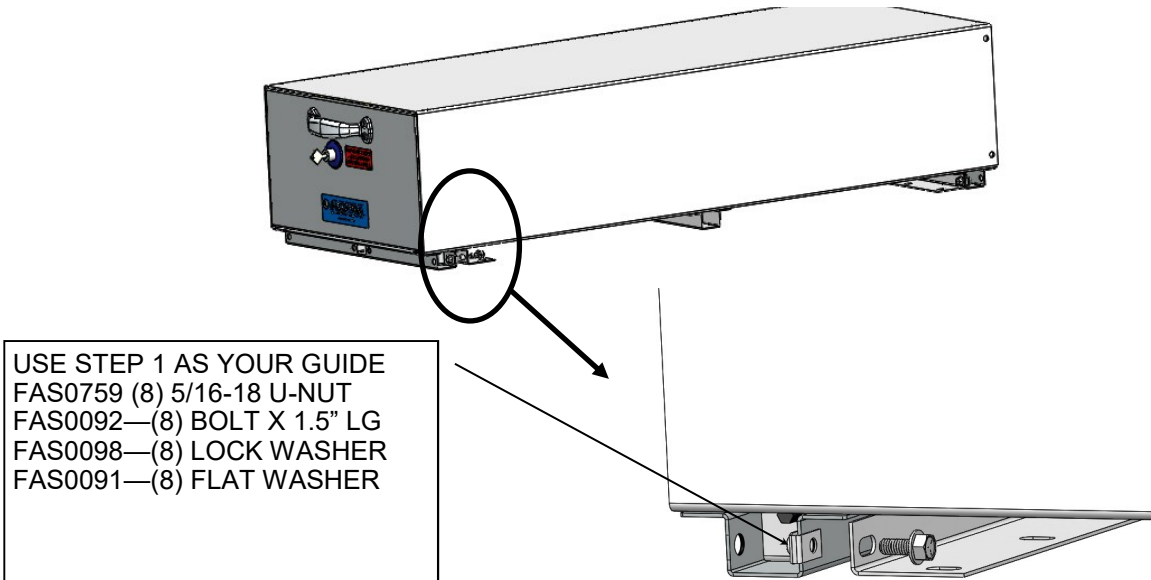

Place your Upper Stow-all on top of the previously installed Stow-all as shown in detail views below. Mark the (4) outer corner floor through slots in the Drawer Floor Mount Brackets in preparation for installing the 5/16-18UNC plusnuts into the lower Stow-all. Remove the upper Stow-all from vehicle and set aside at this time.

**NOTE:** After drilling through the outer wrapper of the lower Stowall, continue drilling through the inner Rail Channels spot welded to the upper interior surface of the lower Stow-all wrapper. This will allow clearance for the plusnut body required for proper seating of the plusnuts.

Once plusnuts have been installed in the lower Stow-all, reposition upper Stow-all and align slots in the Drawer Floor Mount Brackets. Secure in place with the fasteners listed above and tighten to the recommended torque of **17 ft-lbs +/- 2 ft-lbs**.

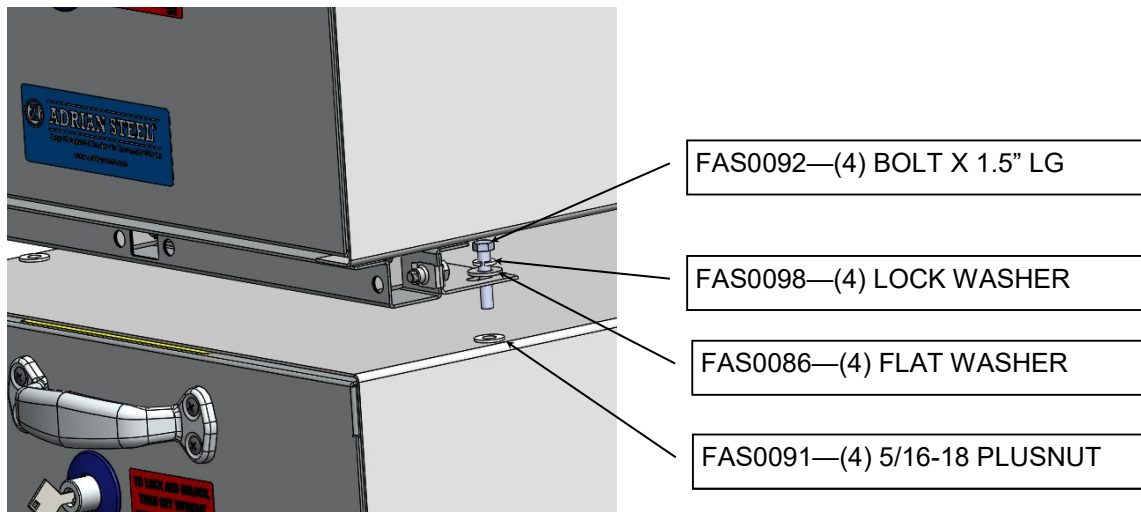

## ATTENTION!

It is advised that “all fasteners” that assemble and install your Stow-all is “checked for tightness” at (2) weeks operation and then rechecked again at (6) weeks of operation.

Assembly fasteners could loosen due to vibration through your vehicle while on the road or in and out of construction sites.

This is a preventative maintenance step to ensure your Stow-all give you a long service life.



**ATTENTION INSTALLERS!** Any seat belt components including not limited to buckles and retractors that are removed during installation must be reconnected (electrically) and secured in the vehicle upon completion. Failure to do so will result in warning lamps and possible disablement of the air bag system.



***DOUBLE-CHECK ALL FASTENER LOCATIONS TO BE SURE THAT ALL FASTENERS ARE TIGHTENED TO SPECIFICATIONS!***



**YOUR INSTALLATION IS NOW COMPLETE! STOW THIS COPY IN THE VEHICLE FOR FUTURE REFERANCE!**

## NOTE!

**For Stow-all Drawer units that Will Not Open See the next two sections for Field Fix Options**

**STOW-ALL DIVIDER WILL NOT OPEN FIELD FIX OPTION #1**

**“PUSH-BUTTON CAM (29146-0) TO LATCH BOLT ASM LEVER ARM ( 34102-0) HDW RE-ALIGNMENT”**

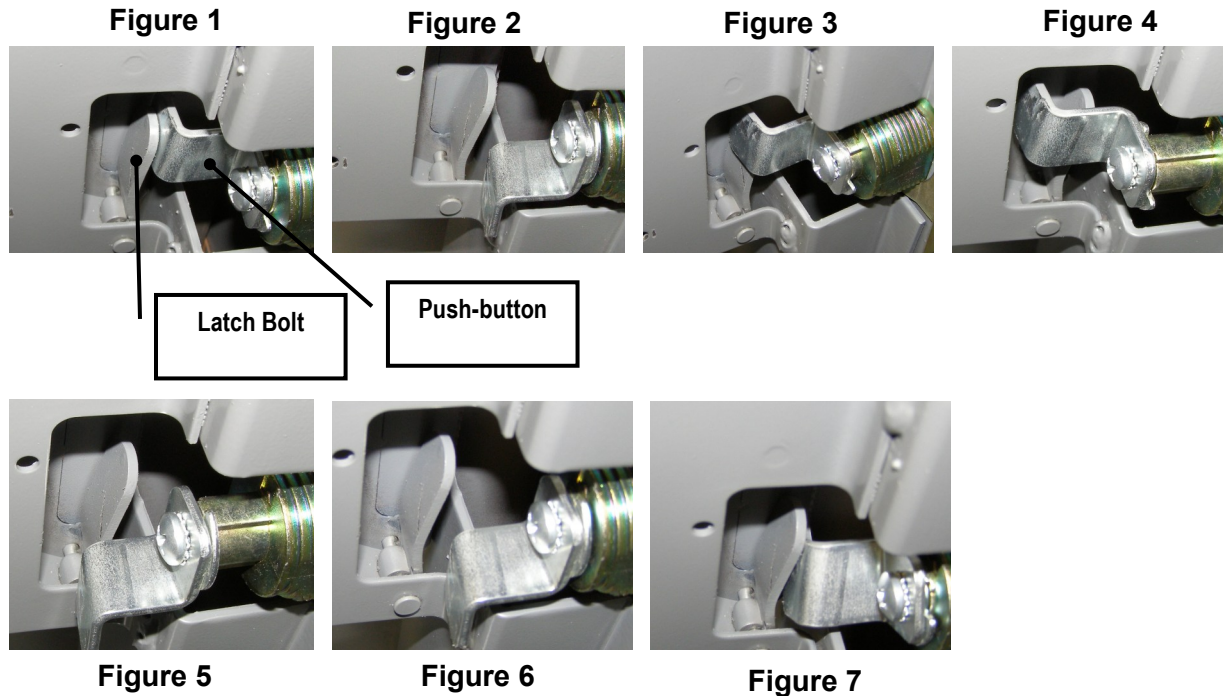

**Figure 1**

Nominal push-button cam to latch bolt assembly lever arm configuration for proper opening and closing of your stow-all.

**Figure 2**

Shows the push-button cam in the normal “drawer locked position”.

**Figure 3**

Shows misalignment of hardware, stow-all drawer will not open when pushbutton is depressed.

**Figure 4**

Realignment begins by inserting the key into the push-button and fully depressing the push-button mechanism.

**Figure 5**

While push-button is fully depressed, rotate key 90 deg. Clockwise.

**Figure 6**

Remove force holding the push-button fully depressed and allow to return to normal position.

**Figure 7**

Rotate key 90 deg. Counter-Clockwise. This should allow the push-button cam to engage behind the latch bolt asm lever arm. When key is returned to the original starting position, the push-button latch cam and latch bolt lever arm should be as shown in *Figure 1*. Normal stow-all drawer operation should be possible at this time. If not, repeat procedure one more time. If after the second attempt fails, proceed to next section (Field Fix Option #2).

**STOW-ALL DIVIDER WILL NOT OPEN FIELD FIX OPTION #2**

**“Manual depressing the Latch Bolt through access hole in stow-all outer housing” (similar to 29529-0)**

Measure (2) centerlines on top of your Stowall per dimensions shown below and mark centerline crossing point with a permanent marker. Drill a 0.375” diameter hole through the top surface of the stow-all outer housing.

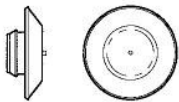
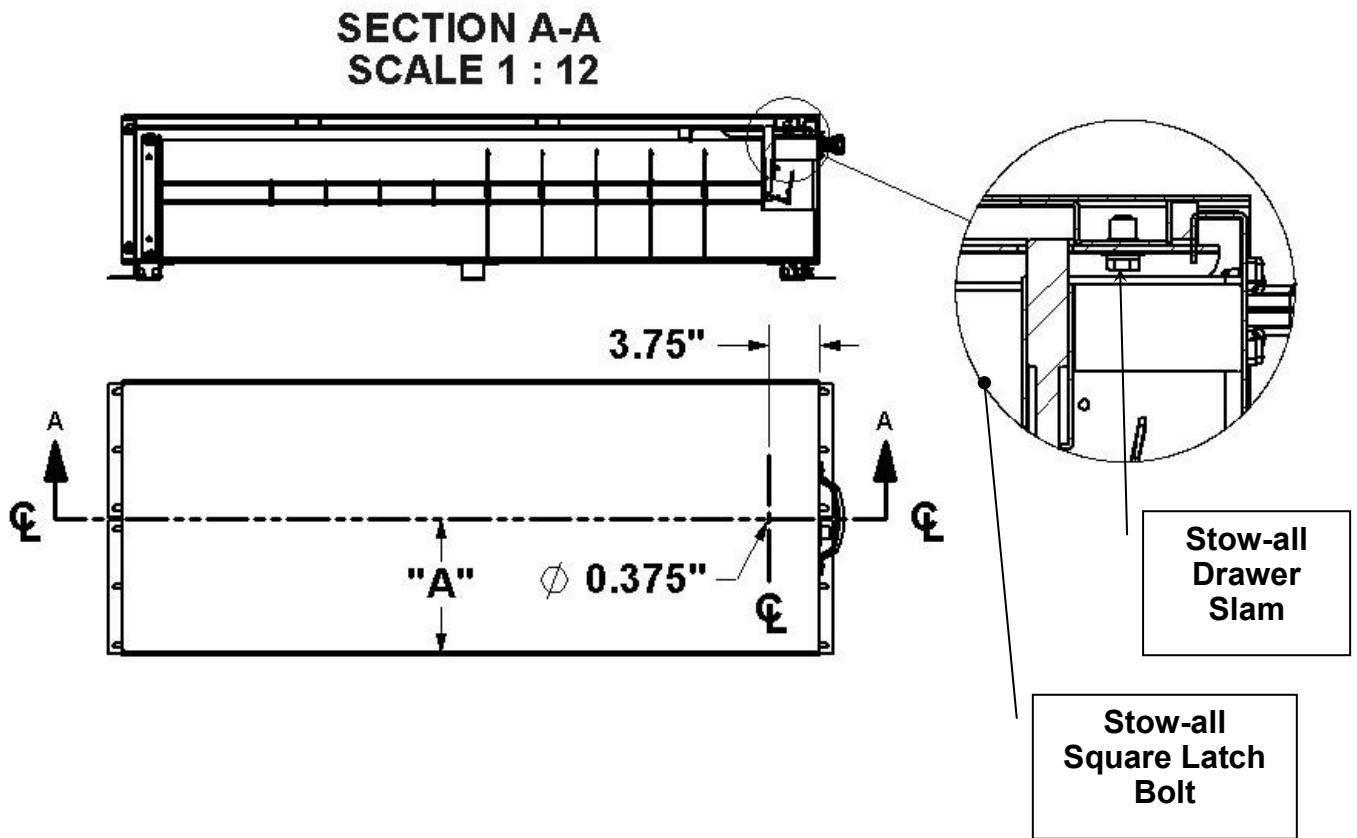

**CAP PLUG (21407-0)**

**DIMENSION "A"**  
SA-10 / SAJ-10 = 5"  
SA-20 / SAJ-20 = 10"  
SA-30 / SAJ-30 = 14.812"