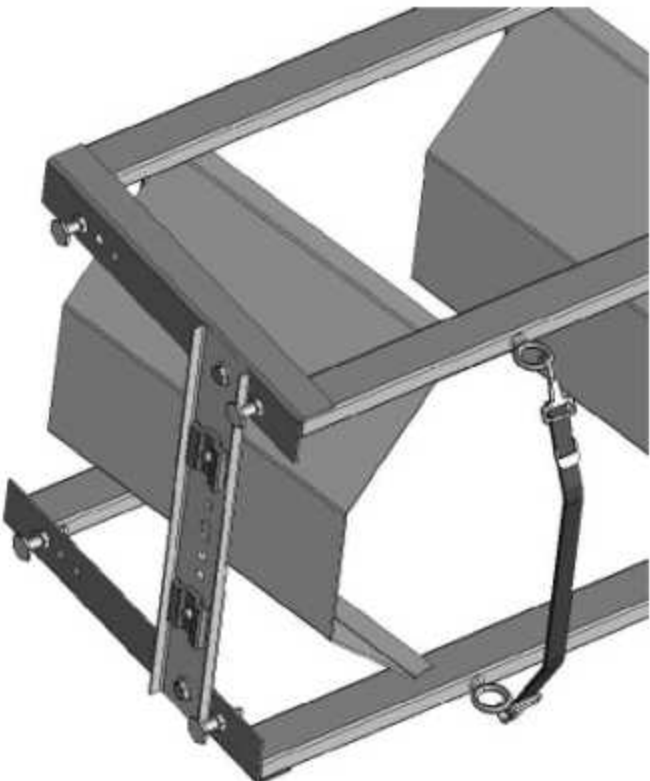

**ADRIAN STEEL**

Cargo Management Solutions for Commercial Vehicles

**Assembly/Installation Instructions and Owners Manual****RKAWTR  
RAIL ADAPTER KIT FOR WELDED TANK RACKS**

ADRIAN STEEL COMPANY • WWW.ADRIANSTEEL.COM • 306 JAMES STREET • ADRIAK, IN 46021 • 306-477-4726

Publication Number: 30796-0

Revision Level: B

ECN Release: 13014

**ADRIAN STEEL**

Cargo Management Solutions for Commercial Vehicles

Assembly/Installation Instructions and Owners Manual

**- PRECAUTIONS -**

**CAUTION**  THE USE AIR IMPACT TOOLS CAN OVER-TORQUE FASTENERS AND CAUSE FASTENER FAILURE!



**CAUTION**  ALL INSTALLATION HOLES SHOULD BE SEALED WITH SILICON OR BUTYL SEALANT TO PREVENT EXHAUST FUMES FROM ENTERING THE VEHICLE!



**DANGER**  INSPECT FOR FUEL TANK, FUEL LINES, BRAKE LINES, HIGH VOLTAGE BATTERIES AND ELECTRICAL LINES PRIOR TO DRILLING TO AVOID DAMAGING CRITICAL VEHICLE SYSTEMS OR INJURY TO INSTALLER DURING INSTALLATION PROCESS!



**CAUTION**  TO AVOID DAMAGING THE VEHICLE ALWAYS USE DRILL STOPS WHEN DRILLING ANY IN-STALLATION HOLES!

**- IMPORTANT WARRANTY REQUIREMENTS -**

1. SUBSTITUTING ADRIAN STEEL SPECIFIED FASTENERS FOR ASSEMBLY AND/OR INSTALLATION WILL VOID YOUR PRODUCT WARRANTY.
2. ALL HOLES DRILLED INTO VEHICLE SHOULD HAVE THE RAW METAL EDGES SEALED WITH A SELF-ETCHING PRIMER TO RESIST CORROSION AND POTENTIAL FASTENER POINT FAILURE.
3. ALL FASTENERS USED IN THE INSTALLATION OF THIS PRODUCT SHOULD BE TIGHTENED TO THE TORQUE(S) SPECIFIED IN THESE INSTRUCTIONS.
4. THESE INSTRUCTIONS SHOULD BE KEPT WITH THE VEHICLE.

**THE BASIC TOOLS NEEDED FOR MOST INSTALLATIONS**

ADDITIONAL TOOLS MAY BE NEEDED FOR THIS INSTALLATION AND THEY WILL BE IDENTIFIED IN THE STEPS THAT FOLLOW.

ADRIAN STEEL COMPANY • WWW.ADRIANSTEEL.COM • 306 JAMES STREET • ADRIAK, IN 46021 • 306-477-4726

Publication Number: 30796-0

Revision Level: B

ECN Release: 13014

WHEN INSTALLING PLUSNUTS MAKE SURE YOU USE THE CORRECT DRILL BIT WITH A STOP!

PLUSNUT SIZE	DRILL BIT SIZE
1/2" 20 PLUSNUT, FAS0062	USE A 3/8" DIAMETER DRILL BIT WITH A STOP.
5/16"-18 PLUSNUT, FAS0091	USE A 1/2" DIAMETER DRILL BIT WITH A STOP.

NOTE: A PLUSNUT SETTING TOOL IS REQUIRED FOR PLUSNUT INSTALLATION AND IS NOT SUPPLIED WITH THE KIT. CONTACT PLUSNUT TOOLS FOR AN ADRIAN STEEL P.N. 5250-0101 USE AN AIR POWERED PLUSNUT SETTING TOOL.

NOTE: If your vehicle contains carpet or a rubber floor mat you will need to prepare the mounting locations using a 1/32" CARPET CUTTER.

1/32" DIAMETER CARPET CUTTER

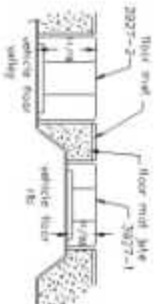
**Step 01 optional**

If your vehicle contains carpet or a rubber floor mat you will need to prepare the mounting location. **(if not, skip to step 02)**

Position the product to be installed into the vehicle and once your site is satisfied with the mounting location, mark the mounting location. Using a 1/32" diameter carpet cutter, cut the appropriate floor opening as shown in the illustration to the left. See these details for use later into the installation process.

Once you have prepared the carpet/floor mat for



**Step 02**

Using a drill and drill bit (see table at top of page for correct size) drill the mounting holes in the vehicle floor metal to prepare for installing the Plusnuts.

If you are thru-drilling at any of the locations, simply drill a hole that is 1/16" larger than the last step's slot (drill locations).

Once you have drilled the holes into the vehicle, the inner metal edges should be sealed using a self-sealing primer to resist corrosion and potential rust/interior paint failure.

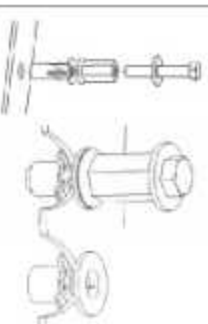

**Step 03**

**Setting Plusnuts**

Use a Power Head (Adrian's "Self-Aligning" or "Fixed" Head) and a Plusnut Setting Tool to install the Plusnuts. See the Plusnut Setting Tool instructions for details.

ADRIAN STEEL TOOLS, 300 JAMES STREET, ADRIAN, MI 48201 • 800-477-4776

ADRIAN STEEL COMPANY • WWW.ADRIANSTEEL.COM • 300 JAMES STREET • ADRIAN, MI 48201 • 800-477-4776

Publication Number: 30796-0

Revision Level: B

ECN Release: 13014

PARTS YOU WILL USE FOR	FASTENERS	QUANTITY	REMARKS
<p><b>STEP 04</b></p>		FA5006 (4) REQUIRED	FASTENERS (4) REQUIRED
		FA5070 (4) REQUIRED	FASTENERS (4) REQUIRED
		FA5074 (4) REQUIRED	FASTENERS (4) REQUIRED
		FA5013 (4) REQUIRED	FASTENERS (4) REQUIRED

**Instructions for Step 04**

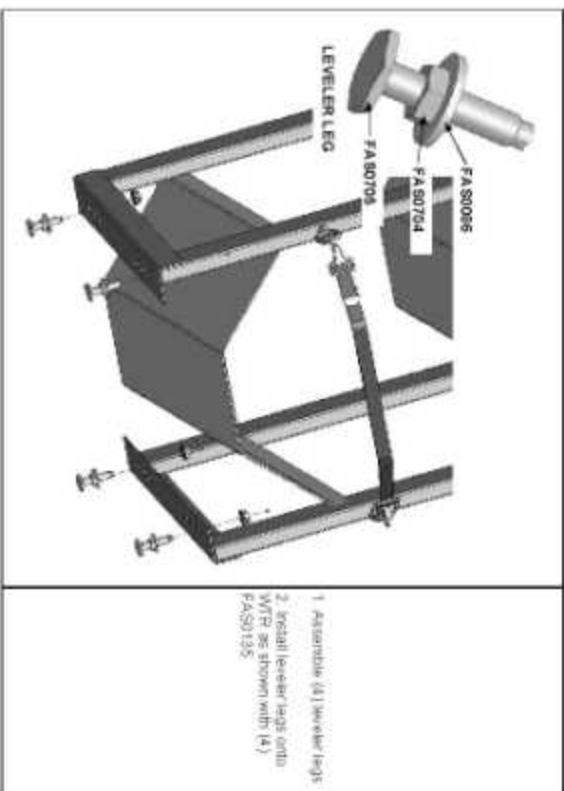



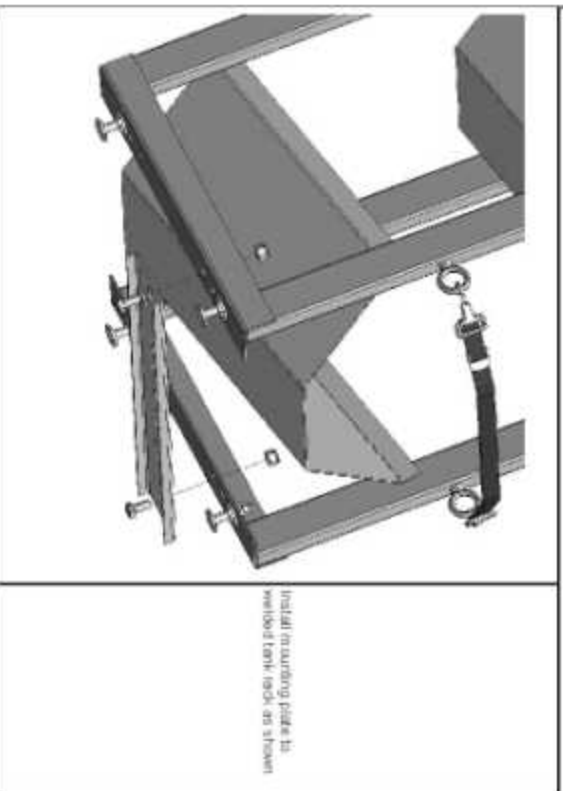

1. Assemble (4) leveler legs
2. Install leveler legs onto VTR as shown with (4) FA5013s

STEP	PARTS YOU WILL USE FOR			
				
<b>05</b>	Welded mounting plate (1) required	Fastener: screw/WH (2) required	Fastener: nut (2) required	Fastener: washer (2) required

## Instructions for Step 05



STEP	PARTS YOU WILL USE FOR			
				
<b>06</b>	Fastener: screw/WH (2) required	Fastener: washer/PLAT (2) required	Fastener: washer (2) required	90635-0 SLIDE-40-PAL (2) required

## Instructions for Step 06

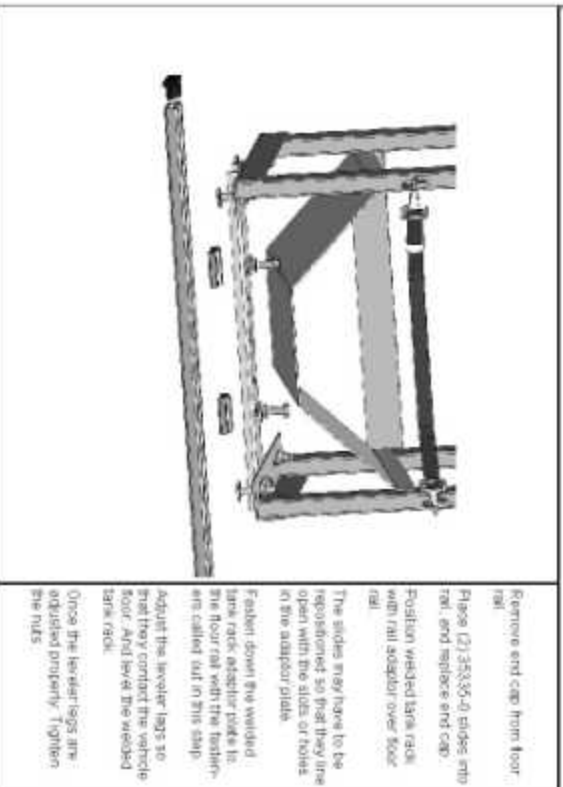

PARTS YOU WILL USE FOR	PARTS YOU WILL USE FOR	PARTS YOU WILL USE FOR	PARTS YOU WILL USE FOR	PARTS YOU WILL USE FOR
<p><b>STEP 07</b></p>	 <p>FASTENER: SCREW, HEX HEAD, 1/2" (1) REQUIRED</p>	 <p>FASTENER: WASHER, 1/2" (1) REQUIRED</p>	 <p>FASTENER: WASHER, 1/2" (1) REQUIRED</p>	 <p>FASTENER: SCREW, HEX HEAD, 1/2" (1) REQUIRED</p>
	 <p>FASTENER: BOLT, HEX HEAD, 1/2" (3) REQUIRED</p>	 <p>FASTENER: BOLT, HEX HEAD, 1/2" (3) REQUIRED</p>	 <p>FASTENER: BRACKET, L-SHAPED, 1/2" (3) REQUIRED</p>	 <p>FASTENER: WELDED TANK PACK, 1/2" (3) REQUIRED</p>

## Instructions for Step 07



Attach and assemble the mounting brackets as shown with the 1/4-20 fasteners.

Attach mounting brackets to the upper rail using the same method as described in the previous step.

**THE INSTALLATION OF THE WELDED TANK PACK TO THE RAIL SYSTEM IS COMPLETE.**

Torque all fasteners to 138 pounds.