

FASTENER GROUPS LISTED BELOW ARE USED FOR ASSEMBLY AND INSTALLATION. **SOME ASSEMBLY DRILLING IS REQUIRED.** PARTITION INSTRUCTIONS & FASTENERS ARE WITH THAT UNIT. USE KD UNIT DRAWINGS TO IDENTIFY THEIR SEPARATE PARTS. CUSTOMER SPECIFIED SHELF DIMENSIONS ARE SHOWN HERE.

SYM.	FASTENERS	QTY	DRILL
●	ASSEMBLY FASTENERS { 1/4-20 X 1/2" THP.SCW. { 1/4-20 HX. FLANGE NUT	(16) (16)	9/32
⊖	INSTALLATION FASTENERS { #14 X 3/4 "A" THP.SCW. { 1/4 EXT.L.WASHER	(4) (4)	3/16

ADRIAN STEEL CO.
906 JAMES STREET
ADRIAN, MI 49221
517/265-6194

RISER ASSEMBLY
2 X 12 X 17-3/4

DWG BY: MAE
ECN#: 6071
DATE: 6/27/02
CHK BY: [Signature]
PACKAGE # ISS: A
PACKAGE WEIGHT: 3.14 #
REFERENCE: REF 16437

ITEM	PART NO.	DESCRIPTION	QTY.
1	FR18	FLOOR RAIL 18"	2
2	FA12	FLOOR ANGLE 12"	2

SOME DRILLING MAY BE REQUIRED.

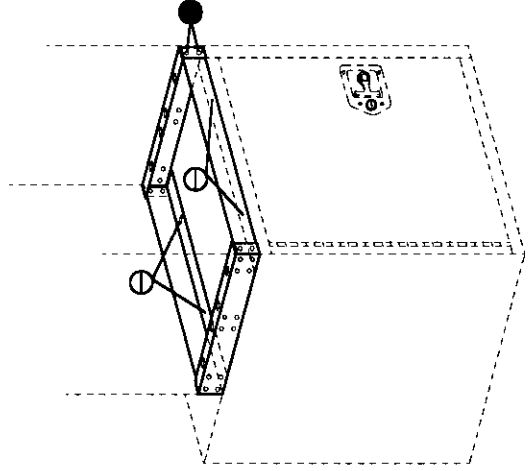
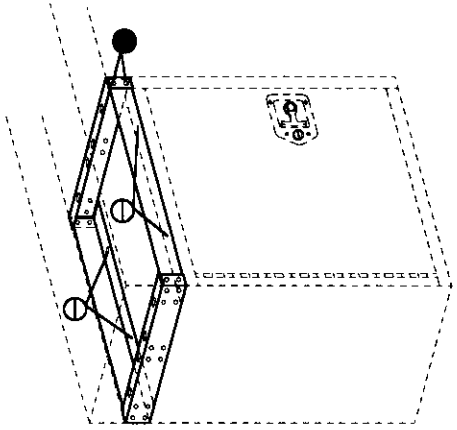
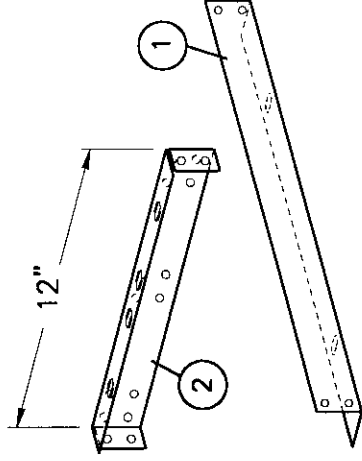
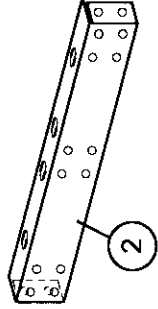
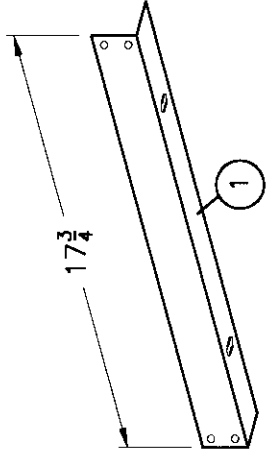

CAUTION:
DRILL THRU FLOOR WITH CARE
WATCH FOR GAS TANK, CONTROL
LINES, & ELECTRICAL WIRING.

FASTENING PROCEDURES
1. USE NUT & BOLT THRU WHEREVER POSSIBLE.
2. USE PLUSNUTS FOR BLIND FASTENING.
3. USE SHEET METAL SCREWS IN SHEAR ONLY.