



**ADRIAN STEEL®**

Cargo Management Solutions for Commercial Vehicles

## ***SF UNIT, T, 2T, 16X48X30, A, 3***

### *PRODUCT WEIGHT*

**79 lbs**

### *WIDTH X DEPTH X HEIGHT*

**48" X 16" X 30"**

### *CAPACITY*

**200 lbs per shelf**

### *COLOR*

**Gray with ASC  
Blue End Caps**

### *CATALOG NUMBER*

**PTSU2T164830A3**



### **PRODUCT FEATURES**

This shelving unit is made to be mounted to Extendedobed slide-outs. It is free standing and mounts using threaded inserts installed in the wood top. The front lips are 2 3/8" and the rear lips are 4 1/2". The shelving system is rated to 50 lbs/ft of shelving or 200 lbs for this 4 ft shelf.

This is a modular shelving kit made up of an end panel kit, an end cap kit, and a shelf kit.

SEE PAGE 2 FOR APPLICATION NOTES, ACCESSORIES AND OTHER PRODUCTS THAT WORK WITH THIS UNIT.

**SF UNIT, T, 2T, 16X48X30, A, 3**

**CATALOG NUMBER**  
**PTSU2T164830A3**

**PRODUCT APPLICATION**

**This free-standing shelving unit is designed to be mounted to Extendedbed slide-outs.**

**ACCESSORIES THAT WILL WORK WITH THIS PRODUCT**

<b>CATALOG NUMBER</b>	<b>DESCRIPTION (smart)</b>
WRH3	WIRE SPOOL HOLDER, 3-BAR
ACH3-8	AEROSOL CAN HLDR, LG 3-HL
1NTR	TANK HOLDER, NITROGEN

INSTR. : INS-PECK  
NUMBER

PG: 1  
REV: A

**NOTE: THIS INSTRUCTION IS  
VALID FOR THE FOLLOWING  
KITS:**

**TRUCK END CAP KITS**

- PECKT2T16A3
- PECKT2T16A1

**PECKT2T16A3**

ITEM NO.	PART NUMBER	DESCRIPTION	QTY.
1	PECT2T16L-A	END CAP,T,2T,16D,LEFT, A	2
2	PECT2T16R-A	END CAP,T,2T,16D,RIGHT, A	2
3	PEC2S10L-A	END CAP,2S,10D,LEFT, A	1
4	PEC2S10R-A	END CAP,2S,10D,RIGHT, A	1
5	BAGPECK2T3	BAG FOR BAGPECK2T3	1
6	INS-PECK	INSTALL INS FOR END CAP KITS	1

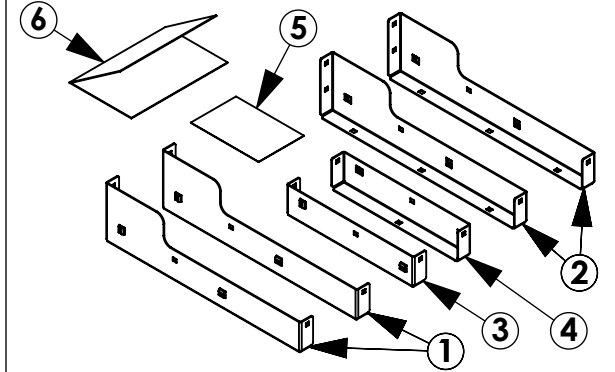

**PECKT2T16A1**

ITEM NO.	PART NUMBER	DESCRIPTION	QTY.
1	PECT2T16L-A	END CAP,T,2T,16D,LEFT, A	1
2	PECT2T16R-A	END CAP,T,2T,16D,RIGHT, A	1
3	BAGPECK2T1	BAG FOR BAGPECK2T1	1
4	INS-PECK	INSTALL INS FOR END CAP KITS	1

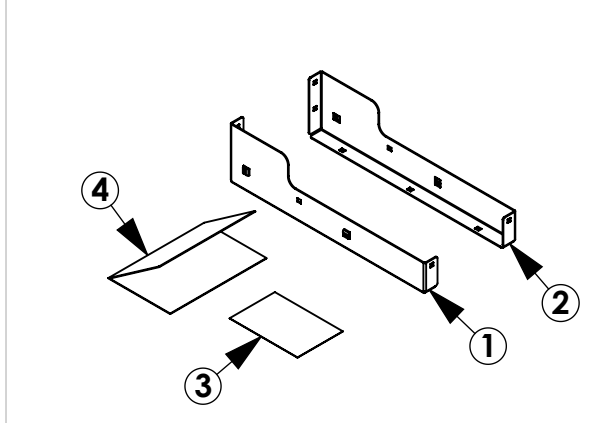

**TOOLS NEEDED:**

- 7/16" SOCKET
- TAPE MEASURE
- MARKER

**GET TO KNOW THE VEHICLE** - AT THE BEGINNING OF ANY INSTALLATION, CHECK THE LOCATION OF THE FUEL TANK, FUEL LINES, BRAKE LINES, HIGH VOLTAGE BATTERIES AND WIRING HARNESSSES TO AVOID INJURY OR PROPERTY DAMAGE FROM TOOL CONTACT.

**SEAL ALL EXTERIOR HOLES** - ALL INSTALLATION HOLES SHOULD BE SEALED WITH BUTYL TAPE OR SILICON TO PREVENT WATER AND EXHAUST GASES FROM ENTERING THE VEHICLE.

**CONTROL DRILL DEPTH** - TO AVOID DAMAGE TO THE VEHICLE, USE A DRILL STOP OR CLEARED STEP BIT WHEN DRILLING INSTALLATION HOLES.

**ALWAYS ADD PRIMER** - WHEN ADDING INSTALLATION HOLES BE SURE TO USE A SELF-ETCHING PRIMER TO PREVENT CORROSION, FASTENER FAILURE AND INJURY.

**MOUNTING POINTS MUST HAVE METAL-TO-METAL CONTACT** - USE PROVIDED MOUNTING SPACERS TO ACCOMMODATE FOR VEHICLE FEATURES, CARPET OR SUBFLOORS.

**PROVIDE CLEARANCE FOR SPACERS** - IF THE INSTALLATION VEHICLE CONTAINS A CARPET OR SUBFLOOR, USE A 1-3/16" DIAMETER CARPET CUTTER (P/N: 31183-0) AT ALL MOUNTING LOCATIONS TO OPEN UP ROOM FOR SPACERS.

**CHECK SPACER ORIENTATION** - BE SURE THAT THE INDENT IN THE SPACER COVERS THE PLUSNUT HEAD; THIS ENSURES THE MOST METAL-TO-METAL CONTACT AND REDUCES VIBRATION.

**PLUSNUT INSTALLATION** - A PLUSNUT GUN IS RECOMMENDED FOR PLUSNUT INSTALLATION FOR ITS PRODUCTION SPEED. HOWEVER, A PLUSNUT SETTING TOOL CAN ALSO BE USED (P/N: 22200-0).

**THRU-BOLT CLEARANCE** - WHEN USING A THRU-BOLT AT ANY MOUNTING LOCATION, BE SURE THAT YOUR HOLE HAS 1/16" CLEARANCE.

***FASTENERS USED***

***BAG REFERENCE:***

**BAGPECK2T3**

**THIS BAG IS FOR STANDARD 3 SHELF END CAP KITS**

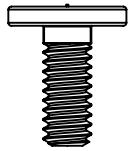
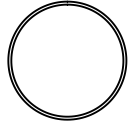

FAS0924  
BOLT,CRG 1/4-20X.62 FH  
QTY: 28

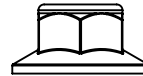
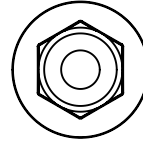

FAS0055  
NUT,HEX NLK FLG 1/4-20  
QTY: 28

**BAGPECK2T1**

**THIS BAG IS FOR A STANDARD 1 SHELF END CAP KIT**

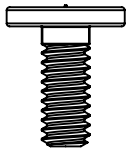
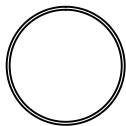

FAS0924  
BOLT,CRG 1/4-20X.62 FH  
QTY: 10

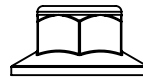
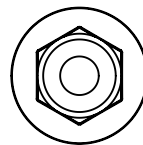

FAS0055  
NUT,HEX NLK FLG 1/4-20  
QTY: 10

**INTENTIONALLY LEFT BLANK**

**STEP 1 - MOUNT END CAPS TO END PANELS**

**Step 1.1**  
**SNAP END CAPS**  
**INTO LEFT END**  
**PANEL**  
**AND**  
**FULLY TIGHTEN**  
**FAS0924 AND**  
**FAS0055**  
**(3 PLACES)**  
**7/16" SOCKET**

**Step 1.2**  
**SNAP END CAPS**  
**INTO RIGHT END**  
**PANEL**  
**AND**  
**FULLY TIGHTEN**  
**FAS0924 AND**  
**FAS0055**  
**(3 PLACES)**  
**7/16" SOCKET**

**STANDARD TRUCK SHELF HEIGHTS**

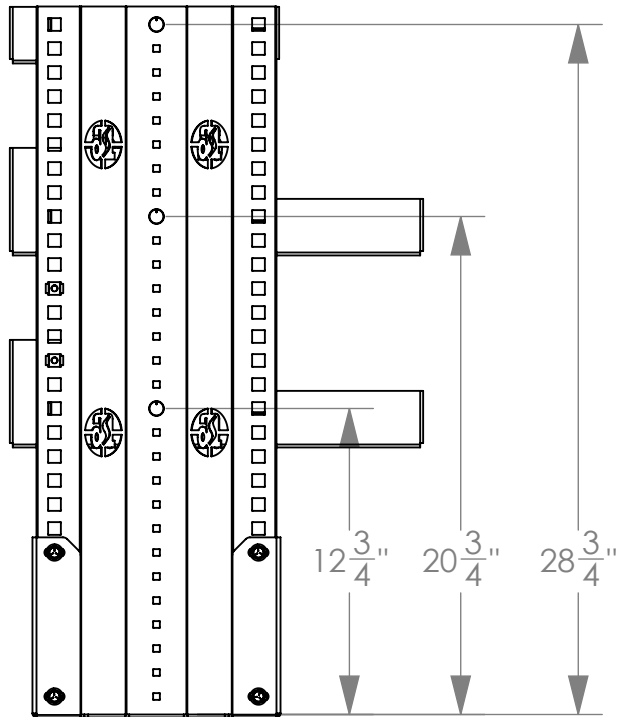

**CARRIAGE BOLT ON**  
**OUTSIDE OF END PANEL**

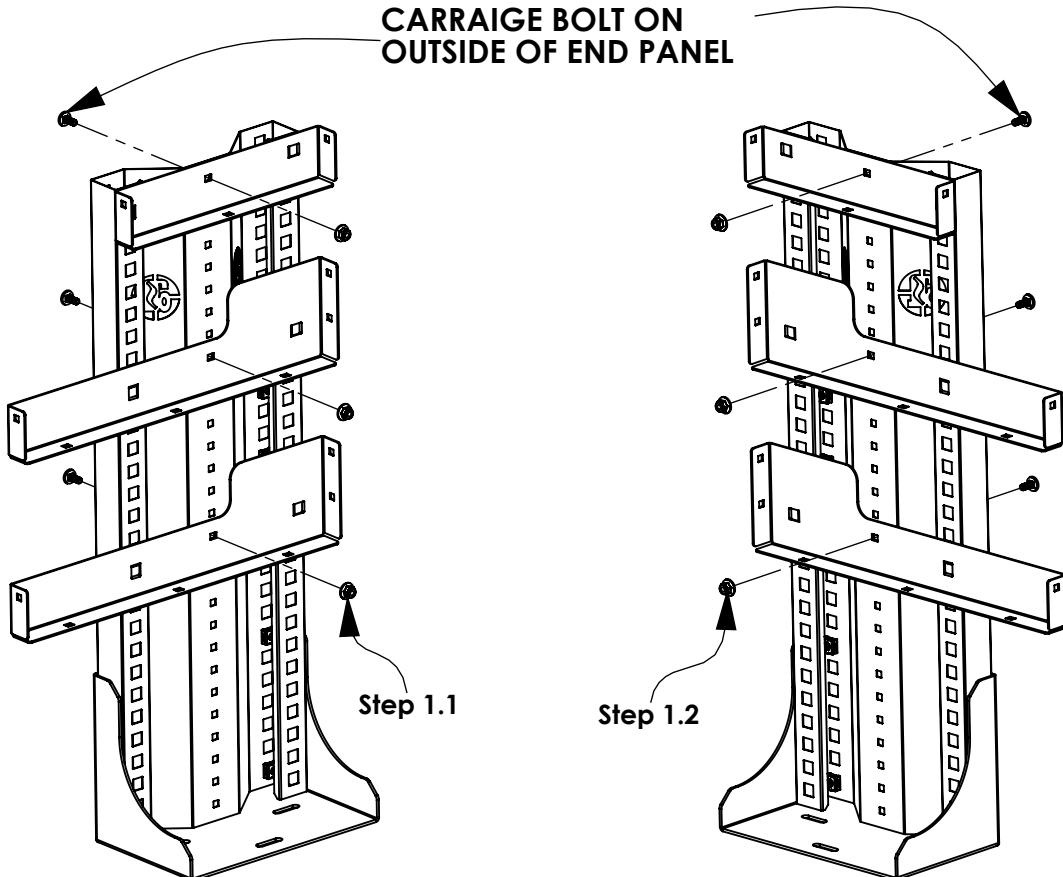

**STEP 2 - FASTEN SHELVES TO END CAPS**

**Step 2.1  
FASTEN SHELVES  
TO END CAPS  
AND  
FULLY TIGHTEN  
FAS0941 AND  
FAS0055  
(22 PLACES)  
7/16" SOCKET**

**Step 2.2  
FASTEN BRACES  
TO END PANEL  
FULLY TIGHTEN  
FAS0438  
(4 PLACES)  
1/2" SOCKET  
(FOUND IN END  
PANEL KIT)**

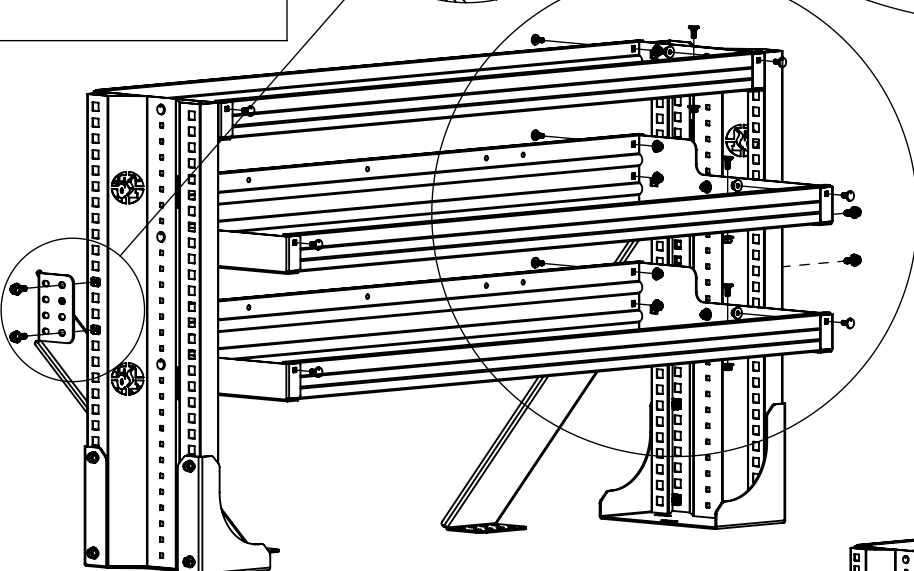
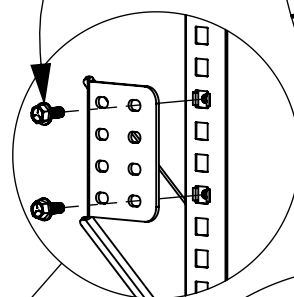
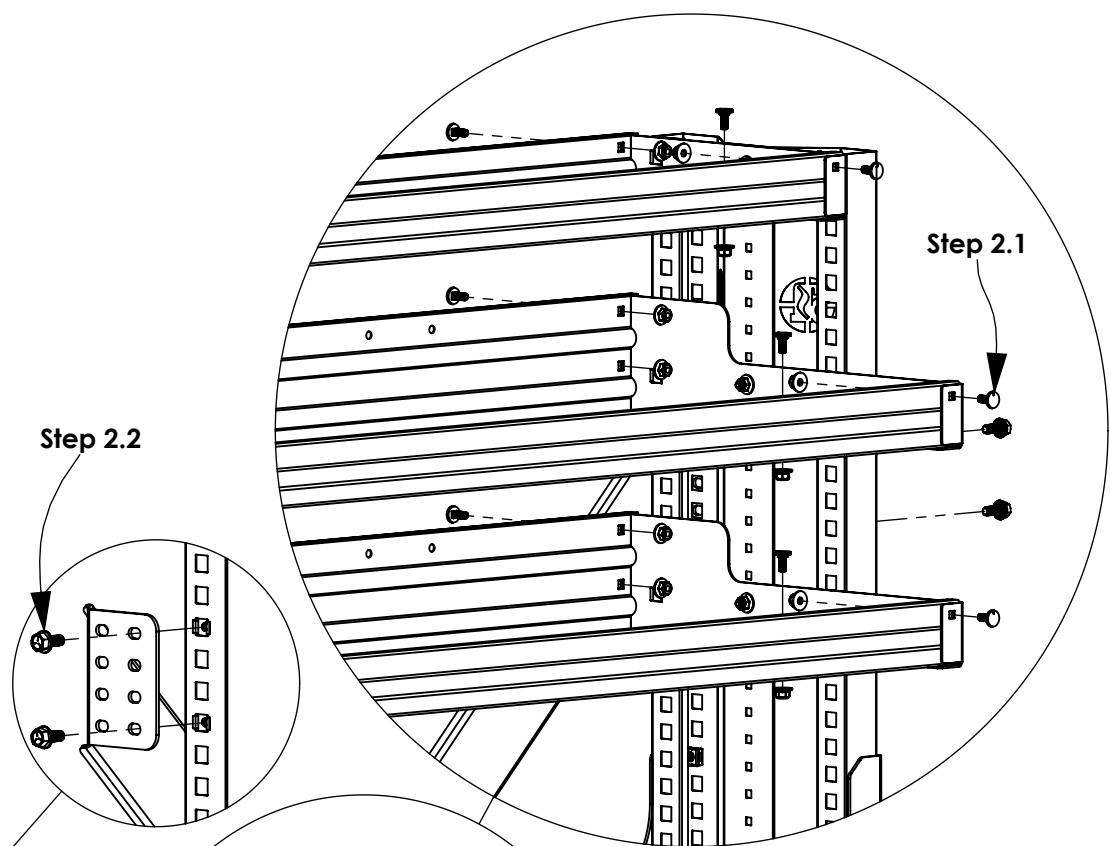

**COMPLETED VIEW**

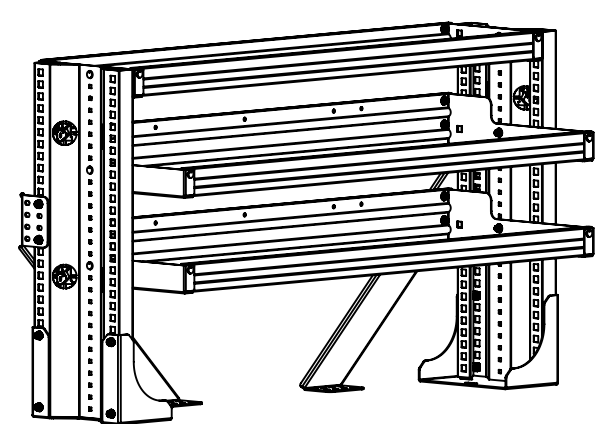

**AFTER COMPLETING STEP 2, RETURN TO  
INS-PEPK FOR MOUNTING INSTRUCTIONS.**

INSTR. NUMBER	PG:	REV:	ITEM NO.	PART NUMBER	DESCRIPTION	QTY.
: <b>INS-PEPK</b>	<b>1</b>	<b>B</b>	1	PEP1030-G	END PANEL,10X30, GRAY	2
			2	PEPFMB10-G	END PANEL,T,FLR MNT,10, GRAY	2
PART NUMBER : <b>PEPKT1030G</b>			3	PEPTB-G	END PANEL TRUCK BRACE, G	2
			4	BAGPEPKT	BAG FOR TRUCK END PANEL KITS	1
PART DESC. : END PANEL KIT,T,10X30,G			5	INS-PEPKT	INSTALL INSTRUCTIONS FOR PEPKT	1

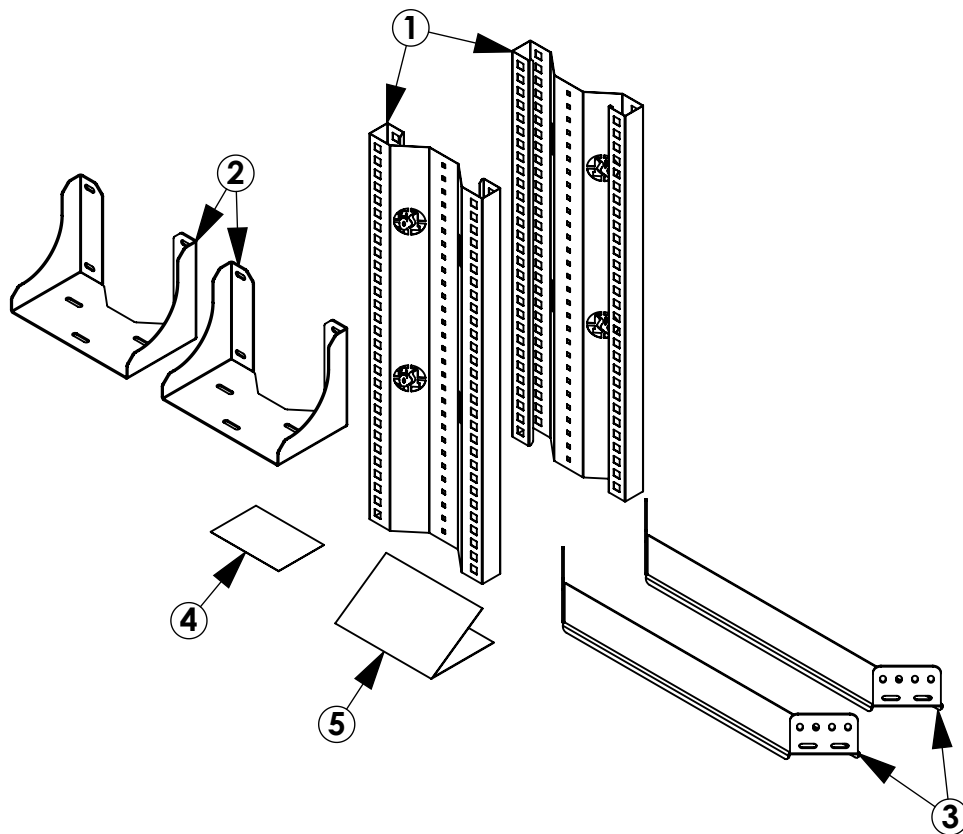

**TOOLS NEEDED:**

- 1/2" Socket
- 8mm ALLEN BIT
- DRILL
- 7/16" DRILL BIT
- MARKER

**GET TO KNOW THE VEHICLE** - AT THE BEGINNING OF ANY INSTALLATION, CHECK THE LOCATION OF THE FUEL TANK, FUEL LINES, BRAKE LINES, HIGH VOLTAGE BATTERIES AND WIRING HARNESES TO AVOID INJURY OR PROPERTY DAMAGE FROM TOOL CONTACT.

**SEAL ALL EXTERIOR HOLES** - ALL INSTALLATION HOLES SHOULD BE SEALED WITH BUTYL TAPE OR SILICON TO PREVENT WATER AND EXHAUST GASES FROM ENTERING THE VEHICLE.

**CONTROL DRILL DEPTH** - TO AVOID DAMAGE TO THE VEHICLE, USE A DRILL STOP OR CLEARED STEP BIT WHEN DRILLING INSTALLATION HOLES.

**ALWAYS ADD PRIMER** - WHEN ADDING INSTALLATION HOLES BE SURE TO USE A SELF-ETCHING PRIMER TO PREVENT CORROSION, FASTENER FAILURE AND INJURY.

**MOUNTING POINTS MUST HAVE METAL-TO-METAL CONTACT** - USE PROVIDED MOUNTING SPACERS TO ACCOMMODATE FOR VEHICLE FEATURES, CARPET OR SUBFLOORS.

**PROVIDE CLEARANCE FOR SPACERS** - IF THE INSTALLATION VEHICLE CONTAINS A CARPET OR SUBFLOOR, USE A 1-3/16" DIAMETER CARPET CUTTER (P/N: 31183-0) AT ALL MOUNTING LOCATIONS TO OPEN UP ROOM FOR SPACERS.

**CHECK SPACER ORIENTATION** - BE SURE THAT THE INDENT IN THE SPACER COVERS THE PLUSNUT HEAD; THIS ENSURES THE MOST METAL-TO-METAL CONTACT AND REDUCES VIBRATION.

**PLUSNUT INSTALLATION** - A PLUSNUT GUN IS RECOMMENDED FOR PLUSNUT INSTALLATION FOR ITS PRODUCTION SPEED. HOWEVER, A PLUSNUT SETTING TOOL CAN ALSO BE USED (P/N: 22200-0).

**THRU-BOLT CLEARANCE** - WHEN USING A THRU-BOLT AT ANY MOUNTING LOCATION, BE SURE THAT YOUR HOLE HAS 1/16" CLEARANCE.

**FASTENERS USED**

**BAG REFERENCE: BAGPEPKT**

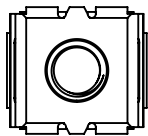

FAS-SQR  
CAGE NUT, 5/16-18  
QTY: 12

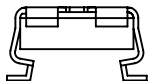

FAS0921  
5/16-18 THREADED INSERT.  
QTY: 10



FAS0438  
SCREW, HFLNG 5/16-18X.75  
QTY: 12

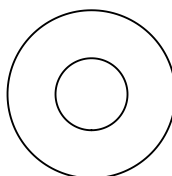
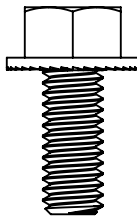

FAS0086  
WASHER, FLAT USS 5/16  
QTY: 10

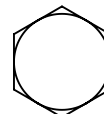

FAS0081  
SCREW, HH 5/16-18X.75.  
QTY: 10

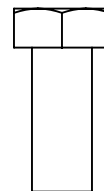

FAS0098  
WASHER, LCK SPLIT 5/16  
QTY: 10

**INTENTIONALLY LEFT BLANK**

**STEP 1 - MOUNT FLOOR MOUNTS TO END PANELS**

**Step 1.1**

**INSTALL  
FAS0915 ON  
THE OUTER  
FACE OF THE  
END PANEL**

**Step 1.3**

**FULLY TIGHTEN**

**FAS0438  
(4 PLACES)  
1/2" SOCKET**

**STEP 1.1  
BOTH END PANELS**

**(4) PLACES TOTAL**

**THESE WILL BE USED  
TO MOUNT BRACES**

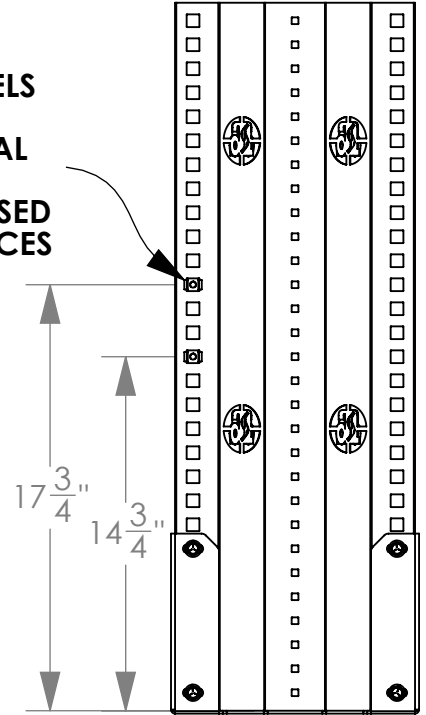

**STEP 1.2**

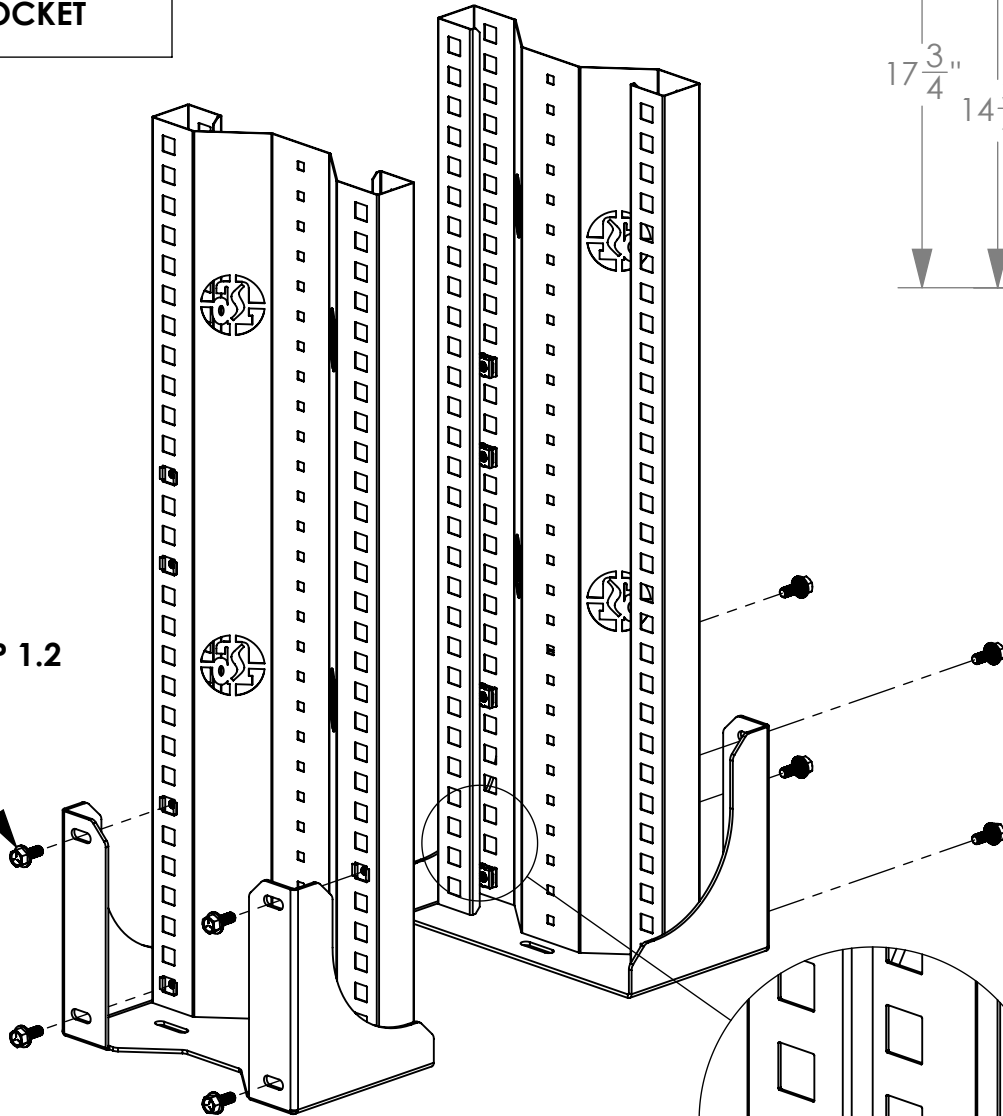

**SNAP FAS0915  
INTO END PANEL  
(8 PLACES)**



**REFERENCE: GO TO INS-PECK FOR END CAP AND SHELF MOUNTING INSTRUCTIONS**

**STEP 2 - MOUNT ASSEMBLED SHELVING UNIT TO EXTENDEBED**

**Step 2.1**

**MARK AND DRILL HOLES USING A 7/16" DRILL BIT (10 PLACES)**

**Step 2.2**

**FULLY TIGHTEN FAS0086, FAS0098, FAS0081, AND FAS0921 (10 PLACES PER UNIT) 1/2" SOCKET**

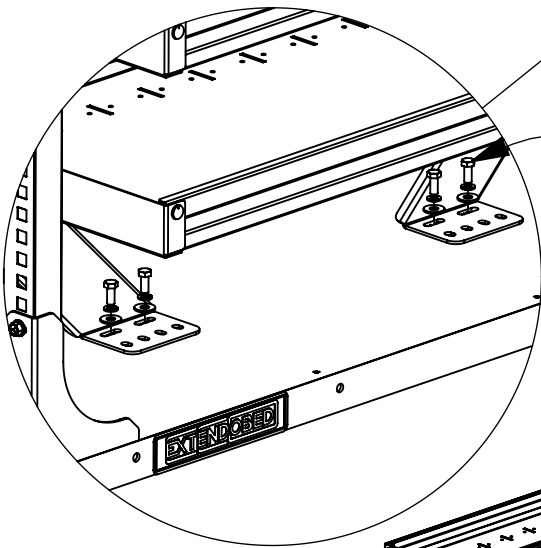
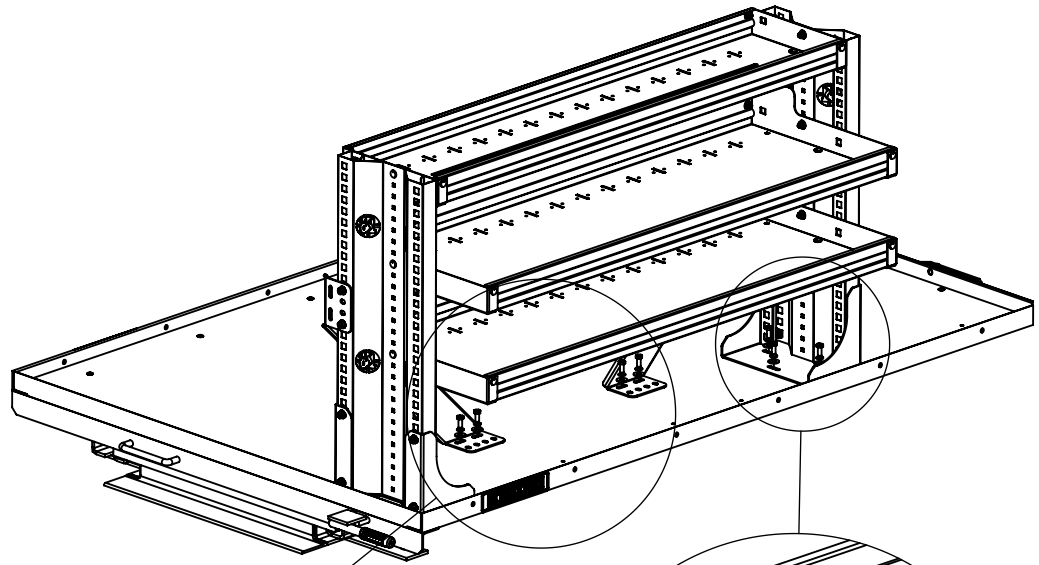

**STEP 2.2**

