

**PRODUCT WEIGHT**  
**12.35 LBS**

**WIDTH x DEPTH x HEIGHT**  
**44.07" x 8.25" x 4.62"**

**CAPACITY**  
**150 LBS**

**COLOR**  
**GRAY**

**CATALOG NUMBER**  
**PT44**

**PRODUCT FEATURES**

Pipe tray with 44" span for use in 16" shelving

**SEE PAGE 2 FOR APPLICATION NOTES AND ACCESSORIES, OTHER PRODUCTS THAT WORK WITH THIS UNIT.**



**CATALOG NUMBER     **PT44****

***PRODUCT APPLICATION***

**This product is designed to be installed on 44” span shelves that mount to 16” shelving end panels.**

***ACCESSORIES THAT WILL WORK WITH THIS PRODUCT***

<b><i>CATALOG NUMBER</i></b>	<b><i>DESCRIPTION</i></b>
<b>HD-1644GM</b>	<b>16" SHELVING, 44" WIDTH GM</b>
<b>HD-1644GMC</b>	<b>16" SHELVING, 44" WIDTH GM, WITH CONDUIT</b>
<b>HD-1644HR</b>	<b>16” SHELVING, 44” WIDTH FTMH/SPR</b>
<b>HD-1644HRC</b>	<b>16” SHELVING, 44” WIDTH FTMH/SPR WITH CONDUIT</b>
<b>HD-1644TL</b>	<b>16" SHELVING, 44" WIDTH TRANSIT LOW ROOF</b>
<b>HD-1644TLC</b>	<b>16" SHELVING, 44" WIDTH TRANST LOW ROOF WITH CONDUIT</b>

***SPECIAL APPLICATION NOTES***

INSTR. NUMBER	PG:	REV:	ITEM NO.	PART NUMBER	DESCRIPTION	QTY.
: PT32	1	A	1	CRT67171	CARTON FOR 32" PIPE TRAY	1
			2	66486-G	PIPE TRAY 32", GRAY	1
PART NUMBER : PT32			3	BAG66986	FAS BAG 16 IN SHELVING ACCESSORIES	1
	PART DESC. : PIPE TRAY KIT 32"		4	66985	INS FOR LOW ROOF 16 IN SHELVING accessories	1

**THIS INSTRUCTION IS FOR ALL SHELVING VARIATIONS OF THE PIPE TRAYS AND 8" DEEP SHELVES THAT WORK WITH 16" DEEP SHELVING. THIS INCLUDES 32" (PT32 SHOWN BELOW), 40", 44", 50", AND 60". THE INSTALLATION OF THESE SHELVES IS NOT DEPENDANT ON THE SHELF LENGTH OR IF THE END PANELS HAVE THE CONDUIT CARRIER ACCESS HOLE. SEE PAGE 3 & 4 FOR A BREAKDOWN OF ALTERNATE SHELVING ACCESSORIES.**

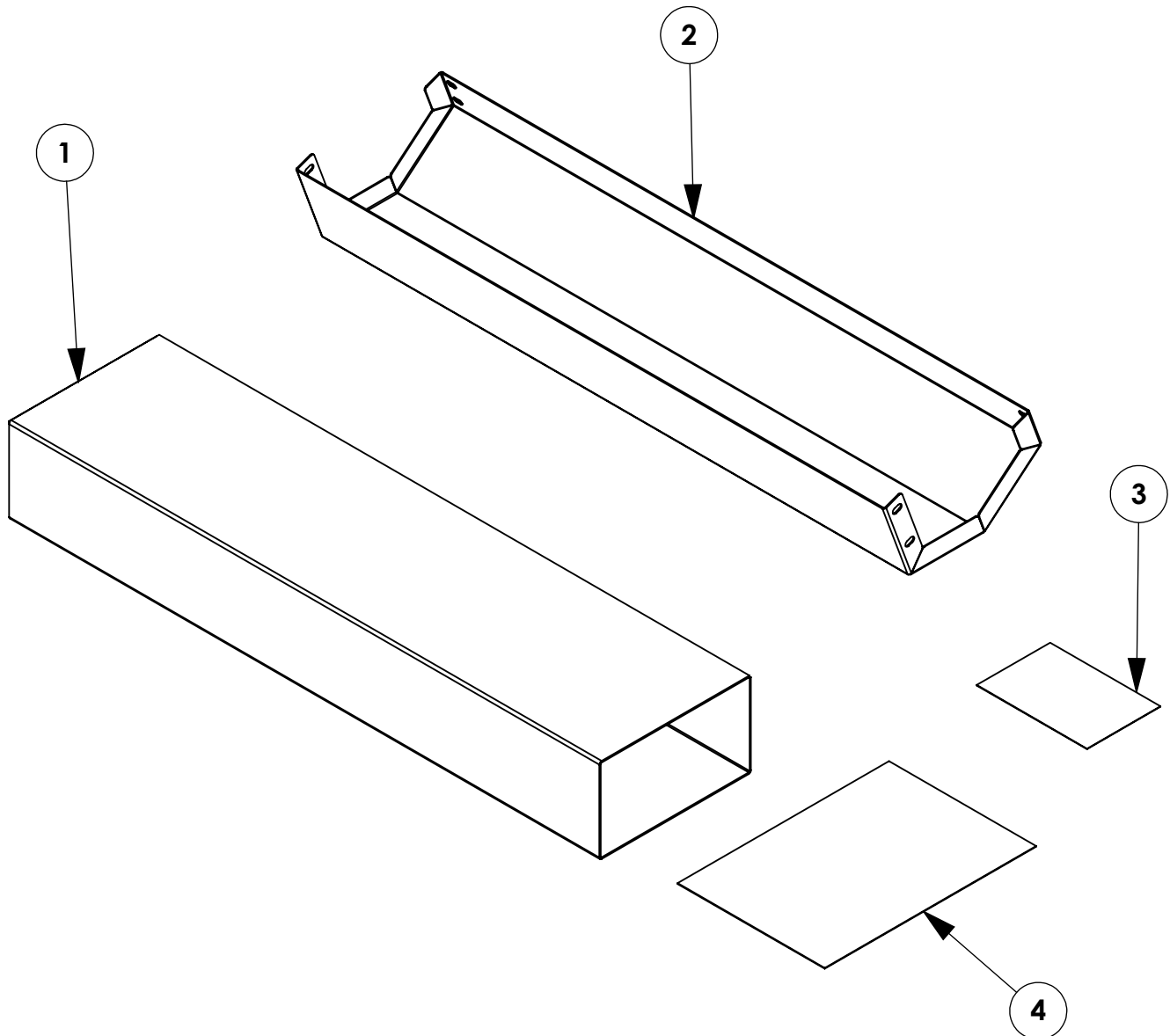

**GET TO KNOW THE VEHICLE** - AT THE BEGINNING OF ANY INSTALLATION, CHECK THE LOCATION OF THE FUEL TANK, FUEL LINES, BRAKE LINES, HIGH VOLTAGE BATTERIES AND WIRING HARNESSSES TO AVOID INJURY OR PROPERTY DAMAGE FROM TOOL CONTACT.

**SEAL ALL EXTERIOR HOLES** - ALL INSTALLATION HOLES SHOULD BE SEALED WITH BUTYL TAPE OR SILICON TO PREVENT WATER AND EXHAUST GASES FROM ENTERING THE VEHICLE.

**CONTROL DRILL DEPTH** - TO AVOID DAMAGE TO THE VEHICLE, USE A DRILL STOP OR CLEARED STEP BIT WHEN DRILLING INSTALLATION HOLES.

**ALWAYS ADD PRIMER** - WHEN ADDING INSTALLATION HOLES BE SURE TO USE A SELF-ETCHING PRIMER TO PREVENT CORROSION, FASTENER FAILURE AND INJURY.

**MOUNTING POINTS MUST HAVE METAL-TO-METAL CONTACT** - USE PROVIDED MOUNTING SPACERS TO ACCOMMODATE FOR VEHICLE FEATURES, CARPET OR SUBFLOORS.

**PROVIDE CLEARANCE FOR SPACERS** - IF THE INSTALLATION VEHICLE CONTAINS A CARPET OR SUBFLOOR, USE A 1-3/16" DIAMETER CARPET CUTTER (P/N: 31183-0) AT ALL MOUNTING LOCATIONS TO OPEN UP ROOM FOR SPACERS.

**CHECK SPACER ORIENTATION** - BE SURE THAT THE INDENT IN THE SPACER COVERS THE PLUSNUT HEAD; THIS ENSURES THE MOST METAL-TO-METAL CONTACT AND REDUCES VIBRATION.

**PLUSNUT INSTALLATION** - A PLUSNUT GUN IS RECOMMENDED FOR PLUSNUT INSTALLATION FOR ITS PRODUCTION SPEED. HOWEVER, A PLUSNUT SETTING TOOL CAN ALSO BE USED (P/N: 22200-0).

**THRU-BOLT CLEARANCE** - WHEN USING A THRU-BOLT AT ANY MOUNTING LOCATION, BE SURE THAT YOUR HOLE HAS 1/16" CLEARANCE.

**ADDITIONAL SHELVING ACCESSORY OPTIONS****PT32**

ITEM NO.	PART NUMBER	DESCRIPTION	QTY.
1	CRT67171	CARTON FOR 32" PIPE TRAY	1
2	66486-G	PIPE TRAY 32", GRAY	1
3	BAG66986	FAS BAG 16 IN SHELVING ACCESSORIES	1
4	66985	INS FOR LOW ROOF 16 IN SHELVING accessories	1

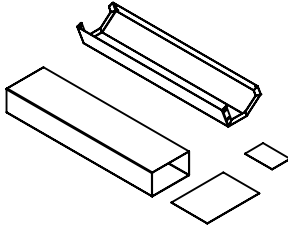
**PT40**

ITEM NO.	PART NUMBER	DESCRIPTION	QTY.
1	CRT67172	CARTON FOR 40" PIPE TRAY	1
2	67166-G	PIPE TRAY 40", GRAY	1
3	BAG66986	FAS BAG 16 IN SHELVING ACCESSORIES	1
4	66985	INS FOR LOW ROOF 16 IN SHELVING accessories	1

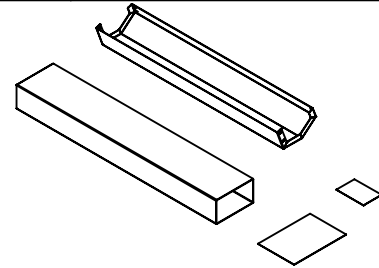
**PT44**

ITEM NO.	PART NUMBER	DESCRIPTION	QTY.
1	CRT67172	CARTON FOR 40" PIPE TRAY	1
2	66485-G	PIPE TRAY 44", GRAY	1
3	BAG66986	FAS BAG 16 IN SHELVING ACCESSORIES	1
4	66985	INS FOR LOW ROOF 16 IN SHELVING accessories	1

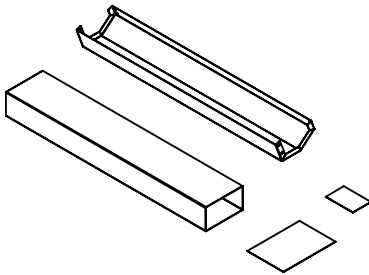
**PT50**

ITEM NO.	PART NUMBER	DESCRIPTION	QTY.
1	CRT67173	CARTON FOR 50" PIPE TRAY	1
2	66484-G	PIPE TRAY 50", GRAY	1
3	BAG66986	FAS BAG 16 IN SHELVING ACCESSORIES	1
4	66985	INS FOR LOW ROOF 16 IN SHELVING accessories	1

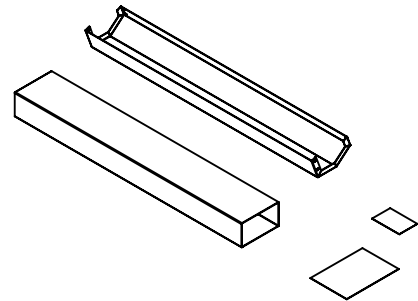
**PT60**

ITEM NO.	PART NUMBER	DESCRIPTION	QTY.
1	CRT67174	CARTON FOR 60" PIPE TRAY	1
2	66483-G	PIPE TRAY 60", GRAY	1
3	BAG66986	FAS BAG 16 IN SHELVING ACCESSORIES	1
4	66985	INS FOR LOW ROOF 16 IN SHELVING accessories	1

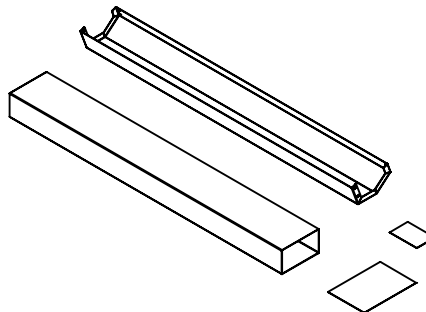

**ADDITIONAL SHELVING ACCESSORY OPTIONS****SF20832XCK**

ITEM NO.	PART NUMBER	DESCRIPTION	QTY.
1	CRT67175	CARTON FOR 32" X 8" SHELF	1
2	66985	INS FOR LOW ROOF 16 IN SHELVING accessories	1
3	SF20832-G	SHELF, STD, 2X08X32, GRAY	1
4	BAG66986	FAS BAG 16 IN SHELVING ACCESSORIES	1

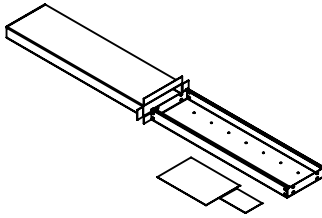
**SF20840XCK**

ITEM NO.	PART NUMBER	DESCRIPTION	QTY.
1	CRT67176	CARTON FOR 44" X 8" LR SHELVING	1
2	66985	INS FOR LOW ROOF 16 IN SHELVING accessories	1
3	SF20840X	SHELF, STD, 2X08X40	1
4	BAG66986	FAS BAG 16 IN SHELVING ACCESSORIES	1

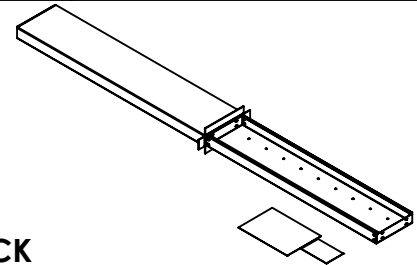
**SF20844XCK**

ITEM NO.	PART NUMBER	DESCRIPTION	QTY.
1	CRT67176	CARTON FOR 44" X 8" LR SHELVING	1
2	66985	INS FOR LOW ROOF 16 IN SHELVING accessories	1
3	SF20844-G	SHELF, STD, 2X08X44, GRAY	1
4	BAG66986	FAS BAG 16 IN SHELVING ACCESSORIES	1

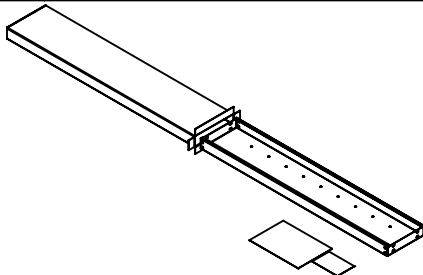
**SF20850XCK**

ITEM NO.	PART NUMBER	DESCRIPTION	QTY.
1	CRT67177	CARTON FOR 50" X 8" SHELF	1
2	66985	INS FOR LOW ROOF 16 IN SHELVING accessories	1
3	SF20850X-G	SHELF, STD, 2X08X50, GRAY	1
4	BAG66986	FAS BAG 16 IN SHELVING ACCESSORIES	1

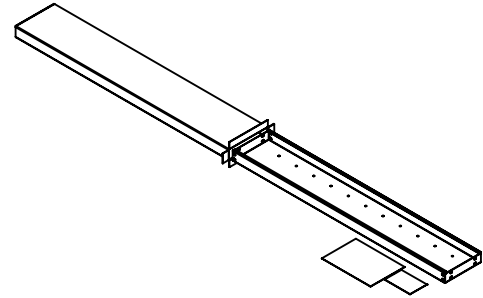
**SF20860XCK**

ITEM NO.	PART NUMBER	DESCRIPTION	QTY.
1	CRT67178	CARTON FOR 60" X 8" SHELF	1
2	66985	INS FOR LOW ROOF 16 IN SHELVING accessories	1
3	SF20860X-G	SHELF, STD, 2X08X60, GRAY	1
4	BAG66986	FAS BAG 16 IN SHELVING ACCESSORIES	1

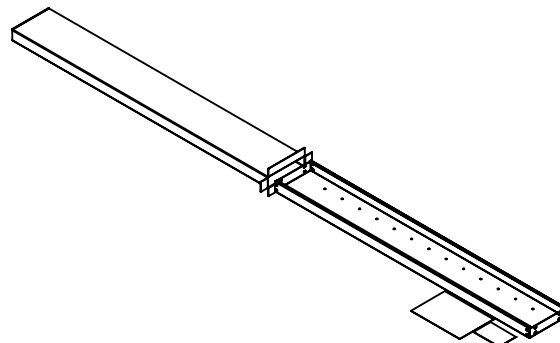

***FASTENERS USED***

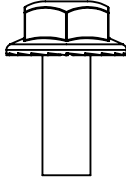

FAS0018  
SCREW, HFLNG 1/4-20X.62  
QTY: 8

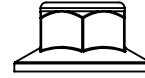

FAS0055  
NUT, HEX NLK FLG 1/4-20  
QTY: 8

**BEGIN ASSEMBLY**

**STEP 1 - BOLT SHELVING TO END PANELS THROUGH FRONT FLANGE ON BOTH SIDES**

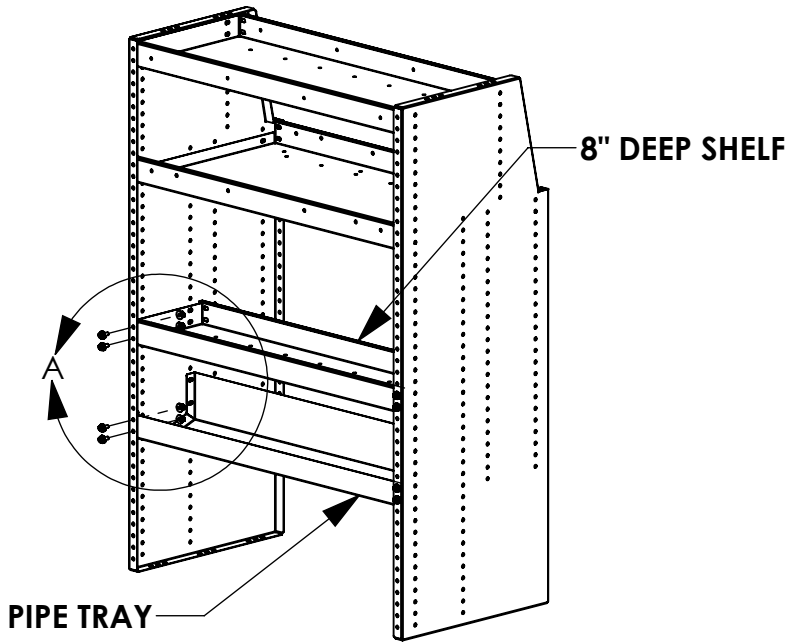

USE FAS0018 AND FAS0055  
(4 PLACES)  
1/2 WRENCH  
1/2 SOCKET

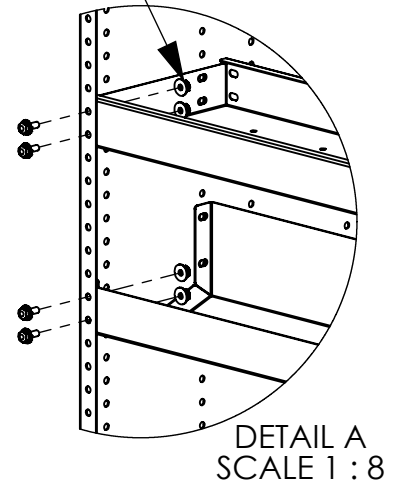

**STEP 2 - BOLT SHELVING TO END PANELS THROUGH SIDE HOLES THAT ALIGN WITH SHELVE'S MOUNTING SLOTS.**

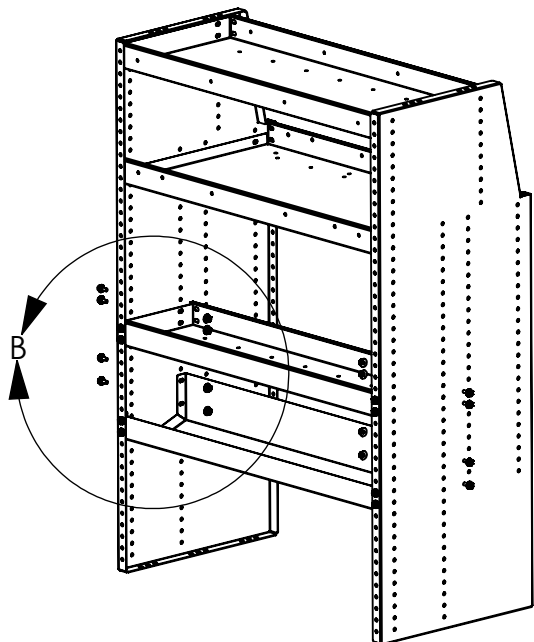

USE FAS0018 AND FAS0055  
(4 PLACES)  
1/2 WRENCH  
1/2 SOCKET

