

INSTR. NUMBER : 67116	PG: 1	REV: C	ITEM NO.	PART NUMBER	DESCRIPTION	GL-FSVDS	GL-FSVPS
PART NUMBER • <b>GL-FSVDS</b> PART NUMBER • <b>GL-FSVPS</b>			1	66358	GRIP LOCK FRONT STOP ASSM	1	1
			2	27254-B	SLEEVE-HORN,L.R. BLACK	1	1
PART • <b>GL FULL SIZE VEHICLE DS</b> DESC. • <b>GL FULL SIZE VEHICLE PS</b>			3	66293	GRIP LOCK OUTER TUBE	1	1
			4	66357	GRIP LOCK HANDLE CLAMP POST	1	1
<b>NOTE: THIS INSTRUCTION IS VALID FOR THE FOLLOWING KITS:</b>			5	69445	GRIP LOCK FSV, ASM DS	1	-
			6	69444	GRIP LOCK FSV, ASM PS	-	1

**NOTE: 66357, 69444, & 69445 ARE AVAILABLE IN BLACK VARIANTS - FOR THEIR IDENTIFICATION, ADD THE "-B" SUFFIX TO THE END OF THE PART NUMBER**

- GL-FSVDS
- GL-FSVPS
- GL-FSVPSB
- GL-FSVDSB

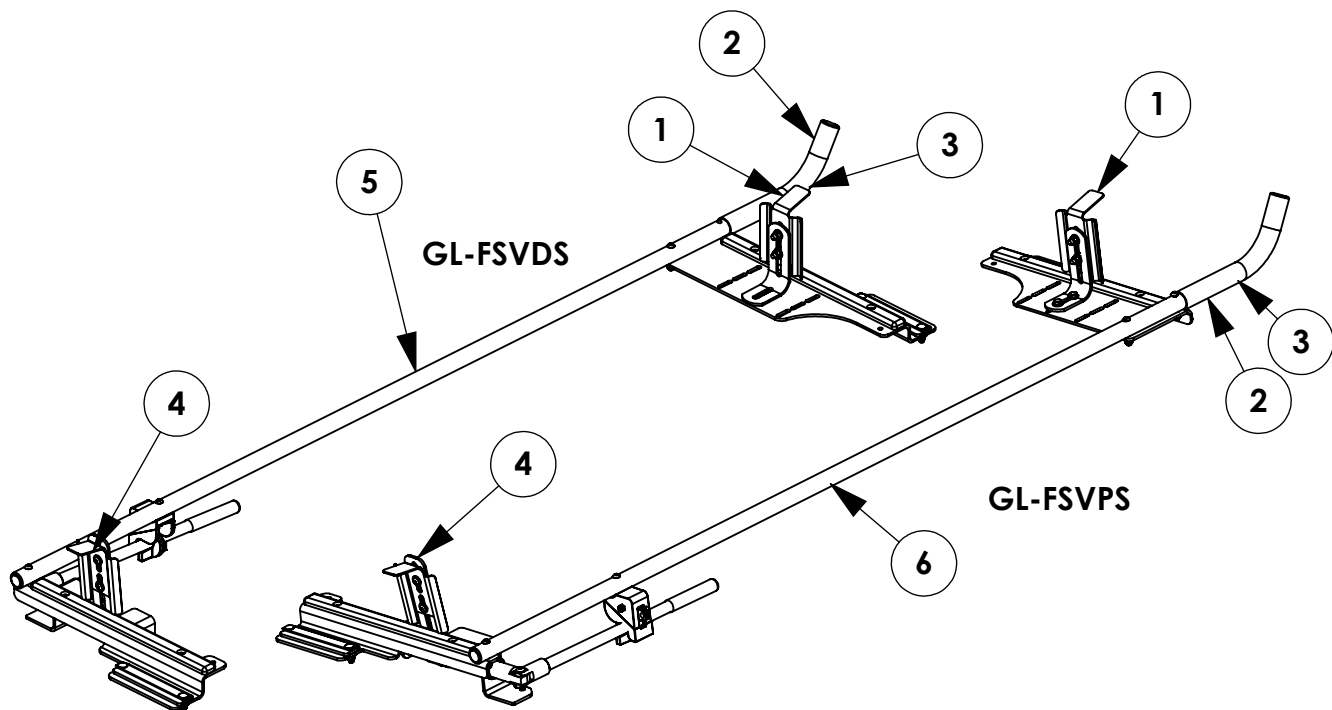

**\*\*IF BUILDING A DUAL SIDED RACK BUILD BOTH SIDES IN PARALLEL FOR EACH STEP. IF BUILDING SINGLE SIDED REFERENCE ONLY THAT SIDE WHEN BUILDING.\*\***

**TOOLS NEEDED:**  
 1/2" SOCKET  
 1/2" WRENCH  
 9/16" SOCKET  
 3/16" ALLEN WRENCH  
 DRIVE RATCHET  
 IMPACT DRIVER

**GET TO KNOW THE VEHICLE** - AT THE BEGINNING OF ANY INSTALLATION, CHECK THE LOCATION OF THE FUEL TANK, FUEL LINES, BRAKE LINES, HIGH VOLTAGE BATTERIES AND WIRING HARNESSSES TO AVOID INJURY OR PROPERTY DAMAGE FROM TOOL CONTACT.

**SEAL ALL EXTERIOR HOLES** - ALL INSTALLATION HOLES SHOULD BE SEALED WITH BUTYL TAPE OR SILICON TO PREVENT WATER AND EXHAUST GASES FROM ENTERING THE VEHICLE.

**CONTROL DRILL DEPTH** - TO AVOID DAMAGE TO THE VEHICLE, USE A DRILL STOP OR CLEARED STEP BIT WHEN DRILLING INSTALLATION HOLES.

**ALWAYS ADD PRIMER** - WHEN ADDING INSTALLATION HOLES BE SURE TO USE A SELF-ETCHING PRIMER TO PREVENT CORROSION, FASTENER FAILURE AND INJURY.

**MOUNTING POINTS MUST HAVE METAL-TO-METAL CONTACT** - USE PROVIDED MOUNTING SPACERS TO ACCOMMODATE FOR VEHICLE FEATURES, CARPET OR SUBFLOORS.

**PROVIDE CLEARANCE FOR SPACERS** - IF THE INSTALLATION VEHICLE CONTAINS A CARPET OR SUBFLOOR, USE A 1-3/16" DIAMETER CARPET CUTTER (P/N: 31183-0) AT ALL MOUNTING LOCATIONS TO OPEN UP ROOM FOR SPACERS.

**CHECK SPACER ORIENTATION** - BE SURE THAT THE INDENT IN THE SPACER COVERS THE PLUSNUT HEAD; THIS ENSURES THE MOST METAL-TO-METAL CONTACT AND REDUCES VIBRATION.

**PLUSNUT INSTALLATION** - A PLUSNUT GUN IS RECOMMENDED FOR PLUSNUT INSTALLATION FOR ITS PRODUCTION SPEED. HOWEVER, A PLUSNUT SETTING TOOL CAN ALSO BE USED (P/N: 22200-0).

**THRU-BOLT CLEARANCE** - WHEN USING A THRU-BOLT AT ANY MOUNTING LOCATION, BE SURE THAT YOUR HOLE HAS 1/16" CLEARANCE.

**FASTENERS USED**

**BAG REFERENCE: BAG66374**

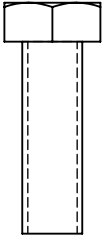

FAS0597  
SCREW, HH SS  
5/16-18X1.00  
SINGLE QTY: 2

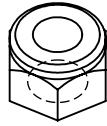

FAS0248  
NUT, HEX NLK  
5/16-18 SS  
SINGLE QTY: 3

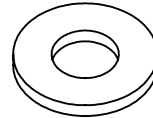

FAS0552  
WASHER, FLAT  
5/16 USS SS  
SINGLE QTY: 5

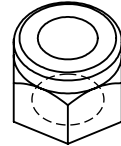

FAS0110  
NUT, HEX NLK  
3/8-16 SS  
QTY: 1

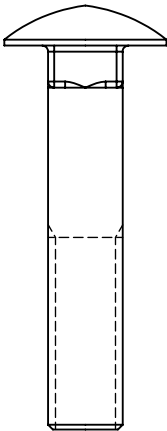

FAS0721  
BOLT, CRG SS  
3/8-16X2.00  
QTY: 1

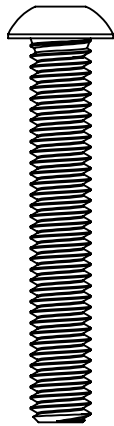

FAS0841  
SCRW, BHCS SS  
5/16-18X2.0  
QTY: 1

**FOR DUAL SIDED RACK DOUBLE FASTENER QUANTITY**

**INTENTIONALLY LEFT BLANK**



# SHIP THRU FINAL DEALER ASSEMBLY

IF NOT RECEIVING SHIP THRU RACK SKIP TO STEP 2

## STEP 1 SLIDE RACK OUT FROM SHIP THRU MODE

STEP 1.1  
LOOSEN FAS0248  
(04 PLACES PER SIDE)  
1/2" WRENCH

STEP 1.2  
SLIDE RACK  
OUTWARDS UNTIL  
GRIP LOCK  
TOUCHES  
MOUNTING FEET

STEP 1.3  
FULLY TIGHTEN  
FAS0248  
(04 PLACES PER SIDE)  
1/2" WRENCH

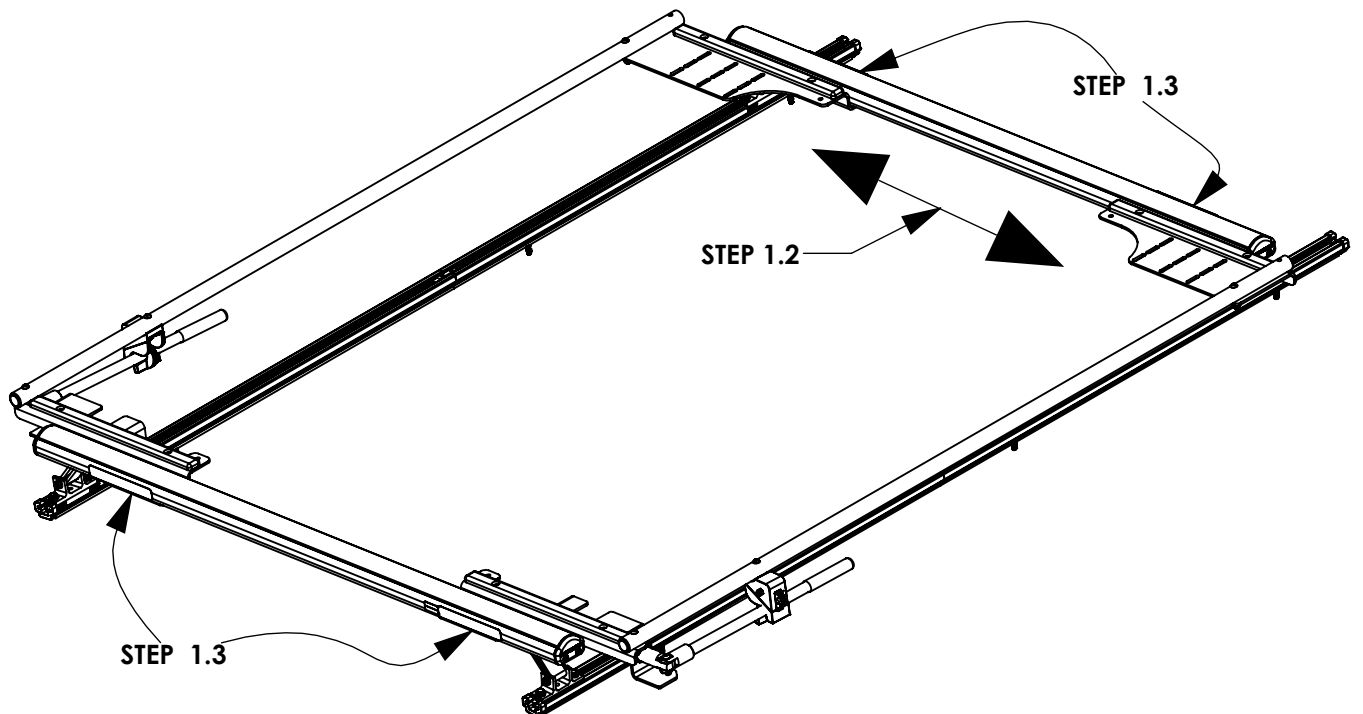
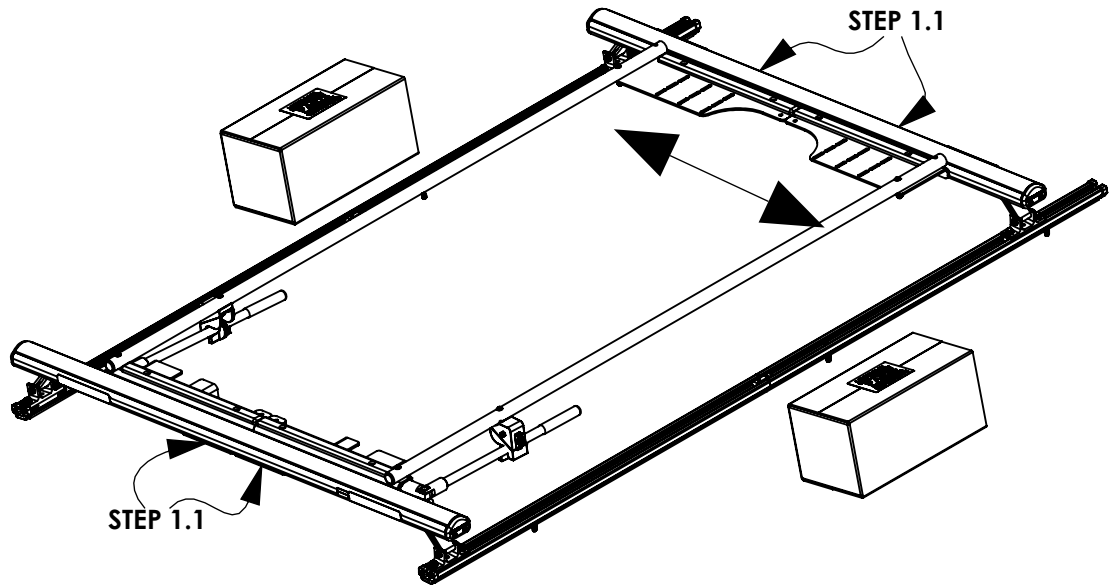

**STEP 2 -ASSEMBLE HANDLE POST TO REAR BRACE ASSEMBLY**

**STEP 2.1**  
**FULLY TIGHTEN**  
**FAS0721 AND**  
**FAS0110**  
**9/16" WRENCH**

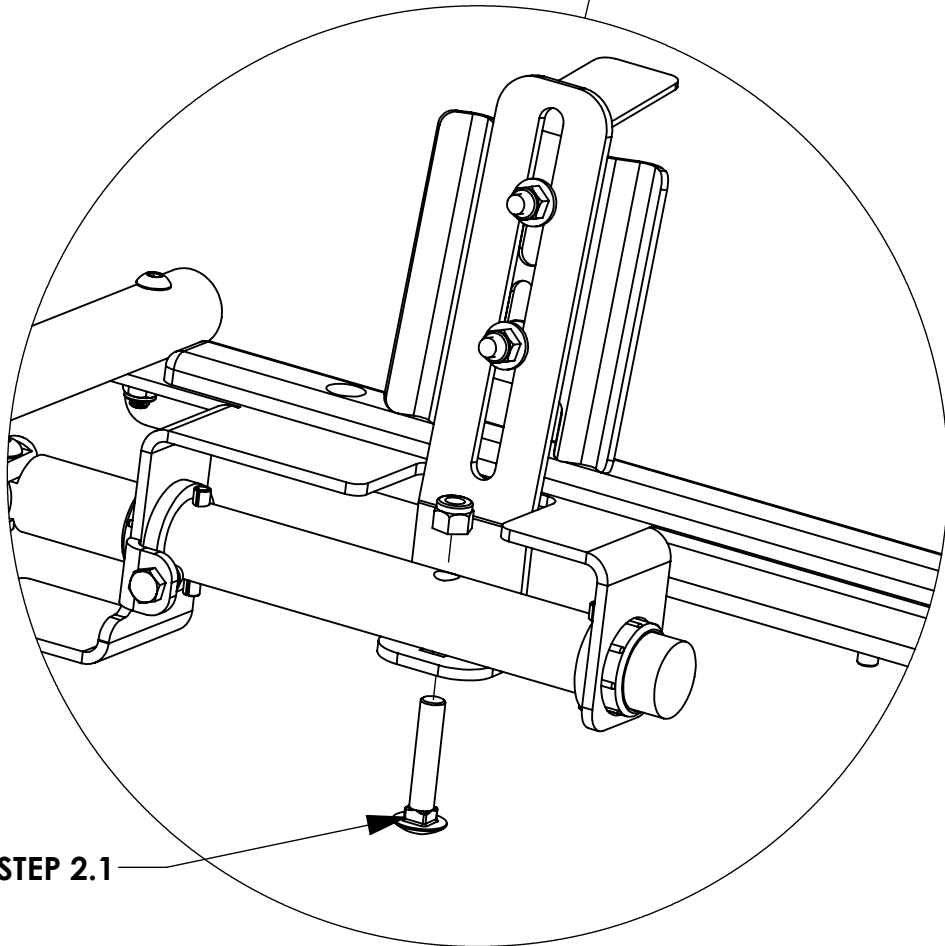
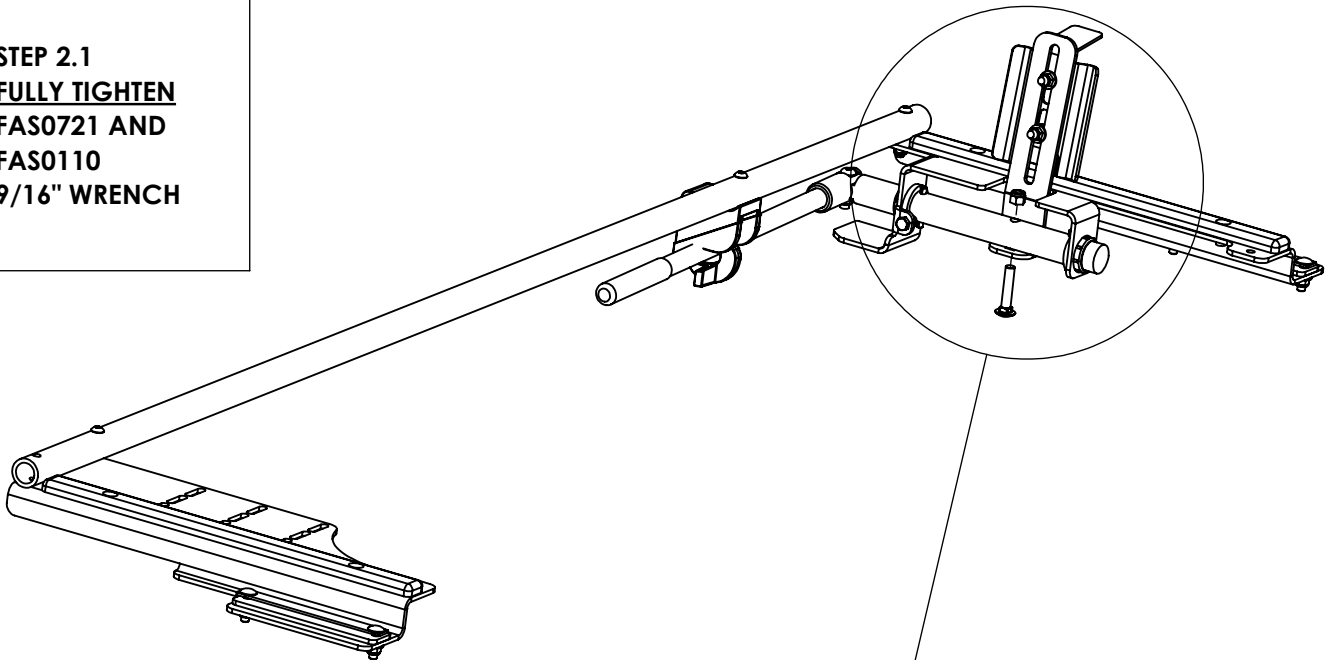

**STEP 2.1**

# STEP 3 - ASSEMBLE FRONT STOP AND HORN

**STEP 4.1**  
**FULLY TIGHTEN**  
**FAS0841, FAS0552,**  
**FAS0248**  
**3/16 ALLEN**  
**1/2 WRENCH**

**STEP 4.2**  
**FULLY TIGHTEN**  
**FAS0597, (2)**  
**FAS0552,**  
**AND FAS0248**  
**(2 PLACES)**  
**1/2 WRENCH**  
**1/2 SOCKET**

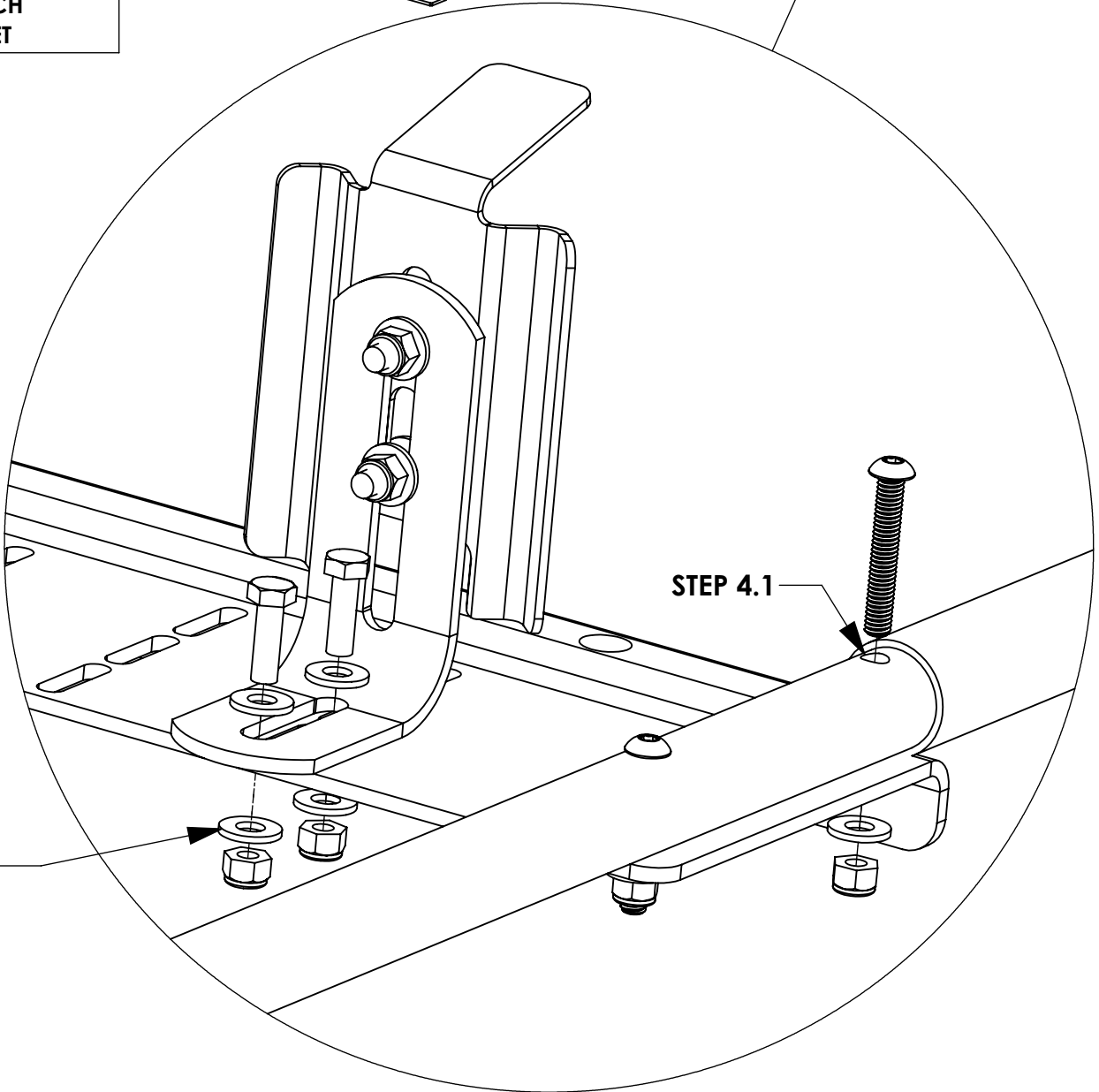
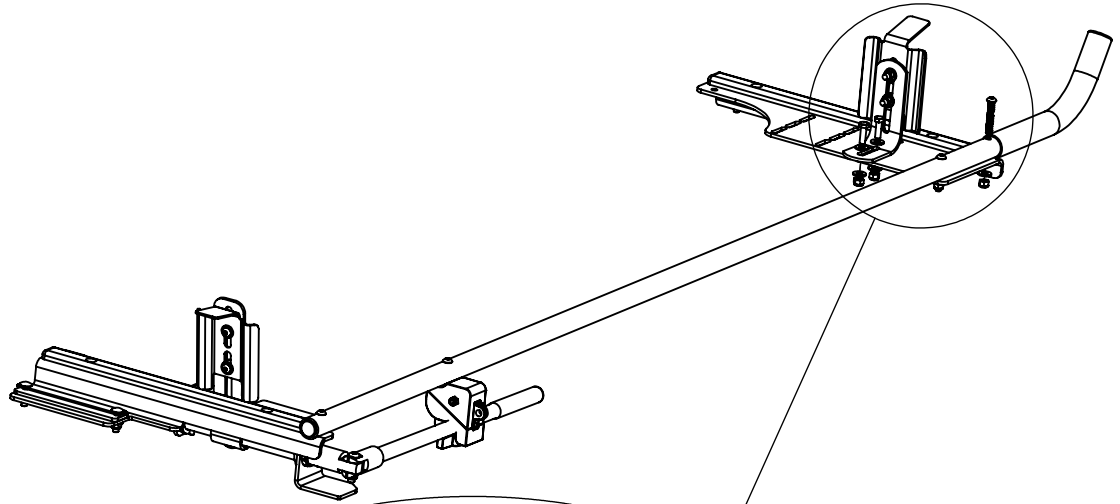

STEP 4.1

STEP 4.2

**STEP 4 - INSTALL GRIP LOCK INTO CROSSBOW**

**IF SHIP THRU FINAL DEALER SKIP THIS STEP. RACK IS ALREADY ON VEHICLE**

**STEP 5.1** **B.2**  
**SLIDE GRIP LOCK**  
**INTO CROSSBOW**

**LEAVE FASTENERS**  
**LOOSE FOR**  
**ADJUSTING RACK**  
**ONCE ON VEHICLE**

**STEP 5.2**  
**INSTALL MOUNTING**  
**FEET ONTO**  
**CROSSBOW**  
**(REFERENCE**  
**MOUNTING KIT**  
**INSTRUCTIONS)**

**STEP 5.3**  
**SLIDE GRIP LOCK**  
**OUT SO IT IS**  
**TOUCHING**  
**MOUNTING FEET AND**  
**FULLY TIGHTEN**  
**FASTENERS**

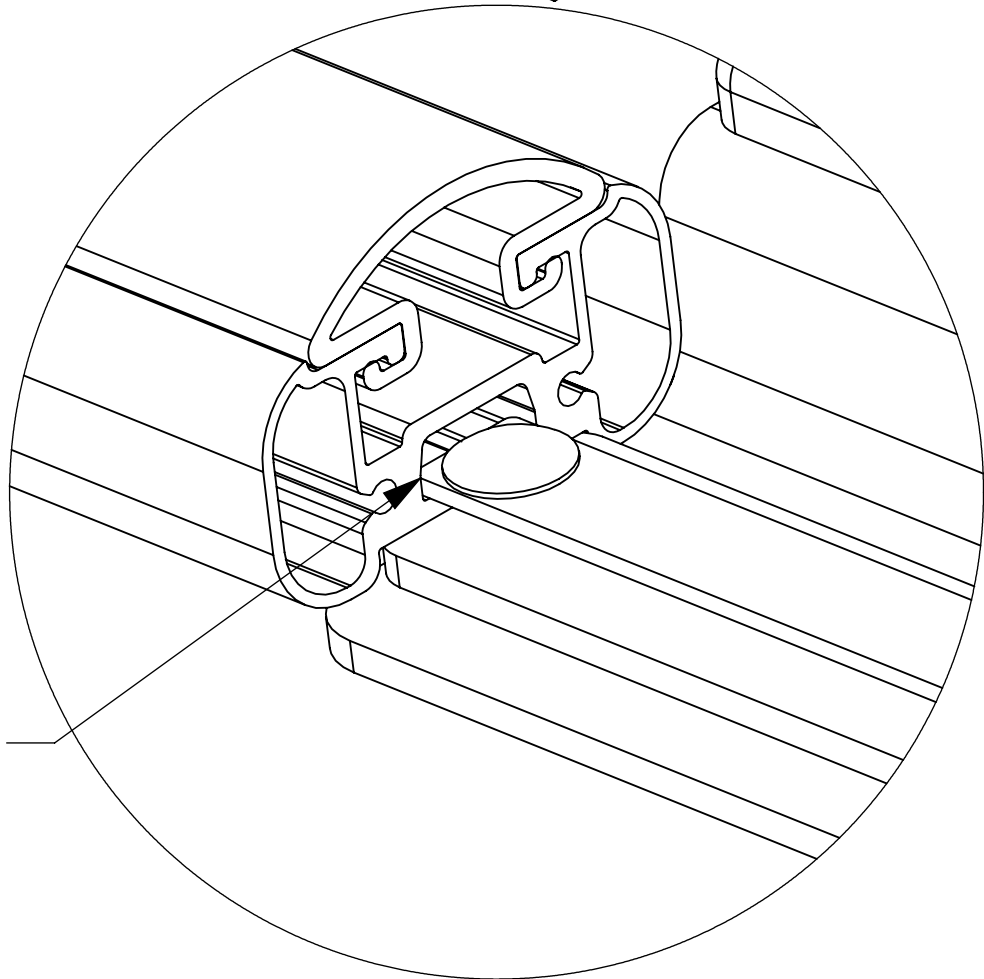
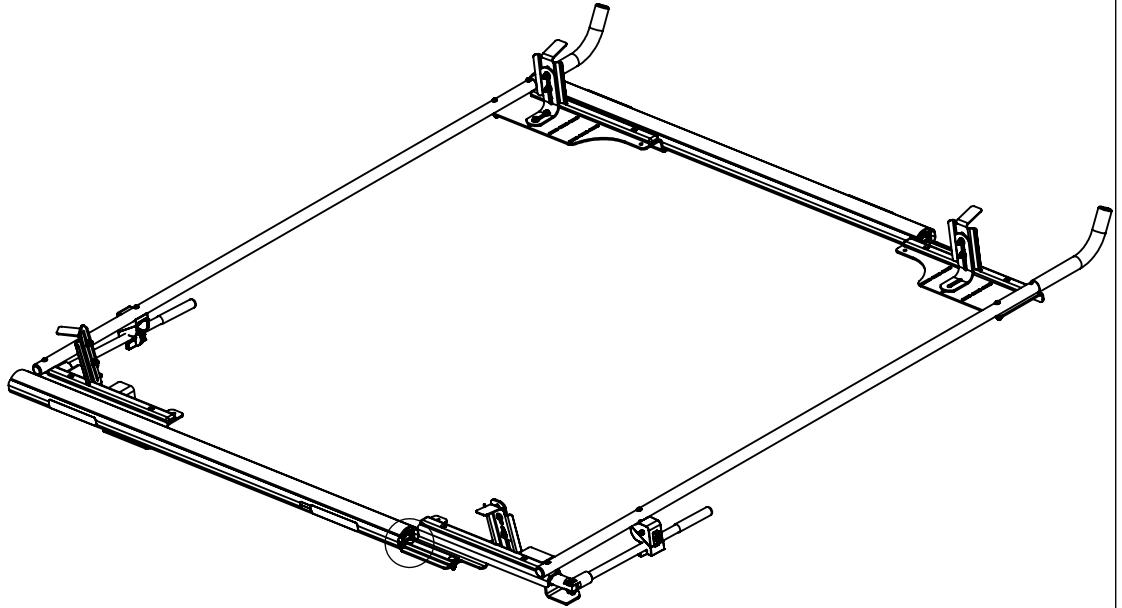

Step 5.1

**GRIP LOCK INSTALLATION IS COMPLETE!!!**



## Driver Side Grip-Lock Kit, Full Size Van



PRODUCT WEIGHT  
**37.7 LBS**

WIDTH x DEPTH x HEIGHT

**22" x 88" x 11"**

CAPACITY

**N/A**

COLOR

**WHITE/BLACK**

CATALOG NUMBER

**GL-FSVDS**

### PRODUCT FEATURES

Driver side kit PROFILE™ Grip-Lock and combo ladder racks. Works with all conduit kits.

Works on GM Express/Savana, Ford Transit Low Roof, and Nissan NV Low Roof vans. Not recommended for Medium Roof, High Roof, Ram Promaster Low Roof, or Mercedes Sprinter Low Roof vans.

Please refer to OEM specific mounting kit or rail kit for additional information on compatible accessories.

**SEE PAGE 2 FOR APPLICATION NOTES AND ACCESSORIES, OTHER PRODUCTS THAT WORK WITH THIS UNIT.**

**PAGE 1 of 2**

The information contained in this document is the sole property of ADRIAN STEEL COMPANY. ADRIAN STEEL COMPANY retains the right to modify and/or change the product of its design at any time without prior notification.



**CATALOG NUMBER      GL-FSVDS**

**PRODUCT APPLICATION**

**Driver side kit PROFILE™ Grip-Lock and combo ladder racks. Works with all conduit kits. Works on GM Express/Savana, Ford Transit Low Roof, and Nissan NV Low Roof vans. Not recommended for Medium Roof, High Roof, Ram Promaster Low Roof, or Mercedes Sprinter Low Roof vans.**

**ACCESSORIES THAT WILL WORK WITH THIS PRODUCT**

<b>CATALOG NUMBER</b>	<b>DESCRIPTION</b>
<b>2BARW</b>	<b>2-Crossbar Kit, 68”, White, Full Size Van</b>
<b>2BARCW</b>	<b>2-Crossbar Kit, 58”, White, Minivan</b>
<b>1BARW</b>	<b>Single Crossbar Kit, 68”, White, Full Size Van</b>
<b>1BARCW</b>	<b>Single Crossbar Kit, 58”, White, Minivan</b>

INSTR. NUMBER : 70691	PG: 1	REV: B	ITEM NO.	PART NUMBER	DESCRIPTION	GL-FSVDS	GL-FSVPS
PART NUMBER • <b>GL-FSVDS</b> PART NUMBER • <b>GL-FSVPS</b>			1	69445	GRIP LOCK FSV, ASM DS	1	-
			2	69444	GRIP LOCK FSV, ASM PS	-	1
PART • <b>GL FULL SIZE VEHICLE DS</b> DESC. • <b>GL FULL SIZE VEHICLE PS</b>			3	66373	GRIP LOCK BRKTS & HORN	1	1

**NOTE: THIS INSTRUCTION IS VALID FOR THE FOLLOWING KITS:**

- GL-FSVDS
- GL-FSVPS
- GL-FSVPSB
- GL-FSVDSB

**NOTE: 66357, 69444, & 69445 ARE AVAILABLE IN BLACK VARIANTS - FOR THEIR IDENTIFICATION, ADD THE "-B" SUFFIX TO THE END OF THE PART NUMBER**

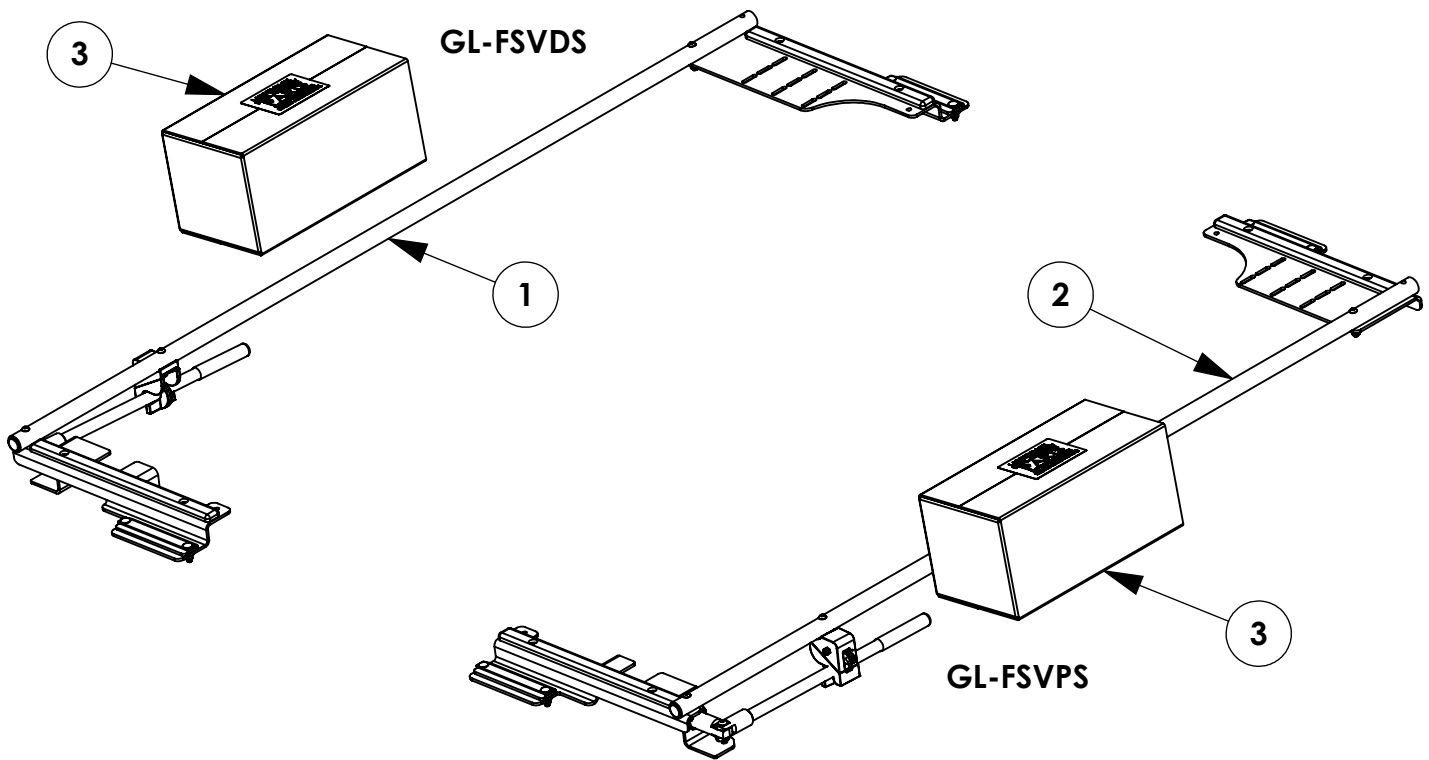

**\*\*IF BUILDING A DUAL SIDED RACK BUILD BOTH SIDES IN PARALLEL FOR EACH STEP. IF BUILDING SINGLE SIDED REFERENCE ONLY THAT SIDE WHEN BUILDING.\*\***

**TOOLS NEEDED:**  
 1/2" SOCKET  
 1/2" WRENCH  
 9/16" SOCKET  
 3/16" ALLEN WRENCH  
 DRIVE RATCHET  
 IMPACT DRIVER

**GET TO KNOW THE VEHICLE** - AT THE BEGINNING OF ANY INSTALLATION, CHECK THE LOCATION OF THE FUEL TANK, FUEL LINES, BRAKE LINES, HIGH VOLTAGE BATTERIES AND WIRING HARNESES TO AVOID INJURY OR PROPERTY DAMAGE FROM TOOL CONTACT.

**SEAL ALL EXTERIOR HOLES** - ALL INSTALLATION HOLES SHOULD BE SEALED WITH BUTYL TAPE OR SILICON TO PREVENT WATER AND EXHAUST GASES FROM ENTERING THE VEHICLE.

**CONTROL DRILL DEPTH** - TO AVOID DAMAGE TO THE VEHICLE, USE A DRILL STOP OR CLEARED STEP BIT WHEN DRILLING INSTALLATION HOLES.

**ALWAYS ADD PRIMER** - WHEN ADDING INSTALLATION HOLES BE SURE TO USE A SELF-ETCHING PRIMER TO PREVENT CORROSION, FASTENER FAILURE AND INJURY.

**MOUNTING POINTS MUST HAVE METAL-TO-METAL CONTACT** - USE PROVIDED MOUNTING SPACERS TO ACCOMMODATE FOR VEHICLE FEATURES, CARPET OR SUBFLOORS.

**PROVIDE CLEARANCE FOR SPACERS** - IF THE INSTALLATION VEHICLE CONTAINS A CARPET OR SUBFLOOR, USE A 1-3/16" DIAMETER CARPET CUTTER (P/N: 31183-0) AT ALL MOUNTING LOCATIONS TO OPEN UP ROOM FOR SPACERS.

**CHECK SPACER ORIENTATION** - BE SURE THAT THE INDENT IN THE SPACER COVERS THE PLUSNUT HEAD; THIS ENSURES THE MOST METAL-TO-METAL CONTACT AND REDUCES VIBRATION.

**PLUSNUT INSTALLATION** - A PLUSNUT GUN IS RECOMMENDED FOR PLUSNUT INSTALLATION FOR ITS PRODUCTION SPEED. HOWEVER, A PLUSNUT SETTING TOOL CAN ALSO BE USED (P/N: 22200-0).

**THRU-BOLT CLEARANCE** - WHEN USING A THRU-BOLT AT ANY MOUNTING LOCATION, BE SURE THAT YOUR HOLE HAS 1/16" CLEARANCE.

PAGE:

**3**

***FASTENERS USED  
BAG REFERENCE:***

**NO FASTENER BAG  
ALL FASTENERS INCLUDED IN ASSEMBLY**

# STEP 1 - INSTALL GRIP LOCK FOR SHIP THRU

**STEP 1.1**  
SLIDE GRIP LOCK  
INTO CROSSBOW

**STEP 1.2**  
SLIDE RACKS ALL  
THE WAY TO CENTER  
OF CROSSBOW AND  
FULLY TIGHTEN FOR  
SHIP THRU  
TRANSPORTATION  
1/2" SOCKET

**STEP 1.3**  
FULLY TIGHTEN  
END CAPS  
FAS0473, 63851  
(02 PLACES PER END  
CAP)  
5/16" SOCKET

**STEP 1.4**  
STORE PARTS BOX  
66373 IN VEHICLE  
FOR FINAL INSTALL  
(1 BOX FOR SINGLE,  
2 BOXES FOR  
DOUBLE)

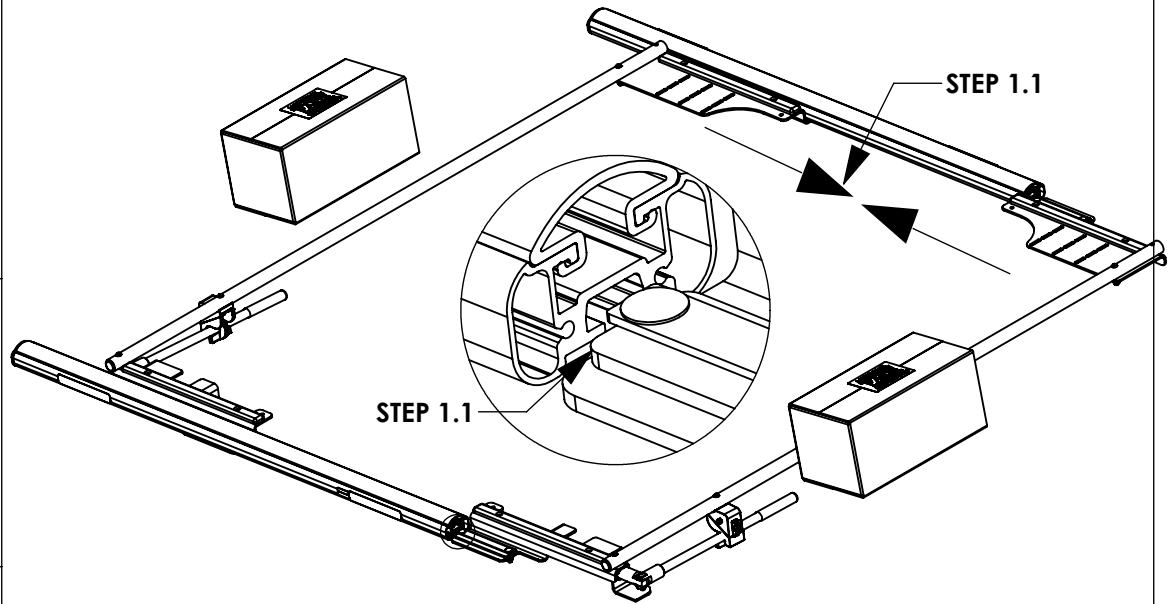

**STEP 1.4**  
STORE PARTS BOX  
66373 IN VEHICLE

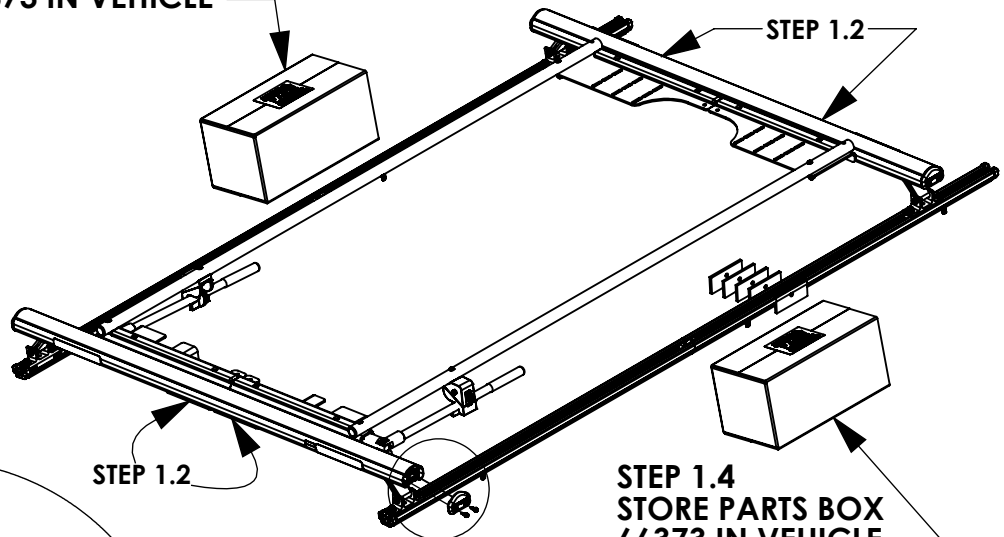

**STEP 1.4**  
STORE PARTS BOX  
66373 IN VEHICLE

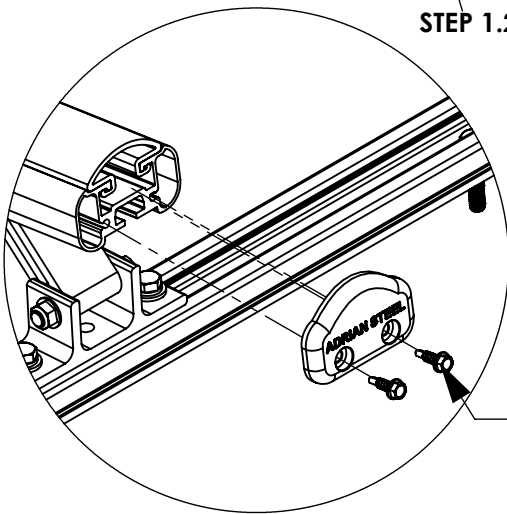

**STEP 1.3**

**CHECK THAT ALL FASTENERS ARE TIGHTENED!!! INSTALLATION IS COMPLETE**

INSTR. NUMBER : **69484**

PG: **1** REV: **A**

PART NUMBER • **Standard Drop ProLift**  
• **Low & Compact Vans**

PART DESC. • ProLift Adjustment Instructions -  
• **Standard Drop**  
• **Low Roof & Compact Vans**

**Step 3: With 1/2" Socket loosen nut, slide post so that it is snug against the ladder. Tighten nut**

**Step 1: With 1/2" Socket loosen nut, slide post so that it is snug against the ladder. Tighten nut**

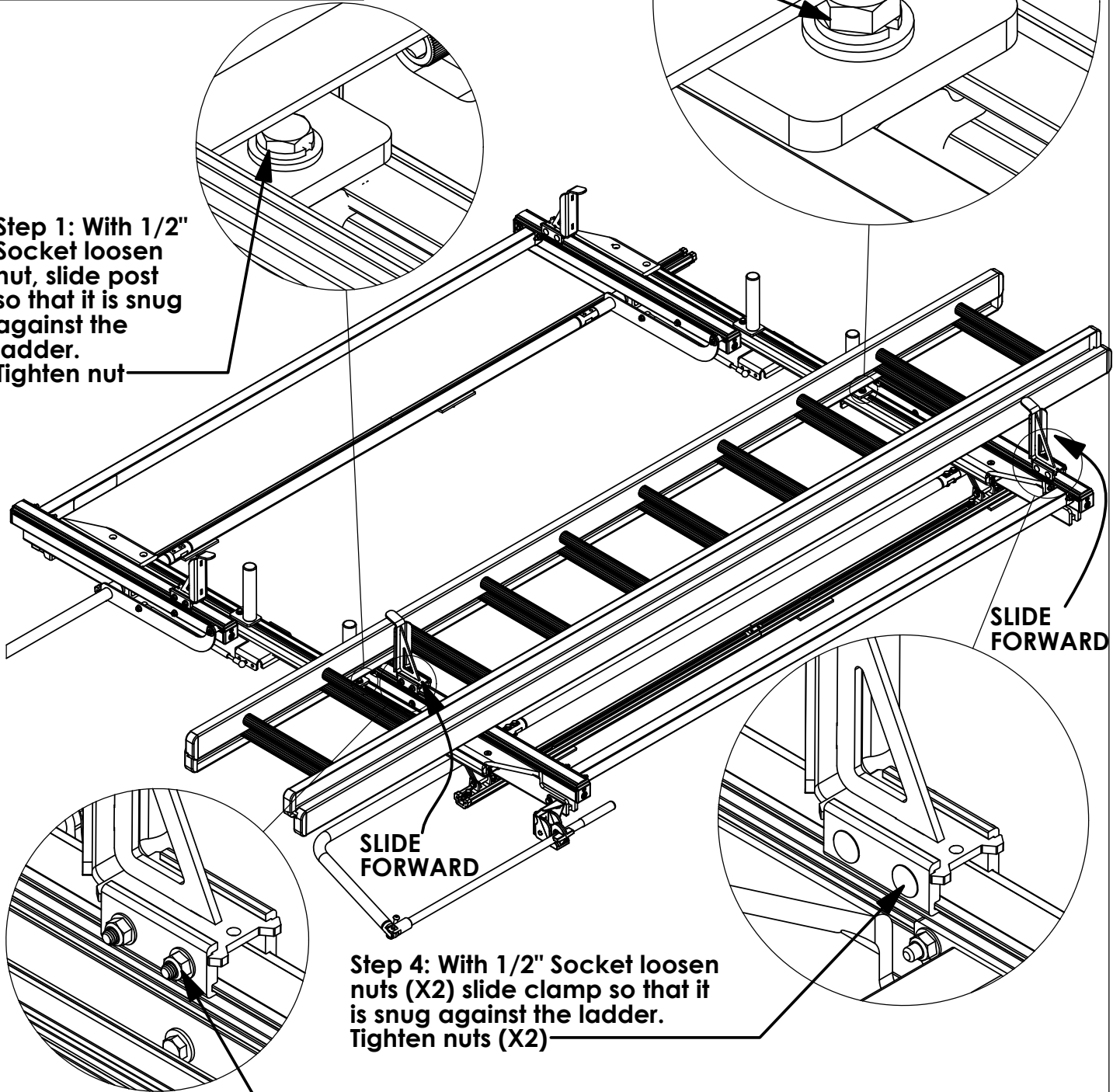

**SLIDE FORWARD**

**SLIDE FORWARD**

**Step 4: With 1/2" Socket loosen nuts (X2) slide clamp so that it is snug against the ladder. Tighten nuts (X2)**

**Step 2: With 1/2" Socket loosen nuts (X2) slide clamp so that it is snug against the ladder. Tighten nuts (X2)**

**Once all brackets are adjusted operate rack to make sure clamps are not too tight**

INSTR. NUMBER	PG:	REV:	ITEM NO.	PART NUMBER	DESCRIPTION	QTY.
: <b>68497</b>	<b>1</b>	<b>C</b>	1	68298-W	STD DROP CARTRIDGE, LR DS, WHITE	1
			2	68013-W	DROP DOWN FRONT ARM ASM DS, WHITE	1
			3	66563-B	DROP DOWN, SS CENTER DRIVELINE, BLK	1
PART NUMBER : <b>PLSDPSL &amp; PLSDDSL</b>			4	66959-W	DROP DOWN OUTER BAR, WELDMENT, WHITE	1
			5	66611-B	DROP DOWN, PIVOT HANDLE, BLK	1
PART • PROLIFT,STD,PS,LR DESC. • & PROLIFT,STD,DS,LR			6	58239	COMPRESSION DAMPER	1
			7	48265	DAMPER ASSEMBLY	1
<b>PLSDDSLW</b>			8	68186-W	PROLIFT INNER POST, WHITE	2
			9	68180-W	DROP DOWN LATCH BRACKET, WHITE	1
			10	25340-0	HANDLE LATCH-STD	1
			11	68037-B	CLAMP PAD, 6.5", BLACK	2
			12	68045-W	PROLIFT DAMPER MOUNT, WHITE	2

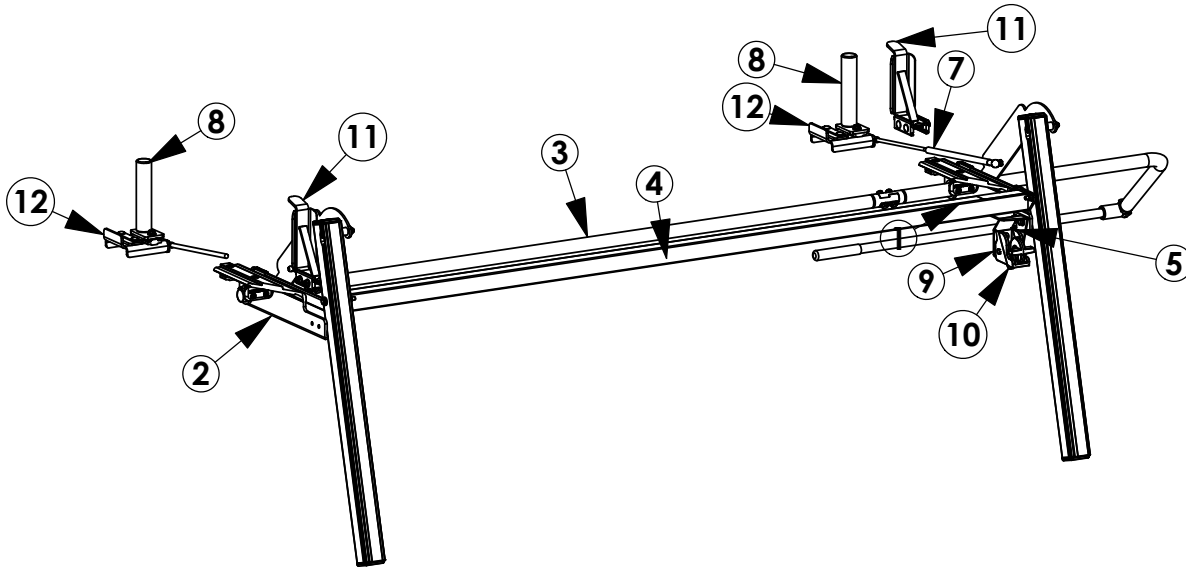

ITEM NO.	PART NUMBER	DESCRIPTION	QTY.
1	68297-W	STD DROP CARTRIDGE, LR PS, WHITE	1
2	68031-W	DROP DOWN FRONT ARM ASSM PS, WHITE	1
3	66572-B	DROP DOWN, CS CENTER DRIVELINE, BLK	1
4	66959-W	DROP DOWN OUTER BAR, WELDMENT, WHITE	1
5	66611-B	DROP DOWN, PIVOT HANDLE, BLK	1
6	58239	COMPRESSION DAMPER	1
7	48265	DAMPER ASSEMBLY	1
8	68045-W	PROLIFT DAMPER MOUNT, WHITE	2
9	68186-W	PROLIFT INNER POST, WHITE	2
10	68180-W	DROP DOWN LATCH BRACKET, WHITE	1
11	25340-0	HANDLE LATCH-STD	1
12	68037-B	CLAMP PAD, 6.5", BLACK	2

**PLSDPSLW**

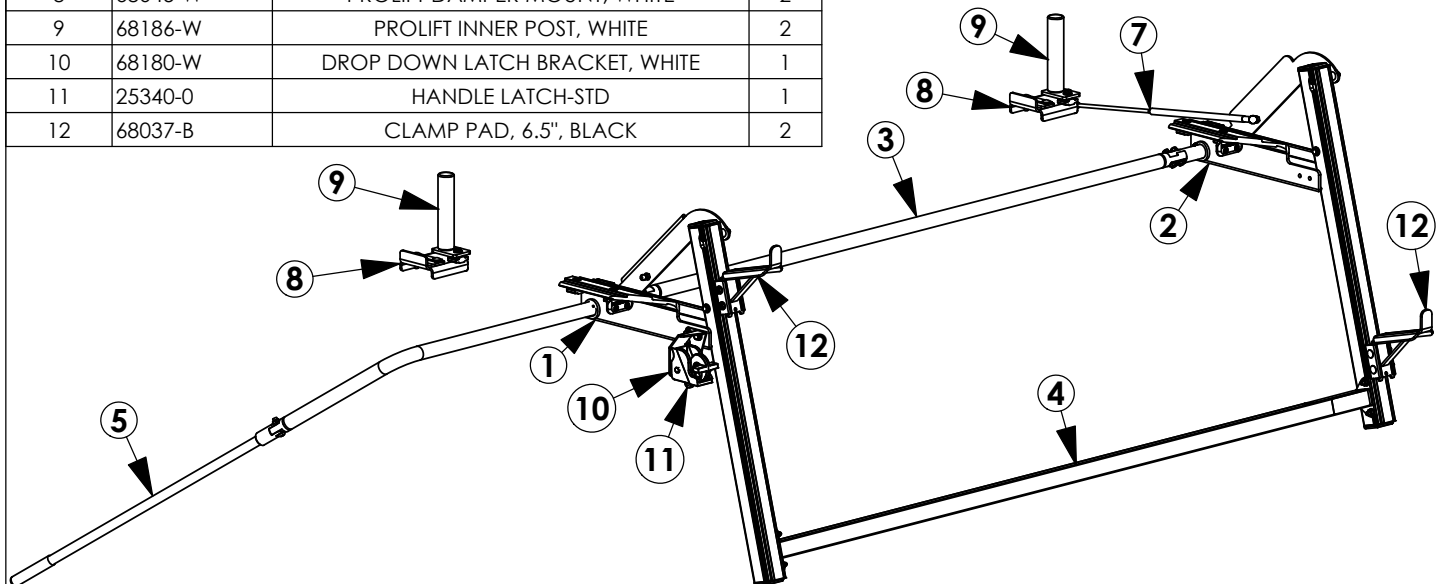

**GET TO KNOW THE VEHICLE** - AT THE BEGINNING OF ANY INSTALLATION, CHECK THE LOCATION OF THE FUEL TANK, FUEL LINES, BRAKE LINES, HIGH VOLTAGE BATTERIES AND WIRING HARNESES TO AVOID INJURY OR PROPERTY DAMAGE FROM TOOL CONTACT.

**SEAL ALL EXTERIOR HOLES** - ALL INSTALLATION HOLES SHOULD BE SEALED WITH BUTYL TAPE OR SILICON TO PREVENT WATER AND EXHAUST GASES FROM ENTERING THE VEHICLE.

**CONTROL DRILL DEPTH** - TO AVOID DAMAGE TO THE VEHICLE, USE A DRILL STOP OR CLEARED STEP BIT WHEN DRILLING INSTALLATION HOLES.

**ALWAYS ADD PRIMER** - WHEN ADDING INSTALLATION HOLES BE SURE TO USE A SELF-ETCHING PRIMER TO PREVENT CORROSION, FASTENER FAILURE AND INJURY.

**MOUNTING POINTS MUST HAVE METAL-TO-METAL CONTACT** - USE PROVIDED MOUNTING SPACERS TO ACCOMMODATE FOR VEHICLE FEATURES, CARPET OR SUBFLOORS.

**PROVIDE CLEARANCE FOR SPACERS** - IF THE INSTALLATION VEHICLE CONTAINS A CARPET OR SUBFLOOR, USE A 1-3/16" DIAMETER CARPET CUTTER (P/N: 31183-0) AT ALL MOUNTING LOCATIONS TO OPEN UP ROOM FOR SPACERS.

**CHECK SPACER ORIENTATION** - BE SURE THAT THE INDENT IN THE SPACER COVERS THE PLUSNUT HEAD; THIS ENSURES THE MOST METAL-TO-METAL CONTACT AND REDUCES VIBRATION.

**PLUSNUT INSTALLATION** - A PLUSNUT GUN IS RECOMMENDED FOR PLUSNUT INSTALLATION FOR ITS PRODUCTION SPEED. HOWEVER, A PLUSNUT SETTING TOOL CAN ALSO BE USED (P/N: 22200-0).

**THRU-BOLT CLEARANCE** - WHEN USING A THRU-BOLT AT ANY MOUNTING LOCATION, BE SURE THAT YOUR HOLE HAS 1/16" CLEARANCE.

## FASTENERS AND HARDWARE USED

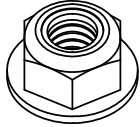

FAS0861  
NUT,HEX NLK FLG 5/16-18  
QTY: 18



FAS0110  
NUT,HEX NLK 3/8-16  
QTY: 01

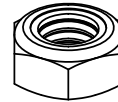

FAS0399  
NUT,HEX NLK LT 3/8-16  
QTY: 01

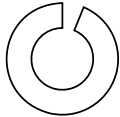

FAS0588  
WASHER,LCK SPLIT 5/16  
QTY: 03

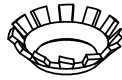

FAS0857  
WASHER,LCK EXT CS 5/16  
QTY: 04

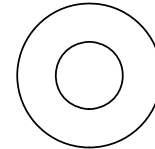

FAS0552  
WASHER,FLAT USS 5/16  
QTY: 09

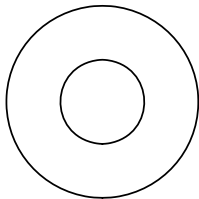

FAS0720  
WASHER,FLAT USS 3/8  
QTY: 01

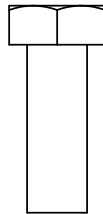

FAS0283  
SCREW,HH 5/16-18X.875  
QTY: 02

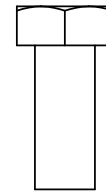

FAS0799  
SCREW,HH 5/16-18X.75  
QTY: 02

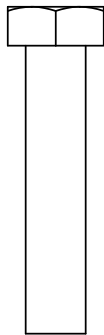

FAS0242  
SCREW,HH 5/16-18X1.5  
QTY: 04

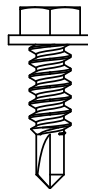

FAS0473  
SCREW,HH TEK #12X.75  
QTY: 04

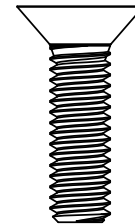

FAS0856  
SCREW,FHH 5/16-18X1.13  
QTY: 04

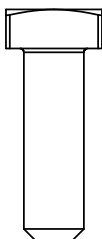

FAS0035  
BOLT,SQ HD 5/16-18X1.0  
QTY: 08

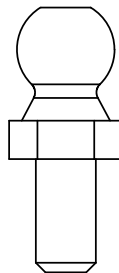

34927-0  
BALL STUD 13MM X 5/16-18  
QTY: 02

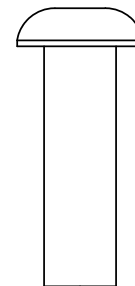

FAS0701  
SCREW,BHCS 3/8-16X1.25  
QTY: 01

**FASTENERS AND HARDWARE USED**

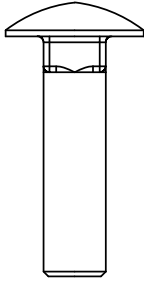

FAS0812  
BOLT,CRG 5/16-18X1.25  
QTY: 04

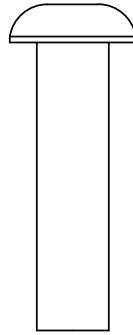

FAS0819  
SCREW,BHCS 3/8-16X1.5  
QTY: 01

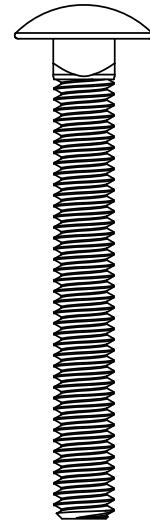

FAS0838  
BOLT,CRG 5/16-18X2.5  
QTY: 04

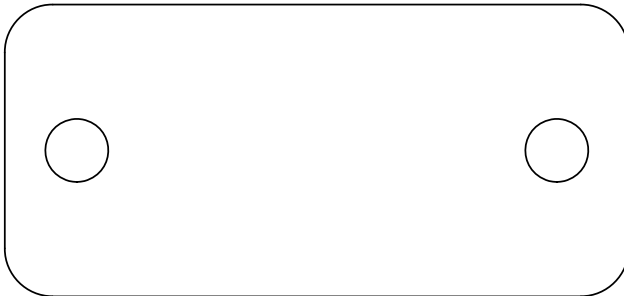

64831  
REAR ROLLER, SPACER  
QTY: 02

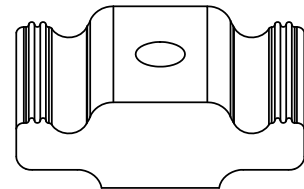

63490  
RAIL SLIDE, 1"  
QTY: 06

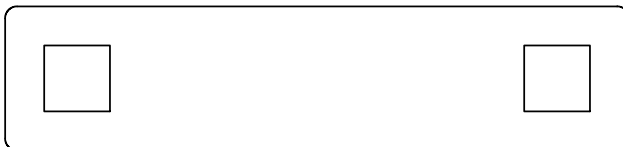

64830  
REAR ROLLER, BOLT PLATE  
QTY: 02

**DISCARD**

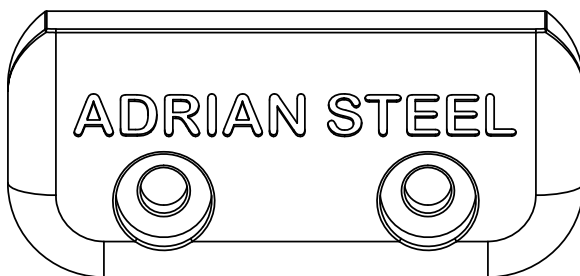

65961  
DROP DOWN END CAP  
QTY: 02

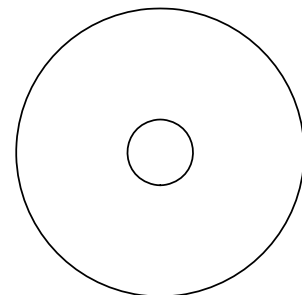

FAS0603  
SCREW,HH 5/16-18X.875  
QTY: 02

**BEGIN ASSEMBLY**

**STEP 1 - INSTALL CLAMPS AND HARDWARE ON DROP DOWN CARTRIDGES**

**PASSENGER SIDE  
CARTRIDGES**

**REAR SUB-  
ASSEMBLY**

**FRONT SUB-  
ASSEMBLY**

**MUST BE THIS ORIENTATION!**

LEAVE LOOSE

USE FAS0856,  
FAS0857, & 63490  
(02 PLACES)  
3/16" ALLEN

LEAVE LOOSE

USE FAS0856,  
FAS0857, & 63490  
(02 PLACES)  
3/16" ALLEN

USE FAS0838 & FAS0861  
(02 PLACES)  
1/2" SOCKET

FAS0035  
SLIDE INTO SLOT  
(02 PLACES)

USE FAS0838 & FAS0861  
(02 PLACES)  
1/2" SOCKET

FAS0035  
SLIDE INTO SLOT  
(02 PLACES)

USE FAS0799,  
FAS0552, & FAS0588  
(02 PLACES)  
1/2" SOCKET

USE FAS0701,  
FAS0720, & FAS0110  
(02 PLACES)  
7/32" ALLEN  
9/16" SOCKET

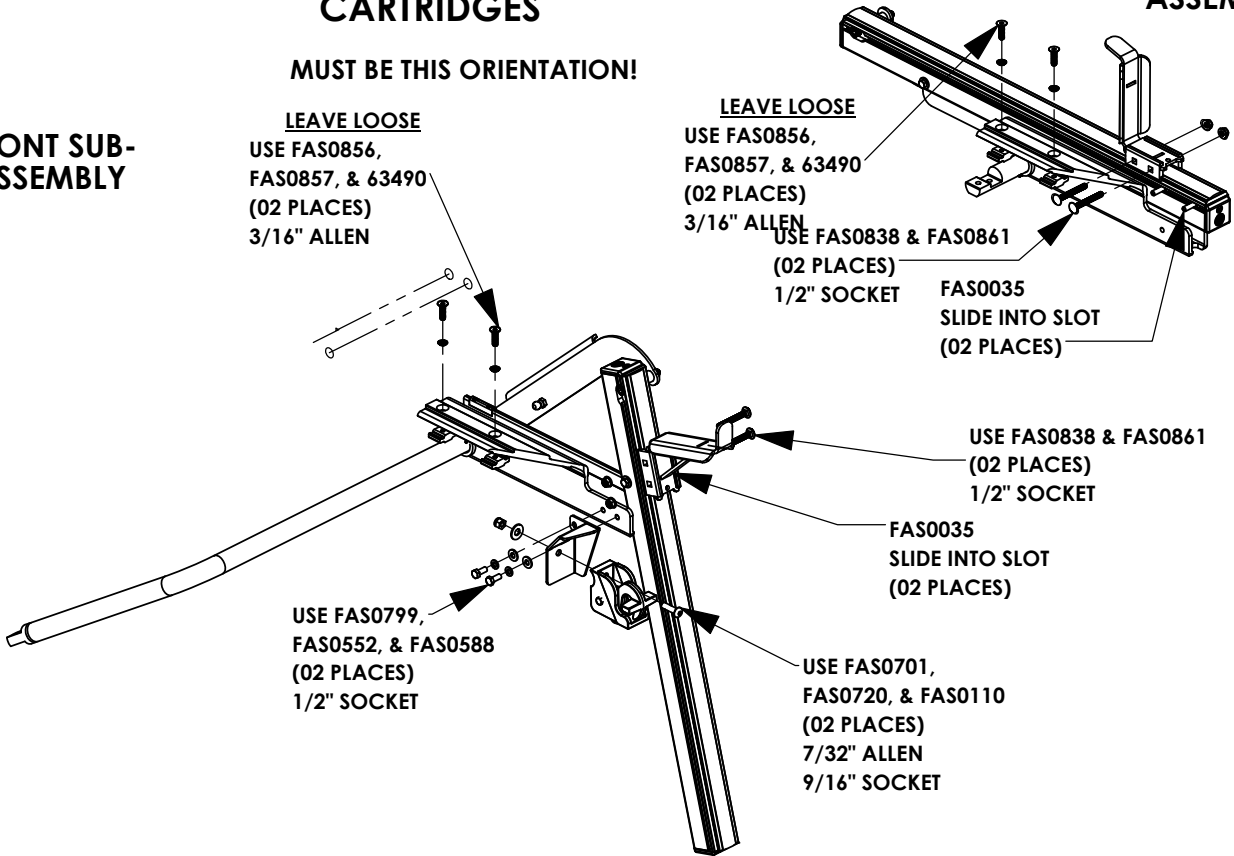

**DRIVER SIDE  
CARTRIDGES**

**REAR SUB-  
ASSEMBLY**

**MUST BE THIS ORIENTATION!**

USE FAS0838 & FAS0861  
(02 PLACES)  
1/2" SOCKET

LEAVE LOOSE

USE FAS0856,  
FAS0857, & 63490  
(02 PLACES)  
3/16" ALLEN

LEAVE LOOSE

USE FAS0856,  
FAS0857, & 63490  
(02 PLACES)  
3/16" ALLEN

USE FAS0838 & FAS0861  
(02 PLACES)  
1/2" SOCKET

FAS0035  
SLIDE INTO SLOT  
(02 PLACES)

**FRONT SUB-  
ASSEMBLY**

USE FAS0799,  
FAS0552, & FAS0588  
(02 PLACES)  
1/2" SOCKET

USE FAS0701,  
FAS0720, & FAS0110  
(02 PLACES)  
7/32" ALLEN  
9/16" SOCKET

FAS0035  
SLIDE INTO SLOT  
(02 PLACES)

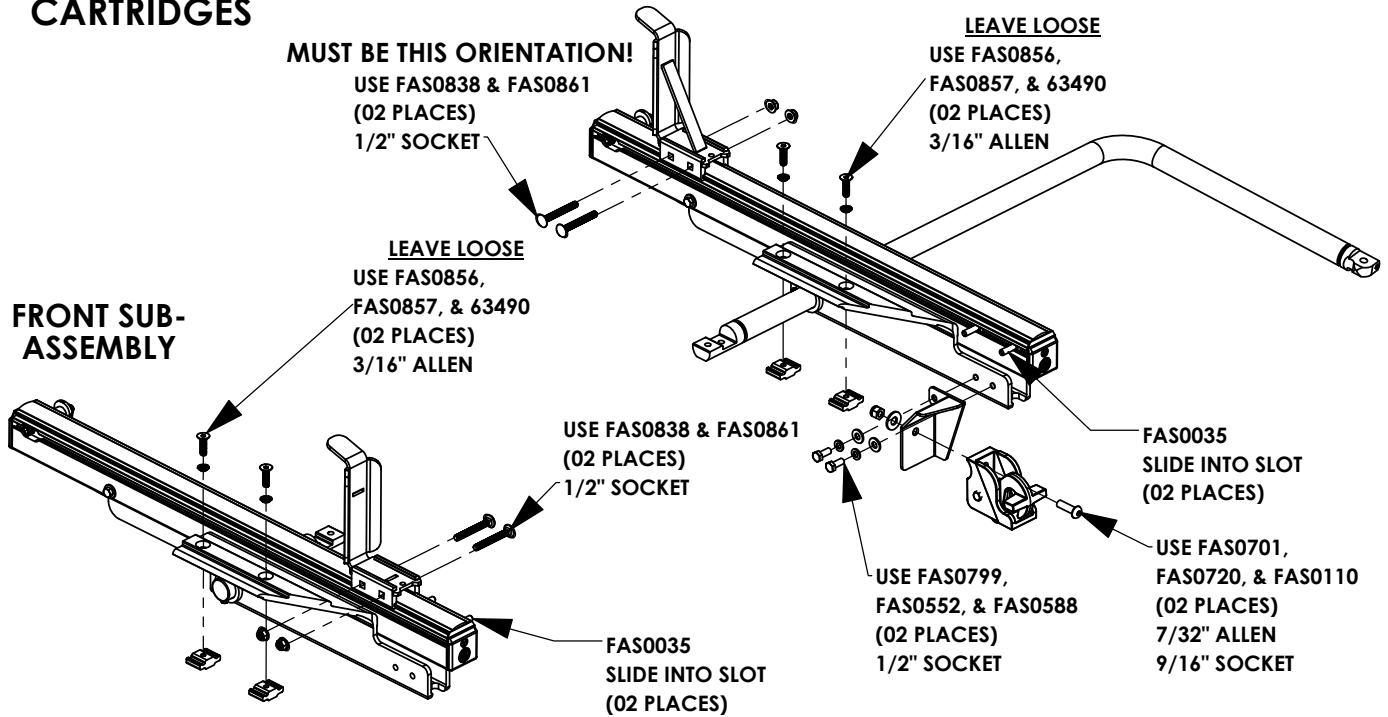

# STEP 2 - MOUNT DAMPER BRACKETS AND INNER STOPS TO CROSSBOWS

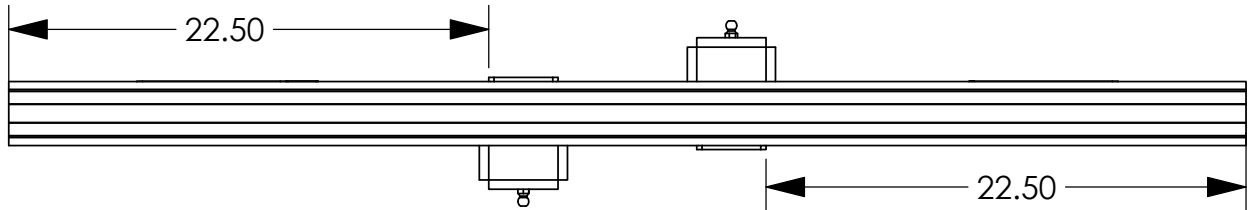
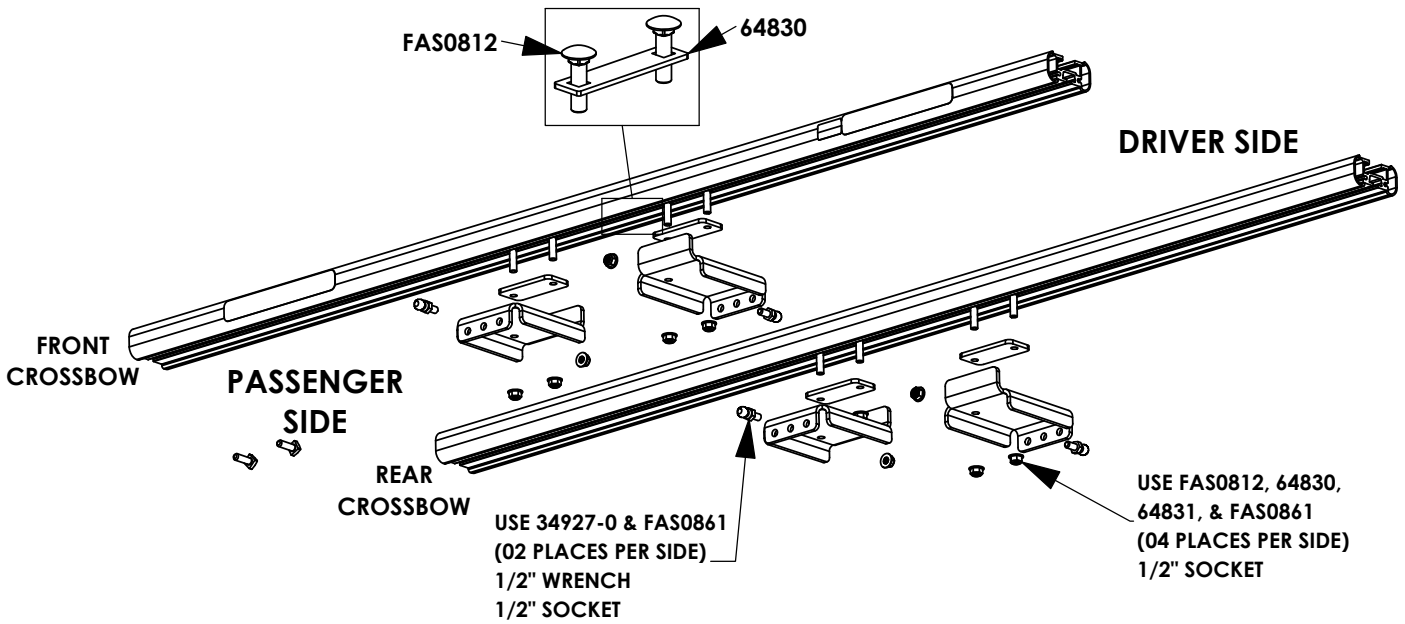

MOUNT 22" FROM THE  
END OF THE CROSSBOW

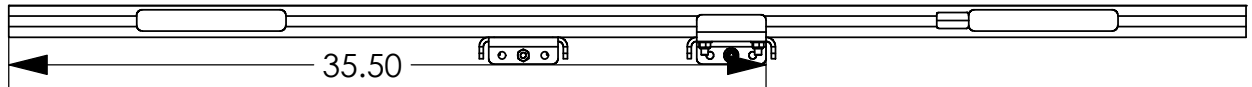

USE FAS0283,  
FAS0552, & 63490  
(02 PLACES PER SIDE)  
1/2" SOCKET

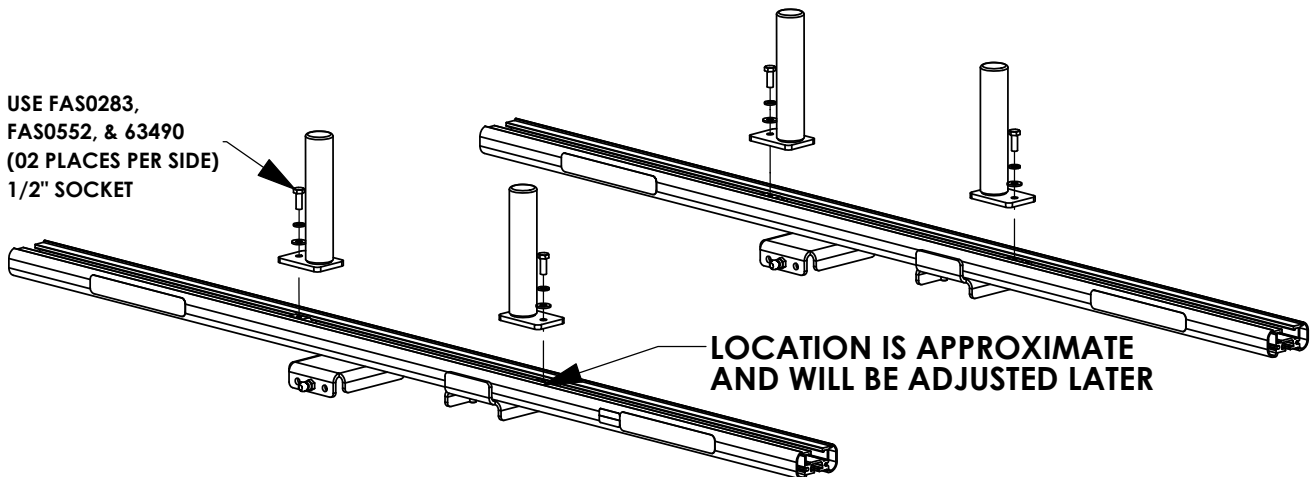

### STEP 3 - INSTALL CARTRIDGES ON CROSSBOWS

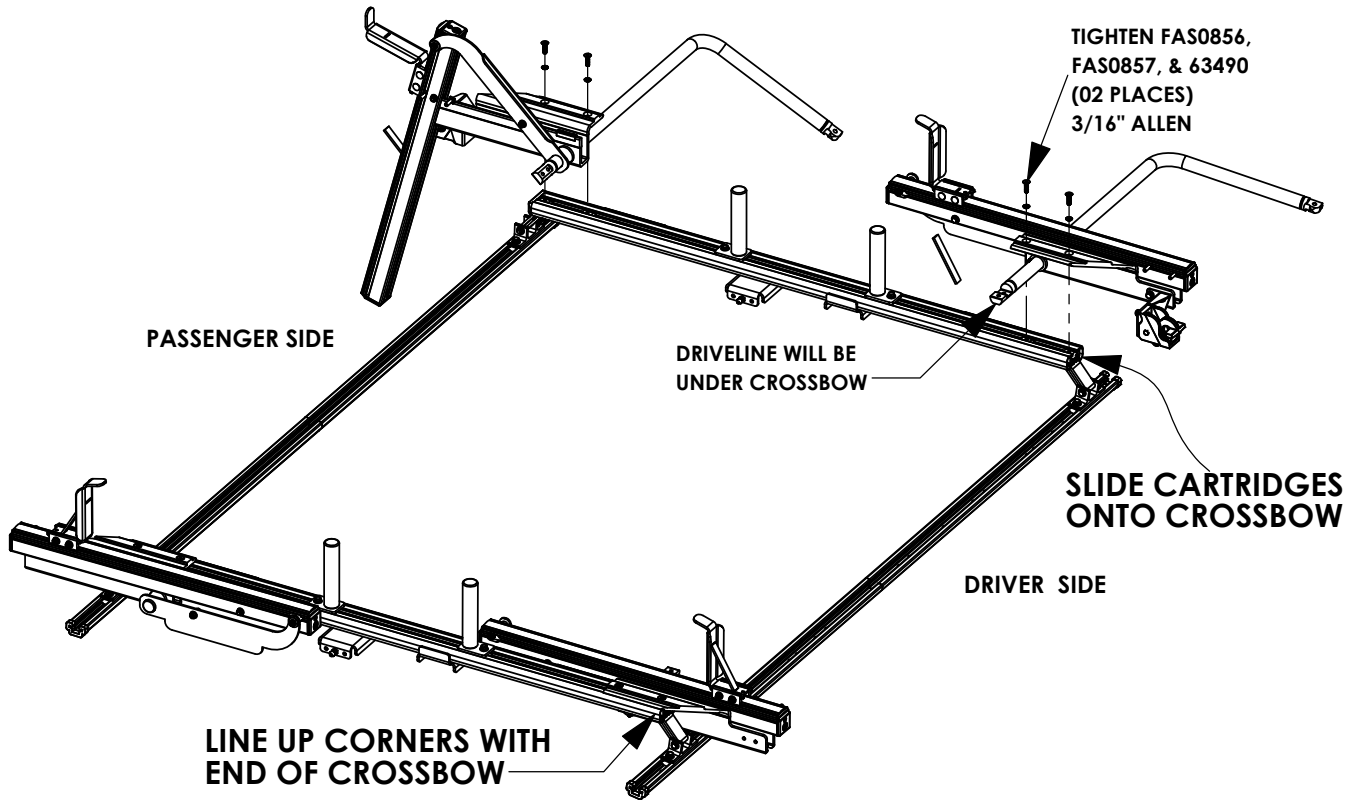

### STEP 4 - INSTALL CROSSBOW END CAPS

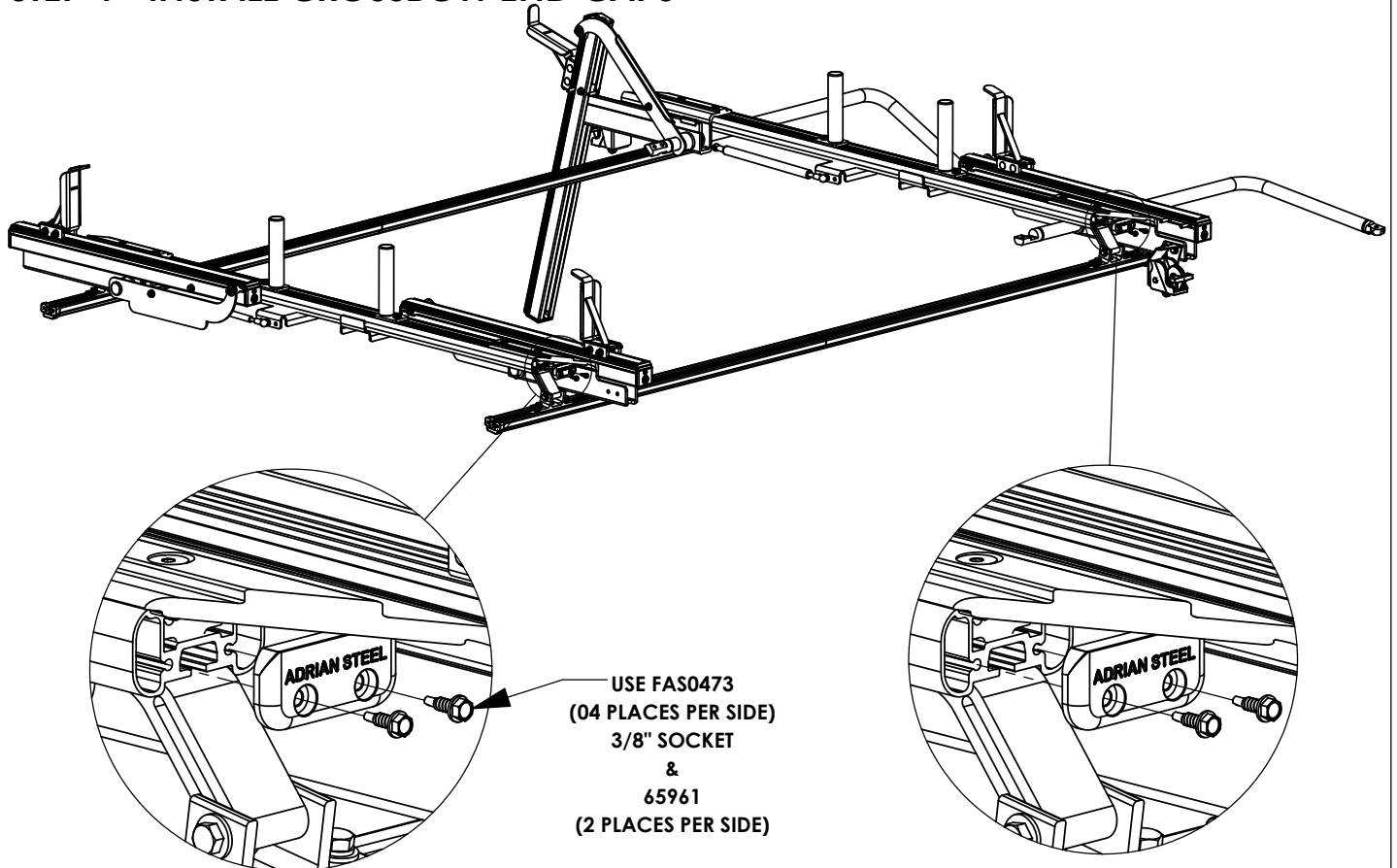

### STEP 5 - INSTALL DAMPERS AND DROP DOWN HANDLE

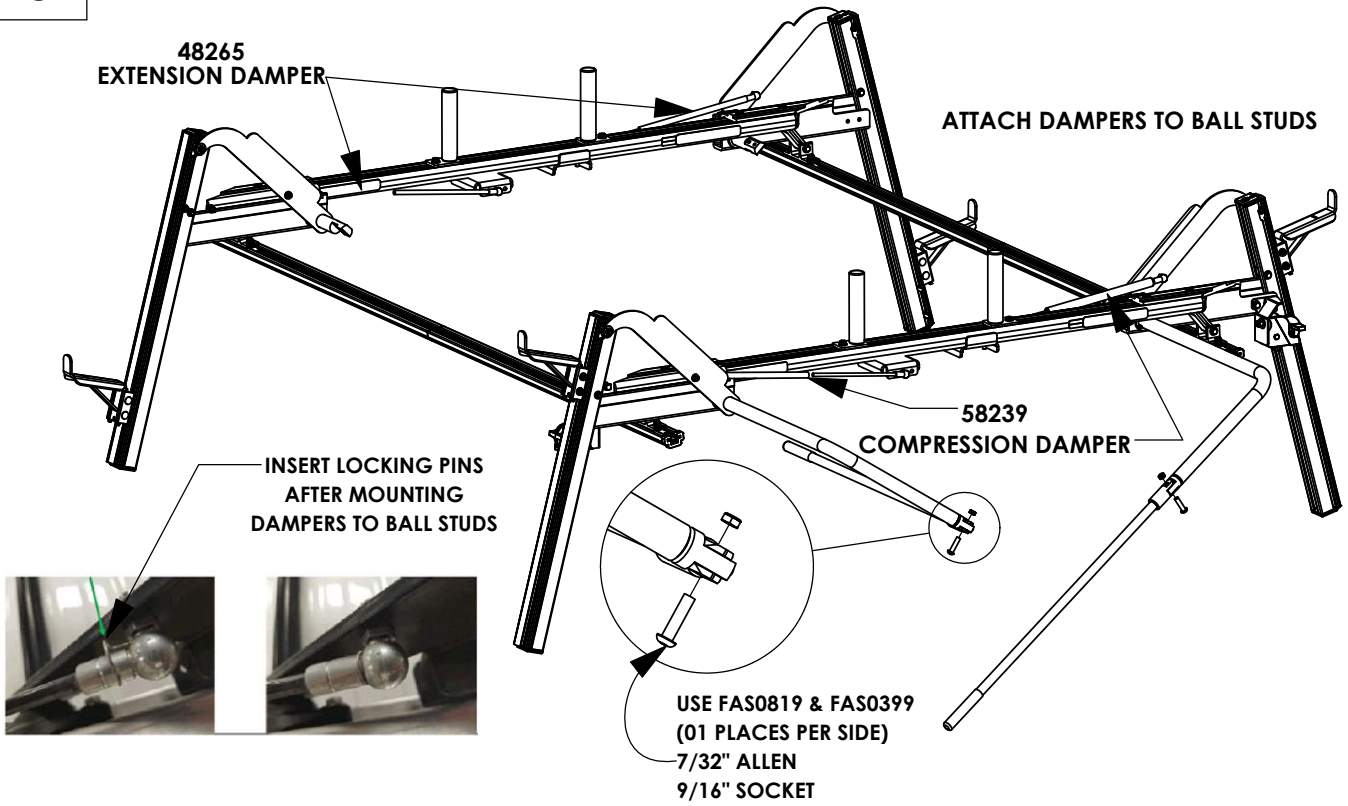

### STEP 6 - INSTALL DRIVELINE AND O.S. BAR

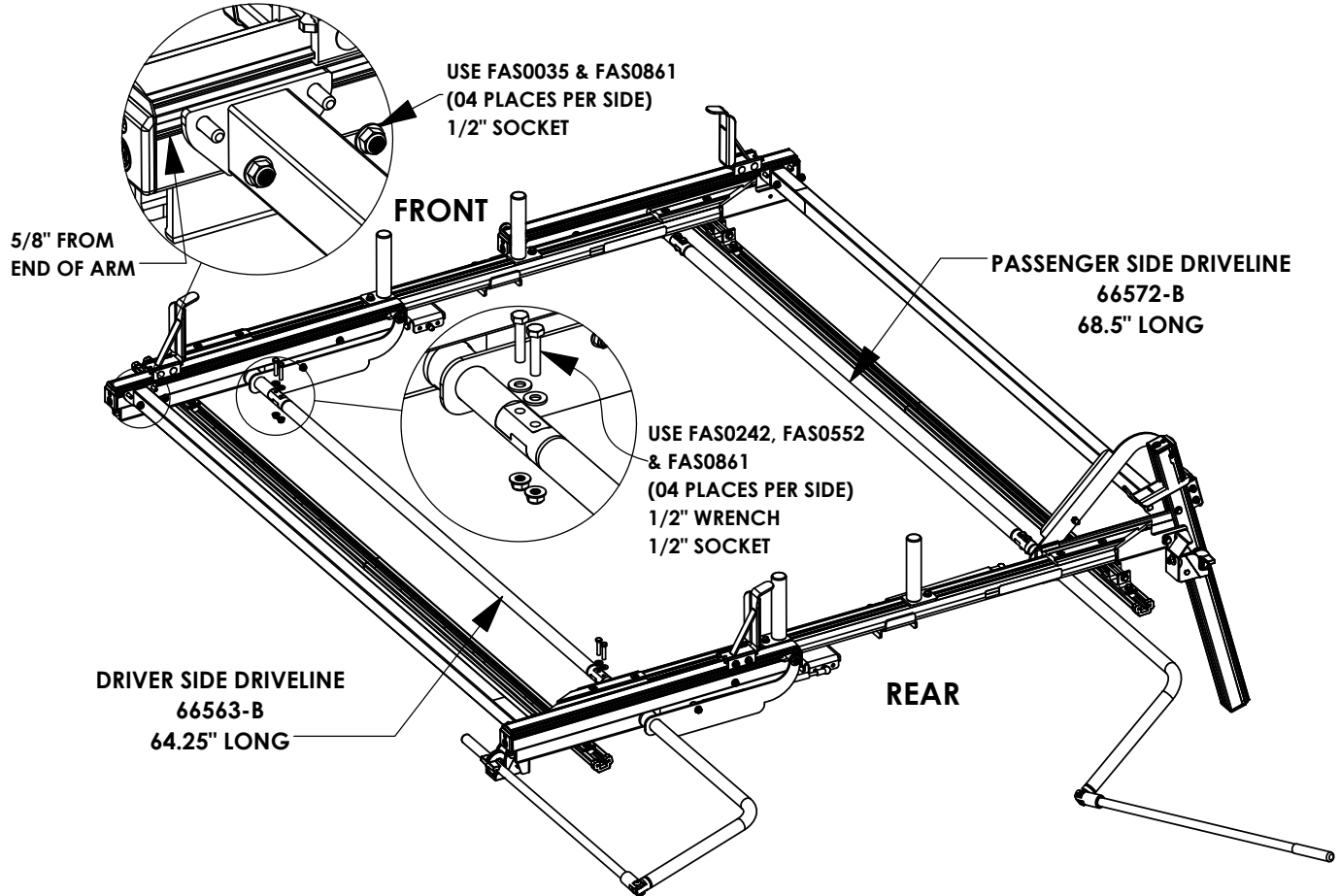



## Mounting Roof Rail Kit, Transit

PRODUCT WEIGHT  
**7.2 LBS**

HEIGHT OFF ROOF

**SEE TABLE BELOW**



CAPACITY  
**REFER TO OEM'S  
RECOMMENDED LOAD  
RATING**

COLOR

**RAW**

CATALOG NUMBER

**RRKFT**

### PRODUCT FEATURES

**Ford Transit aluminum mounting roof rail kit for the PROFILE™ HD Utility, Grip-Lock, ProLift, and combo ladder racks. Mounting kit works on all roof height and wheelbase combinations for Ford Transit vans.**

**Utility and Grip-Lock racks are not recommended for medium or high roof vehicles!**

**SEE PAGES 2 & 3 FOR APPLICATION NOTES AND ACCESSORIES, OTHER PRODUCTS THAT WORK WITH THIS UNIT.**

**PAGE 1 of 4**

The information contained in this document is the sole property of ADRIAN STEEL COMPANY. ADRIAN STEEL COMPANY retains the right to modify and/or change the product of its design at any time without prior notification.



**CATALOG NUMBER RRKFT**

**PRODUCT APPLICATION**

**This product is designed to be installed Ford Transit vans. HD Utility and Grip-Lock racks are not recommended for medium or high roof vehicles!**

**ACCESSORIES THAT WILL WORK WITH THIS PRODUCT**

CATALOG NUMBER	DESCRIPTION	CATALOG NUMBER	DESCRIPTION
<b>White Kit Part Numbers</b>		<b>Black Kit Part Numbers</b>	
<b>Crossbow Kits</b>			
2BARW	2-Crossbar Kit, 68", White, Full Size Van	2BARB	2-Crossbar Kit, 68", Black, Full Size Van
1BARW	2-Crossbar Kit, 48", White, Full Size Van	1BARB	2-Crossbar Kit, 48", Black, Full Size Van
2BARCW	2-Crossbar Kit, 48", White, Minivan	2BARCB	2-Crossbar Kit, 48", Black, Minivan
1BARCW	Single Crossbar Kit, 48", White, Minivan	1BARCB	Single Crossbar Kit, 48", Black, Minivan
<b>Mounting Bracket Kits</b>			
URMBK4W	Mounting Bracket Kit, 4-Pack, White, Multiple Vehicles	URMBK4B	Mounting Bracket Kit, 4-Pack, Black, Multiple Vehicles
URMBK2W	Mounting Bracket Kit, 2-Pack, White, Multiple Vehicles	URMBK2B	Mounting Bracket Kit, 2-Pack, Black, Multiple Vehicles
<b>Ladder Stop &amp; Upright Kits</b>			
ULSKB	Single Ladder Stop Kit, Black	ULSKAB	Single Ladder Stop Kit, Black
4UPK4B	4" Upright Kit, 4-Pack, Black	4UPK4AB	4" Upright Kit, 4-Pack, Black
4UPK2B	4" Upright Kit, 2-Pack, Black	4UPK2AB	4" Upright Kit, 2-Pack, Black
6UPK4B	6" Upright Kit, 4-Pack, Black	6UPK4AB	6" Upright Kit, 4-Pack, Black
6UPK2B	6" Upright Kit, 2-Pack, Black	6UPK2AB	6" Upright Kit, 2-Pack, Black
9UPK4B	9" Upright Kit, 4-Pack, Black	9UPK4AB	9" Upright Kit, 4-Pack, Black
9UPK2B	9" Upright Kit, 2-Pack, Black	9UPK2AB	9" Upright Kit, 2-Pack, Black
RSK1B	Single Ratchet Upright Kit, 9", Black	RSK1AB	Single Ratchet Upright Kit, 9", Black

**Continued on Page 3**



**CATALOG NUMBER      **RRKFT****

**PRODUCT APPLICATION**

**This product is designed to be installed Ford Transit vans. HD Utility and Grip-Lock racks are not recommended for medium or high roof vehicles!**

**ACCESSORIES THAT WILL WORK WITH THIS PRODUCT**

CATALOG NUMBER	DESCRIPTION	CATALOG NUMBER	DESCRIPTION
<b>White Kit Part Numbers</b>		<b>Black Kit Part Numbers</b>	
<b>Grip-Lock Kits</b>			
GL-FSVDS	Driver Side Grip-Lock Kit, Full Size Van	GL-FSVDS-B	Driver Side Grip-Lock Kit, Full Size Van, Black
GL-FSVPS	Passenger Side Grip-Lock Kit, Full Size Van	GL-FSVPS-B	Passenger Side Grip-Lock Kit, Full Size Van, Black
<b>Standard Drop ProLift Kits</b>			
SDPLDS	Driver Side Standard Drop ProLift Kit, Full Size Van	SDPLDS-B	Driver Side Standard Drop ProLift Kit, Full Size Van, Black
SDPLPS	Passenger Side Standard Drop ProLift Kit, Full Size Van	SDPLPS-B	Passenger Side Standard Drop ProLift Kit, Full Size Van, Black
<b>Max Drop ProLift Kits</b>			
DDPLDS	Driver Side Max Drop ProLift Kit, Full Size Van	DDPLDS-B	Driver Side Max Drop ProLift Kit, Full Size Van, Black
DDPLPS	Passenger Side Max Drop ProLift Kit, Full Size Van	DDPLPS-B	Passenger Side Max Drop ProLift Kit, Full Size Van, Black
DDPLDSM	Driver Side Max Drop ProLift Kit, Full Size Van, Mid Roof	DDPLDSM-B	Driver Side Max Drop ProLift Kit, Full Size Van, Mid Roof, Black
DDPLPSM	Passenger Side Max Drop ProLift Kit, Full Size Van, Mid Roof	DDPLPSM-B	Passenger Side Max Drop ProLift Kit, Full Size Van, Mid Roof, Black
DDPLDSH	Driver Side Max Drop ProLift Kit, Full Size Van, High Roof	DDPLDSH-B	Driver Side Max Drop ProLift Kit, Full Size Van, High Roof, Black
DDPLPSH	Passenger Side Max Drop ProLift Kit, Full Size Van, High Roof	DDPLPSH-B	Passenger Side Max Drop ProLift Kit, Full Size Van, High Roof, Black
<b>Double Stack ProLift Kits</b>			
DSPLDS	Driver Side Double Stack ProLift Kit, Full Size Van	DSPLDS-B	Driver Side Double Stack ProLift Kit, Full Size Van, Black
DSPLPS	Passenger Side Double Stack ProLift Kit, Full Size Van	DSPLPS-B	Passenger Side Double Stack ProLift Kit, Full Size Van, Black



**CATALOG NUMBER      RRKFT**

**PRODUCT APPLICATION**

**This product is designed to be installed Ford Transit vans. HD Utility and Grip-Lock racks are not recommended for medium or high roof vehicles!**

**LADDER RACK HEIGHTS MEASURED FROM ROOF OF VEHICLE**

<b>CONFIGURATION</b>	<b>RACK HEIGHT LOW / MED / HIGH ROOF</b>
Base Rack	5.5" / 4.6" / 4.6"
Base + Ladder Stop	11.0" / 10.1" / 10.1"
Base + 4" Uprights	9.0" / 8.1" / 8.1"
Base + 6" Uprights	11.0" / 10.1" / 10.1"
Base + 9"/Ratchet Uprights	14.0" / 13.1" / 13.1"
Base + 4" PVC Conduit Kit	9.9" / 9.0" / 9.0"
Base + 6" PVC Conduit Kit	11.9" / 11.0" / 11.0"
Base + Aluminum Box Conduit Kit	12.0" / 11.2" / 11.2"
Base + Grip-Lock	12.2" / (N/A) / (N/A)
Base + Standard Drop ProLift	12.5" / (N/A) / (N/A)
Base + Max Drop ProLift	14.0" / 13.1" / 13.1"
Base + Double Stack ProLift	Coming Soon!

INSTR. NUMBER : <b>67267</b>	PG: <b>1</b>	REV: <b>E</b>	ITEM NO.	PART NUMBER	DESCRIPTION	QTY.
	PART NUMBER : <b>RRKFT</b>			1	63477	ROOF RAIL, FORD TRNST FSV
PART DESC. : ROOF RAIL KIT FT FSV			2	52709	SPACER-PAD .25 TRANSIT LR LDRK	6

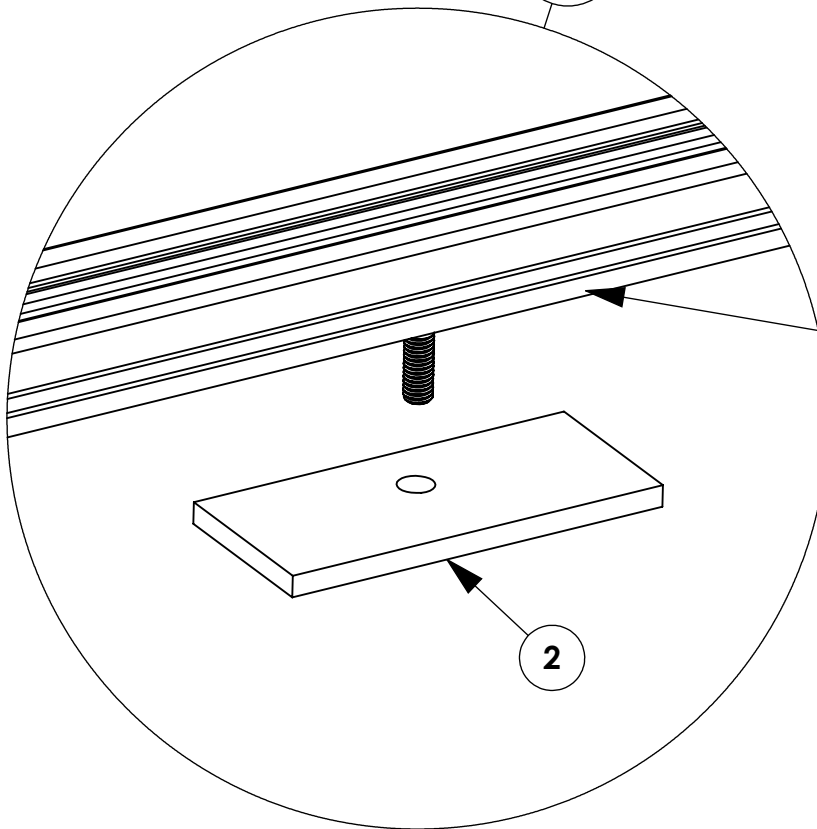
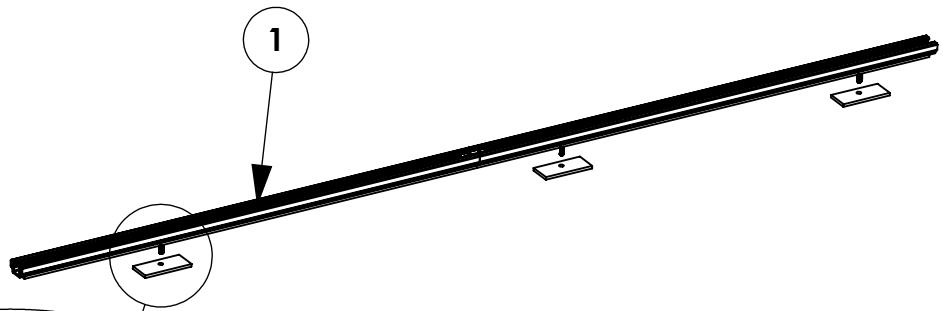
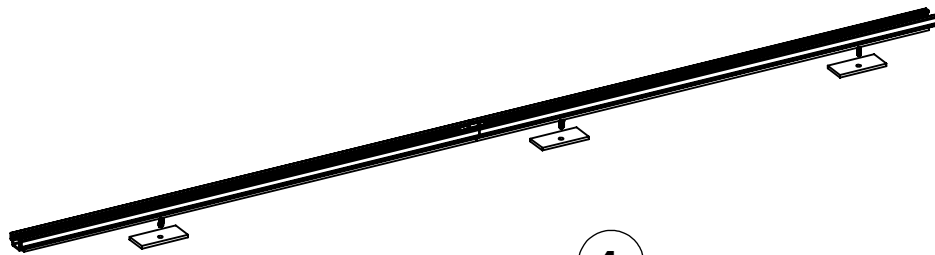

**ATTENTION!**

PLEASE VERIFY THAT FOAM TAPE HAS BEEN INCLUDED ON THE BOTTOM OF EACH RAIL.

DO NOT INSTALL RAILS IF THE FOAM TAPE IS MISSING!

**TOOLS NEEDED:**

- DRIVE RATCHET
- IMPACT DRIVER
- 13mm SOCKET
- 5/32" HEX DRIVE
- M8-1.25 TAP
- TAPE MEASURE

**GET TO KNOW THE VEHICLE** - AT THE BEGINNING OF ANY INSTALLATION, CHECK THE LOCATION OF THE FUEL TANK, FUEL LINES, BRAKE LINES, HIGH VOLTAGE BATTERIES AND WIRING HARNESSSES TO AVOID INJURY OR PROPERTY DAMAGE FROM TOOL CONTACT.

**SEAL ALL EXTERIOR HOLES** - ALL INSTALLATION HOLES SHOULD BE SEALED WITH BUTYL TAPE OR SILICON TO PREVENT WATER AND EXHAUST GASES FROM ENTERING THE VEHICLE.

**CONTROL DRILL DEPTH** - TO AVOID DAMAGE TO THE VEHICLE, USE A DRILL STOP OR CLEARED STEP BIT WHEN DRILLING INSTALLATION HOLES.

**ALWAYS ADD PRIMER** - WHEN ADDING INSTALLATION HOLES BE SURE TO USE A SELF-ETCHING PRIMER TO PREVENT CORROSION, FASTENER FAILURE AND INJURY.

**MOUNTING POINTS MUST HAVE METAL-TO-METAL CONTACT** - USE PROVIDED MOUNTING SPACERS TO ACCOMMODATE FOR VEHICLE FEATURES, CARPET OR SUBFLOORS.

**PROVIDE CLEARANCE FOR SPACERS** - IF THE INSTALLATION VEHICLE CONTAINS A CARPET OR SUBFLOOR, USE A 1-3/16" DIAMETER CARPET CUTTER (P/N: 31183-0) AT ALL MOUNTING LOCATIONS TO OPEN UP ROOM FOR SPACERS.

**CHECK SPACER ORIENTATION** - BE SURE THAT THE INDENT IN THE SPACER COVERS THE PLUSNUT HEAD; THIS ENSURES THE MOST METAL-TO-METAL CONTACT AND REDUCES VIBRATION.

**PLUSNUT INSTALLATION** - A PLUSNUT GUN IS RECOMMENDED FOR PLUSNUT INSTALLATION FOR ITS PRODUCTION SPEED. HOWEVER, A PLUSNUT SETTING TOOL CAN ALSO BE USED (P/N: 22200-0).

**THRU-BOLT CLEARANCE** - WHEN USING A THRU-BOLT AT ANY MOUNTING LOCATION, BE SURE THAT YOUR HOLE HAS 1/16" CLEARANCE.

**FASTENERS AND HARDWARE USED**

**BAG REFERENCE: BAGRRKFTM & BAG63411**

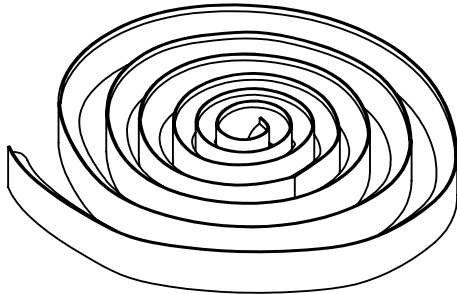

05586-0  
BUTYL TAPE  
1FT ROLL  
QTY: 1

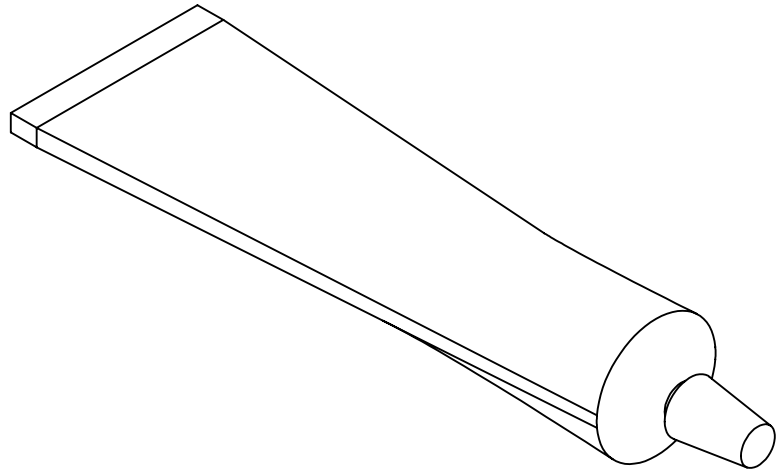

26618-0  
SILICONE  
1OZ TUBE  
QTY: 1

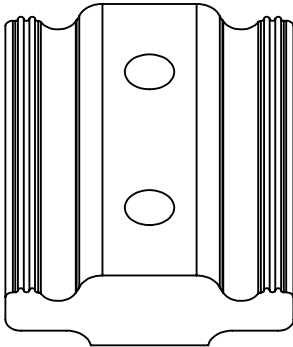

63491  
RAIL CONNECTOR, 2"  
QTY: 2

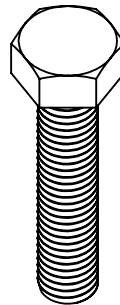

FAS0351  
SCREW, HH SS  
M8-1.25X40  
QTY: 6

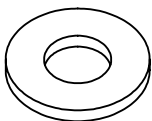

FAS0552  
WASHER, FLAT  
5/16 SS  
QTY: 6



FAS0497  
SCREW, SET  
5/16-18X.75 SS  
QTY: 4

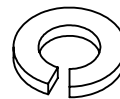

FAS0588  
WASHER, LCK  
SPLIT 5/16 SS  
QTY: 6

**PAGE INTENTIONALLY LEFT BLANK**

**STEP 1 - ASSEMBLE ROOF RAILS**

**STEP 1.1**  
**FULLY TIGHTEN**  
**63491, (02) FAS0497**  
**(02 PLACES)**  
**5/32" HEX DRIVE**

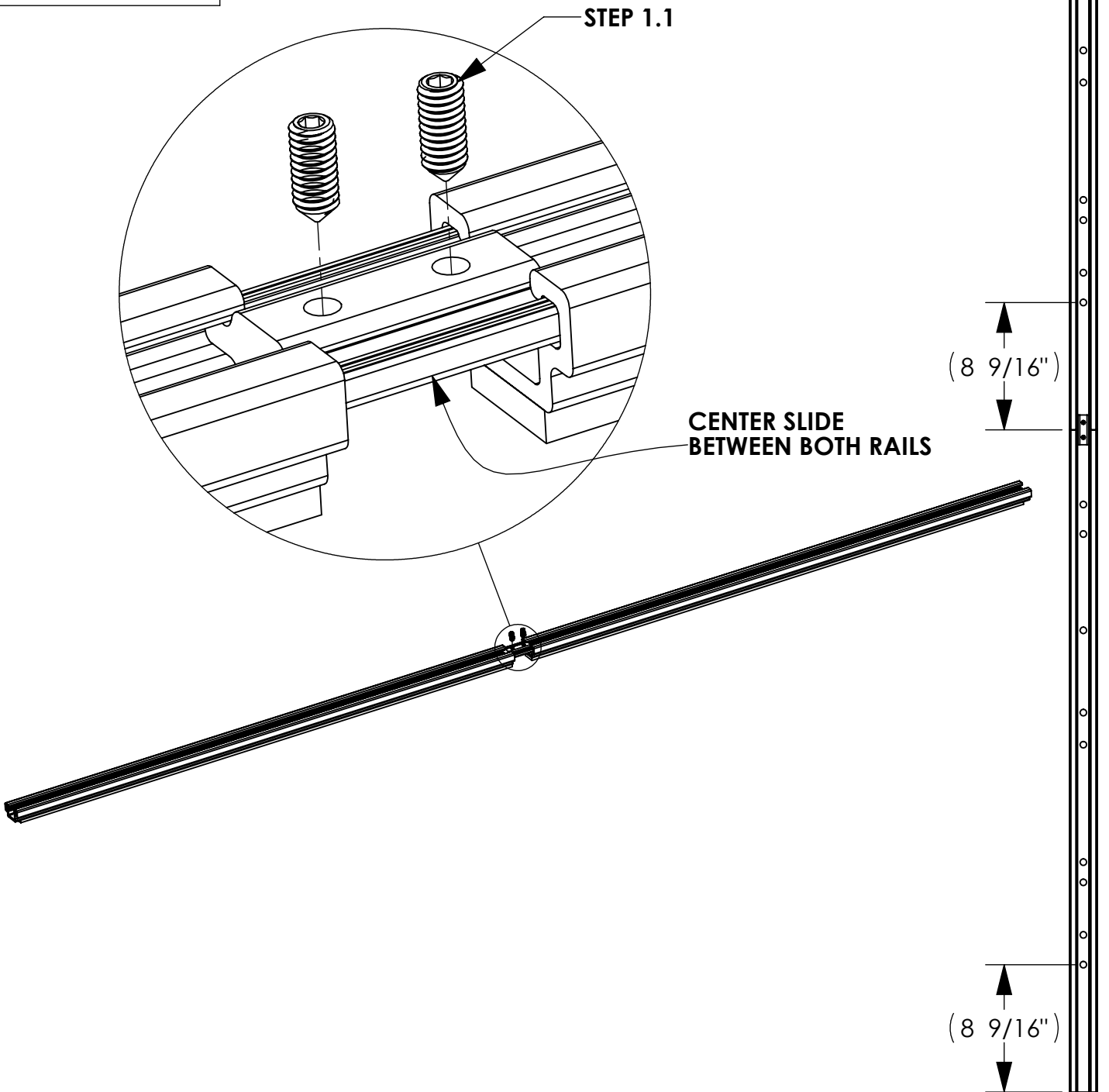

**STEP 2 - INSTALL ROOF RAILS ONTO VEHICLE ROOF**

**STEP 2.1  
REMOVE OEM  
PLASTIC PLUG**

USE M8-1.25 TAP  
TO CLEAR THREAD  
OF OEM WELD NUT  
(IF NECESSARY)

ROOF HOLE  
CLEARANCING  
MAY BE  
NECESSARY DO TO  
OEM ROOF  
TOLERANCE

**STEP 2.2  
FULLY TIGHTEN  
FAS0351, FAS0552,  
FAS0588  
(06 PLACES)  
13mm SOCKET**

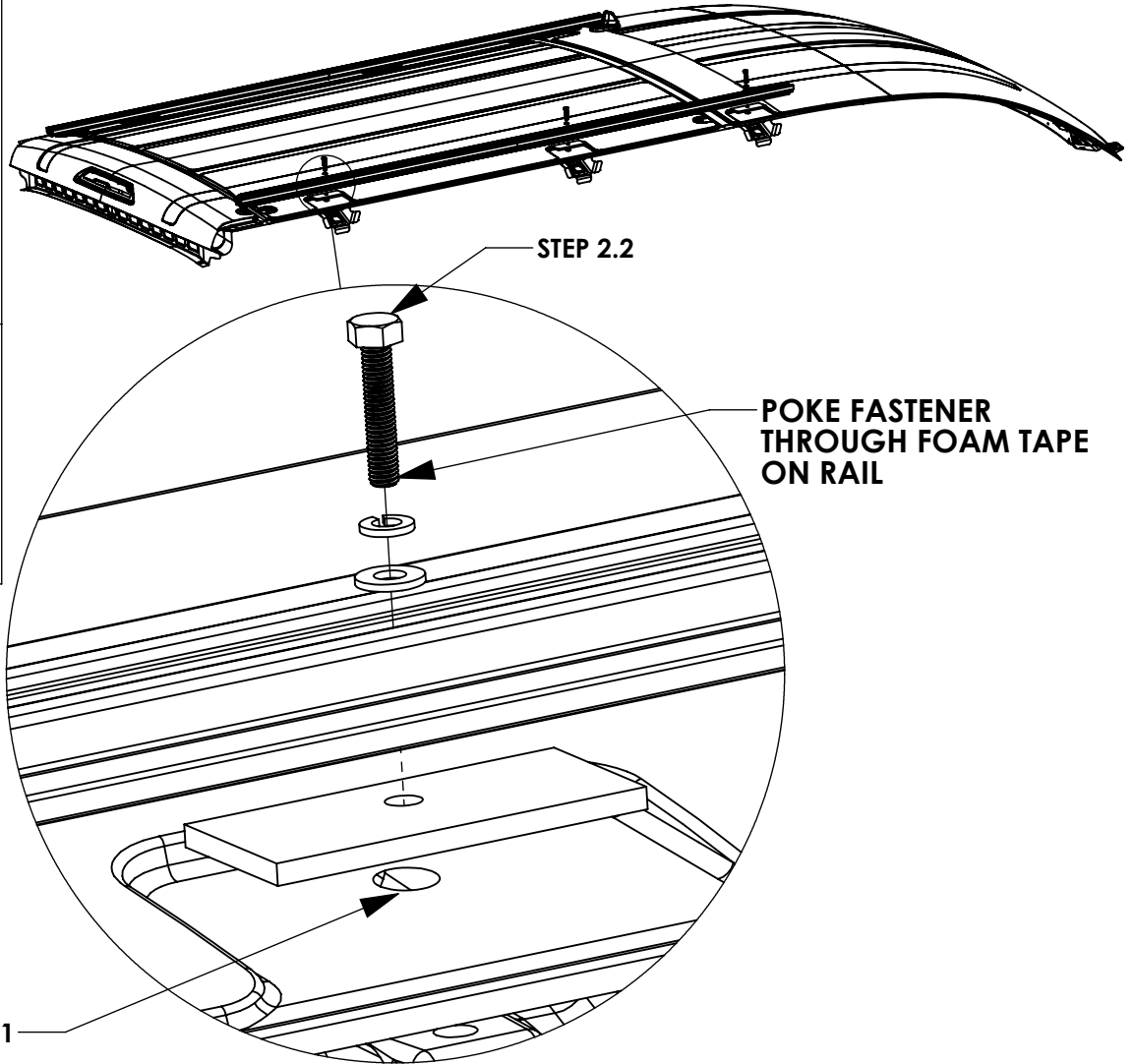

**ADD SILICONE TO FILL CAVITY OF EACH OEM WELD NUT IN  
VEHICLE ROOF AND BUTYL TAPE UNDER WASHERS ON BOLT**

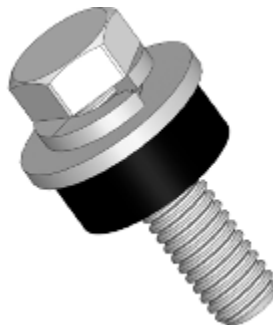

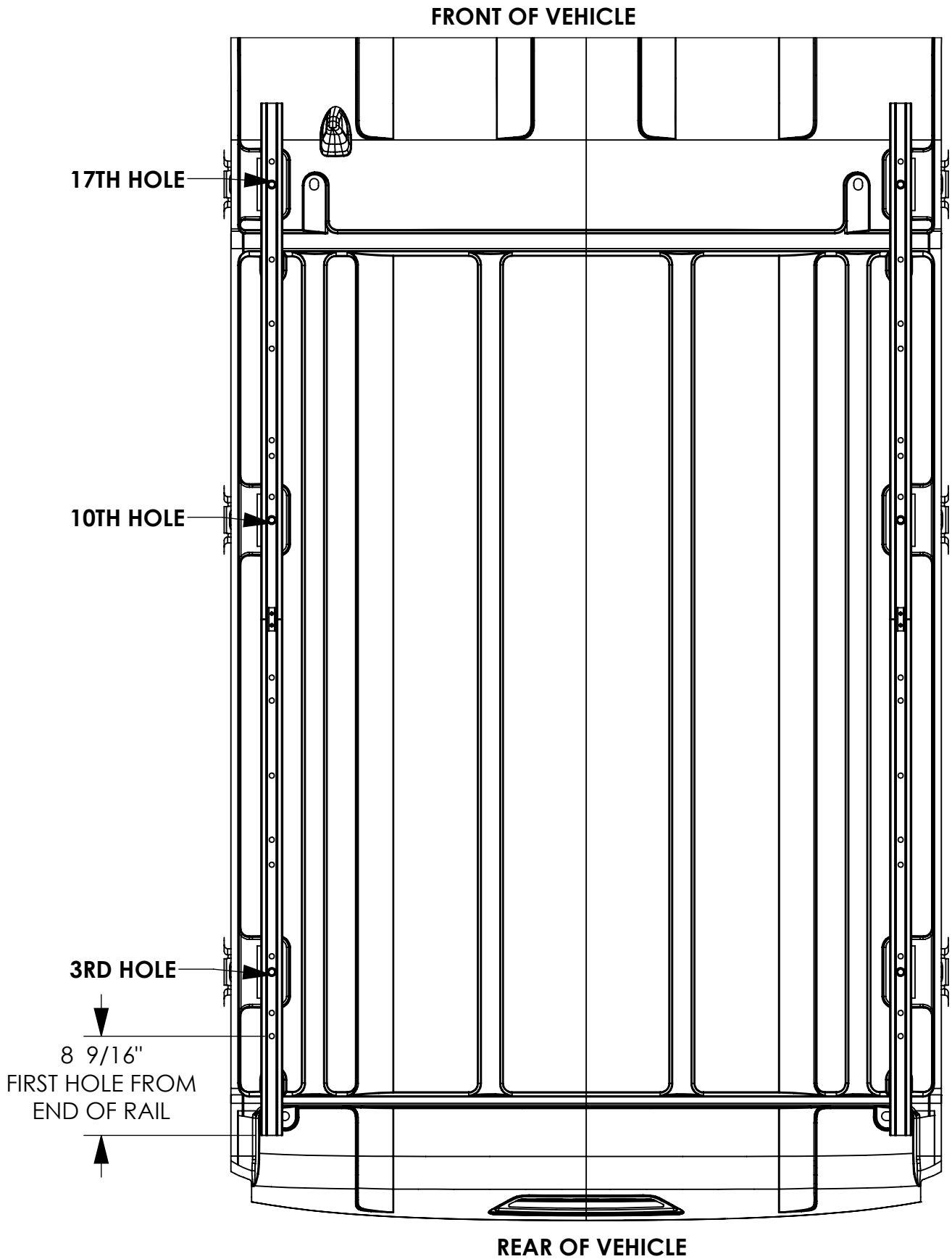

ROOF RAIL INSTALL LOCATION - 148" WHEELBASE

FRONT OF VEHICLE

15TH HOLE

7TH HOLE

2ND HOLE

8 9/16"  
FIRST HOLE FROM  
END OF RAIL

REAR OF VEHICLE

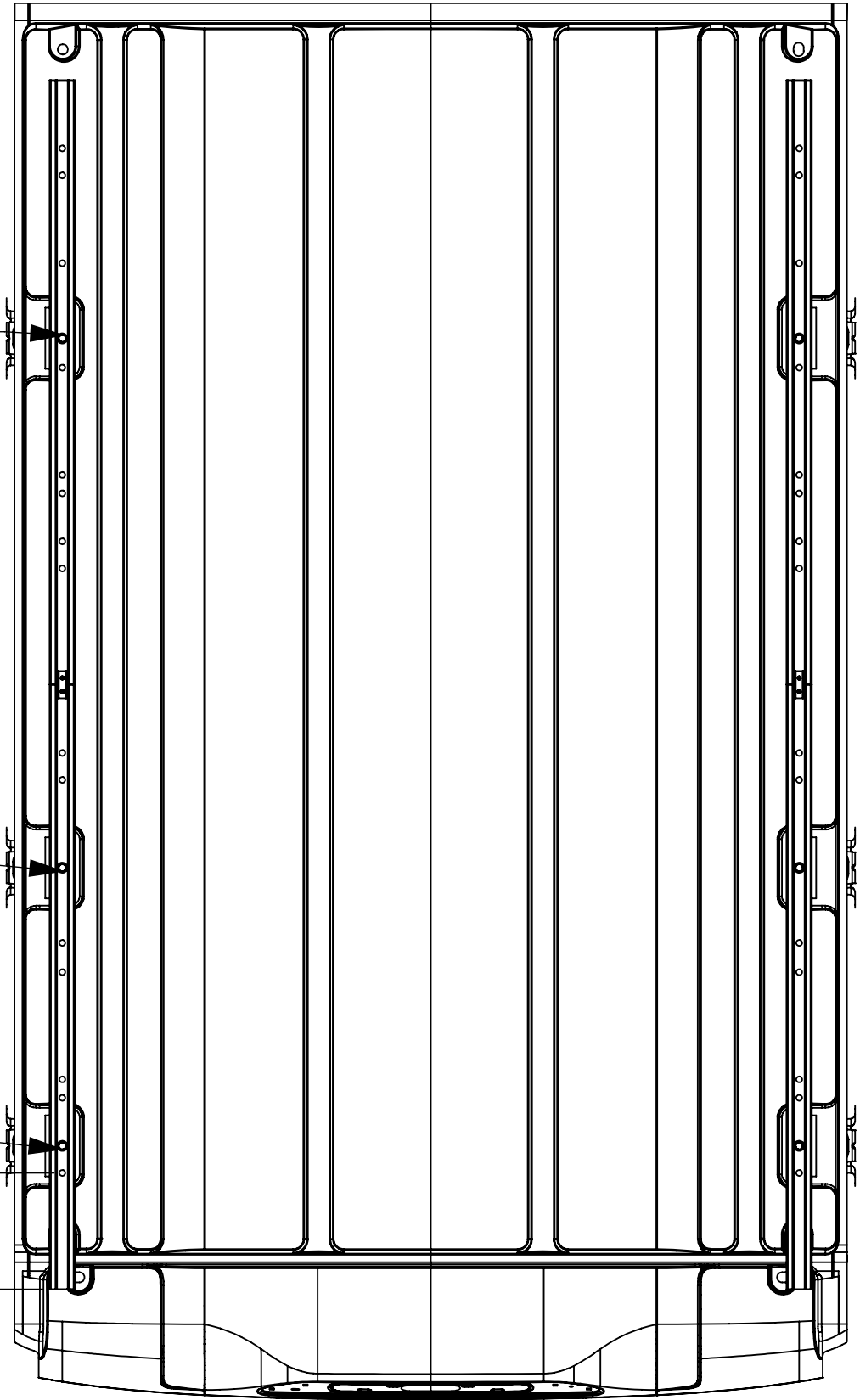

**ROOF RAIL INSTALL LOCATION - 148" EXTENDED WHEELBASE**

FRONT OF VEHICLE

13TH HOLE

9TH HOLE

5TH HOLE

8 9/16"  
FIRST HOLE FROM  
END OF RAIL

REAR OF VEHICLE

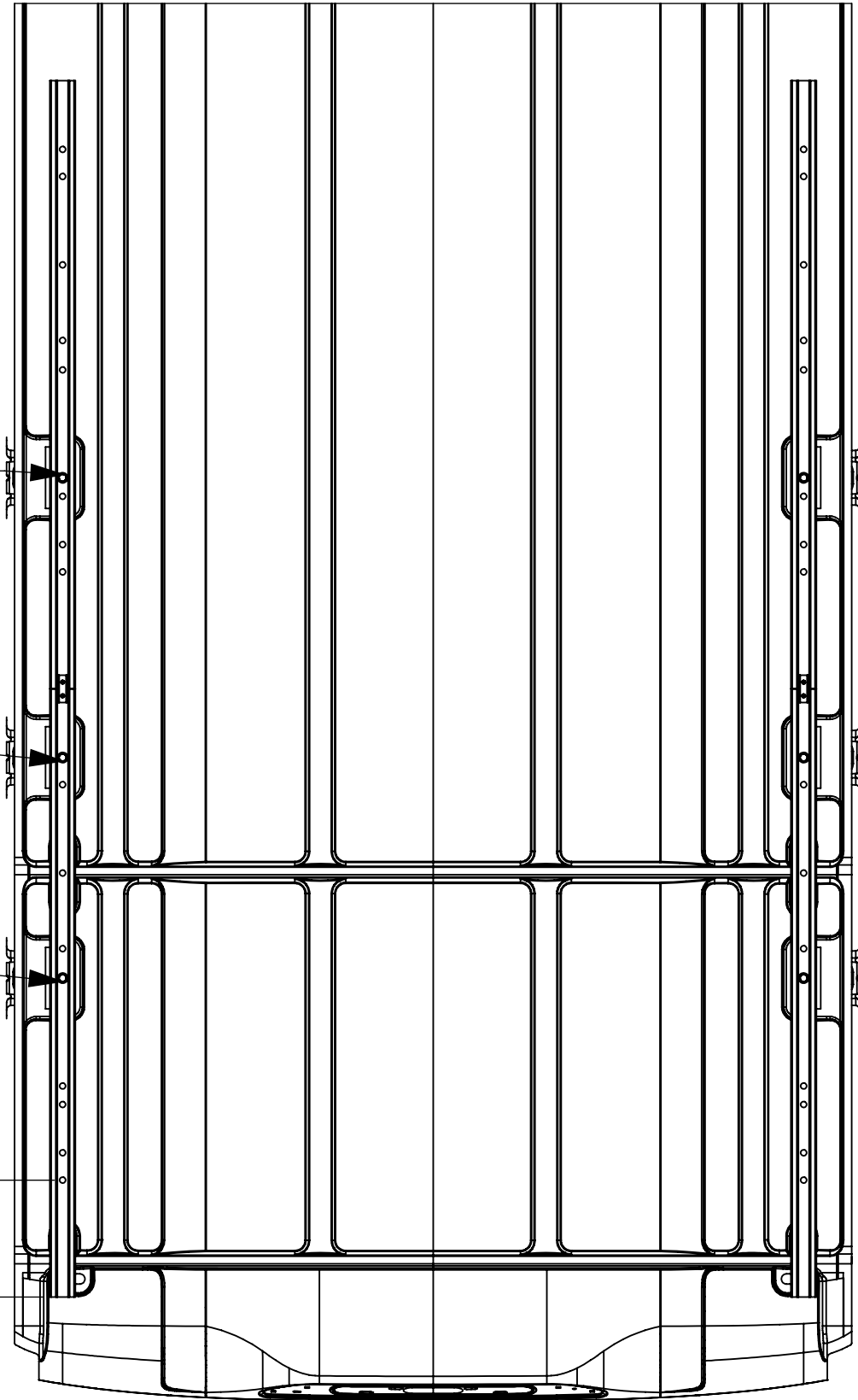



## Mounting Bracket Kit, 4-Pack, White, Multiple Pickups

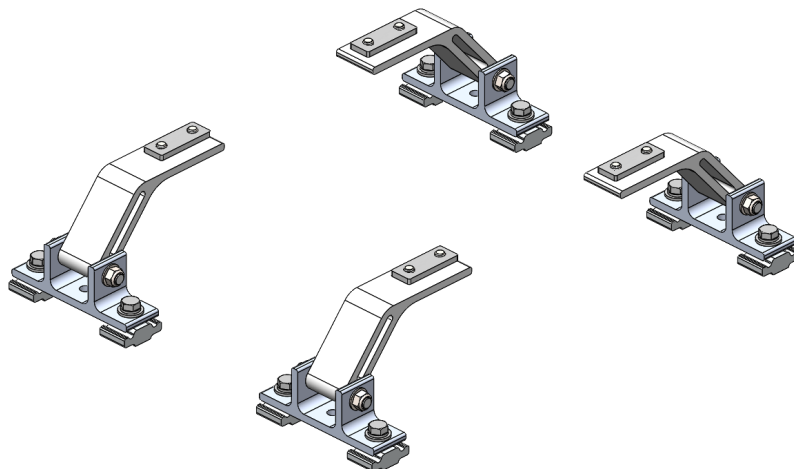

PRODUCT WEIGHT  
**4.0 LBS**

HEIGHT OFF ROOF  
**SEE TABLE BELOW**

CAPACITY  
**REFER TO OEM'S  
RECOMMENDED LOAD  
RATING**  
COLOR

**WHITE**

CATALOG NUMBER

**URMBK4W**

### PRODUCT FEATURES

**Aluminum mounting bracket kit for the PROFILE™ HD Utility, Grip-Lock, and/or ProLift ladder racks. Only works with the OEM specific, Adrian Steel supplied roof rail kit.**

**Utility and Grip-Lock racks are not recommended for medium or high roof vehicles!**

**Reference respective OEM specific roof rail kit for more detailed list of compatible accessories.**

**SEE PAGE 2 FOR APPLICATION NOTES AND ACCESSORIES, OTHER PRODUCTS THAT WORK WITH THIS UNIT.**

### PAGE 1 of 2

The information contained in this document is the sole property of ADRIAN STEEL COMPANY. ADRIAN STEEL COMPANY retains the right to modify and/or change the product of its design at any time without prior notification.



**CATALOG NUMBER URMBK4W**

**PRODUCT APPLICATION**

**This product is designed to work with OEM specific rail kit for HD Utility, Grip-Lock, and/or ProLift racks. HD Utility and Grip-Lock racks are not recommended for medium or high roof vehicles!**

**ACCESSORIES THAT WILL WORK WITH THIS PRODUCT**

CATALOG NUMBER	DESCRIPTION	CATALOG NUMBER	DESCRIPTION
RRKFT	Mounting Roof Rail Kit, Transit	RRKNVFSV	Mounting Roof Rail Kit, NV
RRKSP	Mounting Roof Rail Kit, Sprinter	RRKPM	Mounting Roof Rail Kit, ProMaster, 118" WB, 159" WB, 159" WB Extended
RRKPM136WB	Mounting Roof Rail Kit, ProMaster, 136" WB	RRKSBTOP	Mounting Roof Rail Kit, Multiple Pickups
RRKLBTOP	Mounting Roof Rail Kit, Multiple Pickups		

**Reference respective OEM specific roof rail kit for more detailed list of compatible accessories.**

INSTR. NUMBER : <b>66850</b>	PG: <b>1</b>	REV: <b>E</b>	ITEM NO.	PART NUMBER	DESCRIPTION	URMBK4W	URMBK2W
	PART NUMBER : <b>URMBK</b>		1	65123-W	UTILITY, FT MOUNT ARM, ST, W	4	2
PART DESC. : UTILITY, MNT BKT KT, RAIL			2	63852-W	UTILITY, MOUNTING BRKT, W	4	2

**-PART NUMBERS WITH "-W" SUFFIX ARE PAINTED WHITE  
-FOR BLACK MOUNTING KITS, REPLACE "-W" PARTS WITH "-B" PARTS**

**NOTE: THIS INSTRUCTION IS VALID FOR THE FOLLOWING KITS:**

- URMBK4W
- URMBK4B
- URMBK2W
- URMBK2B

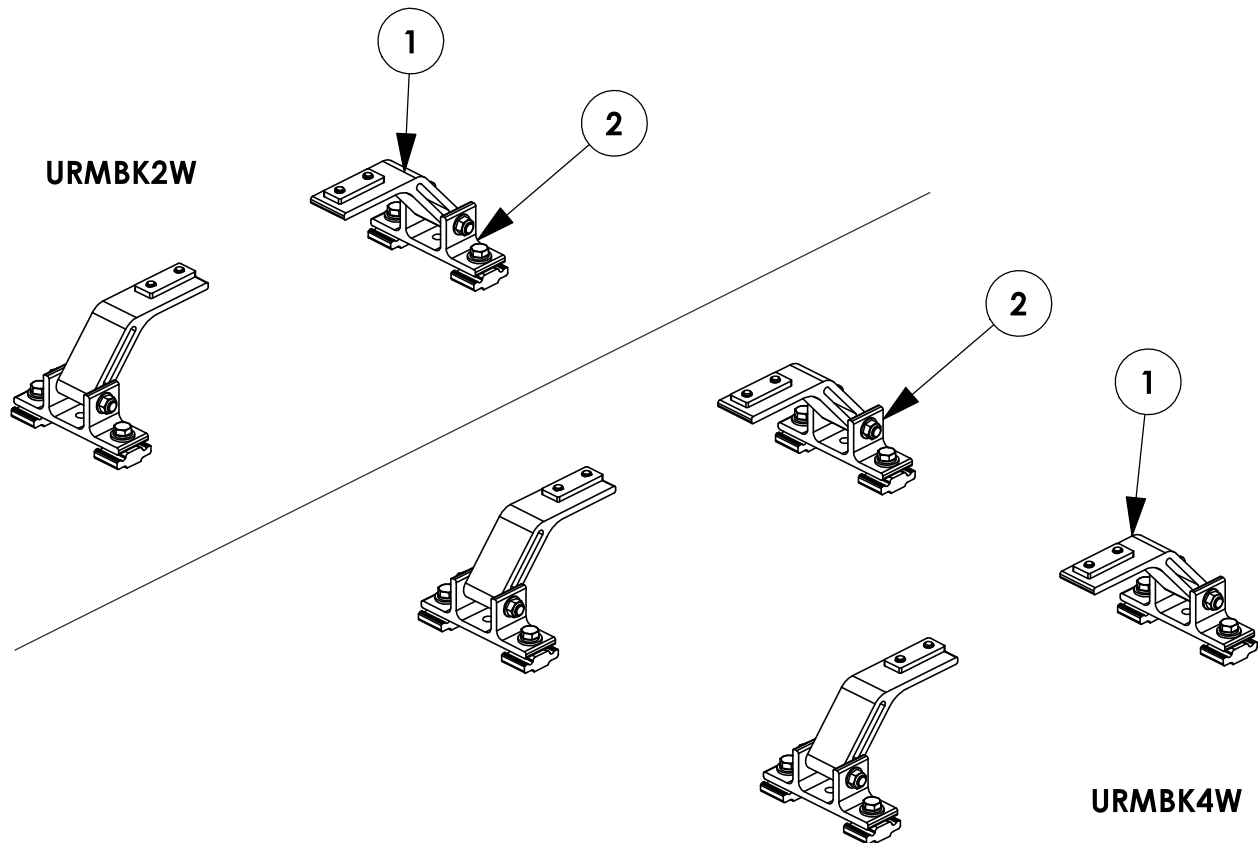

**TOOLS NEEDED:**

- DRIVE RATCHET
- IMPACT DRIVER
- 3/16" SOCKET
- 1/2" SOCKET
- 1/2" WRENCH
- TAPE MEASURE

**GET TO KNOW THE VEHICLE** - AT THE BEGINNING OF ANY INSTALLATION, CHECK THE LOCATION OF THE FUEL TANK, FUEL LINES, BRAKE LINES, HIGH VOLTAGE BATTERIES AND WIRING HARNESSSES TO AVOID INJURY OR PROPERTY DAMAGE FROM TOOL CONTACT.

**SEAL ALL EXTERIOR HOLES** - ALL INSTALLATION HOLES SHOULD BE SEALED WITH BUTYL TAPE OR SILICON TO PREVENT WATER AND EXHAUST GASES FROM ENTERING THE VEHICLE.

**CONTROL DRILL DEPTH** - TO AVOID DAMAGE TO THE VEHICLE, USE A DRILL STOP OR CLEARED STEP BIT WHEN DRILLING INSTALLATION HOLES.

**ALWAYS ADD PRIMER** - WHEN ADDING INSTALLATION HOLES BE SURE TO USE A SELF-ETCHING PRIMER TO PREVENT CORROSION, FASTENER FAILURE AND INJURY.

**MOUNTING POINTS MUST HAVE METAL-TO-METAL CONTACT** - USE PROVIDED MOUNTING SPACERS TO ACCOMMODATE FOR VEHICLE FEATURES, CARPET OR SUBFLOORS.

**PROVIDE CLEARANCE FOR SPACERS** - IF THE INSTALLATION VEHICLE CONTAINS A CARPET OR SUBFLOOR, USE A 1-3/16" DIAMETER CARPET CUTTER (P/N: 31183-0) AT ALL MOUNTING LOCATIONS TO OPEN UP ROOM FOR SPACERS.

**CHECK SPACER ORIENTATION** - BE SURE THAT THE INDENT IN THE SPACER COVERS THE PLUSNUT HEAD; THIS ENSURES THE MOST METAL-TO-METAL CONTACT AND REDUCES VIBRATION.

**PLUSNUT INSTALLATION** - A PLUSNUT GUN IS RECOMMENDED FOR PLUSNUT INSTALLATION FOR ITS PRODUCTION SPEED. HOWEVER, A PLUSNUT SETTING TOOL CAN ALSO BE USED (P/N: 22200-0).

**THRU-BOLT CLEARANCE** - WHEN USING A THRU-BOLT AT ANY MOUNTING LOCATION, BE SURE THAT YOUR HOLE HAS 1/16" CLEARANCE.

**FASTENERS AND HARDWARE USED**

**BAG REFERENCE: BAG66848**

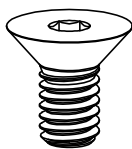

**FAS0858**  
**5/16-18X.63**  
**FHH SCREW**  
**QTY: 8**

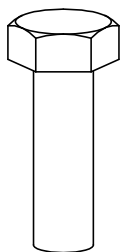

**FAS0597**  
**5/16-18X1.0 SS**  
**HH SCREW**  
**QTY: 8**

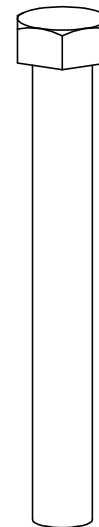

**FAS0243**  
**5/16-18X2.5 SS**  
**HH SCREW**  
**QTY: 4**



**FAS0857**  
**5/16 SS WASHER,**  
**LOCK EXT CS**  
**QTY: 8**



**FAS0588**  
**5/16 SS**  
**SPLIT WASHER**  
**QTY: 8**



**FAS0552**  
**5/16 SS**  
**FLAT WASHER**  
**QTY: 12**

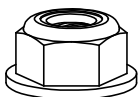

**FAS0861**  
**5/16-18 SS**  
**HH FLG NUT**  
**QTY: 4**

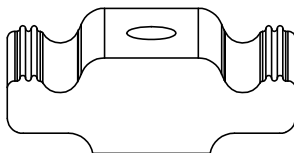

**63490**  
**RAIL SLIDE,**  
**1"**  
**QTY: 8**

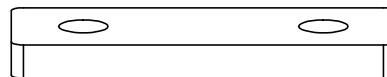

**68042**  
**PROFILE FOOT**  
**MOUNTING PLATE**  
**QTY: 4**

**PAGE INTENTIONALLY LEFT BLANK**

# STEP 1 - ASSEMBLE MOUNTING ARMS TO CROSSBOW



CHECK TABLE 1-3 IN INSTRUCTION 68895 FOR ADDITIONAL ACCESSORY SLIDE INSTALLATION BEFORE INSTALLING MOUNTING BRACKETS (ALL A.2 ITEMS SHOULD BE COMPLETELY ASSEMBLED FIRST!)

STEP 1.1  
LOOSELY ASSEMBLE  
UNTIL AFTER STEP 3  
(2) FAS0857, (2)  
FAS0858, 68042

(02 PLACES PER  
CROSSBOW)  
3/16" ALLEN

## ATTENTION!

IF INSTALLING A GRIP-LOCK ON A PICKUP TRUCK TOPPER, ASSEMBLE MOUNTING ARMS FACING OUTWARD FOR THAT SIDE OF THE RACK

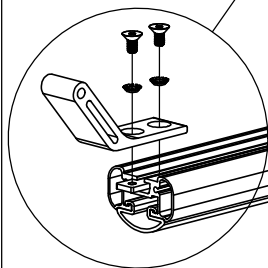
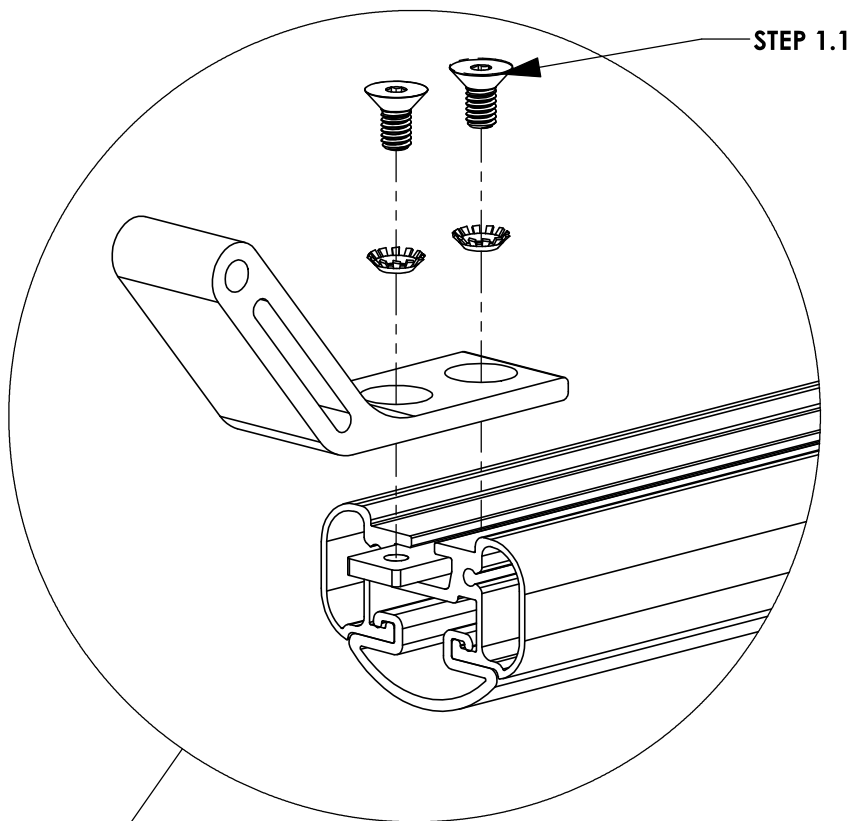

SLIDES AND FASTENERS WILL BE INCLUDED IN THEIR RESPECTIVE KITS. THESE SHOULD BE INSERTED PRIOR TO ASSEMBLING MOUNTING ARMS!

**STEP 2 - SECURE CROSSBOW**

**FULL SIZE VANS**

**CENTER CROSSBOW ON MOUNTING BRACKETS**

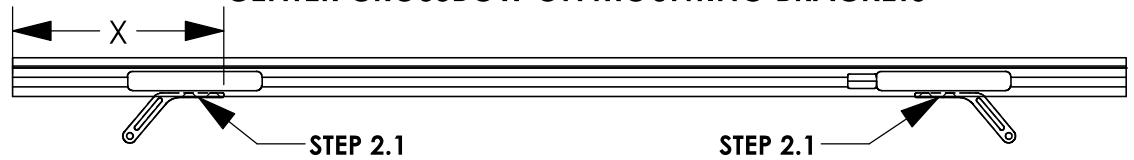

**STEP 2.1**  
**FULLY TIGHTEN**  
**FROM STEP 1.1**  
  
 (04 PLACES PER  
 CROSSBOW)  
 3/16" ALLEN

VEHICLE PLATFORM	DIMENSION "X" (in.) - 58" CROSSBOW	DIMENSION "X" (in.) - 68" CROSSBOW
FORD TRANSIT	6 5/8"	11 5/8"
RAM PROMASTER	6"	11"
NISSAN NV	4 7/8"	9 7/8"
MERCEDES SPRINTER (LOW ROOF)	4 5/8"	9 5/8"
MERCEDES SPRINTER (HIGH ROOF)	8 1/8"	13 1/8"

**DIMENSION WILL VARY BASED ON ROOF RAIL PLACEMENT ON TOPPER**

**PICKUP TRUCK TOPPERS**

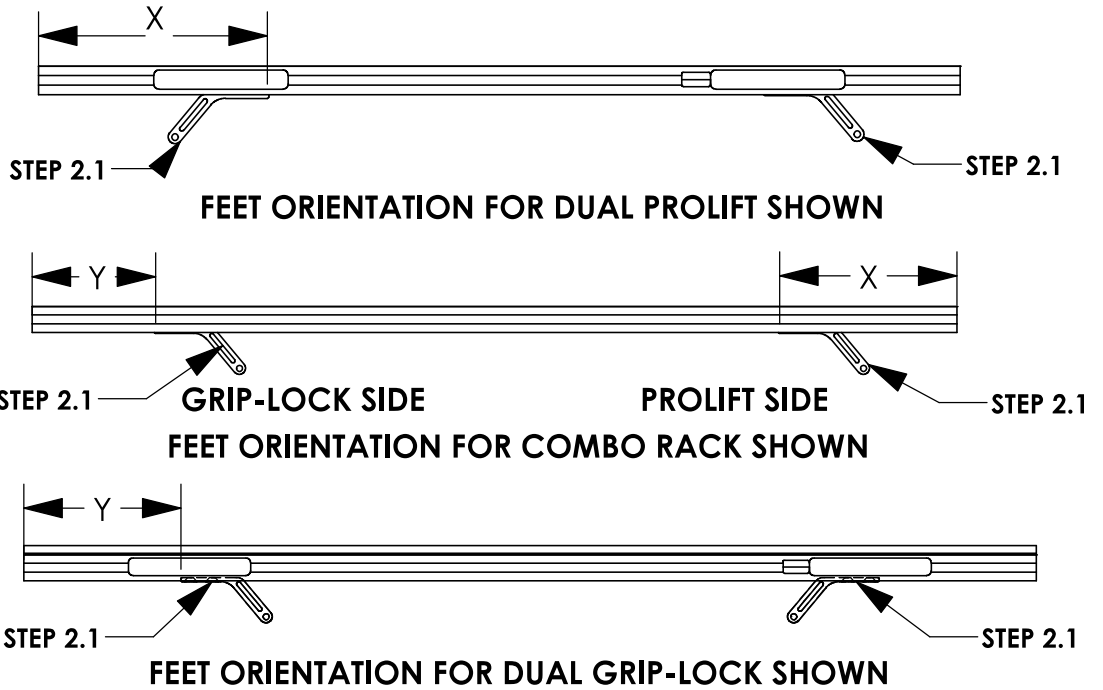

**MOUNTING FEET FOR GRIP LOCK SIDE OF COMBO RACK WILL FACE OUTWARD FROM ROOF CENTERLINE ON TOPPER**

CROSSBOW LENGTH	DIMENSION "X" (in.) - PROLIFT	DIMENSION "Y" (in.) - GRIPLOCK
48" (PROLIFT)	MINIMUM 10 1/8"	N/A
53" (COMBO)	MINIMUM 10 1/8"	MAX 7 1/8"
58" (GRIP-LOCK)	N/A	MAX 7 1/8"

**NOTE - THESE DIMENSIONS ARE APPROXIMATE AND WILL VARY SLIGHTLY WITH ANY TOLERANCE IN THE BUILD OF THE VEHICLE**

**STEP 3 - ASSEMBLE LOWER MOUNTING FOOT TO ROOF RAIL**

**STEP 3.1**  
**FULLY TIGHTEN**  
 FAS0597, FAS0552,  
 FAS0588, 63490 ON  
 REAR MOUNTING FEET

(02 PLACES PER  
 MOUNTING FOOT)  
 1/2" SOCKET

**STEP 3.2**  
**LEAVE LOOSE UNTIL**  
**AFTER STEP 4**  
 FAS0597, FAS0552,  
 FAS0588, 63490 ON  
 FRONT MOUNTING  
 FEET

(02 PLACES PER  
 MOUNTING FOOT)  
 1/2" SOCKET

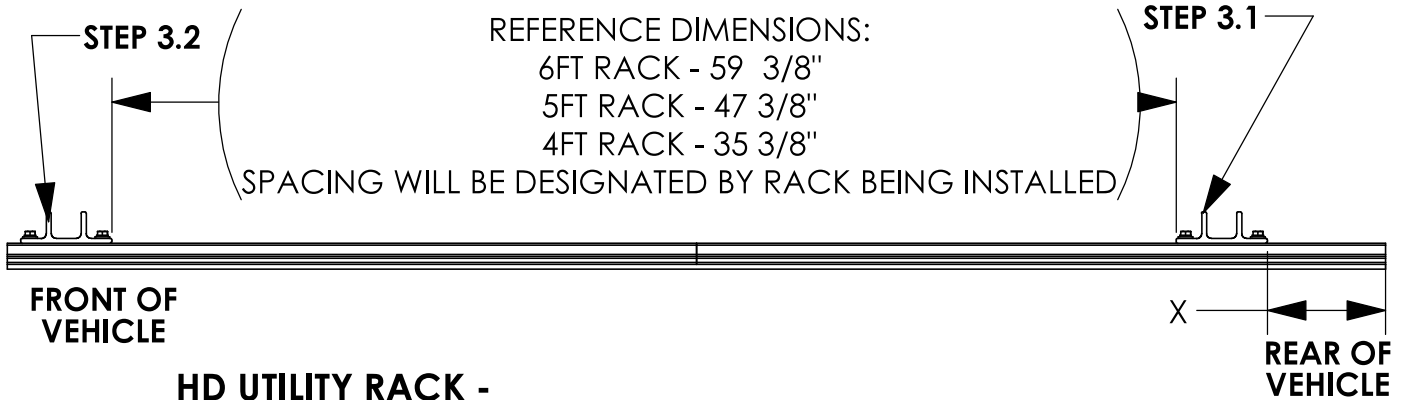
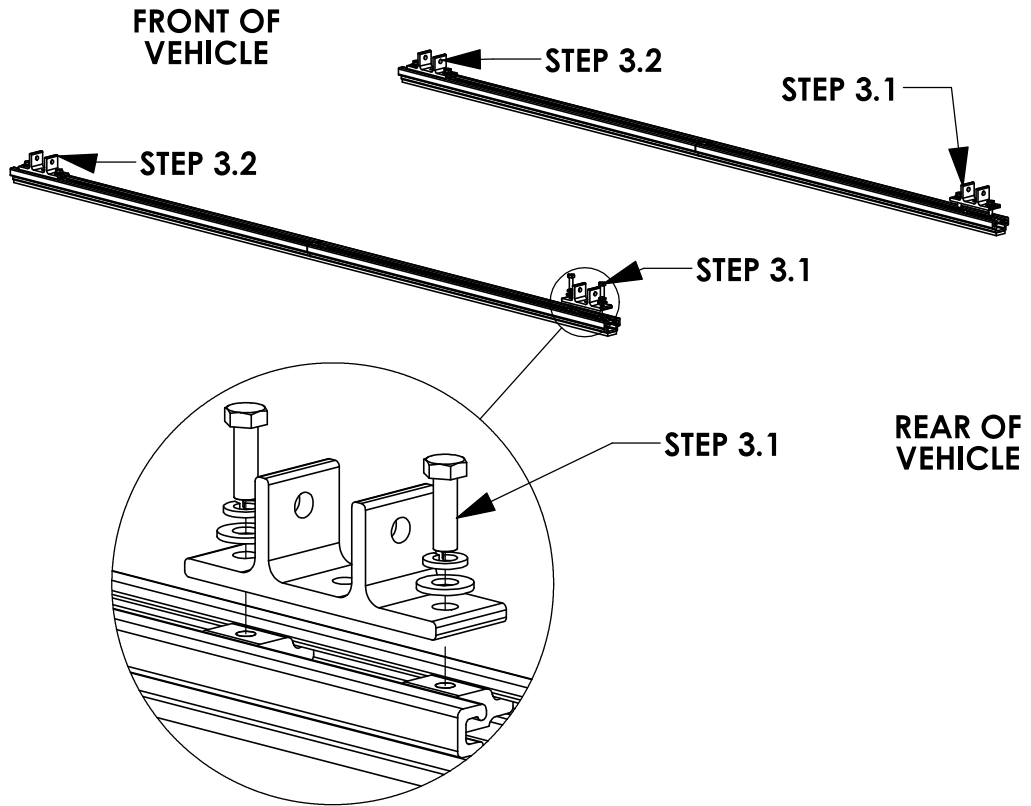

**HD UTILITY RACK -**

**REAR CROSSBOW - REARWARD AS POSSIBLE**

**FRONT CROSSBOW- POSITION TO BEST FIT END USER'S PRODUCT**

FORD TRANSIT		RAM PROMASTER		MERCEDES SPRINTER	
ROOF HEIGHT/ WHEELBASE	POSITION X (IN)	ROOF HEIGHT/ WHEELBASE	POSITION X (IN)	ROOF HEIGHT/ WHEELBASE	POSITION X (IN)
LOW ROOF	7.5	LR 118	10	LR 144	10.5
MID ROOF	7.5	LR 136	10	HR 144	12.5
HIGH ROOF	7.5	HR 136	10	HR 170	12.5
HIGH ROOF EXT	7.5	HR 159/159 EXT	10	HR 170 EXT	12.5

# STEP 4 - ASSEMBLE MOUNTING BRACKETS TO MOUNTING ARMS



**BEFORE PROCEEDING WITH THIS STEP FINISH ASSEMBLING ACCESSORIES ONTO RACK. (IE GRIP LOCK, PROLIFT, ETC)**

## STEP 4.1

### FULLY TIGHTEN

FAS0243, FAS0552,  
FAS0861

(02 PLACES PER  
CROSSBOW)

1/2" SOCKET  
1/2" WRENCH

## STEP 4.2

### FULLY TIGHTEN

FAS0597, FAS0552,  
FAS0588, 63490 ON  
FRONT MOUNTING  
FEET

(02 PLACES PER  
MOUNTING FOOT)

1/2" SOCKET

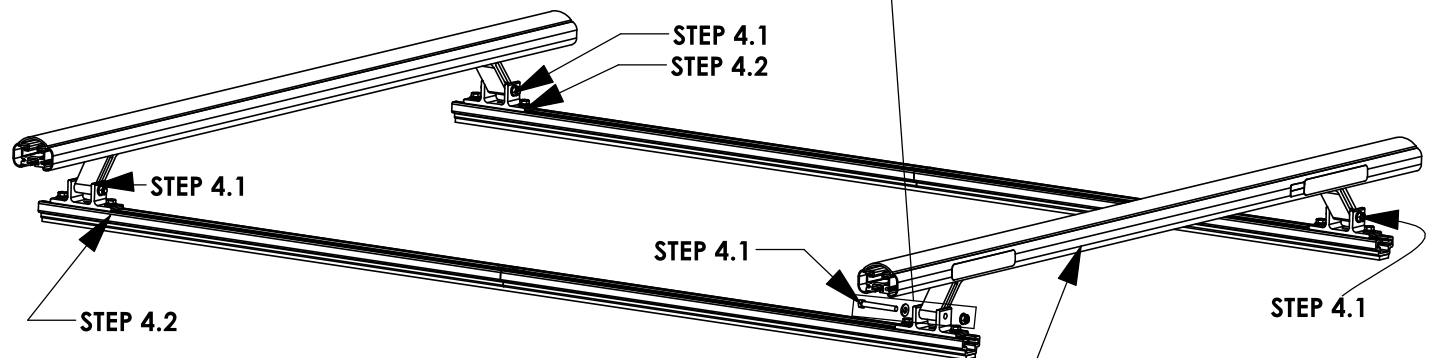
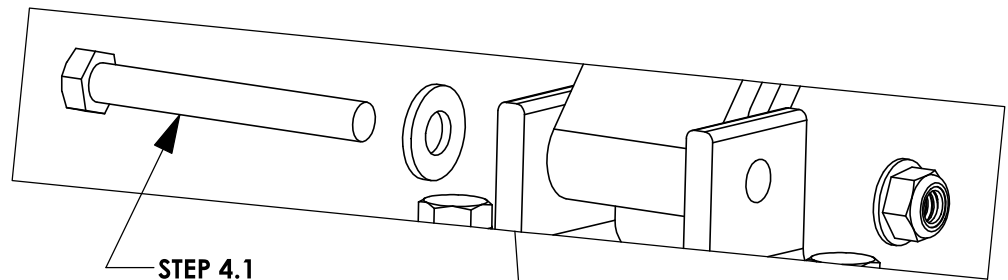

**NOTE ORIENTATION OF LABELS ON CROSSBOW**

REFERENCE - NO ACCESSORIES SHOWN

**STEP 5 - ADJUST MOUNTING BRACKET LOCATION IF NECESSARY**

**CROSSBOW POSITIONING NOTES:**

**HD UTILITY RACK -**

REAR CROSSBOW - REARWARD AS POSSIBLE  
 FRONT CROSSBOW- POSITION TO BEST FIT END USER'S PRODUCT

**GRIP LOCK/PROLIFT LADDER RACKS -**

1/2" FROM END OF RAIL UNLESS OTHERWISE STATED IN RESPECTIVE INSTRUCTION FOR CROSSBOW PLACEMENT.

**6' ARE TOPPER / 8' LEER TOPPER**

**A** OPTIMAL RAIL KIT POSITION:  
 TOPPER ROOF RAIL KIT END TO BE  
 A-DIM FROM BLACK TOPPER TRIM

**B** UTILITY MOUNTING BRACKET:  
 REAR MOUNTING BRACKETS WILL  
 BE B-DIM FROM THE END OF THE  
 ROOF RAIL KIT

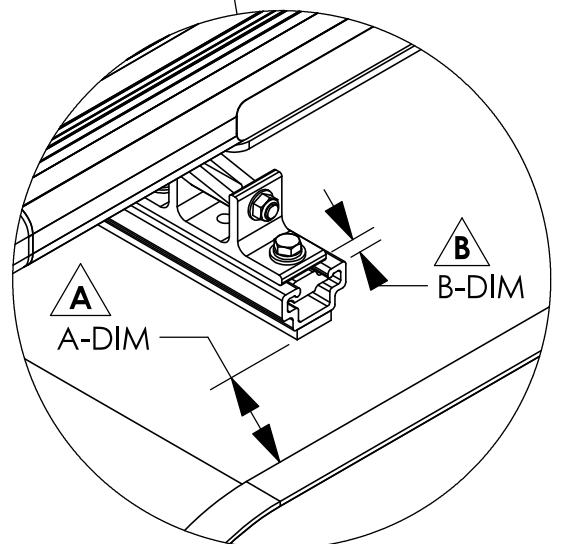
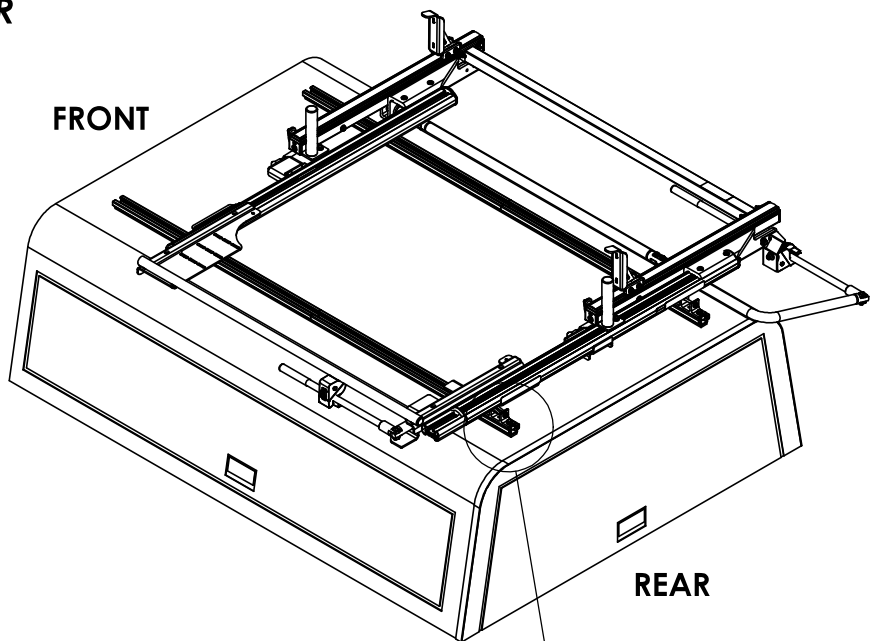

TOPPER/ DIMENSION	6' ARE TOPPER	8' LEER TOPPER
A-DIM	3.00"	1.00"
B-DIM	0.50"	0.50"

**NOTE:**  
 IF RAILS HAVE BEEN PREVIOUSLY INSTALLED, LOOSEN TOPPER RAIL BRACKET RAIL SLIDES  
 AND ADJUST TO MEET DESIRED POSITIONING

**INSTALLATION IS COMPLETE!! MAKE SURE ALL FASTENERS ARE TIGHTENED**



## 2-Crossbar Kit, 58", White, Minivan



PRODUCT WEIGHT  
**16.1 LBS**

CROSSBOW LENGTH X  
HEIGHT

**59" x 2"**

CAPACITY

**REFER TO OEM'S  
RECOMMENDED LOAD  
RATING**

COLOR

**WHITE**

CATALOG NUMBER

**2BARCW**

### PRODUCT FEATURES

Aluminum base 2-crossbow kit for PROFILE™ HD Utility, grip lock, drop down, or combo ladder racks. Works with all compact van platforms for each respective wheelbase and Ford Transit Ship Thru. Works with and without OEM specific rail kit and generic mounting bracket kits.

Optional uprights and conduit kits available.

Please refer to OEM specific mounting kit or rail kit for additional information on compatible accessories.

# INSTALLATION GUIDE FOR PROFILE™ SERIES LADDER RACKS

INSTRUCTION #:  
**68895**

REV:  
**C**



THIS INSTRUCTION PROVIDES A GENERAL GUIDE OF INSTALLATION SEQUENCE FOR ALL PROFILE™ SERIES LADDER RACKS. PLEASE ENSURE ALL ACCESSORIES ARE INSTALLED PER TYPE OF RACK BEFORE PROCEEDING TO NEXT PAGE.

REFERENCE THIS INSTRUCTION THROUGHOUT THE ENTIRETY OF YOUR INSTALL TO PREVENT ACCESSORIES BEING INSTALLED INCORRECTLY/OUT OF SEQUENCE!

*STEPS 2T - 8T ON PAGE 3 IS THE RECOMMENDED ASSEMBLY SEQUENCE FOR A FULL TABLE ASSEMBLY BEFORE INSTALLING ON THE ROOF OF THE VEHICLE.*

*STEPS 2R - 8R ON PAGE 4 IS AN ALTERNATE ASSEMBLY SEQUENCE TO INSTALL THE RACK ON THE VEHICLE ROOF AS IT IS BUILT.*

PLEASE SELECT THE ASSEMBLY SEQUENCE THAT BEST WORKS FOR YOU!

## ASSEMBLY STEPS:

**STEP 1A.** *SUB-ASSEMBLE EACH CROSSBOW WITH DESIRED ACCESSORIES FOR SECTIONS A.1 & A.2.*

*INSTRUCTIONS FOR EACH KIT CAN BE FOUND IN THEIR RESPECTIVE CARTON!*

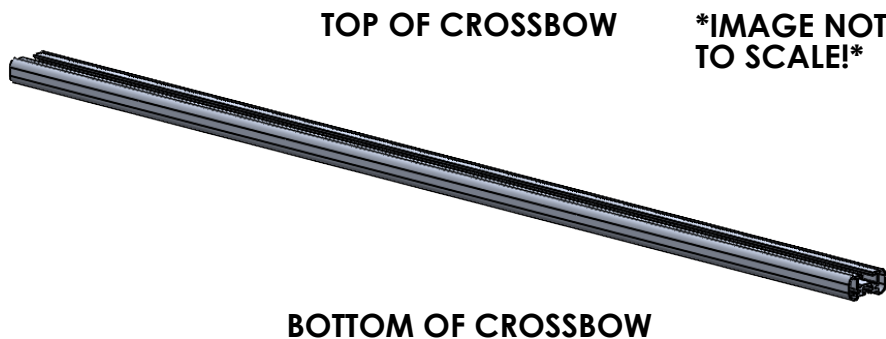

## TABLE 1

### TOP OF CROSSBOW

#### COMPONENTS TO INSTALL

A.1	HD UTILITY	- CONDUIT KIT OR BEACON
	Grip-Lock	- CONDUIT KIT OR BEACON
	ProLift	- CONDUIT KIT OR BEACON

### BOTTOM OF CROSSBOW

#### COMPONENTS TO INSTALL

A.2	HD UTILITY	- LADDER STOP, STROBE BRACKET, AND/OR REAR ROLLER
	Grip-Lock	- Grip-Lock SUB-ASSEMBLY
	ProLift	- DAMPER BRACKET

**STEP 1B. SUB-ASSEMBLE EACH CROSSBOW WITH DESIRED ACCESSORIES FOR SECTIONS B.1 & B.2. INSTRUCTIONS FOR EACH KIT CAN BE FOUND IN THEIR RESPECTIVE CARTON!**

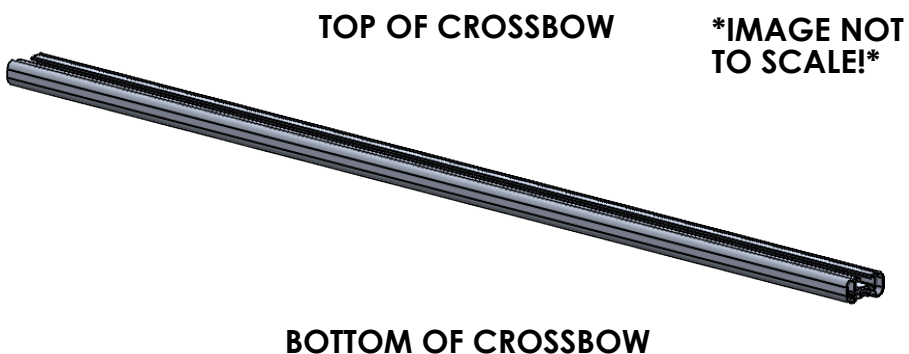

**ALTER WEAR STRIP AND INSTALL ON CROSSBOW (IF APPLICABLE)! REFERENCE TABLE 3 BELOW FOR WEAR STRIP ALTERATION INSTRUCTIONS!**

**TABLE 3**

ADDED ACCESSORIES	ALTERATION FOR WEAR STRIP
4" UPRIGHT***	REMOVE 2" FROM END OF WEAR STRIP
4" PVC CONDUIT KIT	REMOVE 7.25" FROM CENTER OF WEAR STRIP
6" PVC CONDUIT KIT	REMOVE 9.50" FROM CENTER OF WEAR STRIP
ALUMINUM BOX CONDUIT KIT	REMOVE 13.25" FROM CENTER OF WEAR STRIP
BEACON	REMOVE 4" FROM CENTER OF WEAR STRIP
ProLift (SINGLE SIDE)	CUT WEAR STRIP IN HALF, DO NOT INSTALL ON ProLift SIDE
ProLift (DUAL SIDE)	DO NOT INSTALL WEAR STRIP

**TABLE 2**

TOP OF CROSSBOW		
COMPONENTS TO INSTALL		
<b>B.1</b>	HD UTILITY	- WEAR STRIP (MODIFY IF NECESSARY, TABLE 3)
	Grip-Lock	- WEAR STRIP (MODIFY IF NECESSARY, TABLE 3)
	ProLift	- INNER STOP POST
BOTTOM OF CROSSBOW		
COMPONENTS TO INSTALL		
<b>B.2</b>	HD UTILITY	- MOUNTING BRACKETS
	Grip-Lock	- MOUNTING BRACKETS
	ProLift	- MOUNTING BRACKETS

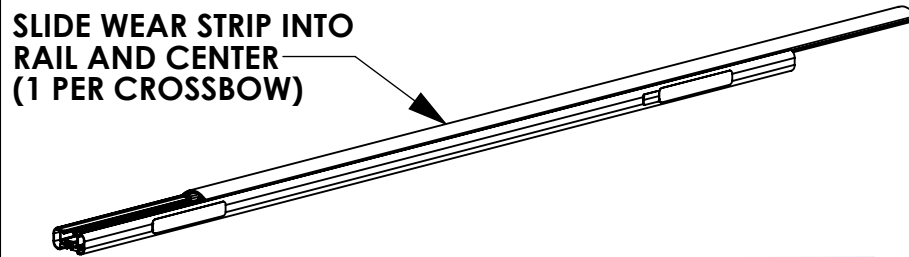

**SLIDE ONE SIDE OF WEAR STRIP INTO CROSSBOW, THEN ROLL OTHER SIDE TO SNAP STRIP INTO PLACE**

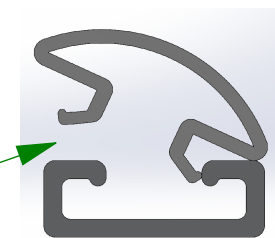

**STEP 1C SUB-ASSEMBLE EACH CROSSBOW WITH DESIRED ACCESSORIES FOR SECTIONS C.1 & C.2**

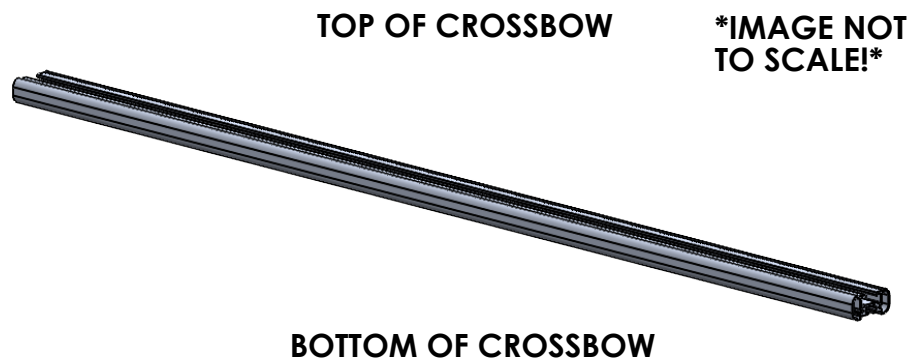

**TABLE 4**

TOP OF CROSSBOW		
COMPONENTS TO INSTALL		
C.1	HD UTILITY	- 4" UPRIGHT
	Grip-Lock	- N/A
	ProLift	- SLIDES FOR BASE EXTRUSION
BOTTOM OF CROSSBOW		
COMPONENTS TO INSTALL		
C.2	HD UTILITY	- UPRIGHTS (6", 9", RATCHET)
	Grip-Lock	- STROBES
	ProLift	- STROBES

**ASSEMBLY STEPS (FULL BENCH ASSEMBLY):**

- 2T. ADD DRIVELINES (IF INSTALLING ProLift)
- 3T. ADD HANDLES (IF INSTALLING Grip-Lock OR ProLift) AND DAMPERS (IF INSTALLING ProLift)
- 4T. ADD OUTER SUPPORT BARS (IF INSTALLING Grip-Lock OR ProLift)
- 5T. ADD STEP LADDER KIT (Grip-Lock OR ProLift ONLY!)

**6T. ASSEMBLE ENDS CAPS TO CROSSBOW**

USED FOR HD UTILITY & Grip-Lock RACKS

LOCATED IN CROSSBOW KIT

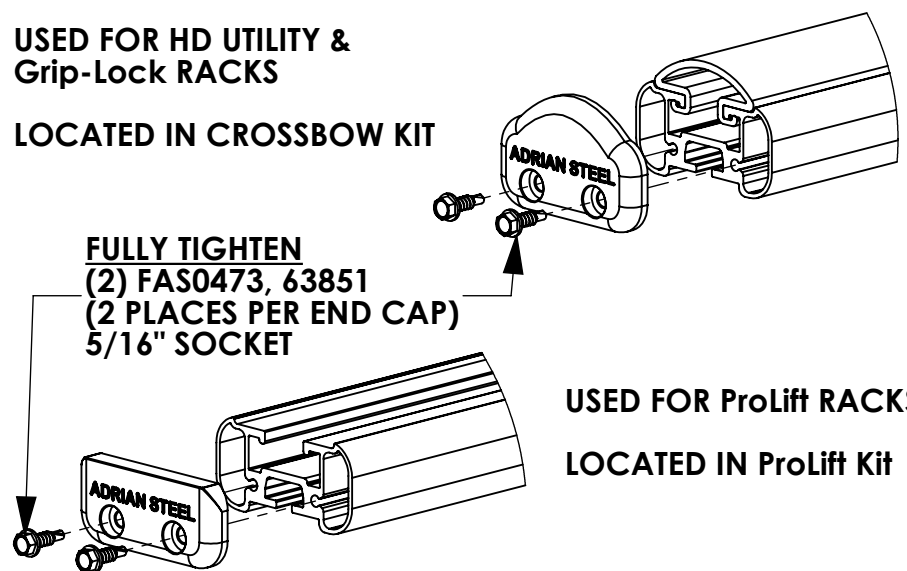

USED FOR ProLift RACKS  
LOCATED IN ProLift Kit

**7T. INSTALL ROOF RAIL KIT ON VEHICLE ROOF OR BOTTOM MOUNTING BRACKETS**

(ROOF RAIL KIT REQUIRED FOR Grip-Lock & ProLift OPTIONAL FOR HD UTILITY, NOT NEEDED FOR GM LADDER RACKS)

**8T. MOUNT CROSSBOW SUB-ASSEMBLIES FROM STEP 1 TO VEHICLE/MOUNTING BRACKET, OR ROOF RAIL (LOOSE INSTALL)**

**ALTERNATE ASSEMBLY METHOD!**  
**(ASSEMBLE ON VEHICLE ROOF):**

2R. INSTALL ROOF RAIL KIT ON VEHICLE ROOF OR BOTTOM MOUNTING BRACKETS

(ROOF RAIL KIT REQUIRED FOR Grip-Lock & ProLift, OPTIONAL FOR HD UTILITY, NOT NEEDED FOR GM LADDER RACKS)

3R. MOUNT CROSSBOW SUB-ASSEMBLIES FROM STEP 1 TO VEHICLE/MOUNTING BRACKET, OR ROOF RAIL (LOOSE INSTALL)

4R. ADD DRIVELINES (IF INSTALLING ProLift)

5R. ADD HANDLES (IF INSTALLING Grip-Lock OR ProLift) AND DAMPERS (IF INSTALLING ProLift)

6R. ADD OUTER SUPPORT BARS (IF INSTALLING Grip-Lock OR ProLift)

7R. ADD STEP LADDER KIT (Grip-Lock OR ProLift ONLY!)

8R. ASSEMBLE END CAPS TO CROSSBOW

USED FOR HD UTILITY &  
Grip-Lock RACKS

LOCATED IN CROSSBOW KIT

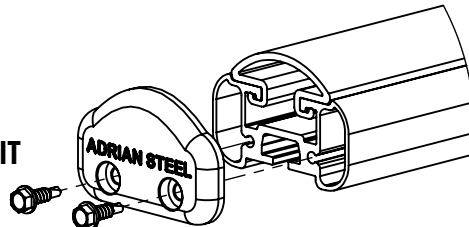

**FULLY TIGHTEN**  
**(2) FAS0473, 63851**  
**(2 PLACES PER END CAP)**  
**5/16" SOCKET**

USED FOR ProLift RACKS  
LOCATED IN ProLift Kit

