

INSTR. : 69485  
NUMBER

PG: 1  
REV: A

PART .Max Drop ProLift  
NUMBER •High Roof

PART •ProLift Adjustment Instructions -  
DESC. •High Roof Vans

Step 3: With 1/2" Socket loosen nut, slide post so that it is snug against ladder. Tighten nut

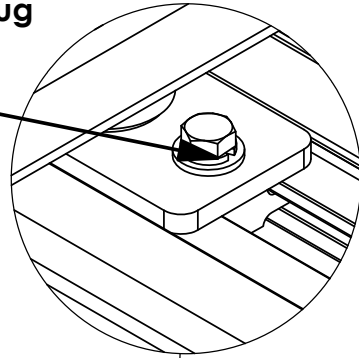

Step 1: Make sure clamp is roughly 1/8" from end of secondary drop  
If not loosen nuts (X2) with 1/2" socket and slide so it is within 1/8".  
Tighten Nuts (X2)

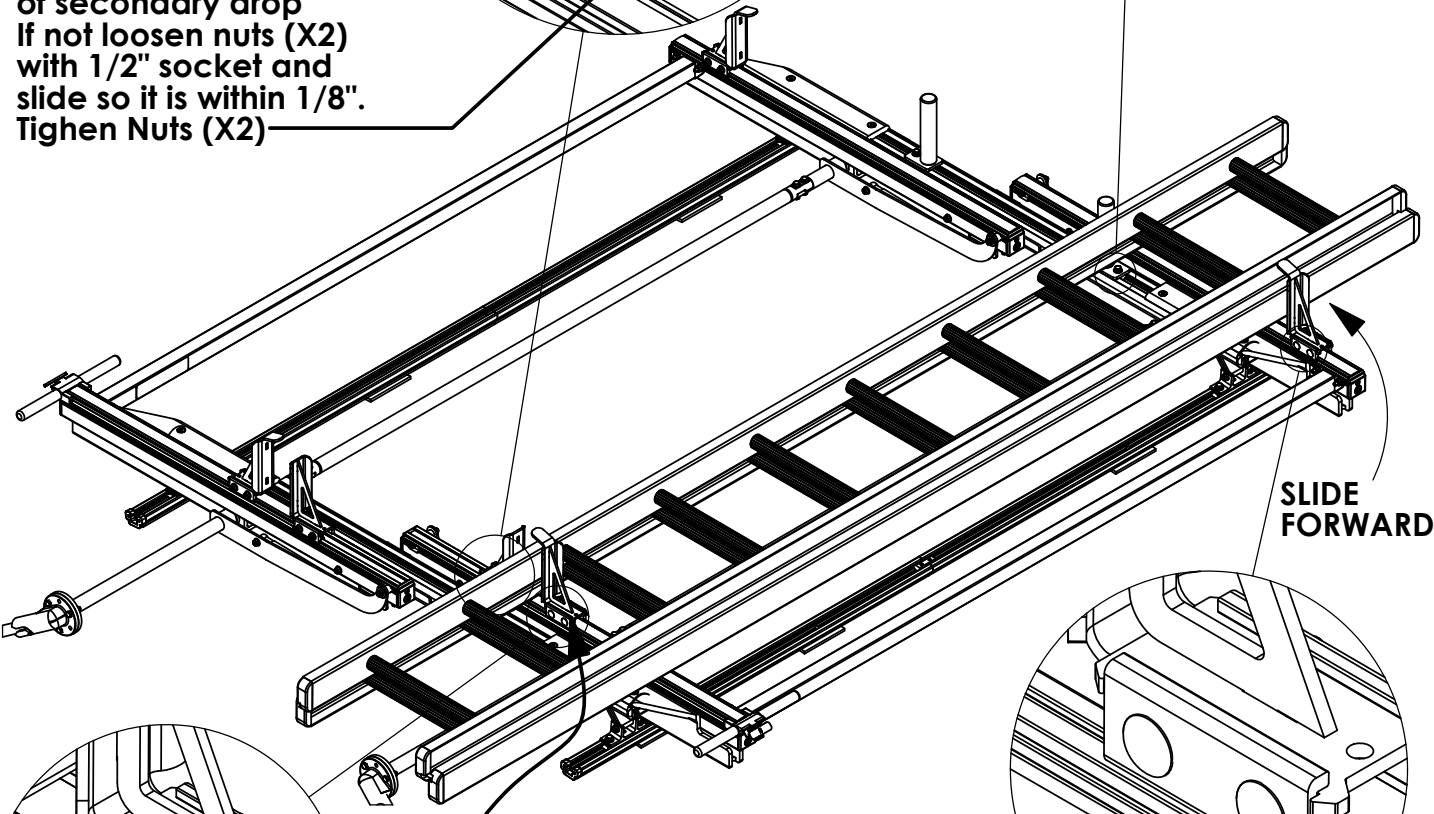
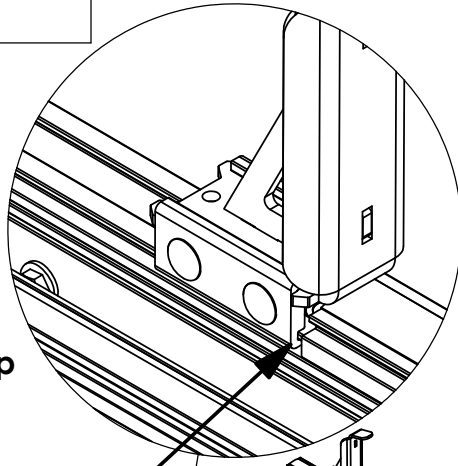

SLIDE FORWARD

SLIDE FORWARD

Step 4: With 1/2" Socket loosen nuts (X2), slide clamp so that it is snug against ladder. Tighten nuts (X2).

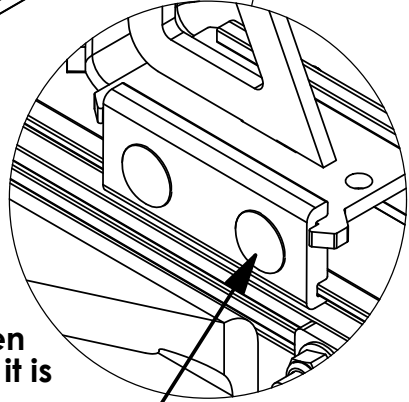

Step 2: With 1/2" Socket loosen nuts (X2), slide clamp so that it is snug against ladder. Tighten nuts (X2).

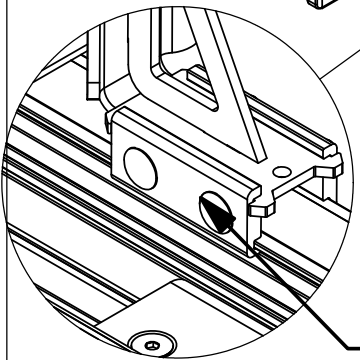

Once all brackets are adjusted operate rack to make sure clamps are not too tight

INSTR. NUMBER : <b>68627</b>	PG: <b>1</b>	REV: <b>B</b>	ITEM NO.	PART NUMBER	DESCRIPTION	QTY.
	PART NUMBER : <b>PLMDPSH</b> PART NUMBER : <b>PLMDDSH</b>		1	68400-W	PROLIFT,HR,DROP ASM,PS,RR, WHITE	1
2			68399-W	PROLIFT,HR,DROP ASM,PS,FR, WHITE	1	
PART • PROLIFT,MAX,PS,HR DESC. • PROLIFT,MAX,DS,HR		3	66959-W	DROP DOWN OUTER BAR, WELDMENT, WHITE	1	
		4	66572-B	DROP DOWN, CS CENTER DRIVELINE, BLK	1	
		5	48265	DAMPER ASSEMBLY	1	
		6	58239	COMPRESSION DAMPER	1	
		7	56330	HANDLE ASM, DDLR, HR	1	
		8	68037-B	CLAMP PAD, 6.5", BLACK	2	
		9	68458-B	PROLIFT,HR,INNER CLAMP,B	1	
		10	68186-W	PROLIFT INNER POST, WHITE	1	
		11	68628-W	PROLIFT,HR,DAMPER BRKT, W	2	

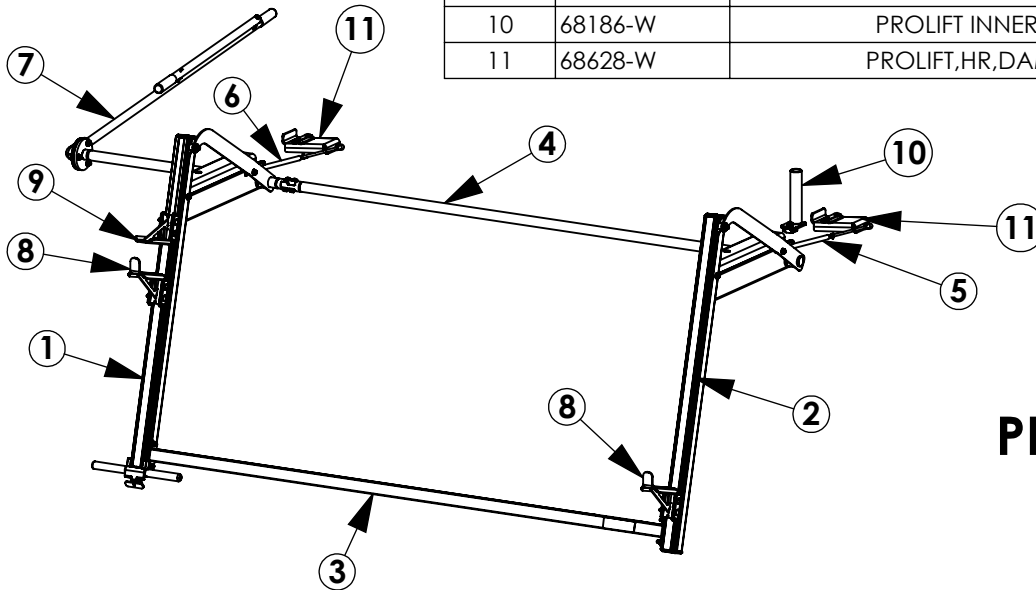

**PLMDPSHW**

ITEM NO.	PART NUMBER	DESCRIPTION	QTY.
1	68402-W	PROLIFT,HR,DROP ASM,DS,RR, WHITE	1
2	68401-W	PROLIFT,HR,DROP ASM,DS,FR, WHITE	1
3	66959-W	DROP DOWN OUTER BAR, WELDMENT, WHITE	1
4	66563-B	DROP DOWN, SS CENTER DRIVELINE, BLK	1
5	48265	DAMPER ASSEMBLY	1
6	58239	COMPRESSION DAMPER	1
7	56330	HANDLE ASM, DDLR, HR	1
8	68037-B	CLAMP PAD, 6.5", BLACK	2
9	68458-B	PROLIFT,HR,INNER CLAMP,B	1
10	68186-W	PROLIFT INNER POST, WHITE	1
11	68628-W	PROLIFT,HR,DAMPER BRKT, W	2

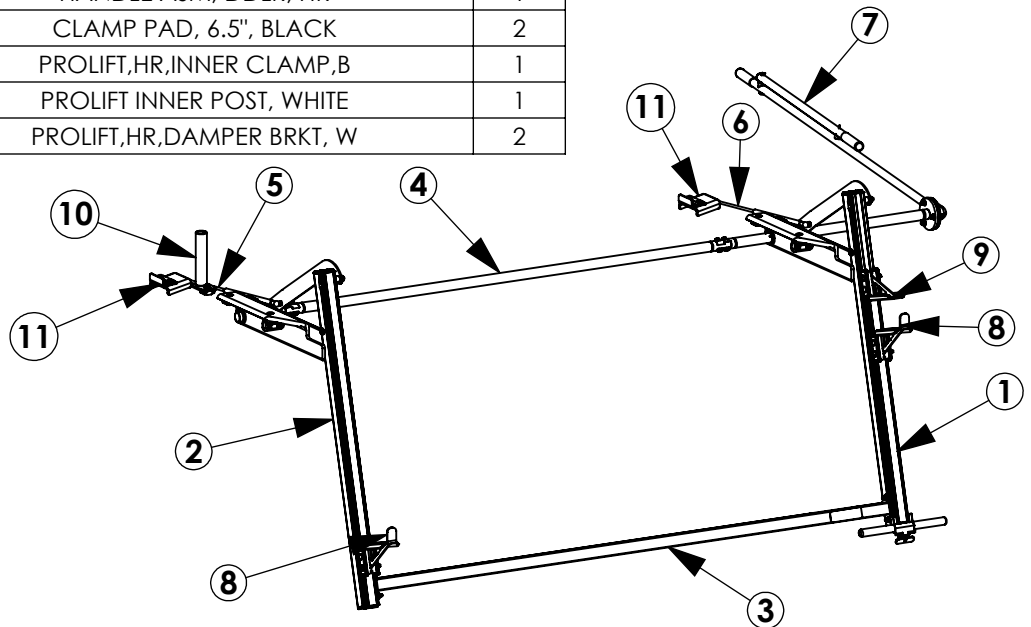

**PLMDDSHW**

**GET TO KNOW THE VEHICLE** - AT THE BEGINNING OF ANY INSTALLATION, CHECK THE LOCATION OF THE FUEL TANK, FUEL LINES, BRAKE LINES, HIGH VOLTAGE BATTERIES AND WIRING HARNESSSES TO AVOID INJURY OR PROPERTY DAMAGE FROM TOOL CONTACT.

**SEAL ALL EXTERIOR HOLES** - ALL INSTALLATION HOLES SHOULD BE SEALED WITH BUTYL TAPE OR SILICON TO PREVENT WATER AND EXHAUST GASES FROM ENTERING THE VEHICLE.

**CONTROL DRILL DEPTH** - TO AVOID DAMAGE TO THE VEHICLE, USE A DRILL STOP OR CLEARED STEP BIT WHEN DRILLING INSTALLATION HOLES.

**ALWAYS ADD PRIMER** - WHEN ADDING INSTALLATION HOLES BE SURE TO USE A SELF-ETCHING PRIMER TO PREVENT CORROSION, FASTENER FAILURE AND INJURY.

**MOUNTING POINTS MUST HAVE METAL-TO-METAL CONTACT** - USE PROVIDED MOUNTING SPACERS TO ACCOMMODATE FOR VEHICLE FEATURES, CARPET OR SUBFLOORS.

**PROVIDE CLEARANCE FOR SPACERS** - IF THE INSTALLATION VEHICLE CONTAINS A CARPET OR SUBFLOOR, USE A 1-3/16" DIAMETER CARPET CUTTER (P/N: 31183-0) AT ALL MOUNTING LOCATIONS TO OPEN UP ROOM FOR SPACERS.

**CHECK SPACER ORIENTATION** - BE SURE THAT THE INDENT IN THE SPACER COVERS THE PLUSNUT HEAD; THIS ENSURES THE MOST METAL-TO-METAL CONTACT AND REDUCES VIBRATION.

**PLUSNUT INSTALLATION** - A PLUSNUT GUN IS RECOMMENDED FOR PLUSNUT INSTALLATION FOR ITS PRODUCTION SPEED. HOWEVER, A PLUSNUT SETTING TOOL CAN ALSO BE USED (P/N: 22200-0).

**THRU-BOLT CLEARANCE** - WHEN USING A THRU-BOLT AT ANY MOUNTING LOCATION, BE SURE THAT YOUR HOLE HAS 1/16" CLEARANCE.

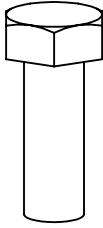
**FASTENERS USED**

**FAS0283**  
SCREW, HH  
5/16-18X.875  
QTY: 1

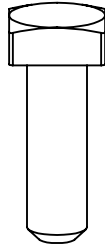

**FAS0035**  
BOLT, SQ HD  
5/16-18X1.0  
QTY: 4

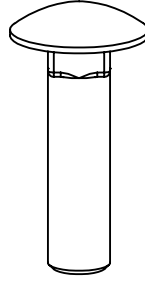

**FAS0812**  
BOLT, CRG  
5/16-18X1.25  
QTY: 4

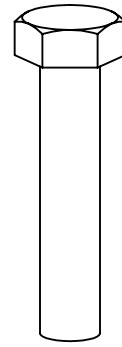

**FAS0242**  
SCREW, HH  
5/16-18X1.5  
QTY: 4

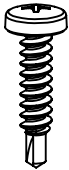

**FAS0782**  
SCREW, THP TEK  
#8X.75  
QTY: 3



**FAS0473**  
SCREW, HH TEK  
#12X.75  
QTY: 4

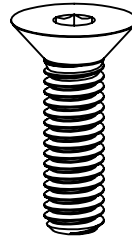

**FAS0856**  
SCREW, FHH  
5/16-18X1.125  
QTY: 4

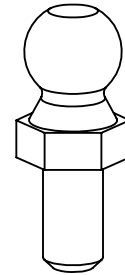

**34927-0**  
SCREW, FHH  
5/16-18X1.125  
QTY: 2



**FAS0552**  
WASHER, FLAT  
USS 5/16  
QTY: 5



**FAS0588**  
WASHER, LCK  
SPLIT 5/16  
QTY: 1



**FAS0857**  
WASHER, LCK EXT  
CS 5/16  
QTY: 4

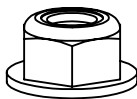

**FAS0861**  
NUT, HEX NLK  
FLG 5/16-18  
QTY: 20

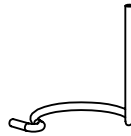

**34928-0**  
CLIP, SPRING,  
RETAINER 13MM  
QTY: 4

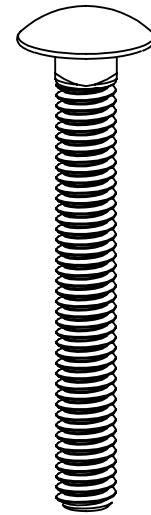

**FAS0838**  
BOLT, CRG  
5/16-18X2.5  
QTY: 6

**HARDWARE USED**

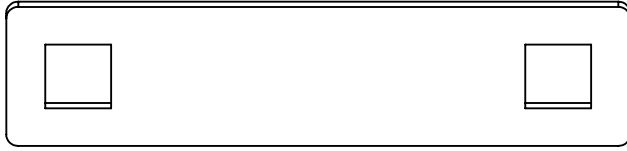

**64830  
REAR ROLLER,  
BOLT PLATE  
QTY: 2**

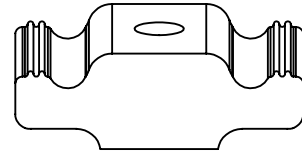

**63490  
RAIL SLIDE,  
1"  
QTY: 5**

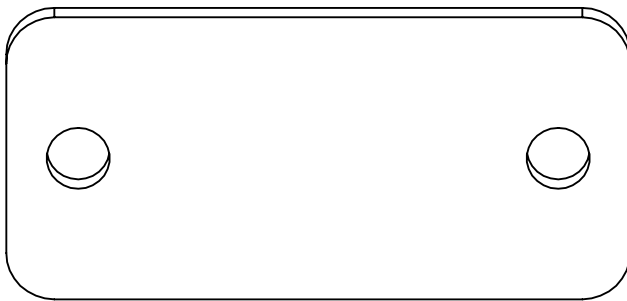

**64831  
REAR ROLLER,  
SPACER  
QTY: 2**

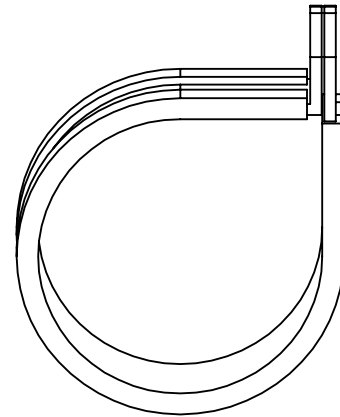

**34921-0  
CLAMP, CABLE  
1-1/2"  
QTY: 1**

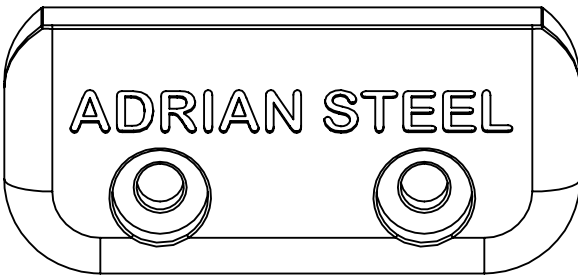

**65961  
DROP DOWN  
END CAP  
QTY: 2**

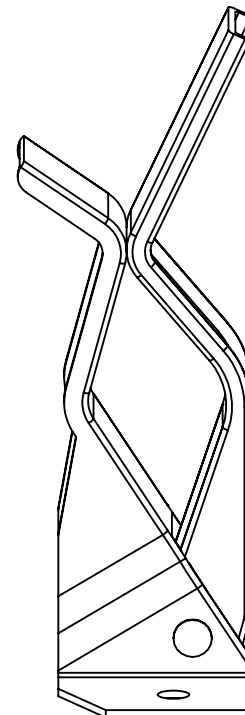

**34922-0  
HOLDER, TOOL  
QTY: 1**

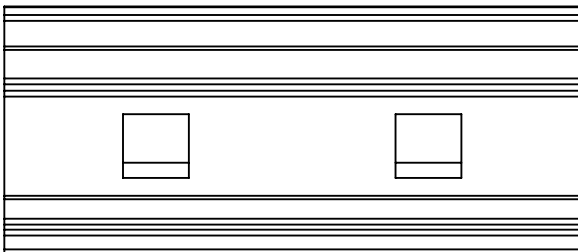

**65963-W  
STOP CLAMP  
QTY: 6**

**BEGIN ASSEMBLY**

**STEP 1 - INSTALL CLAMPS AND HARDWARE ON DROP DOWN CARTRIDGES**

**PASSENGER SIDE CARTRIDGES**

**REAR SUB-ASSEMBLY**

**FRONT SUB-ASSEMBLY**

LOOSELY INSTALL  
FAS0856, FAS0857,  
& 63490  
(4 PLACES)

LOCATION IS APPROXIMATE  
AND WILL BE ADJUSTED LATER

FAS0035  
SLIDE INTO SLOT  
(4 PLACES)

FAS0838, FAS0861  
(6 PLACES)  
1/2" SOCKET

NOTE ORIENTATION:  
SMALLER CHANNEL ON  
BOTTOM

**DRIVER SIDE CARTRIDGES**

**REAR SUB-ASSEMBLY**

LOCATION IS APPROXIMATE  
AND WILL BE ADJUSTED LATER

LOOSELY INSTALL  
FAS0856, FAS0857,  
& 63490  
(4 PLACES)

FAS0035  
SLIDE INTO SLOT  
(4 PLACES)

FAS0838, FAS0861  
(6 PLACES)  
1/2" SOCKET

**FRONT SUB-ASSEMBLY**

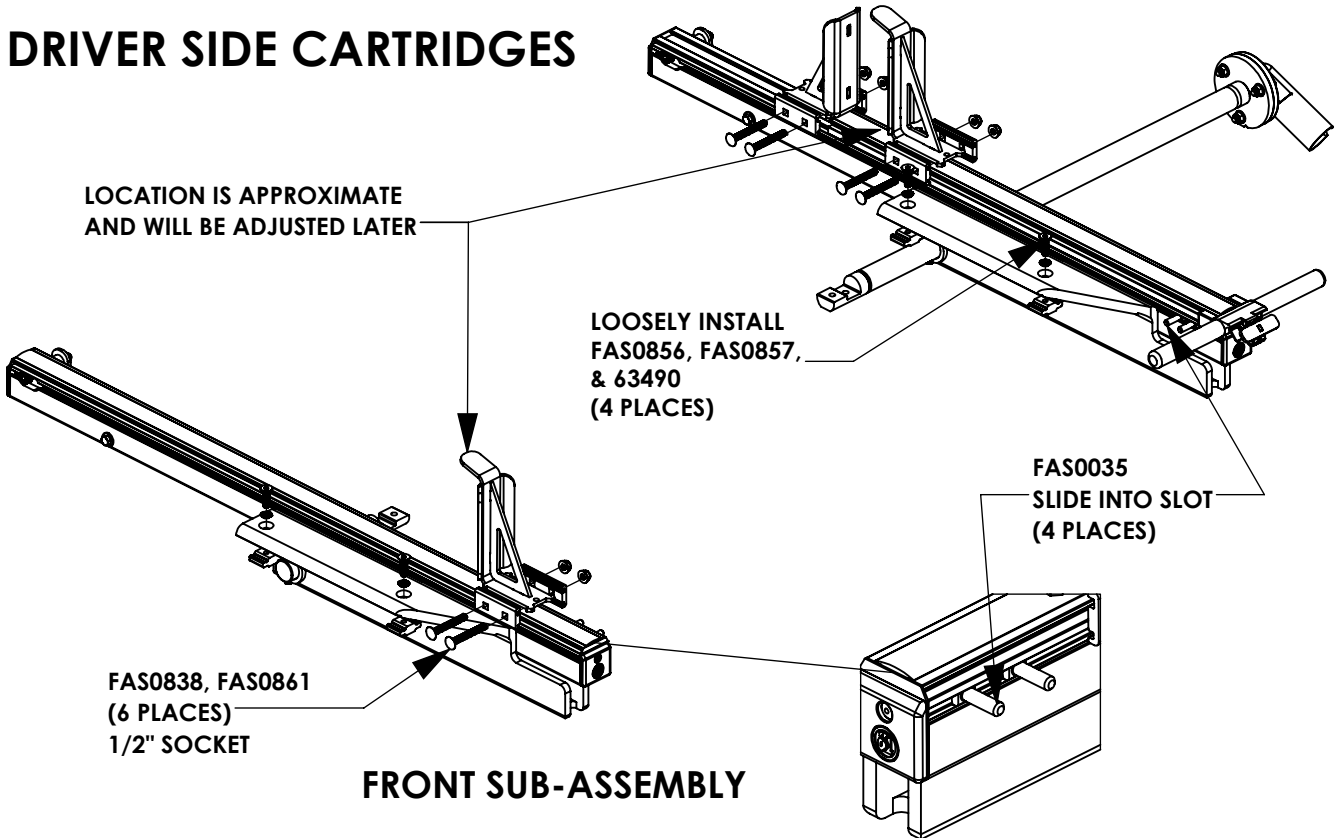
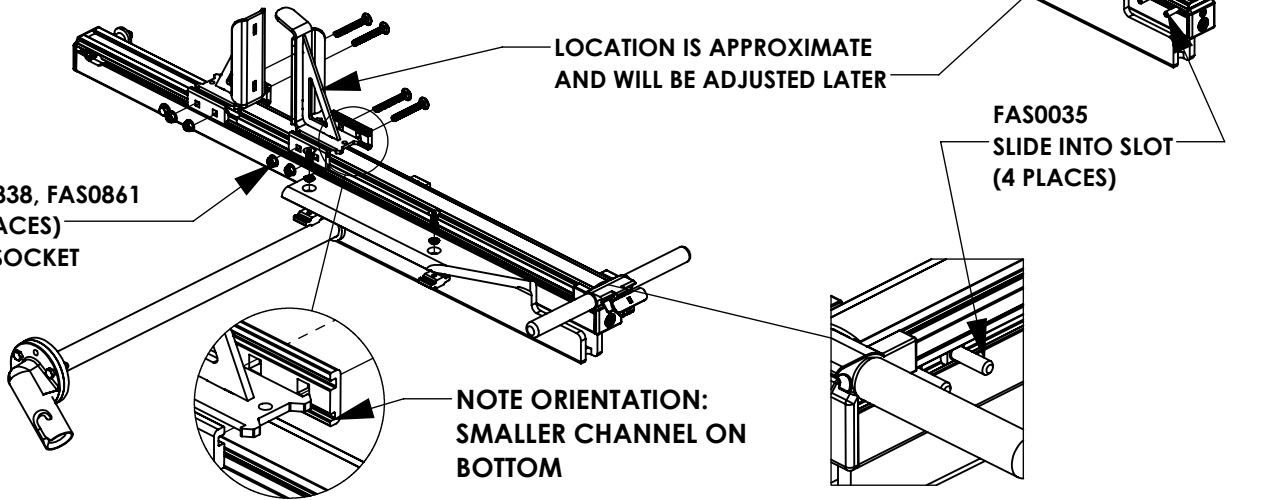

**STEP 2 - MOUNT DAMPER BRACKETS AND INNER STOPS TO CROSSBOWS**

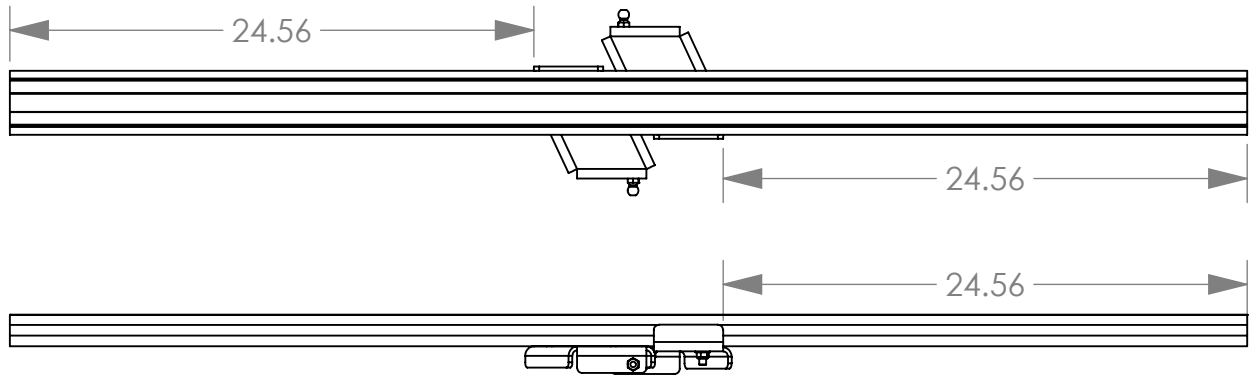
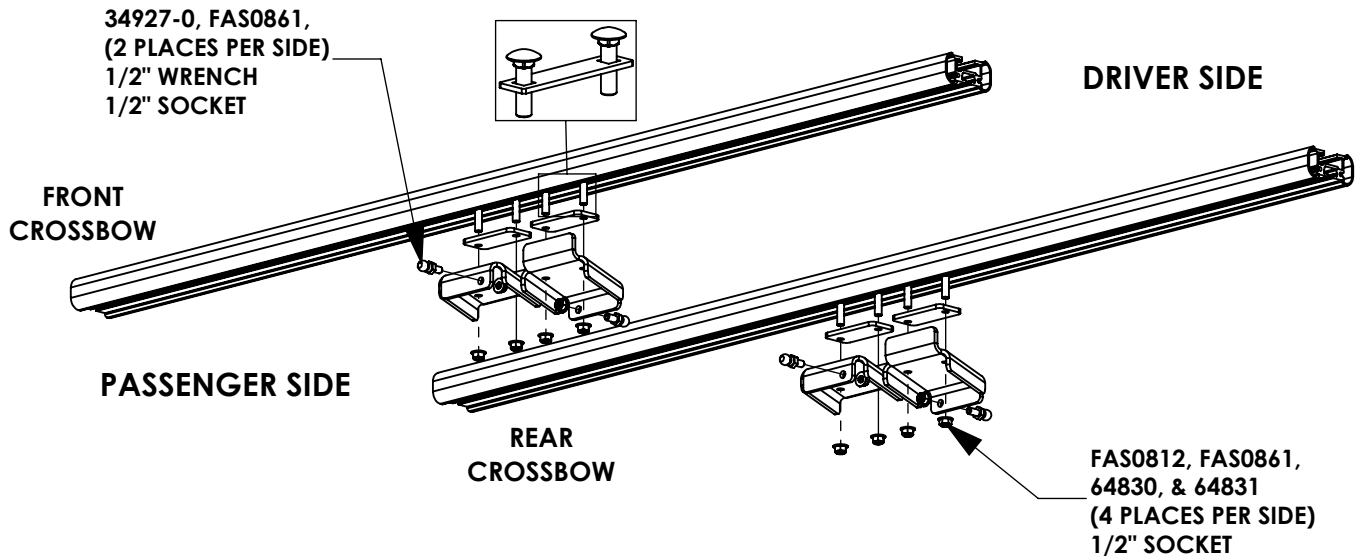

FAS0283, FAS0552,  
FAS0861  
(1 PLACE PER SIDE)  
1/2" SOCKET

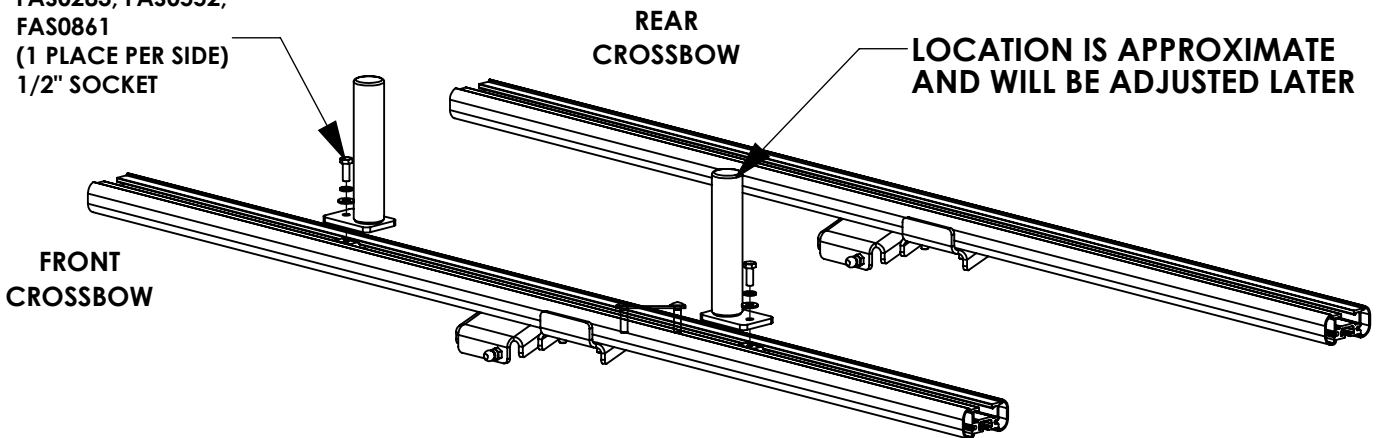

### STEP 3 - INSTALL CARTRIDGES ON CROSSBOWS

FULLY TIGHTEN  
FAS0856, FAS0857,  
& 63490  
(4 PLACES PER SIDE)  
3/16" ALLEN

PASSENGER SIDE

DRIVELINE WILL BE  
UNDER CROSSBOW

DRIVER SIDE

SLIDE CARTRIDGES  
ONTO CROSSBOWS

LINE UP CORNERS WITH  
END OF CROSSBOWS

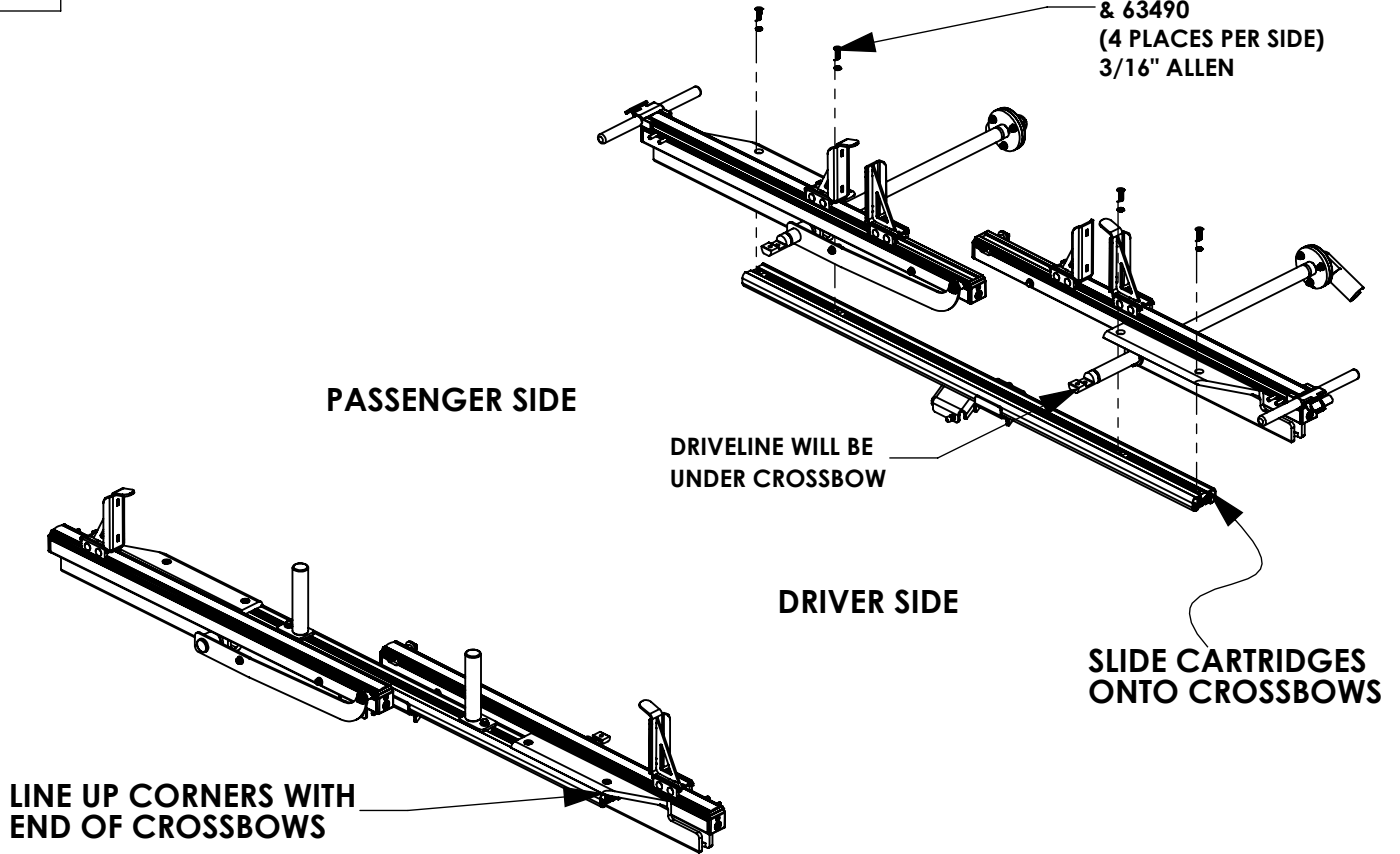

### STEP 4 - INSTALL DAMPERS

48265  
EXTENSION DAMPER

ATTACH DAMPERS  
TO BALL STUDS

INSERT 34928-0 LOCKING  
PINS AFTER MOUNTING  
TO BALL STUDS  
(4 PLACES PER SIDE)

58239  
COMPRESSION DAMPER

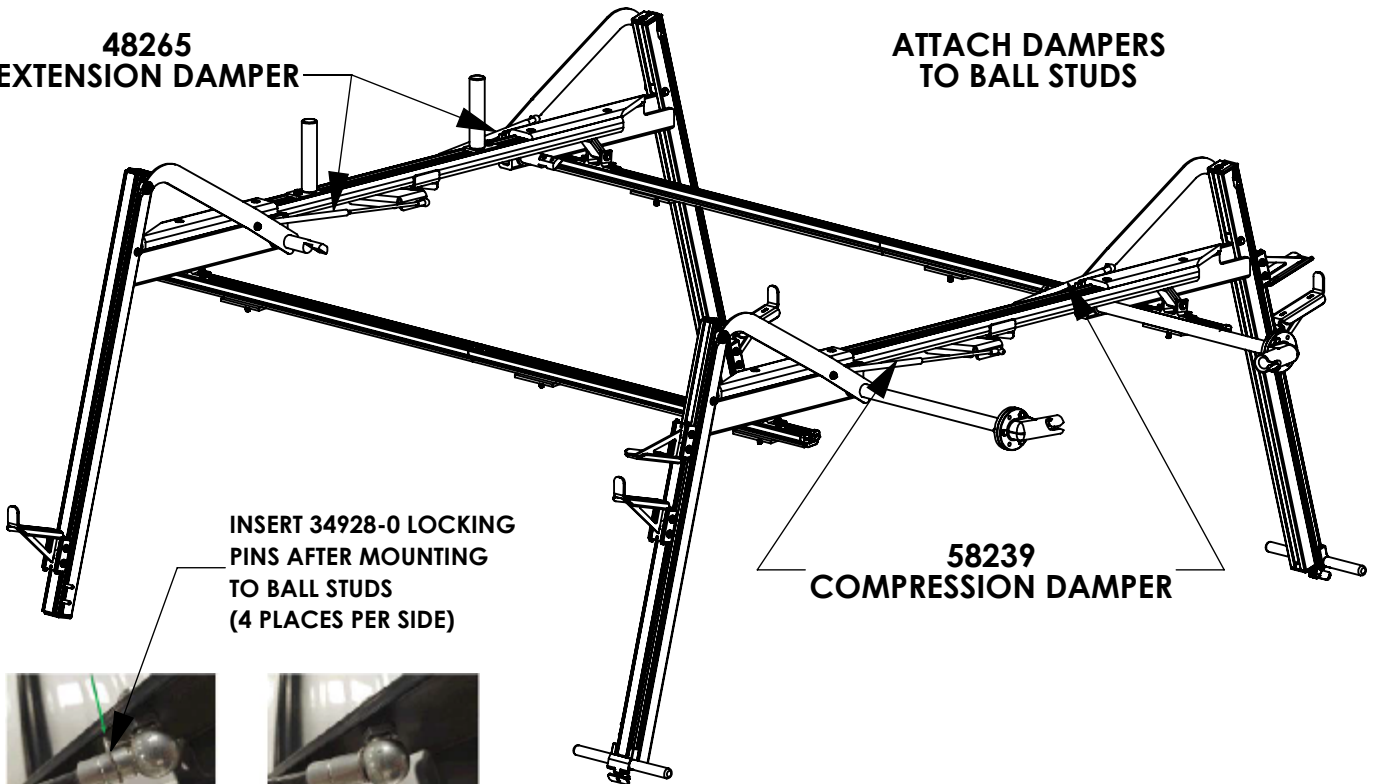

### STEP 5 - INSTALL DRIVELINE AND O.S. BAR

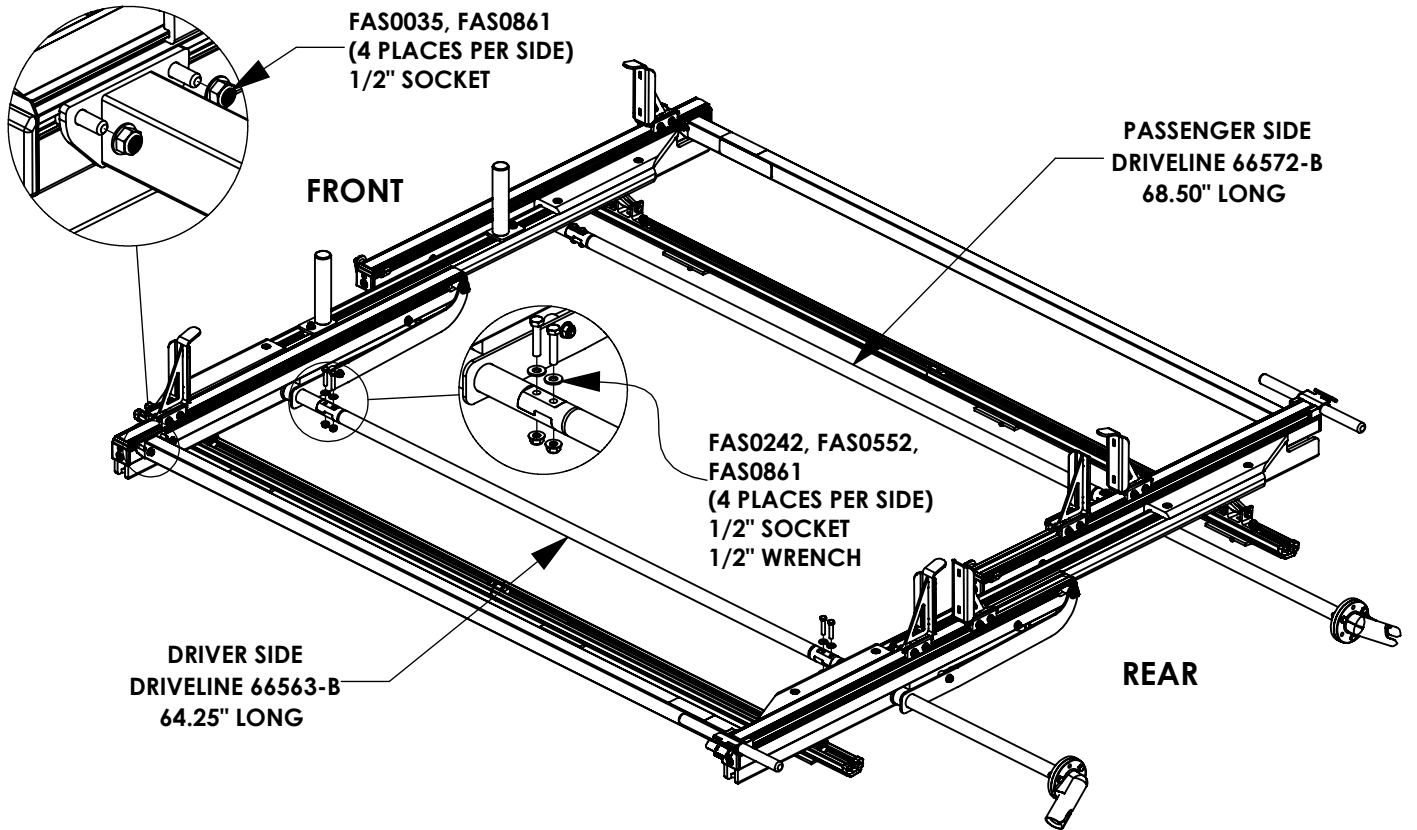

### STEP 6 - INSTALL CROSSBOW END CAPS

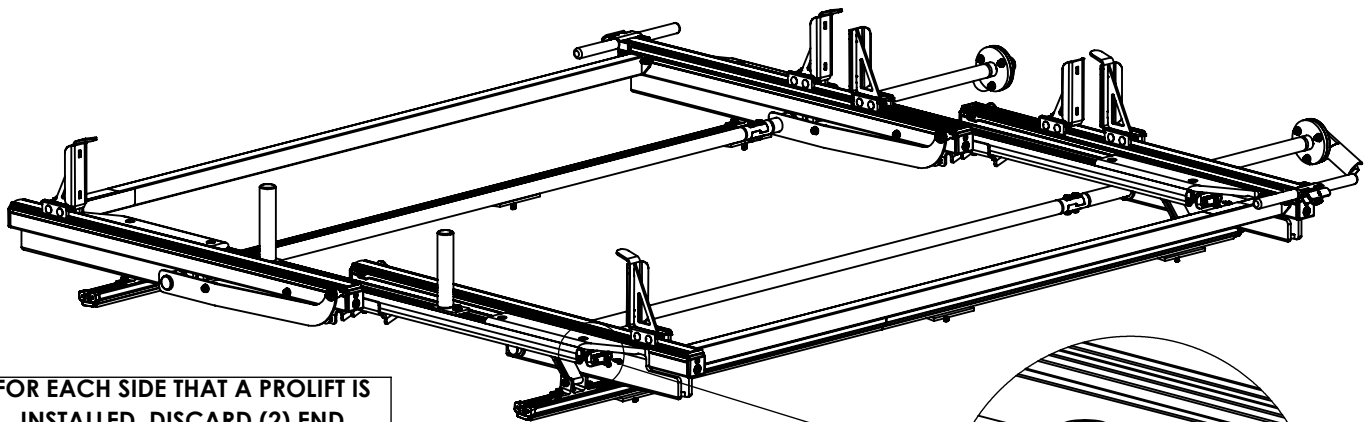

FOR EACH SIDE THAT A PROLIFT IS  
INSTALLED, DISCARD (2) END  
CAPS THAT ARE INCLUDED WITH  
THE CROSSBOW KIT.

SHOWN BELOW:



65961, (2) FAS0473  
(2 PLACES PER SIDE)  
5/16" SOCKET

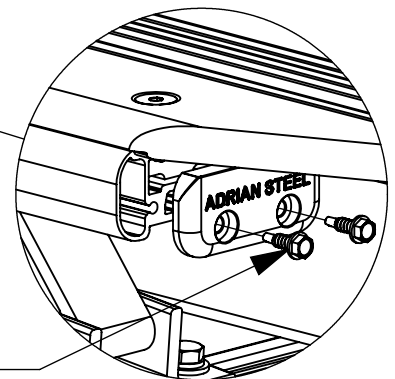

**STEP 7 - INSTALL HANDLE STORAGE HARDWARE**

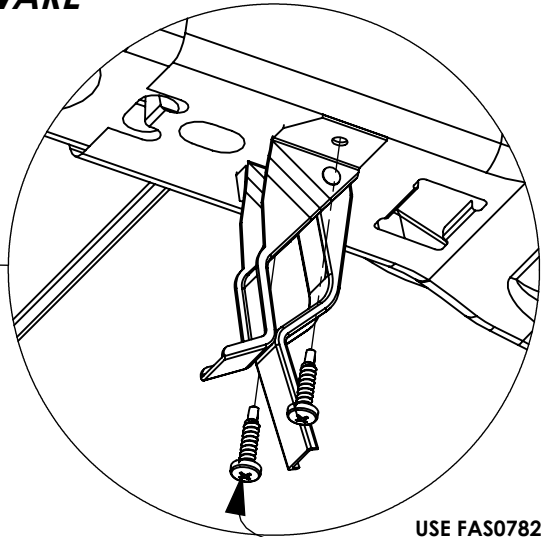
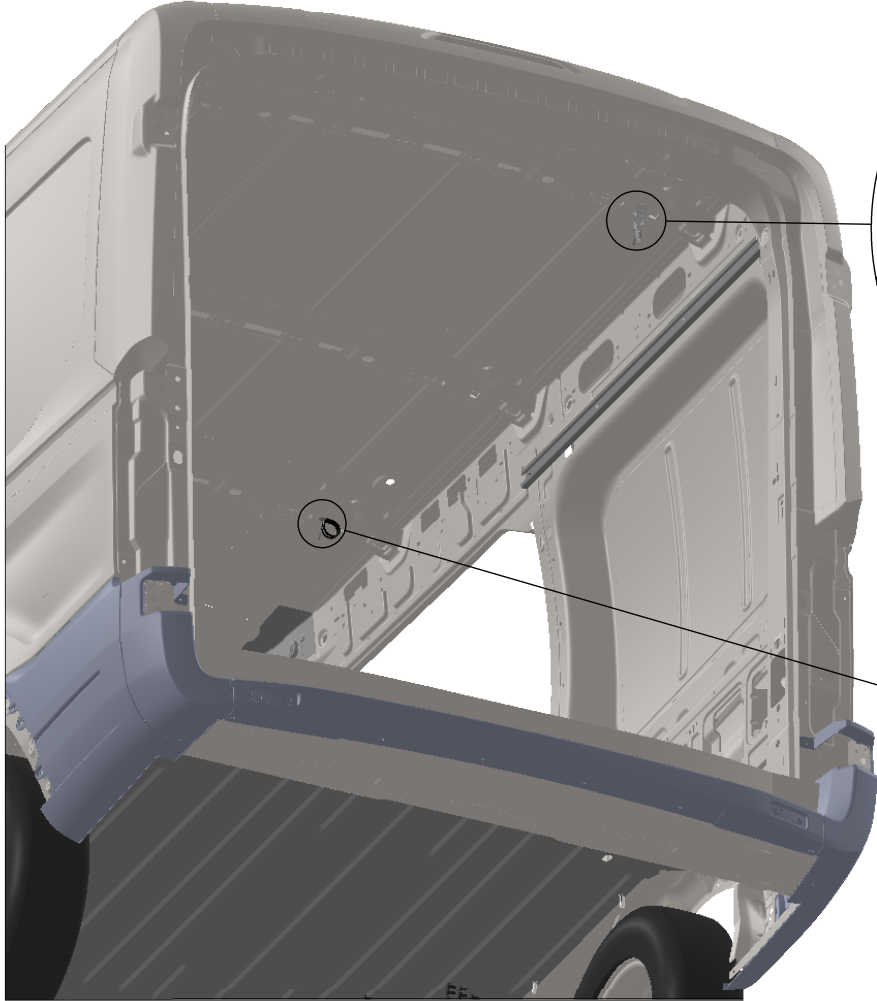

USE FAS0782  
(3 PLACES)  
#2 PHILLIPS

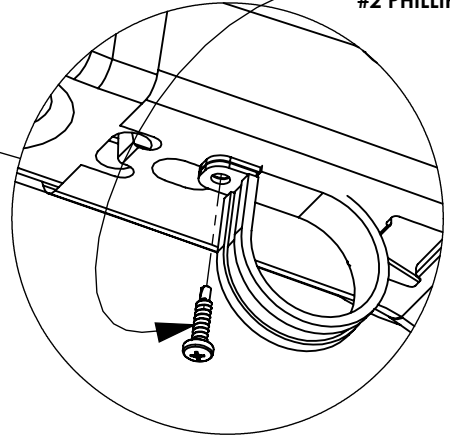

**STEP 8 - CLIP HANDLE INTO STORAGE CLIP**

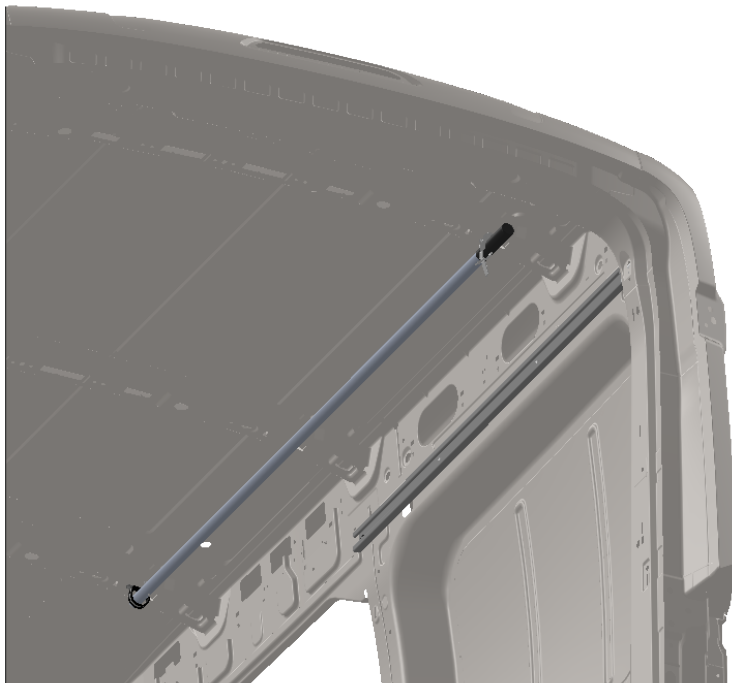

INSTR. NUMBER	PG:	REV:	ITEM NO.	PART NUMBER	DESCRIPTION	QTY.
<b>79299</b>	<b>1</b>	<b>A</b>	1	79222	FT LWB HR/MR RAIL 1	2
<b>RRKFT148MRHR</b>			2	52709	SPACER-PAD .25 TRANSIT LR LDRK	6
ROOF RAIL KIT FT FSV			3	79223	FT LWB HR/MR RAIL 2	2

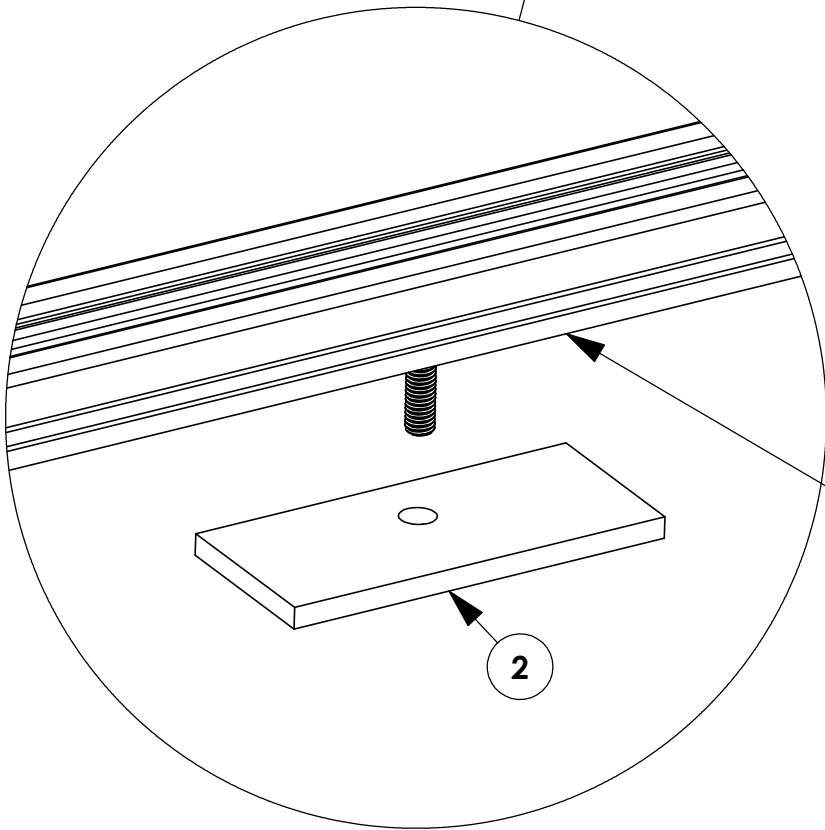
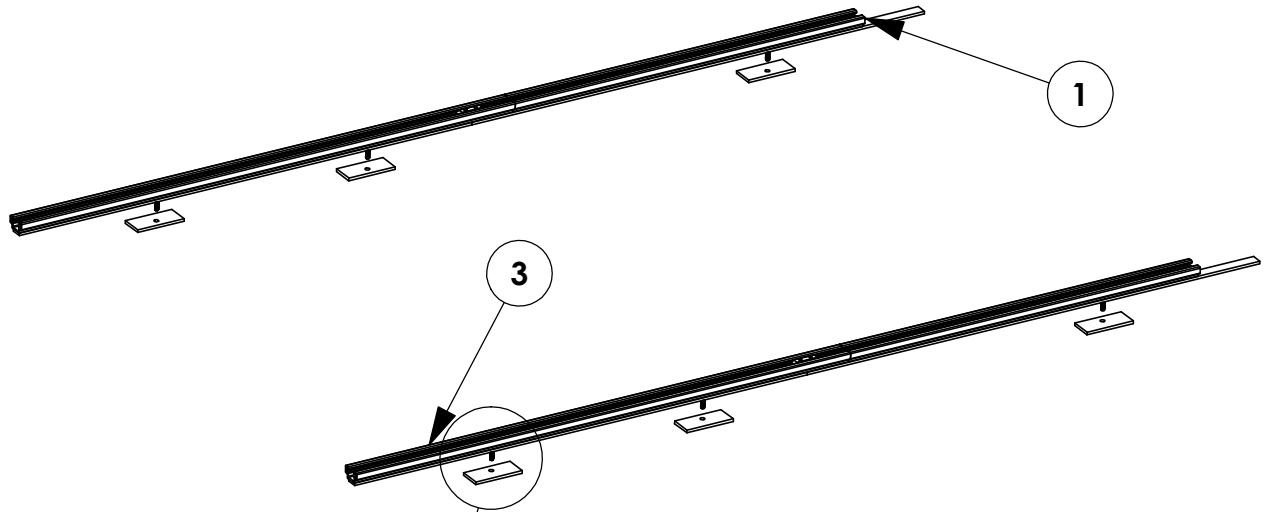

**ATTENTION!**

PLEASE VERIFY THAT FOAM TAPE HAS BEEN INCLUDED ON THE BOTTOM OF EACH RAIL.

DO NOT INSTALL RAILS IF THE FOAM TAPE IS MISSING!

**TOOLS NEEDED:**

- DRIVE RATCHET
- IMPACT DRIVER
- 13mm SOCKET
- 5/32" HEX DRIVE
- M8-1.25 TAP
- TAPE MEASURE

**GET TO KNOW THE VEHICLE** - AT THE BEGINNING OF ANY INSTALLATION, CHECK THE LOCATION OF THE FUEL TANK, FUEL LINES, BRAKE LINES, HIGH VOLTAGE BATTERIES AND WIRING HARNESSSES TO AVOID INJURY OR PROPERTY DAMAGE FROM TOOL CONTACT.

**SEAL ALL EXTERIOR HOLES** - ALL INSTALLATION HOLES SHOULD BE SEALED WITH BUTYL TAPE OR SILICON TO PREVENT WATER AND EXHAUST GASES FROM ENTERING THE VEHICLE.

**CONTROL DRILL DEPTH** - TO AVOID DAMAGE TO THE VEHICLE, USE A DRILL STOP OR CLEARED STEP BIT WHEN DRILLING INSTALLATION HOLES.

**ALWAYS ADD PRIMER** - WHEN ADDING INSTALLATION HOLES BE SURE TO USE A SELF-ETCHING PRIMER TO PREVENT CORROSION, FASTENER FAILURE AND INJURY.

**MOUNTING POINTS MUST HAVE METAL-TO-METAL CONTACT** - USE PROVIDED MOUNTING SPACERS TO ACCOMMODATE FOR VEHICLE FEATURES, CARPET OR SUBFLOORS.

**PROVIDE CLEARANCE FOR SPACERS** - IF THE INSTALLATION VEHICLE CONTAINS A CARPET OR SUBFLOOR, USE A 1-3/16" DIAMETER CARPET CUTTER (P/N: 31183-0) AT ALL MOUNTING LOCATIONS TO OPEN UP ROOM FOR SPACERS.

**CHECK SPACER ORIENTATION** - BE SURE THAT THE INDENT IN THE SPACER COVERS THE PLUSNUT HEAD; THIS ENSURES THE MOST METAL-TO-METAL CONTACT AND REDUCES VIBRATION.

**PLUSNUT INSTALLATION** - A PLUSNUT GUN IS RECOMMENDED FOR PLUSNUT INSTALLATION FOR ITS PRODUCTION SPEED. HOWEVER, A PLUSNUT SETTING TOOL CAN ALSO BE USED (P/N: 22200-0).

**THRU-BOLT CLEARANCE** - WHEN USING A THRU-BOLT AT ANY MOUNTING LOCATION, BE SURE THAT YOUR HOLE HAS 1/16" CLEARANCE.

**FASTENERS AND HARDWARE USED**

**BAG REFERENCE: BAGRRKFTM & BAG63411**

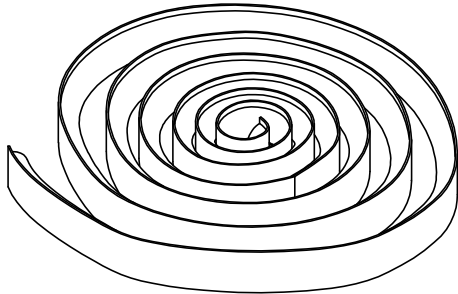

05586-0  
BUTYL TAPE  
1FT ROLL  
QTY: 1

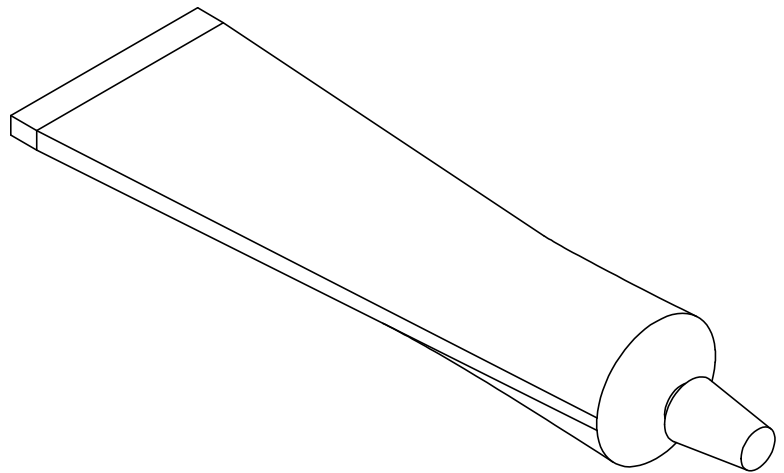

26618-0  
SILICONE  
1OZ TUBE  
QTY: 1

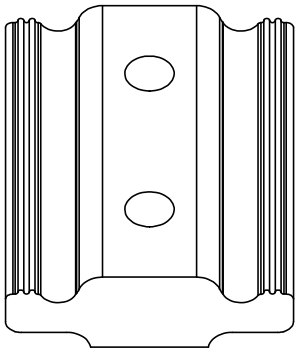

63491  
RAIL CONNECTOR, 2"  
QTY: 2

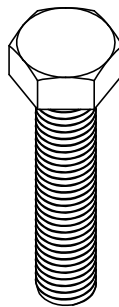

FAS0351  
SCREW, HH SS  
M8-1.25X40  
QTY: 6

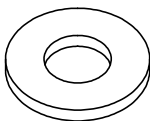

FAS0552  
WASHER, FLAT  
5/16 SS  
QTY: 6



FAS0497  
SCREW, SET  
5/16-18X.75 SS  
QTY: 4



FAS0588  
WASHER, LCK  
SPLIT 5/16 SS  
QTY: 6

**PAGE INTENTIONALLY LEFT BLANK**

**STEP 1 - ASSEMBLE ROOF RAILS**

**STEP 1.1**  
**FULLY TIGHTEN**  
**63491, (02) FAS0497**  
**(02 PLACES)**  
**5/32" HEX DRIVE**

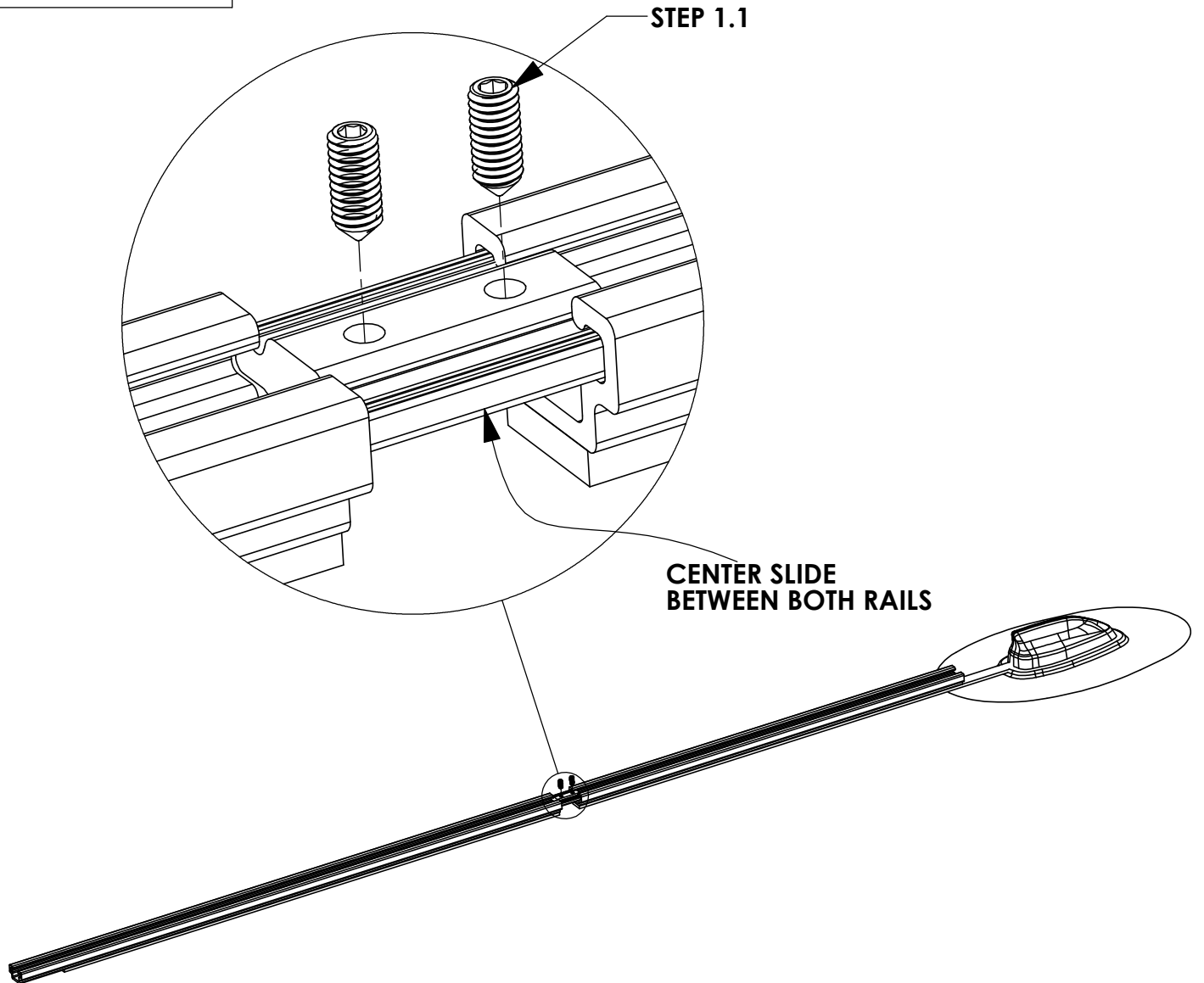

**STEP 2 - INSTALL ROOF RAILS ONTO VEHICLE ROOF**

**STEP 2.1  
REMOVE OEM  
PLASTIC PLUG**

USE M8-1.25 TAP  
TO CLEAR THREAD  
OF OEM WELD NUT  
(IF NECESSARY)

ROOF HOLE  
CLEARANCING  
MAY BE  
NECESSARY DO TO  
OEM ROOF  
TOLERANCE

**STEP 2.2  
FULLY TIGHTEN  
FAS0351, FAS0552,  
FAS0588  
(06 PLACES)  
13mm SOCKET**

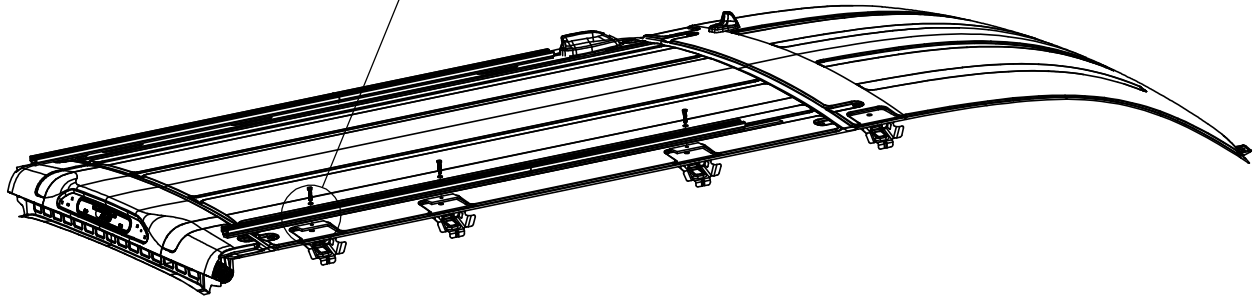
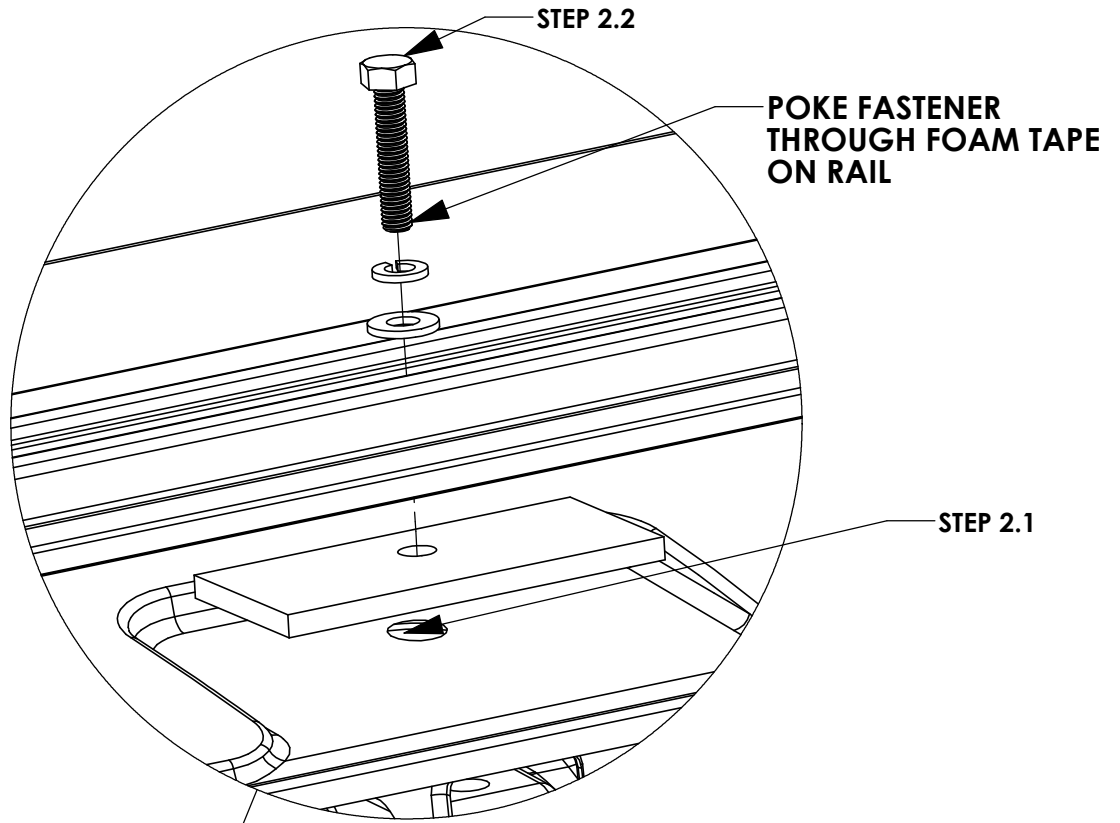

**ADD SILICONE TO FILL CAVITY OF EACH OEM WELD NUT IN  
VEHICLE ROOF AND BUTYL TAPE UNDER WASHERS ON BOLT**

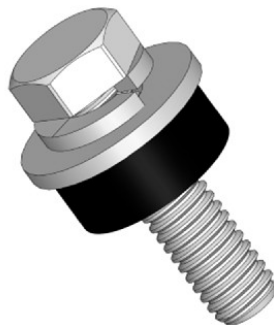

FRONT OF VEHICLE

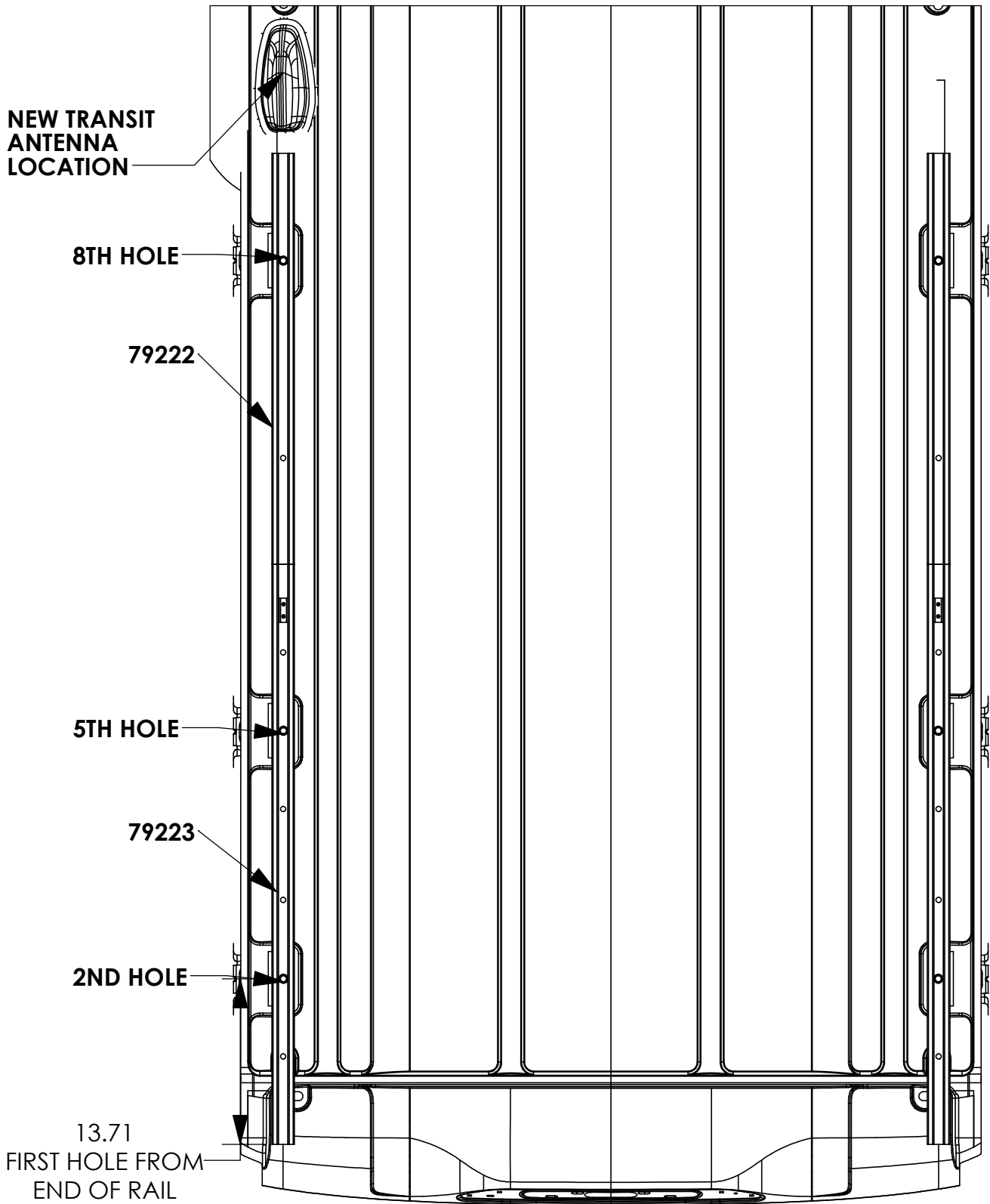

NEW TRANSIT ANTENNA  
LOCATION FORWARD ON  
ROOF  
(NOT SHOWN)

FRONT OF VEHICLE

79223

6TH HOLE

3RD HOLE

79222

2ND HOLE

25.20  
FIRST HOLE FROM  
END OF RAIL

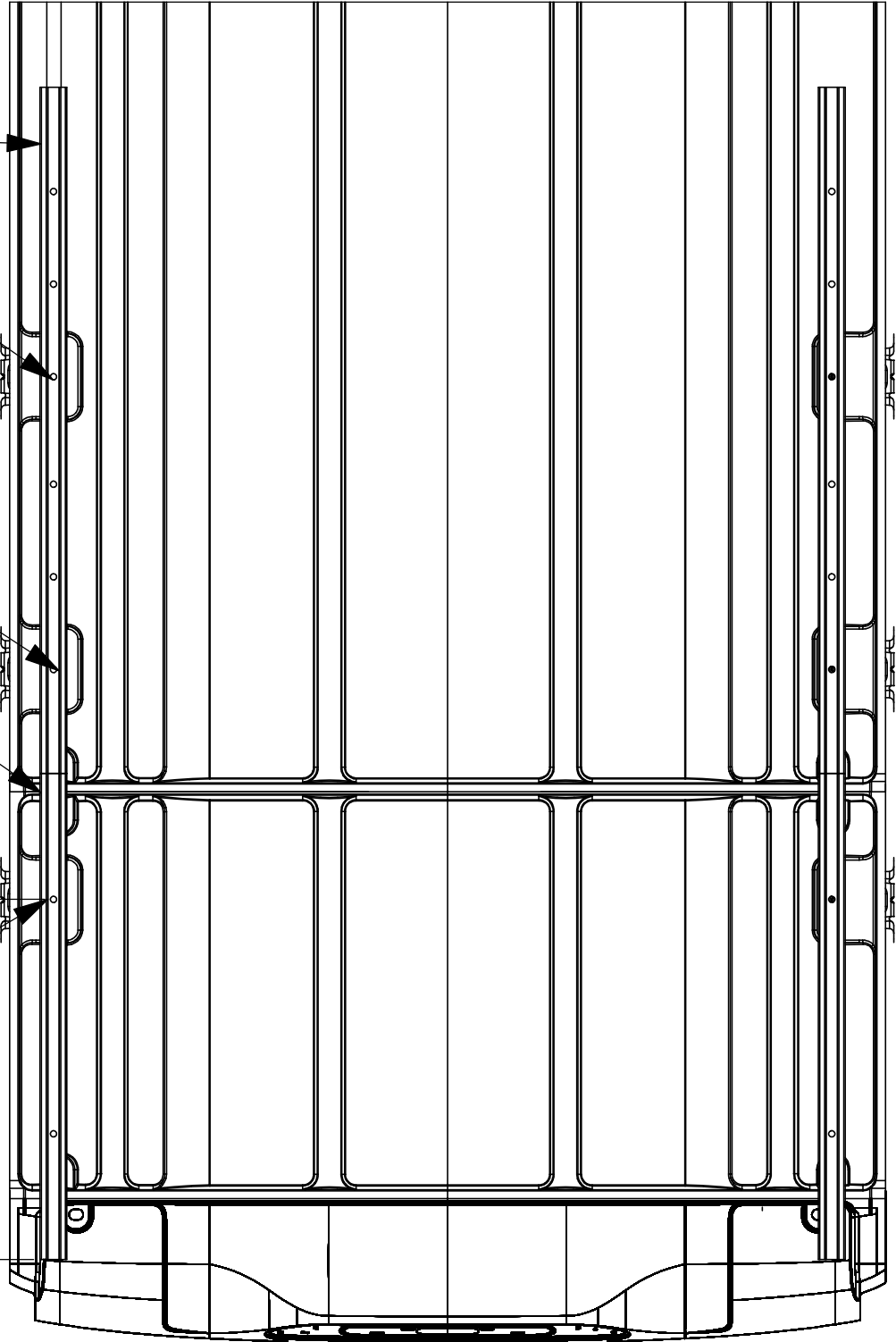

REAR OF VEHICLE



## Mounting Bracket Kit, 4-Pack, White, Multiple Pickups

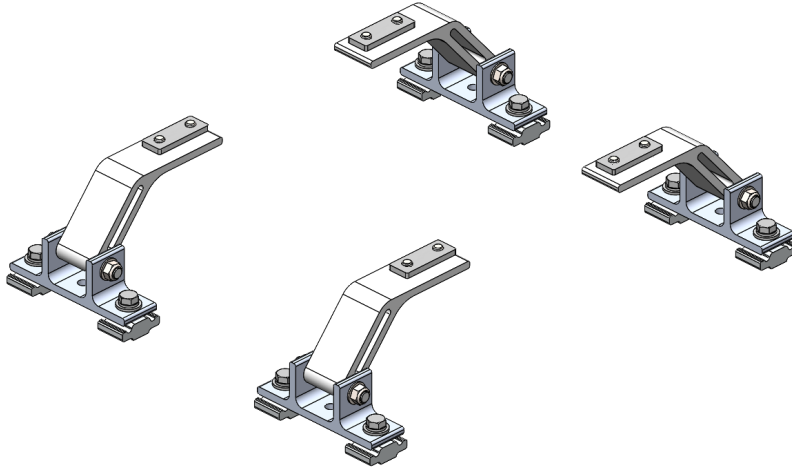

PRODUCT WEIGHT  
**4.0 LBS**

HEIGHT OFF ROOF  
**SEE TABLE BELOW**

CAPACITY  
**REFER TO OEM'S  
RECOMMENDED LOAD  
RATING**  
COLOR

**WHITE**

CATALOG NUMBER

**URMBK4W**

### PRODUCT FEATURES

**Aluminum mounting bracket kit for the PROFILE™ HD Utility, Grip-Lock, and/or ProLift ladder racks. Only works with the OEM specific, Adrian Steel supplied roof rail kit.**

**Utility and Grip-Lock racks are not recommended for medium or high roof vehicles!**

**Reference respective OEM specific roof rail kit for more detailed list of compatible accessories.**

**SEE PAGE 2 FOR APPLICATION NOTES AND ACCESSORIES, OTHER PRODUCTS THAT WORK WITH THIS UNIT.**

### PAGE 1 of 2

The information contained in this document is the sole property of ADRIAN STEEL COMPANY. ADRIAN STEEL COMPANY retains the right to modify and/or change the product of its design at any time without prior notification.



**CATALOG NUMBER      URMBK4W**

**PRODUCT APPLICATION**

**This product is designed to work with OEM specific rail kit for HD Utility, Grip-Lock, and/or ProLift racks. HD Utility and Grip-Lock racks are not recommended for medium or high roof vehicles!**

**ACCESSORIES THAT WILL WORK WITH THIS PRODUCT**

CATALOG NUMBER	DESCRIPTION	CATALOG NUMBER	DESCRIPTION
RRKFT	Mounting Roof Rail Kit, Transit	RRKNVFSV	Mounting Roof Rail Kit, NV
RRKSP	Mounting Roof Rail Kit, Sprinter	RRKPM	Mounting Roof Rail Kit, ProMaster, 118" WB, 159" WB, 159" WB Extended
RRKPM136WB	Mounting Roof Rail Kit, ProMaster, 136" WB	RRKSBTOP	Mounting Roof Rail Kit, Multiple Pickups
RRKLBTOP	Mounting Roof Rail Kit, Multiple Pickups		

**Reference respective OEM specific roof rail kit for more detailed list of compatible accessories.**

INSTR. NUMBER : <b>66850</b>	PG: <b>1</b>	REV: <b>E</b>	ITEM NO.	PART NUMBER	DESCRIPTION	URMBK4W	URMBK2W
	PART NUMBER : <b>URMBK</b>		1	65123-W	UTILITY, FT MOUNT ARM, ST, W	4	2
PART DESC. : UTILITY, MNT BKT KT, RAIL			2	63852-W	UTILITY, MOUNTING BRKT, W	4	2

**-PART NUMBERS WITH "-W" SUFFIX ARE PAINTED WHITE  
-FOR BLACK MOUNTING KITS, REPLACE "-W" PARTS WITH "-B" PARTS**

**NOTE: THIS INSTRUCTION IS VALID FOR THE FOLLOWING KITS:**

- URMBK4W
- URMBK4B
- URMBK2W
- URMBK2B

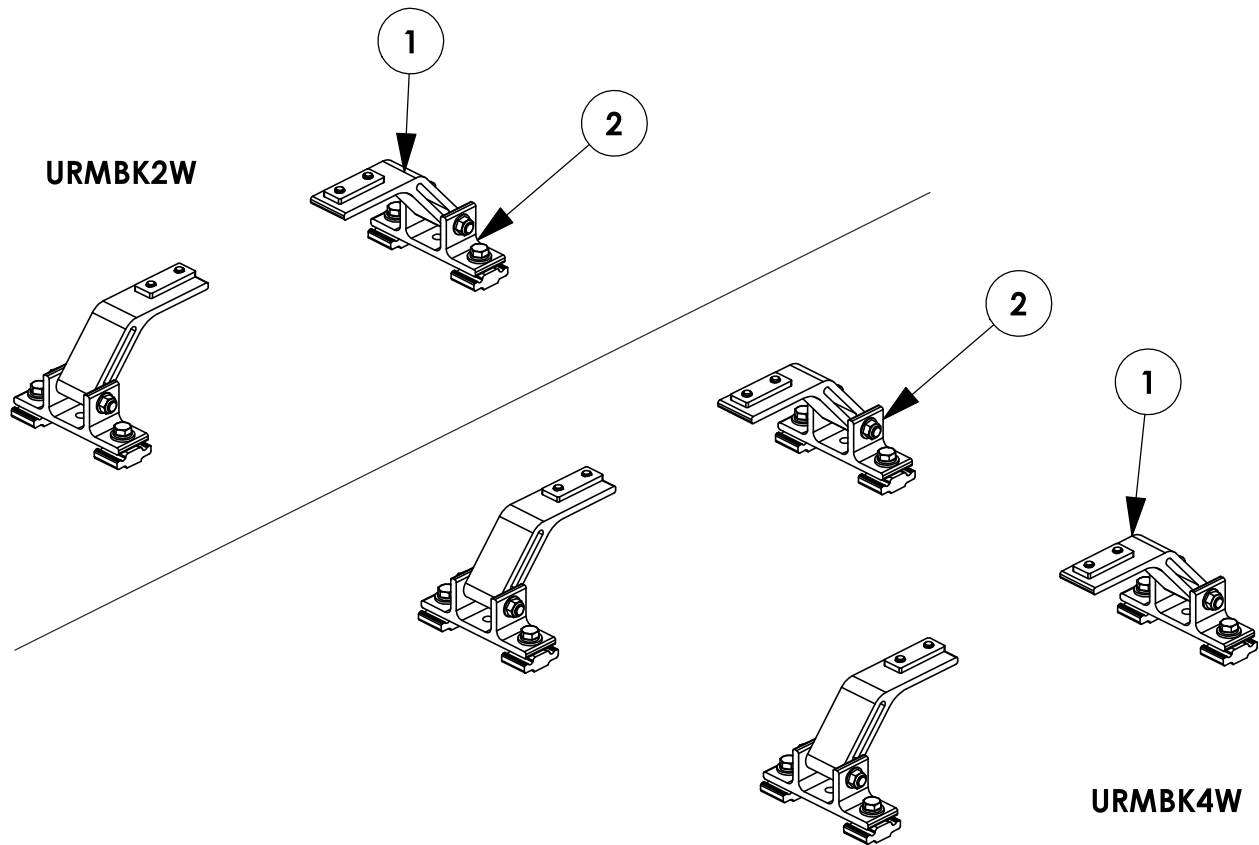

**TOOLS NEEDED:**

- DRIVE RATCHET
- IMPACT DRIVER
- 3/16" SOCKET
- 1/2" SOCKET
- 1/2" WRENCH
- TAPE MEASURE

**GET TO KNOW THE VEHICLE** - AT THE BEGINNING OF ANY INSTALLATION, CHECK THE LOCATION OF THE FUEL TANK, FUEL LINES, BRAKE LINES, HIGH VOLTAGE BATTERIES AND WIRING HARNESSSES TO AVOID INJURY OR PROPERTY DAMAGE FROM TOOL CONTACT.

**SEAL ALL EXTERIOR HOLES** - ALL INSTALLATION HOLES SHOULD BE SEALED WITH BUTYL TAPE OR SILICON TO PREVENT WATER AND EXHAUST GASES FROM ENTERING THE VEHICLE.

**CONTROL DRILL DEPTH** - TO AVOID DAMAGE TO THE VEHICLE, USE A DRILL STOP OR CLEARED STEP BIT WHEN DRILLING INSTALLATION HOLES.

**ALWAYS ADD PRIMER** - WHEN ADDING INSTALLATION HOLES BE SURE TO USE A SELF-ETCHING PRIMER TO PREVENT CORROSION, FASTENER FAILURE AND INJURY.

**MOUNTING POINTS MUST HAVE METAL-TO-METAL CONTACT** - USE PROVIDED MOUNTING SPACERS TO ACCOMMODATE FOR VEHICLE FEATURES, CARPET OR SUBFLOORS.

**PROVIDE CLEARANCE FOR SPACERS** - IF THE INSTALLATION VEHICLE CONTAINS A CARPET OR SUBFLOOR, USE A 1-3/16" DIAMETER CARPET CUTTER (P/N: 31183-0) AT ALL MOUNTING LOCATIONS TO OPEN UP ROOM FOR SPACERS.

**CHECK SPACER ORIENTATION** - BE SURE THAT THE INDENT IN THE SPACER COVERS THE PLUSNUT HEAD; THIS ENSURES THE MOST METAL-TO-METAL CONTACT AND REDUCES VIBRATION.

**PLUSNUT INSTALLATION** - A PLUSNUT GUN IS RECOMMENDED FOR PLUSNUT INSTALLATION FOR ITS PRODUCTION SPEED. HOWEVER, A PLUSNUT SETTING TOOL CAN ALSO BE USED (P/N: 22200-0).

**THRU-BOLT CLEARANCE** - WHEN USING A THRU-BOLT AT ANY MOUNTING LOCATION, BE SURE THAT YOUR HOLE HAS 1/16" CLEARANCE.

**FASTENERS AND HARDWARE USED**

**BAG REFERENCE: BAG66848**

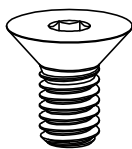

**FAS0858**  
**5/16-18X.63**  
**FHH SCREW**  
**QTY: 8**

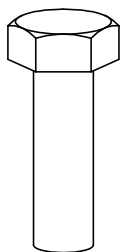

**FAS0597**  
**5/16-18X1.0 SS**  
**HH SCREW**  
**QTY: 8**

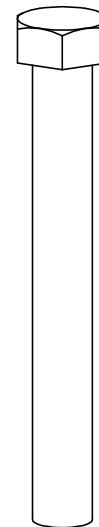

**FAS0243**  
**5/16-18X2.5 SS**  
**HH SCREW**  
**QTY: 4**



**FAS0857**  
**5/16 SS WASHER,**  
**LOCK EXT CS**  
**QTY: 8**



**FAS0588**  
**5/16 SS**  
**SPLIT WASHER**  
**QTY: 8**



**FAS0552**  
**5/16 SS**  
**FLAT WASHER**  
**QTY: 12**



**FAS0861**  
**5/16-18 SS**  
**HH FLG NUT**  
**QTY: 4**

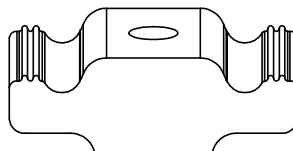

**63490**  
**RAIL SLIDE,**  
**1"**  
**QTY: 8**

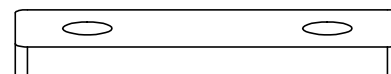

**68042**  
**PROFILE FOOT**  
**MOUNTING PLATE**  
**QTY: 4**

**PAGE INTENTIONALLY LEFT BLANK**

# STEP 1 - ASSEMBLE MOUNTING ARMS TO CROSSBOW



CHECK TABLE 1-3 IN INSTRUCTION 68895 FOR ADDITIONAL ACCESSORY SLIDE INSTALLATION BEFORE INSTALLING MOUNTING BRACKETS (ALL A.2 ITEMS SHOULD BE COMPLETELY ASSEMBLED FIRST!)

STEP 1.1  
LOOSELY ASSEMBLE  
UNTIL AFTER STEP 3  
(2) FAS0857, (2)  
FAS0858, 68042

(02 PLACES PER  
CROSSBOW)  
3/16" ALLEN

## ATTENTION!

IF INSTALLING A GRIP-LOCK ON A PICKUP TRUCK TOPPER, ASSEMBLE MOUNTING ARMS FACING OUTWARD FOR THAT SIDE OF THE RACK

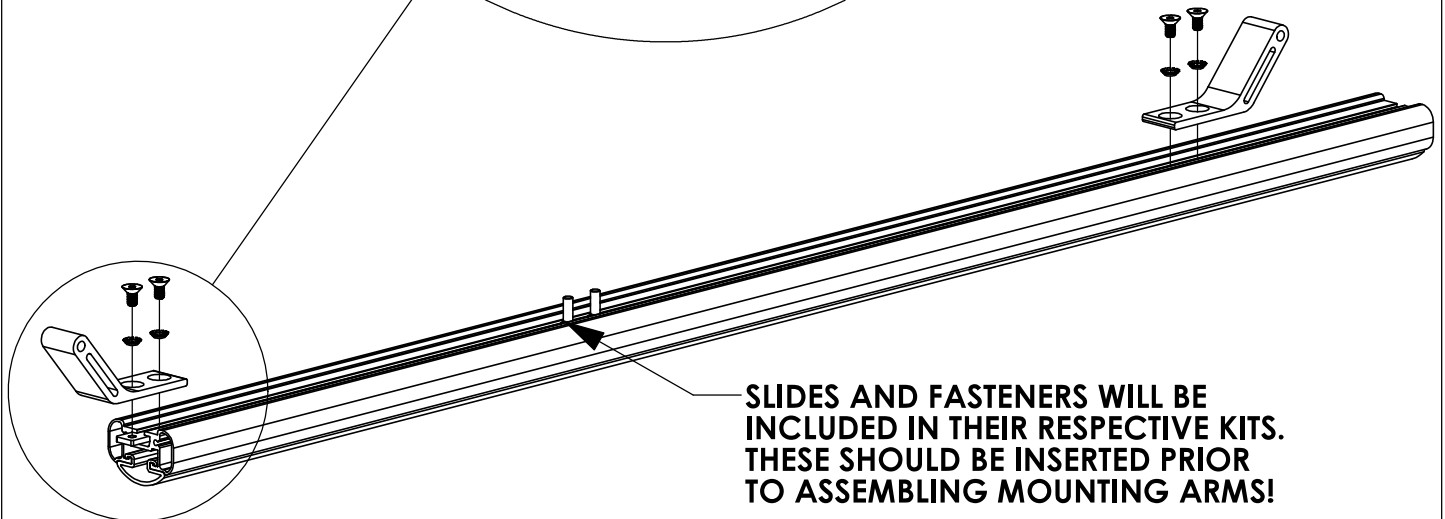
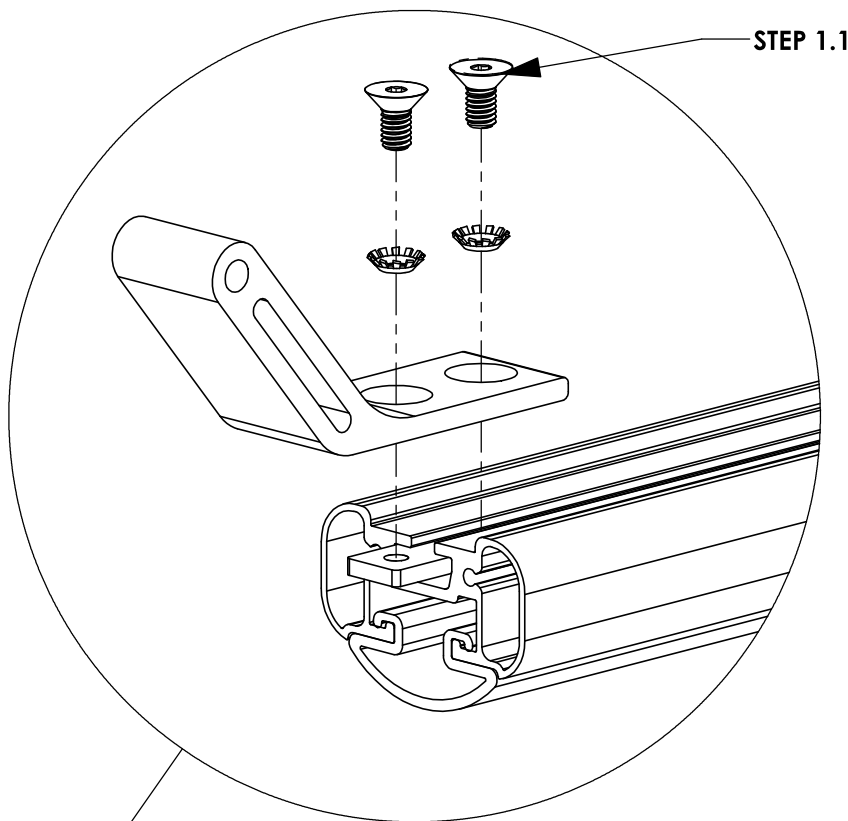

**STEP 2 - SECURE CROSSBOW**

**FULL SIZE VANS**

**CENTER CROSSBOW ON MOUNTING BRACKETS**

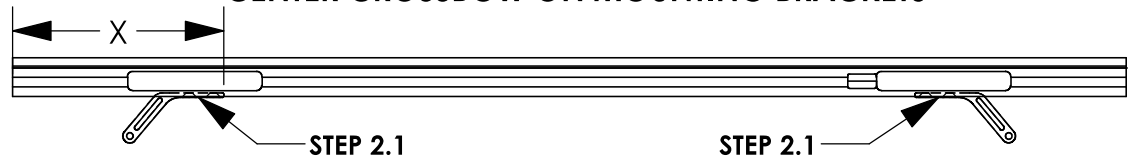

**STEP 2.1**  
**FULLY TIGHTEN**  
**FROM STEP 1.1**  
  
**(04 PLACES PER**  
**CROSSBOW)**  
**3/16" ALLEN**

VEHICLE PLATFORM	DIMENSION "X" (in.) - 58" CROSSBOW	DIMENSION "X" (in.) - 68" CROSSBOW
FORD TRANSIT	6 5/8"	11 5/8"
RAM PROMASTER	6"	11"
NISSAN NV	4 7/8"	9 7/8"
MERCEDES SPRINTER (LOW ROOF)	4 5/8"	9 5/8"
MERCEDES SPRINTER (HIGH ROOF)	8 1/8"	13 1/8"

**DIMENSION WILL VARY**  
**BASED ON ROOF RAIL**  
**PLACEMENT ON**  
**TOPPER**

**PICKUP TRUCK TOPPERS**

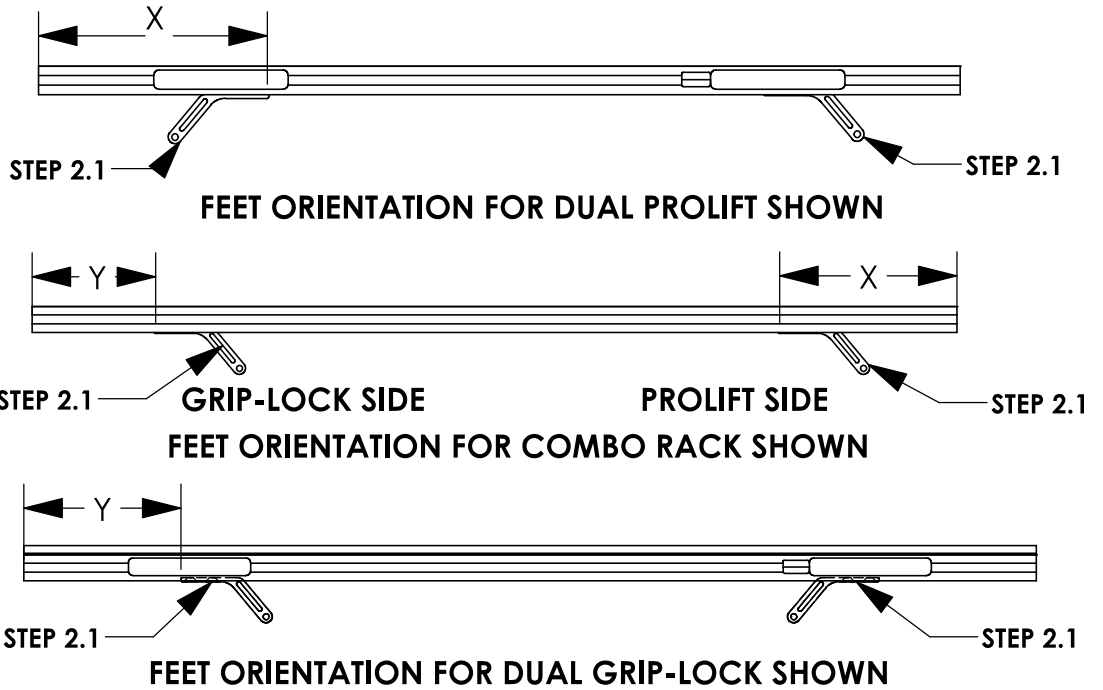

**MOUNTING FEET**  
**FOR GRIP LOCK SIDE**  
**OF COMBO RACK**  
**WILL FACE**  
**OUTWARD FROM**  
**ROOF CENTERLINE**  
**ON TOPPER**

CROSSBOW LENGTH	DIMENSION "X" (in.) - PROLIFT	DIMENSION "Y" (in.) - GRIPLOCK
48" (PROLIFT)	MINIMUM 10 1/8"	N/A
53" (COMBO)	MINIMUM 10 1/8"	MAX 7 1/8"
58" (GRIP-LOCK)	N/A	MAX 7 1/8"

**NOTE - THESE DIMENSIONS ARE APPROXIMATE AND WILL VARY SLIGHTLY WITH ANY TOLERANCE IN THE BUILD OF THE VEHICLE**

**STEP 3 - ASSEMBLE LOWER MOUNTING FOOT TO ROOF RAIL**

**STEP 3.1**  
**FULLY TIGHTEN**  
 FAS0597, FAS0552,  
 FAS0588, 63490 ON  
 REAR MOUNTING FEET

(02 PLACES PER  
 MOUNTING FOOT)  
 1/2" SOCKET

**STEP 3.2**  
**LEAVE LOOSE UNTIL**  
**AFTER STEP 4**  
 FAS0597, FAS0552,  
 FAS0588, 63490 ON  
 FRONT MOUNTING FEET

(02 PLACES PER  
 MOUNTING FOOT)  
 1/2" SOCKET

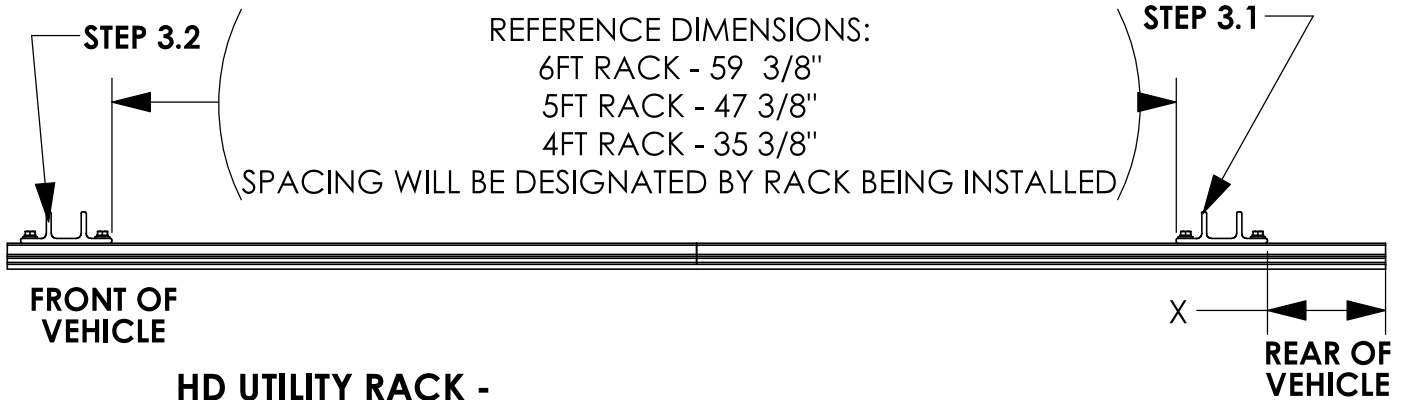
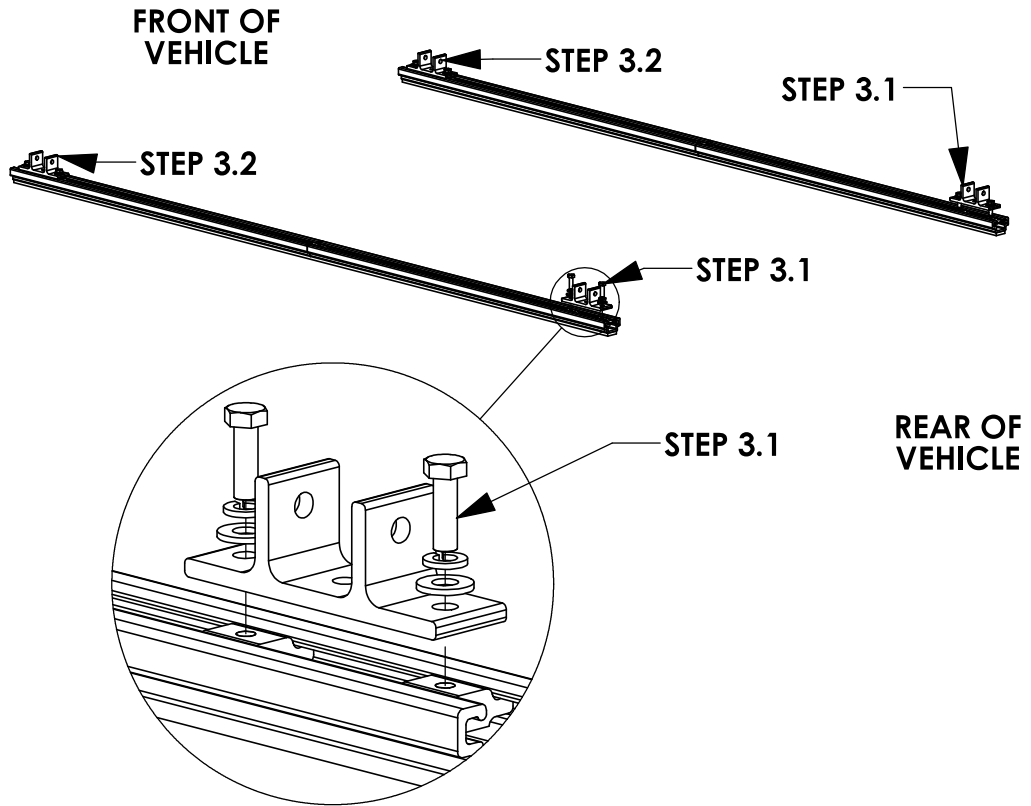

**HD UTILITY RACK -**

**REAR CROSSBOW - REARWARD AS POSSIBLE**

**FRONT CROSSBOW- POSITION TO BEST FIT END USER'S PRODUCT**

FORD TRANSIT		RAM PROMASTER		MERCEDES SPRINTER	
ROOF HEIGHT/ WHEELBASE	POSITION X (IN)	ROOF HEIGHT/ WHEELBASE	POSITION X (IN)	ROOF HEIGHT/ WHEELBASE	POSITION X (IN)
LOW ROOF	7.5	LR 118	10	LR 144	10.5
MID ROOF	7.5	LR 136	10	HR 144	12.5
HIGH ROOF	7.5	HR 136	10	HR 170	12.5
HIGH ROOF EXT	7.5	HR 159/159 EXT	10	HR 170 EXT	12.5

# STEP 4 - ASSEMBLE MOUNTING BRACKETS TO MOUNTING ARMS



**BEFORE PROCEEDING WITH THIS STEP FINISH ASSEMBLING ACCESSORIES ONTO RACK. (IE GRIP LOCK, PROLIFT, ETC)**

## STEP 4.1

### FULLY TIGHTEN

FAS0243, FAS0552,  
FAS0861

(02 PLACES PER  
CROSSBOW)

1/2" SOCKET  
1/2" WRENCH

## STEP 4.2

### FULLY TIGHTEN

FAS0597, FAS0552,  
FAS0588, 63490 ON  
FRONT MOUNTING  
FEET

(02 PLACES PER  
MOUNTING FOOT)

1/2" SOCKET

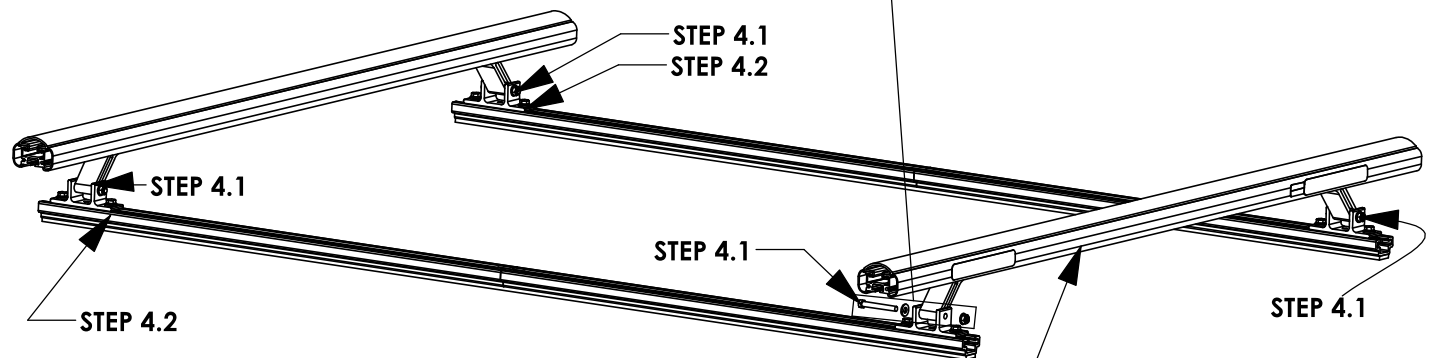
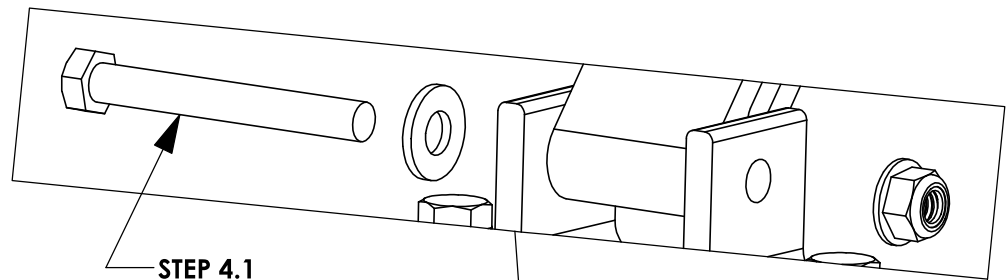

**NOTE ORIENTATION OF LABELS ON CROSSBOW**

**REFERENCE - NO ACCESSORIES SHOWN**

**STEP 5 - ADJUST MOUNTING BRACKET LOCATION IF NECESSARY**

**CROSSBOW POSITIONING NOTES:**

**HD UTILITY RACK -**

REAR CROSSBOW - REARWARD AS POSSIBLE  
 FRONT CROSSBOW- POSITION TO BEST FIT END USER'S PRODUCT

**GRIP LOCK/PROLIFT LADDER RACKS -**

1/2" FROM END OF RAIL UNLESS OTHERWISE STATED IN RESPECTIVE INSTRUCTION FOR CROSSBOW PLACEMENT.

**6' ARE TOPPER / 8' LEER TOPPER**

**A** OPTIMAL RAIL KIT POSITION:  
 TOPPER ROOF RAIL KIT END TO BE  
 A-DIM FROM BLACK TOPPER TRIM

**B** UTILITY MOUNTING BRACKET:  
 REAR MOUNTING BRACKETS WILL  
 BE B-DIM FROM THE END OF THE  
 ROOF RAIL KIT

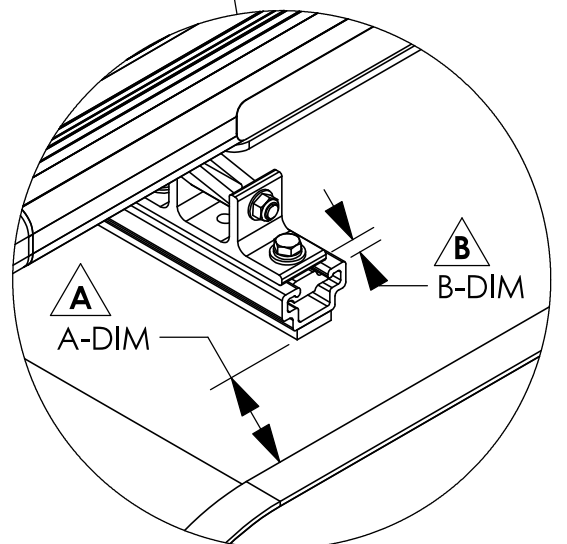
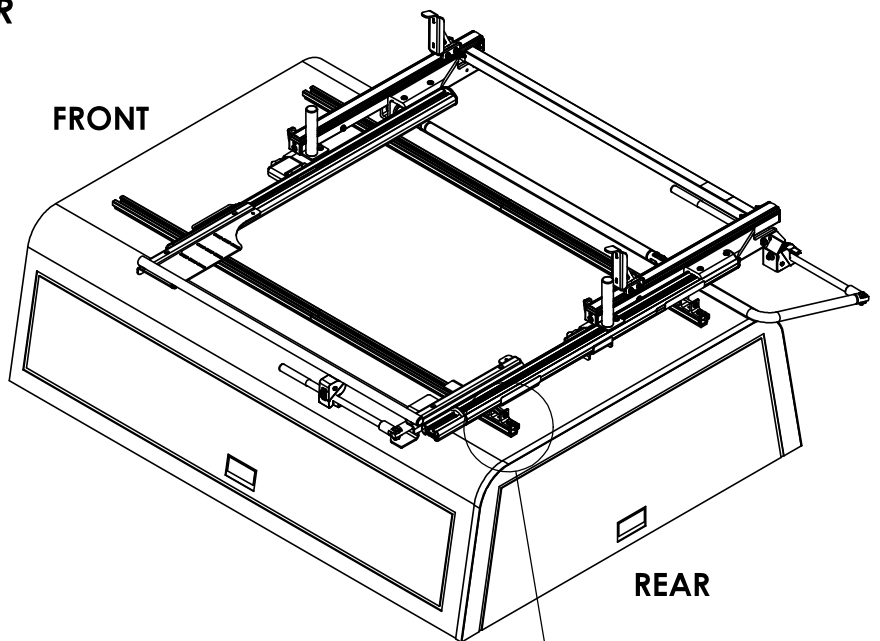

TOPPER/ DIMENSION	6' ARE TOPPER	8' LEER TOPPER
A-DIM	3.00"	1.00"
B-DIM	0.50"	0.50"

**NOTE:**  
 IF RAILS HAVE BEEN PREVOIUSLY INSTALLED, LOOSEN TOPPER RAIL BRACKET RAIL SLIDES  
 AND ADJUST TO MEET DESIRED POSITIONING

**INSTALLATION IS COMPLETE!! MAKE SURE ALL FASTENERS ARE TIGHTENED**



## 2-Crossbar Kit, 58", White, Minivan



PRODUCT WEIGHT  
**16.1 LBS**

CROSSBOW LENGTH X  
HEIGHT

**59" x 2"**

CAPACITY

**REFER TO OEM'S  
RECOMMENDED LOAD  
RATING**

COLOR

**WHITE**

CATALOG NUMBER

**2BARCW**

### PRODUCT FEATURES

Aluminum base 2-crossbow kit for PROFILE™ HD Utility, grip lock, drop down, or combo ladder racks. Works with all compact van platforms for each respective wheelbase and Ford Transit Ship Thru. Works with and without OEM specific rail kit and generic mounting bracket kits.

Optional uprights and conduit kits available.

Please refer to OEM specific mounting kit or rail kit for additional information on compatible accessories.

# INSTALLATION GUIDE FOR PROFILE™ SERIES LADDER RACKS

INSTRUCTION #:  
**68895**

REV:  
**C**



THIS INSTRUCTION PROVIDES A GENERAL GUIDE OF INSTALLATION SEQUENCE FOR ALL PROFILE™ SERIES LADDER RACKS. PLEASE ENSURE ALL ACCESSORIES ARE INSTALLED PER TYPE OF RACK BEFORE PROCEEDING TO NEXT PAGE.

REFERENCE THIS INSTRUCTION THROUGHOUT THE ENTIRETY OF YOUR INSTALL TO PREVENT ACCESSORIES BEING INSTALLED INCORRECTLY/OUT OF SEQUENCE!

*STEPS 2T - 8T ON PAGE 3 IS THE RECOMMENDED ASSEMBLY SEQUENCE FOR A FULL TABLE ASSEMBLY BEFORE INSTALLING ON THE ROOF OF THE VEHICLE.*

*STEPS 2R - 8R ON PAGE 4 IS AN ALTERNATE ASSEMBLY SEQUENCE TO INSTALL THE RACK ON THE VEHICLE ROOF AS IT IS BUILT.*

PLEASE SELECT THE ASSEMBLY SEQUENCE THAT BEST WORKS FOR YOU!

## ASSEMBLY STEPS:

**STEP 1A.** *SUB-ASSEMBLE EACH CROSSBOW WITH DESIRED ACCESSORIES FOR SECTIONS A.1 & A.2.*

*INSTRUCTIONS FOR EACH KIT CAN BE FOUND IN THEIR RESPECTIVE CARTON!*

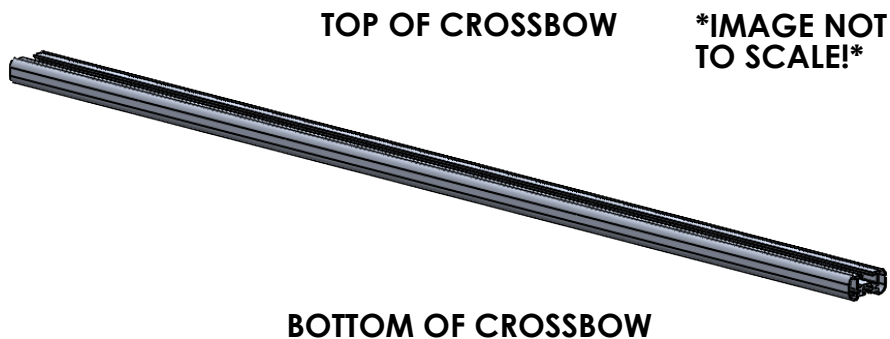

## TABLE 1

### TOP OF CROSSBOW

#### COMPONENTS TO INSTALL

A.1	HD UTILITY	- CONDUIT KIT OR BEACON
	Grip-Lock	- CONDUIT KIT OR BEACON
	ProLift	- CONDUIT KIT OR BEACON

### BOTTOM OF CROSSBOW

#### COMPONENTS TO INSTALL

A.2	HD UTILITY	- LADDER STOP, STROBE BRACKET, AND/OR REAR ROLLER
	Grip-Lock	- Grip-Lock SUB-ASSEMBLY
	ProLift	- DAMPER BRACKET

**STEP 1B. SUB-ASSEMBLE EACH CROSSBOW WITH DESIRED ACCESSORIES FOR SECTIONS B.1 & B.2. INSTRUCTIONS FOR EACH KIT CAN BE FOUND IN THEIR RESPECTIVE CARTON!**

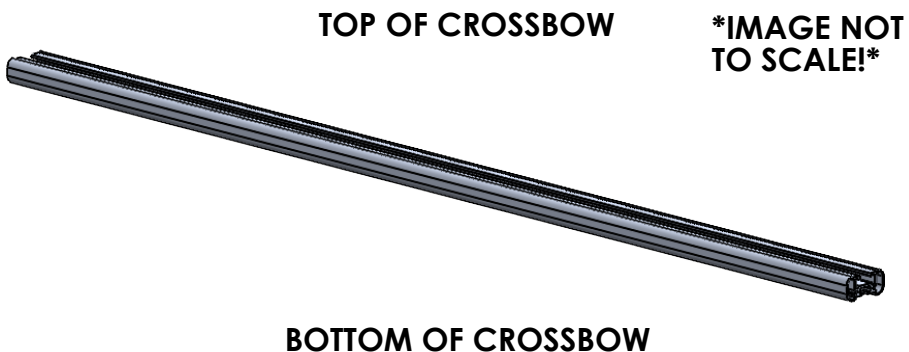

**ALTER WEAR STRIP AND INSTALL ON CROSSBOW (IF APPLICABLE)! REFERENCE TABLE 3 BELOW FOR WEAR STRIP ALTERATION INSTRUCTIONS!**

**TABLE 3**

ADDED ACCESSORIES	ALTERATION FOR WEAR STRIP
4" UPRIGHT***	REMOVE 2" FROM END OF WEAR STRIP
4" PVC CONDUIT KIT	REMOVE 7.25" FROM CENTER OF WEAR STRIP
6" PVC CONDUIT KIT	REMOVE 9.50" FROM CENTER OF WEAR STRIP
ALUMINUM BOX CONDUIT KIT	REMOVE 13.25" FROM CENTER OF WEAR STRIP
BEACON	REMOVE 4" FROM CENTER OF WEAR STRIP
ProLift (SINGLE SIDE)	CUT WEAR STRIP IN HALF, DO NOT INSTALL ON ProLift SIDE
ProLift (DUAL SIDE)	DO NOT INSTALL WEAR STRIP

**TABLE 2**

TOP OF CROSSBOW		
COMPONENTS TO INSTALL		
<b>B.1</b>	HD UTILITY	- WEAR STRIP (MODIFY IF NECESSARY, TABLE 3)
	Grip-Lock	- WEAR STRIP (MODIFY IF NECESSARY, TABLE 3)
	ProLift	- INNER STOP POST
BOTTOM OF CROSSBOW		
COMPONENTS TO INSTALL		
<b>B.2</b>	HD UTILITY	- MOUNTING BRACKETS
	Grip-Lock	- MOUNTING BRACKETS
	ProLift	- MOUNTING BRACKETS

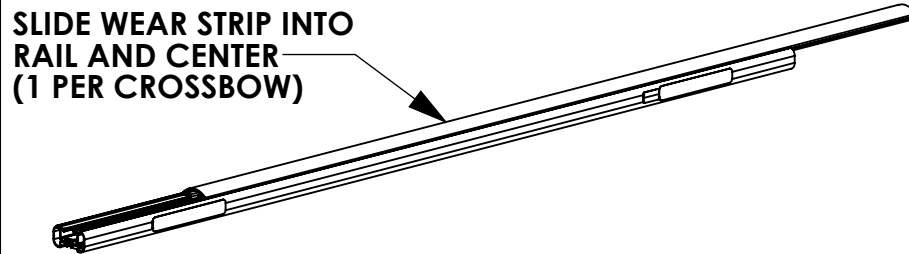

**SLIDE ONE SIDE OF WEAR STRIP INTO CROSSBOW, THEN ROLL OTHER SIDE TO SNAP STRIP INTO PLACE**

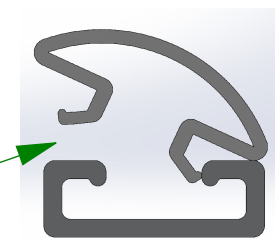

**STEP 1C SUB-ASSEMBLE EACH CROSSBOW WITH DESIRED ACCESSORIES FOR SECTIONS C.1 & C.2**

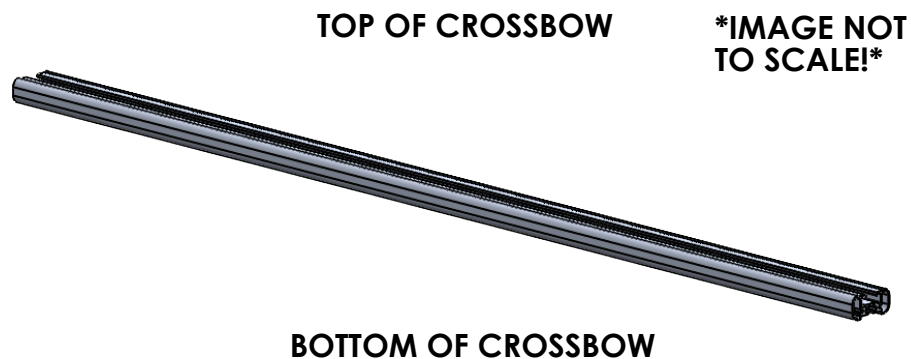

**TABLE 4**

TOP OF CROSSBOW		
COMPONENTS TO INSTALL		
C.1	HD UTILITY	- 4" UPRIGHT
	Grip-Lock	- N/A
	ProLift	- SLIDES FOR BASE EXTRUSION
BOTTOM OF CROSSBOW		
COMPONENTS TO INSTALL		
C.2	HD UTILITY	- UPRIGHTS (6", 9", RATCHET)
	Grip-Lock	- STROBES
	ProLift	- STROBES

**ASSEMBLY STEPS (FULL BENCH ASSEMBLY):**

- 2T. ADD DRIVELINES (IF INSTALLING ProLift)
- 3T. ADD HANDLES (IF INSTALLING Grip-Lock OR ProLift) AND DAMPERS (IF INSTALLING ProLift)
- 4T. ADD OUTER SUPPORT BARS (IF INSTALLING Grip-Lock OR ProLift)
- 5T. ADD STEP LADDER KIT (Grip-Lock OR ProLift ONLY!)

**6T. ASSEMBLE ENDS CAPS TO CROSSBOW**

USED FOR HD UTILITY & Grip-Lock RACKS

LOCATED IN CROSSBOW KIT

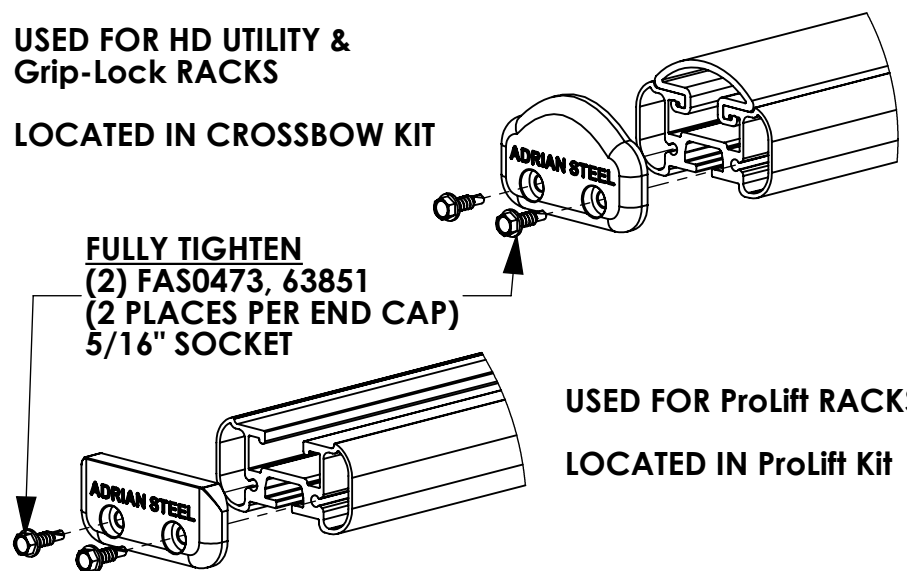

**FULLY TIGHTEN  
(2) FAS0473, 63851  
(2 PLACES PER END CAP)  
5/16" SOCKET**

USED FOR ProLift RACKS  
LOCATED IN ProLift Kit

**7T. INSTALL ROOF RAIL KIT ON VEHICLE ROOF OR BOTTOM MOUNTING BRACKETS**

(ROOF RAIL KIT REQUIRED FOR Grip-Lock & ProLift OPTIONAL FOR HD UTILITY, NOT NEEDED FOR GM LADDER RACKS)

**8T. MOUNT CROSSBOW SUB-ASSEMBLIES FROM STEP 1 TO VEHICLE/MOUNTING BRACKET, OR ROOF RAIL (LOOSE INSTALL)**

**ALTERNATE ASSEMBLY METHOD!**  
**(ASSEMBLE ON VEHICLE ROOF):**

2R. INSTALL ROOF RAIL KIT ON VEHICLE ROOF OR BOTTOM MOUNTING BRACKETS

(ROOF RAIL KIT REQUIRED FOR Grip-Lock & ProLift, OPTIONAL FOR HD UTILITY, NOT NEEDED FOR GM LADDER RACKS)

3R. MOUNT CROSSBOW SUB-ASSEMBLIES FROM STEP 1 TO VEHICLE/MOUNTING BRACKET, OR ROOF RAIL (LOOSE INSTALL)

4R. ADD DRIVELINES (IF INSTALLING ProLift)

5R. ADD HANDLES (IF INSTALLING Grip-Lock OR ProLift) AND DAMPERS (IF INSTALLING ProLift)

6R. ADD OUTER SUPPORT BARS (IF INSTALLING Grip-Lock OR ProLift)

7R. ADD STEP LADDER KIT (Grip-Lock OR ProLift ONLY!)

8R. ASSEMBLE END CAPS TO CROSSBOW

USED FOR HD UTILITY & Grip-Lock RACKS

LOCATED IN CROSSBOW KIT

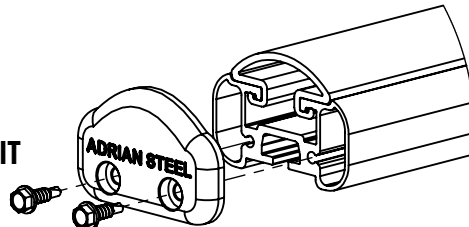

**FULLY TIGHTEN**  
**(2) FAS0473, 63851**  
**(2 PLACES PER END CAP)**  
**5/16" SOCKET**

USED FOR ProLift RACKS  
LOCATED IN ProLift Kit

