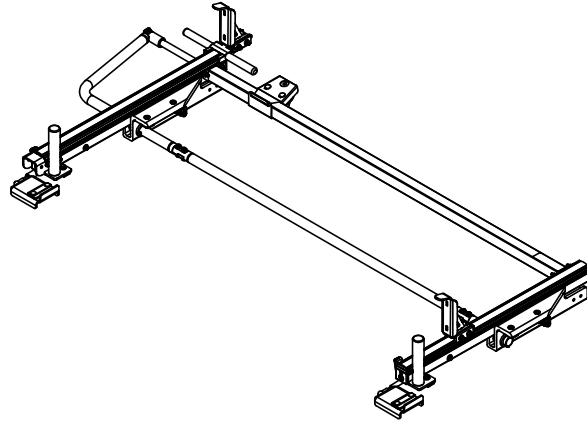

**ADRIAN STEEL®**

Cargo Management Solutions for Commercial Vehicles

# PROLIFT MAX DROP 4' DRIVERS SIDE LOW TOPPER LADDER RACKS

**PRODUCT WEIGHT****63.5 LBS****WIDTH X DEPTH X HEIGHT****82.00" X 32.00" X4.00"****CAPACITY****SINGLE LADDER****COLOR****WHITE/BLACK****CATALOG NUMBER****PLMDDSLT4W, PLMDDSLT4B****PRODUCT FEATURES**

ProLift™ Max Drop LOW Topper racks can be used on ADRIAN STEEL BIFF, LEER, UNICOVER and ARE truck toppers with bed lengths from 4'6" - 6'1" with appropriate rail kit, crossbow kit and mounting bracket kit. Use rail kits, crossbow kits, and mounting bracket kits listed in the table below to create new rack combinations. These racks include an attached handle.

The Max-Drop ProLift™ has a single function that lowers the ladder to a single set height and a secondary function that lowers the rear of the ladder even further to a safer more ergonomic height. Most similar to our previous DDLR drop-down series.

Unicover Toppers will use roof rail kits ending in UC (Ex. 4'6" Unicvoer topper would use RRKTOP55UC)

Ignore the roof rail kit when ordering racks for ASC BIFF toppers as they ship with pre-installed rails.

**Commercial Part Numbers**

Vehicle Platform	Bed Length	Bed Length (in)	Roof Rail Kit	Crossbow kit	Mounting Bracket Kit	Pro-Lift (Passenger Side)	Pro-Lift (Drivers Side)
Maverick	4'6"	54"	RRKTOP55/UC	2BARTOPW	MAVRMBK4W	PLSDPSLT4	PLSDDSLT4
All	4'10" - 5'6"	58" - 66"	RRKTOP58/UC	2BARTOPW	URMBK4W	PLSDPSLT4	PLSDDSLT4
All	5'7" - 6'1"	67"-73"	RRKTOP67/UC	2BARTOPW	URMBK4W	PLSDPSLT4	PLSDDSLT4

**NOTE:CROSSBAR KIT IS DIFFERENT FOR COMBO WITH GRIPLOCK. IN THIS CASE,USE 2BAR53W/B**

SEE PAGE 2 FOR APPLICATION NOTES, ACCESSORIES AND OTHER PRODUCTS THAT WORK WITH THIS UNIT.

**PROLIFT MAX DROP 4' DRIVERS SIDE  
LOW TOPPER LADDER RACKS****CATALOG NUMBER****PLMDDSLT4W, PLMDDSLT4B****PRODUCT APPLICATION****TOPPER PROLIFT LADDER RACKS ARE FOR USE ON PICKUP TRUCK BED TOPPERS,  
AVAILABLE IN 4 FT, 5 FT, AND 6 FT LENGTHS FOR ALL DIFFERENT SIZE TRUCK BEDS.****Reduce back and shoulder injuries while loading/unloading ladders by  
eliminating the need to climb on bumpers and tires to reach the cargo on the  
roof of your vehicle.****The ProLift™ uses unique, patent-pending, mechanical advantages, and  
high-performing spring assist struts to raise and lower ladders with an almost  
effortless pull.****ACCESSORIES THAT WILL WORK WITH THIS PRODUCT**

CATALOG NUMBER	DESCRIPTION (smart)
RRKTOP55	ROOF RAIL KIT, TOPPER, 55"
RRKTOP58	ROOF RAIL KIT, TOPPER, 58"
RRKTOP67	ROOF RAIL KIT, TOPPER, 67"
RRKTOP55UC	ROOF RAIL KIT, TOPPER, 55" UNICOVER
RRKTOP58UC	ROOF RAIL KIT, TOPPER, 58" UNICOVER
RRKTOP67UC	ROOF RAIL KIT, TOPPER, 67" UNICOVER
2BARTOPW / B	2BAR UTILITY RACK, TOP
2BAR53W / B	2BAR, CROSSBOW, 53"
URMBK4W / B	UTILITY, MNT BKT KT, RAIL
PLMDPSLT4W/B	PROLIFT, MAX, PS, LOW TOP, 4
GL-TOPPSW / B	GRIP-LOCK, TOP PS

**The information contained in this document is the sole property of ADRIAN STEEL COMPANY. ADRIAN STEEL  
COMPANY retains the right to modify and/or change the product of its design at any time with prior notification.**

INSTR. NUMBER : <b>69483</b>	PG: <b>1</b>	REV: <b>A</b>
PART NUMBER • <b>Max Drop ProLift - Low &amp; Mid-Roof</b>		
PART • ProLift Low & Mid-Roof DESC. • Adjustment Instructions		

**Step 2: With 1/2" Socket loosen nut, slide post so that it is snug against ladder  
Tighten nut**

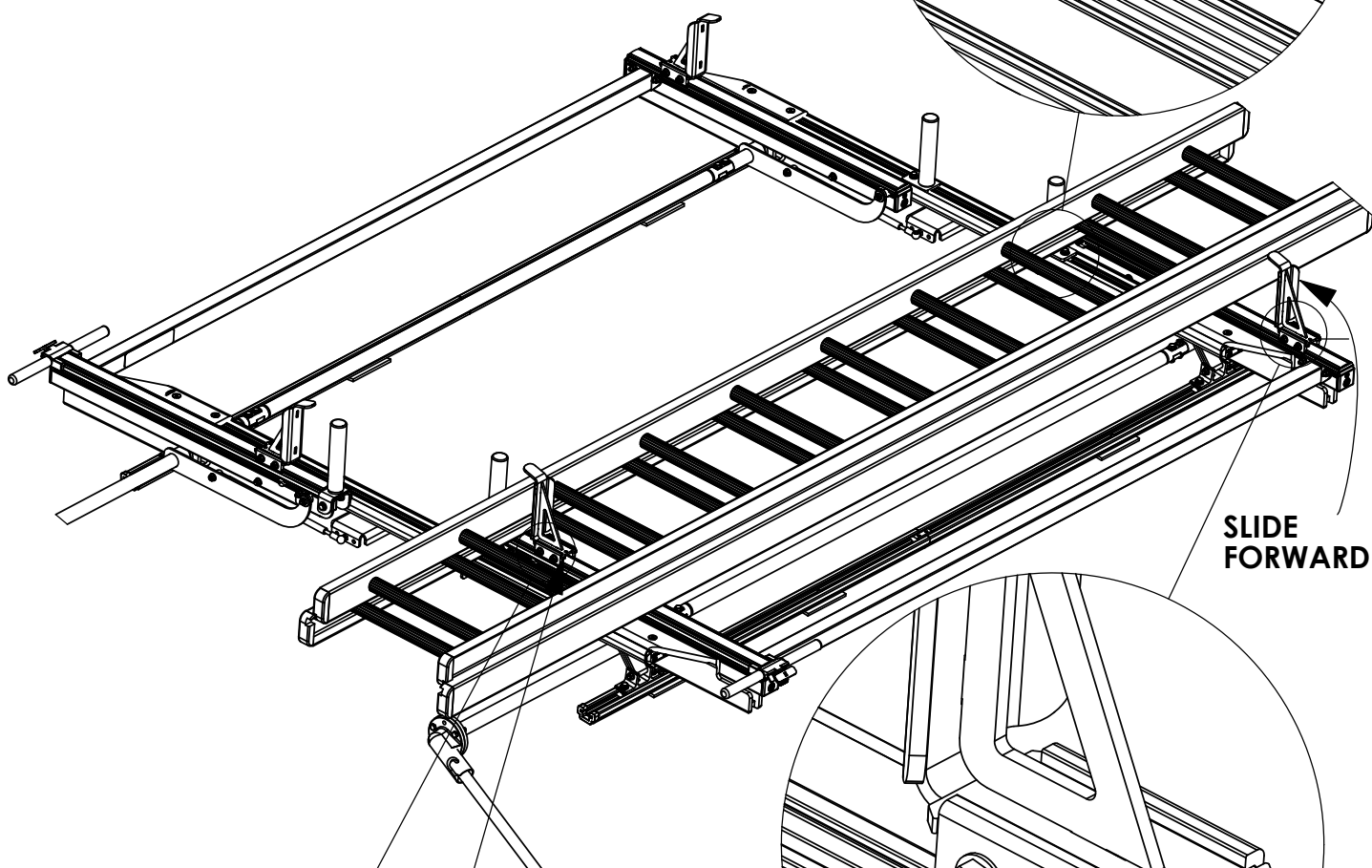
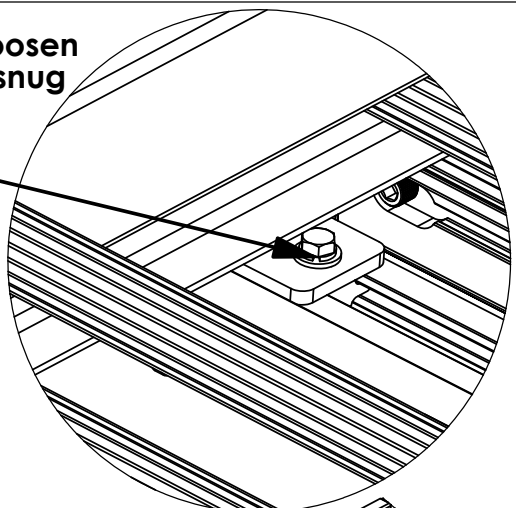

**SLIDE FORWARD**

**SLIDE FORWARD**

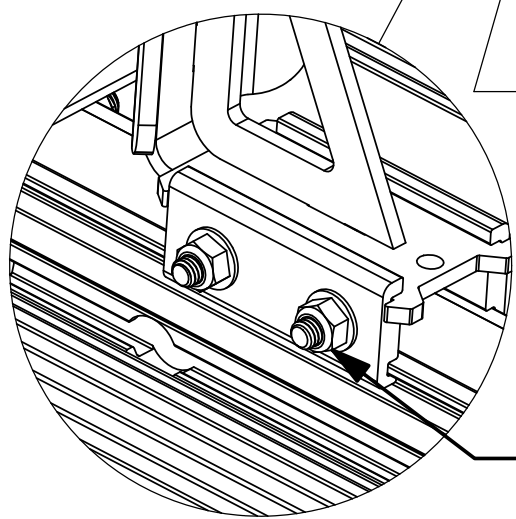

**Step 1: With 1/2" Socket loosen nuts (x2) slide clamp so that it is snug against ladder  
Tighten nuts (X2)**

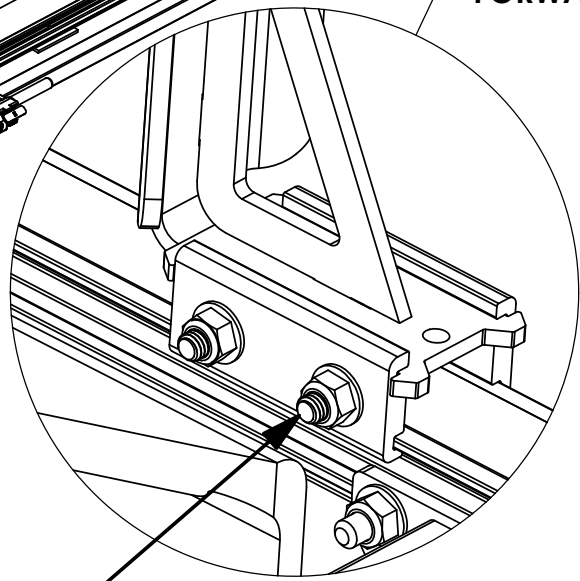

**Step 3: With 1/2" Socket loosen nuts (x2) slide clamp so that it is snug against outside of ladder  
Tighten nuts (X2)**

**Once all brackets are adjusted operate rack to make sure clamps are not too tight**

INSTR. NUMBER : <b>70119</b>	PG: <b>1</b>	REV: <b>E</b>	ITEM NO.	PART NUMBER	DESCRIPTION	PLMDPSLT	PLMDDSLT
PART NUMBER : <b>PLMDPSLT &amp; PLMDDSLT</b>			1	68037-B	CLAMP PAD, 6.5", BLACK	2	2
			2	66611-B	DROP DOWN, PIVOT HANDLE, BLK	1	1
			3	48265	DAMPER ASSEMBLY	1	1
PART DESC. : PROLIFT,MAX,PS,LT & PROLIFT,MAX,DS,LT			4	58239	COMPRESSION DAMPER	1	1
			5	65963-W	STOP CLAMP, WHITE	4	4
<b>NOTE: DRIVE LINE LIST</b>			6	68186-W	PROLIFT INNER POST, WHITE	1	1
			7	68196-W	PROLIFT MAX DROP STOP, WHITE	1	1
			8	68628-W	PROLIFT HR DAMPER MOUNT, WHITE	2	2
			9	25340-0	HANDLE LATCH-STD	1	1
			10	72698-W	PL, 6' PS, OS BAR W/ LATCH CLAMP, WHITE	1	1
			11	70107-W	PROLIFT,LMT,DR ASM,PS,R,W	-	1
			12	68031-W	DROP DOWN FRONT ARM ASSM DS, WHITE	-	1
			13	6563-B	DROP DOWN, CS CENTER DRIVELINE, BLK	-	1

<b>16</b>	
KIT PART NO.	DRIVE LINE
PLMDDSLT4	70323-B
PLMDPSLT4	7321-B
PLMDDSLT5	68419-B
PLMDPSLT5	68414-B
PLMDDSLT6	66563-B
PLMDPSLT6	66572-B

**NOTE: FRONT DROP DOWN CART.**

<b>15</b>	
KIT PART NO.	FRONT ASSEM.
PLMDDSLT4	68013
PLMDPSLT4	68031
PLMDDSLT5	68013
PLMDPSLT5	68031
PLMDDSLT6	68013
PLMDPSLT6	68031

**NOTE: REAR DROP DOWN CART.**

<b>14</b>	
KIT PART NO.	REAR ASSEM.
PLMDDSLT4	70107
PLMDPSLT4	70106
PLMDDSLT5	80065
PLMDPSLT5	80064
PLMDDSLT6	80065
PLMDPSLT6	80064

**- PART NUMBERS WITH "-W" SUFFIX ARE PAINTED WHITE  
- FOR BLACK MOUNTING KITS, REPLACE "-W" PARTS WITH "-B" PARTS**

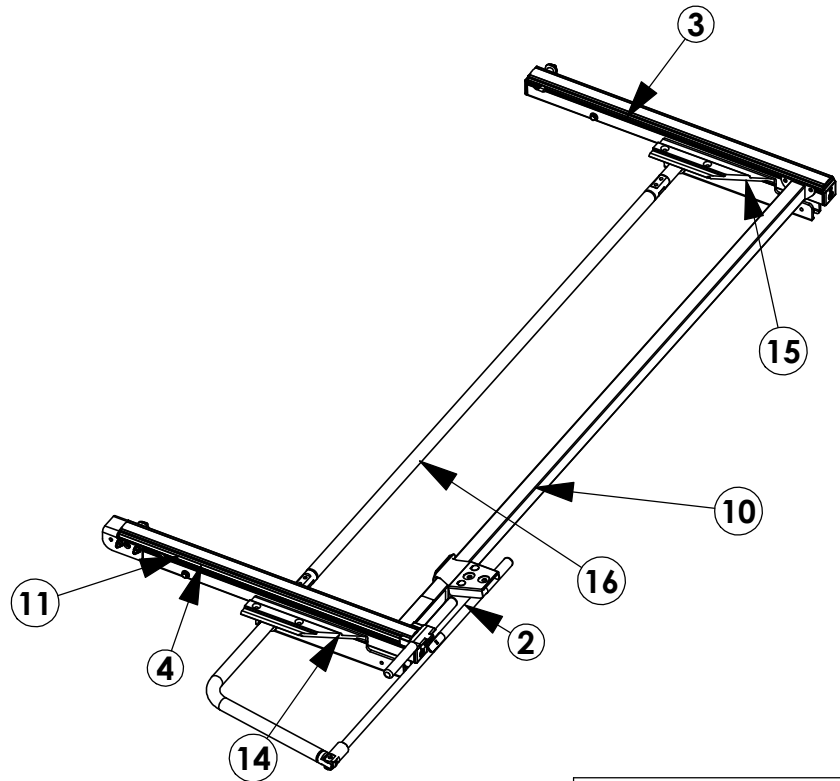

- TOOLS NEEDED:**
- 1/2" SOCKET
  - 1/2" WRENCH
  - 9/16" SOCKET
  - 3/8" SOCKET
  - DRIVE RATCHET
  - 7/32" ALLEN WRENCH
  - 3/16" ALLEN WRENCH
  - 13mm WRENCH
  - TAPE MEASURE
  - RUBBER Mallet
  - IMPACT DRIVER

**\*\*IF BUILDING A DUAL SIDED RACK BUILD BOTH SIDES IN PARALLEL FOR EACH STEP. IF BUILDING SINGLE SIDED REFERENCE ONLY THAT SIDE WHEN BUILDING.\*\***

**GET TO KNOW THE VEHICLE** - AT THE BEGINNING OF ANY INSTALLATION, CHECK THE LOCATION OF THE FUEL TANK, FUEL LINES, BRAKE LINES, HIGH VOLTAGE BATTERIES AND WIRING HARNESSSES TO AVOID INJURY OR PROPERTY DAMAGE FROM TOOL CONTACT.

**SEAL ALL EXTERIOR HOLES** - ALL INSTALLATION HOLES SHOULD BE SEALED WITH BUTYL TAPE OR SILICON TO PREVENT WATER AND EXHAUST GASES FROM ENTERING THE VEHICLE.

**CONTROL DRILL DEPTH** - TO AVOID DAMAGE TO THE VEHICLE, USE A DRILL STOP OR CLEARED STEP BIT WHEN DRILLING INSTALLATION HOLES.

**ALWAYS ADD PRIMER** - WHEN ADDING INSTALLATION HOLES BE SURE TO USE A SELF-ETCHING PRIMER TO PREVENT CORROSION, FASTENER FAILURE AND INJURY.

**MOUNTING POINTS MUST HAVE METAL-TO-METAL CONTACT** - USE PROVIDED MOUNTING SPACERS TO ACCOMMODATE FOR VEHICLE FEATURES, CARPET OR SUBFLOORS.

**PROVIDE CLEARANCE FOR SPACERS** - IF THE INSTALLATION VEHICLE CONTAINS A CARPET OR SUBFLOOR, USE A 1-3/16" DIAMETER CARPET CUTTER (P/N: 31183-0) AT ALL MOUNTING LOCATIONS TO OPEN UP ROOM FOR SPACERS.

**CHECK SPACER ORIENTATION** - BE SURE THAT THE INDENT IN THE SPACER COVERS THE PLUSNUT HEAD; THIS ENSURES THE MOST METAL-TO-METAL CONTACT AND REDUCES VIBRATION.

**PLUSNUT INSTALLATION** - A PLUSNUT GUN IS RECOMMENDED FOR PLUSNUT INSTALLATION FOR ITS PRODUCTION SPEED. HOWEVER, A PLUSNUT SETTING TOOL CAN ALSO BE USED (P/N: 22200-0).

**THRU-BOLT CLEARANCE** - WHEN USING A THRU-BOLT AT ANY MOUNTING LOCATION, BE SURE THAT YOUR HOLE HAS 1/16" CLEARANCE.

**BEST PRACTICE: ORGANIZE ALL FASTENERS & VERIFY THAT ALL ARE ACCOUNTED FOR**

PAGE:

**3**

**FASTENERS AND HARDWARE USED**

**BAG REFERENCE: BAG68181 & BAG68182**

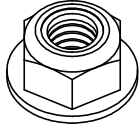

FAS0861  
NUT,HEX NLK FLG 5/16-18  
QTY: 20



FAS0110  
NUT,HEX NLK 3/8-16  
QTY: 01



FAS0399  
NUT,HEX NLK LT 3/8-16  
QTY: 01



FAS0588  
WASHER,LCK SPLIT 5/16  
QTY: 03

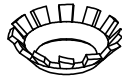

FAS0857  
WASHER,LCK EXT CS 5/16  
QTY: 04

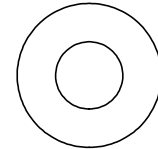

FAS0552  
WASHER,FLAT USS 5/16  
QTY: 09

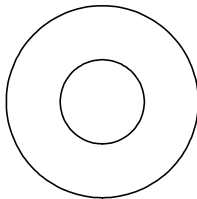

FAS0720  
WASHER,FLAT USS 3/8  
QTY: 01



FAS0283  
SCREW,HH 5/16-18X.875  
QTY: 03

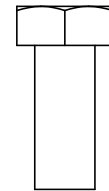

FAS0799  
SCREW,HH 5/16-18X.75  
QTY: 02

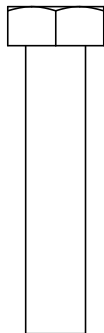

FAS0242  
SCREW,HH 5/16-18X1.5  
QTY: 04

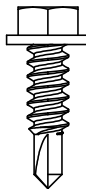

FAS0473  
SCREW,HH TEK #12X.75  
QTY: 04



FAS0856  
SCREW,FHH 5/16-18X1.13  
QTY: 04

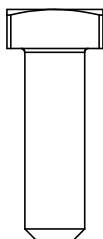

FAS0035  
BOLT,SQ HD 5/16-18X1.0  
QTY: 02

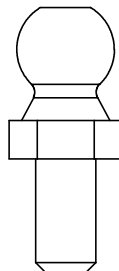

34927-0  
BALL STUD 13MM X 5/16-18  
QTY: 02

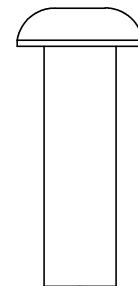

FAS0701  
SCREW,BHCS 3/8-16X1.25  
QTY: 01

**INTENTIONALLY LEFT BLANK**

**FASTENERS AND HARDWARE USED**

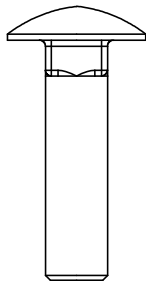

FAS0812  
BOLT,CRG 5/16-18X1.25  
QTY: 04

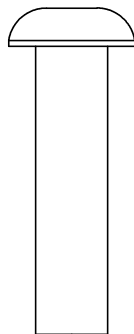

FAS0819  
SCREW,BHCS 3/8-16X1.5  
QTY: 01

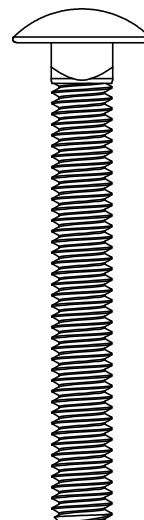

FAS0838  
BOLT,CRG 5/16-18X2.5  
QTY: 04



64831  
REAR ROLLER, SPACER  
QTY: 02

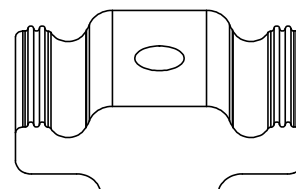

63490  
RAIL SLIDE, 1"  
QTY: 05



64830  
REAR ROLLER, BOLT PLATE  
QTY: 02



34928-0  
CLIP, SPRING, RETAINER, 13MM  
QTY: 04

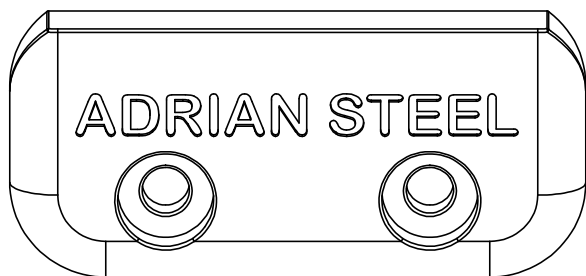

65961  
DROP DOWN END CAP  
QTY: 02

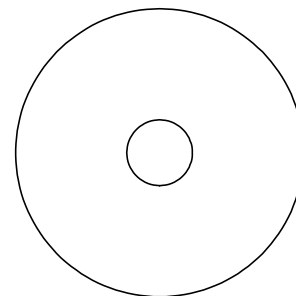

**DISCARD** FAS0603  
SCREW,HH 5/16-18X.875  
QTY: 01

**INTENTIONALLY LEFT BLANK**

# STEP 1 - MOUNT DAMPER BRACKETS

## A.2

**Step 1.1**  
**FULLY TIGHTEN**  
 34927-0 & FAS0861  
 (02 PLACES PER  
 SIDE)  
 13mm WRENCH  
 1/2" SOCKET

**STEP 1.2**  
**FULLY TIGHTEN**  
 (02) FAS0812,  
 64830, 64831, &  
 (02) FAS0861  
 (02 PLACES PER  
 SIDE)  
 1/2" SOCKET

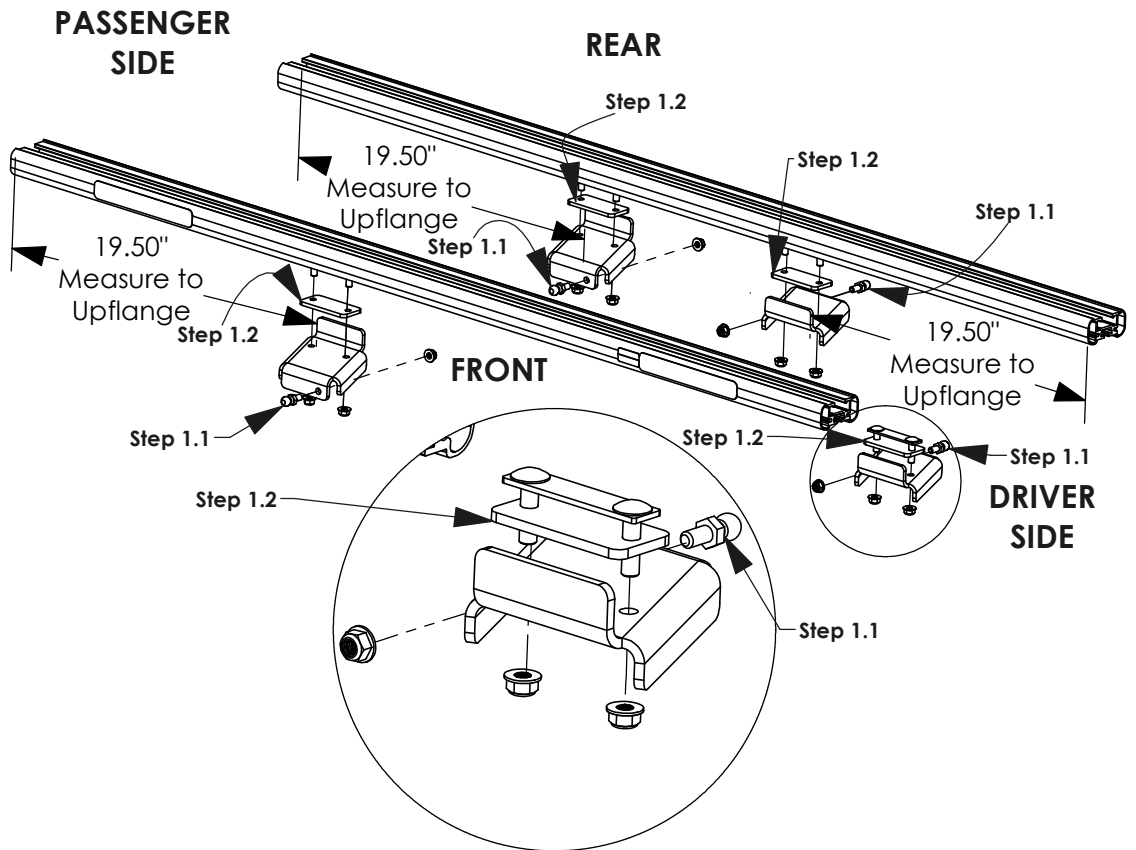

# STEP 2 - MOUNT INNER STOPS TO FRONT CROSSBOW

## B.1

**STEP 2.1**  
**FULLY TIGHTEN**  
 FAS0283, FAS0552,  
 & FAS0588, 63490  
 (01 PLACE PER  
 SIDE)  
 1/2" SOCKET

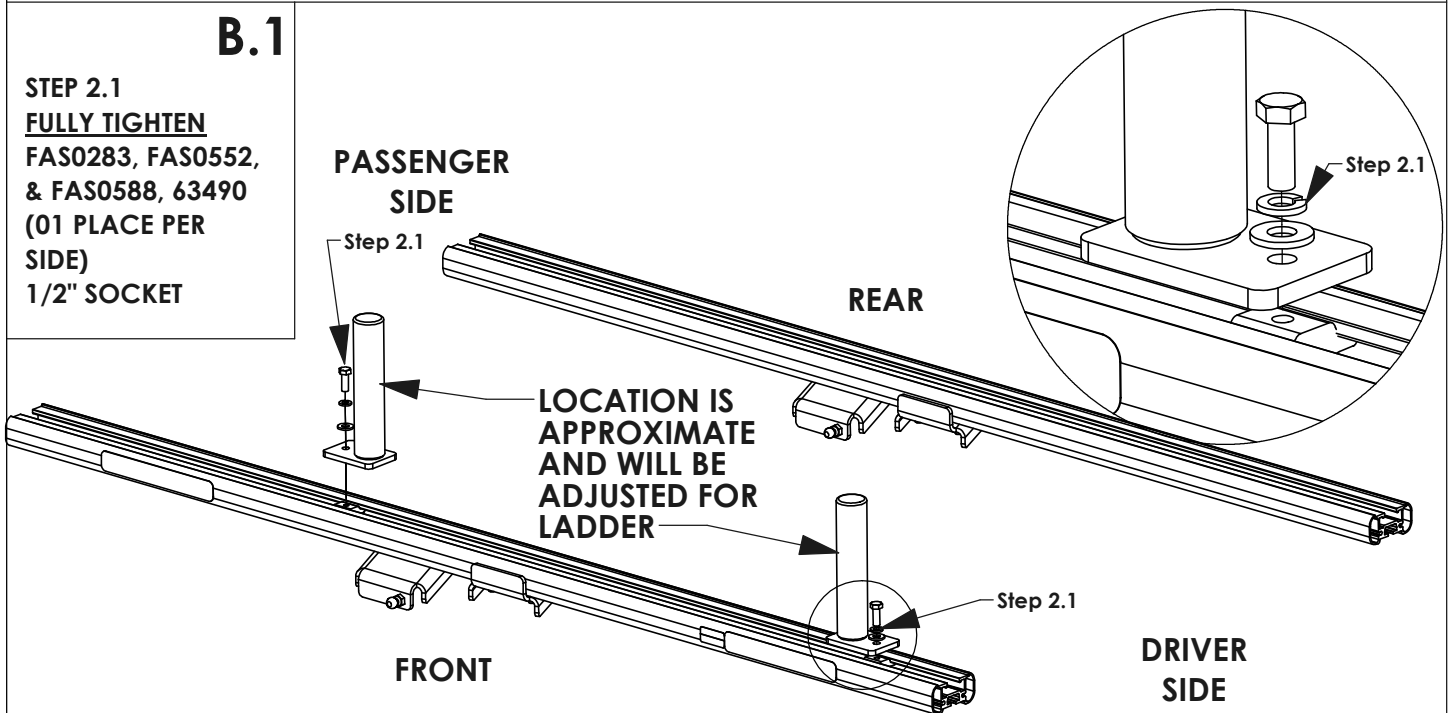

# STEP 3 - INSTALL CLAMPS AND HARDWARE ON DROP DOWN CARTRIDGES

## REAR SUB-ASSEMBLY

**STEP 3.1**  
**FULLY TIGHTEN**  
 FAS0283, FAS0552,  
 & FAS0861  
 (02 PLACES)  
 1/2" WRENCH  
 1/2" SOCKET

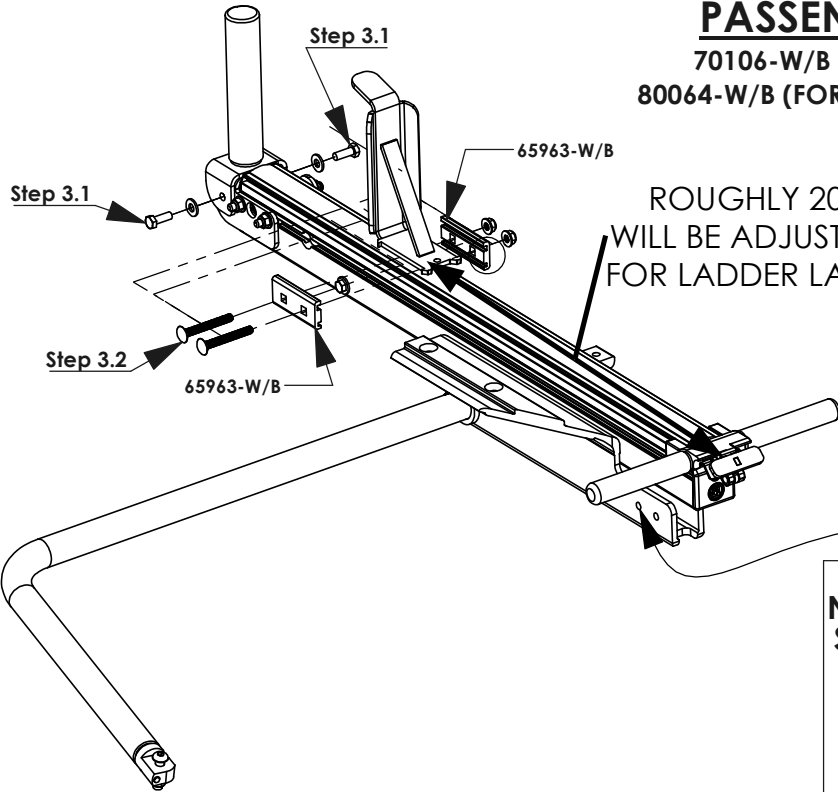

### PASSENGER SIDE

70106-W/B (FOR LT4 MODELS)  
 80064-W/B (FOR LT5 AND LT6 MODELS)

**NOTE ORIENTATION:**  
 SMALLER CHANNEL  
 ON BOTTOM

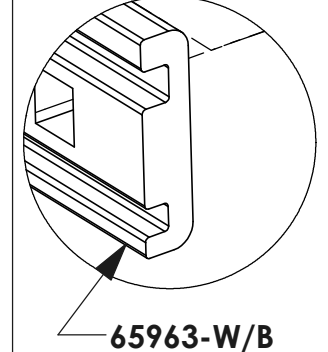

**STEP 3.2**  
**FULLY TIGHTEN**  
 FAS0838 &  
 FAS0861  
 (02 PLACES)  
 1/2" SOCKET

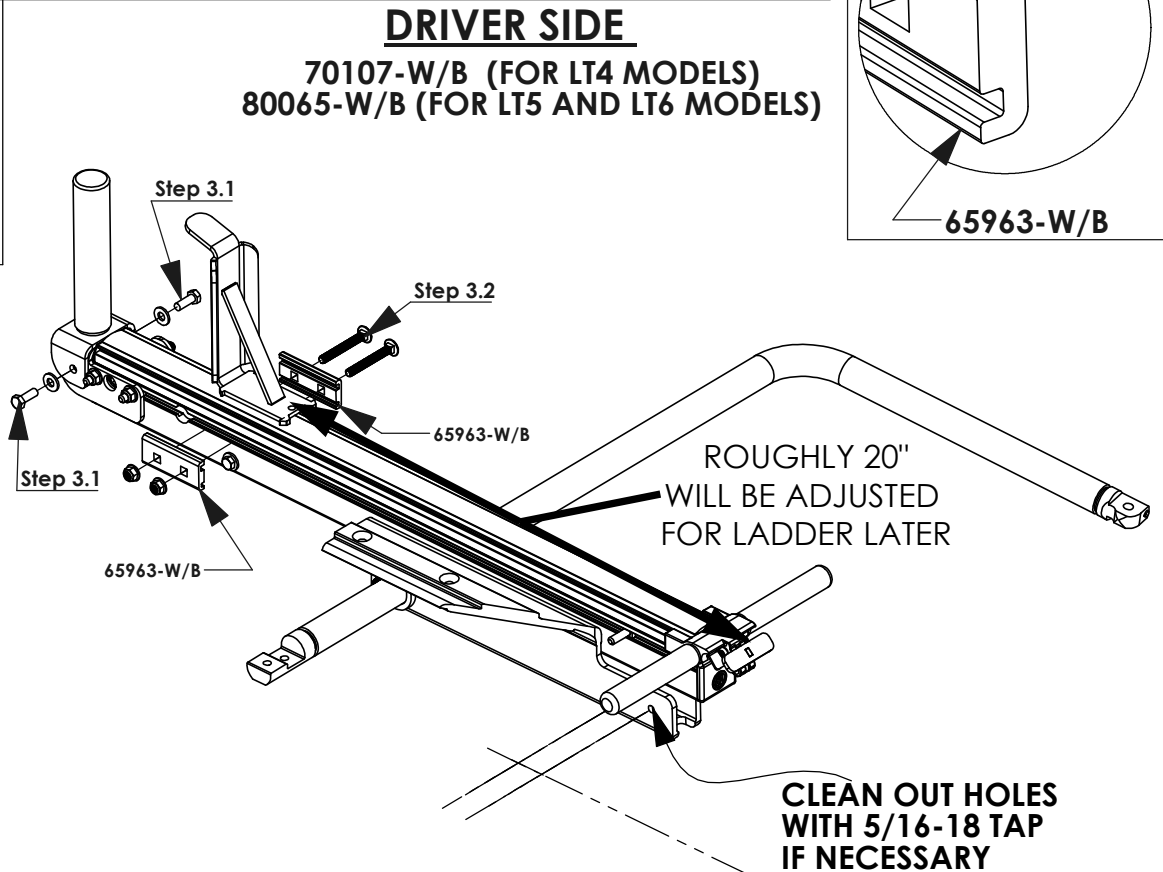

### DRIVER SIDE

70107-W/B (FOR LT4 MODELS)  
 80065-W/B (FOR LT5 AND LT6 MODELS)

# FRONT SUB-ASSEMBLY

## PASSENGER SIDE

68031-W/B

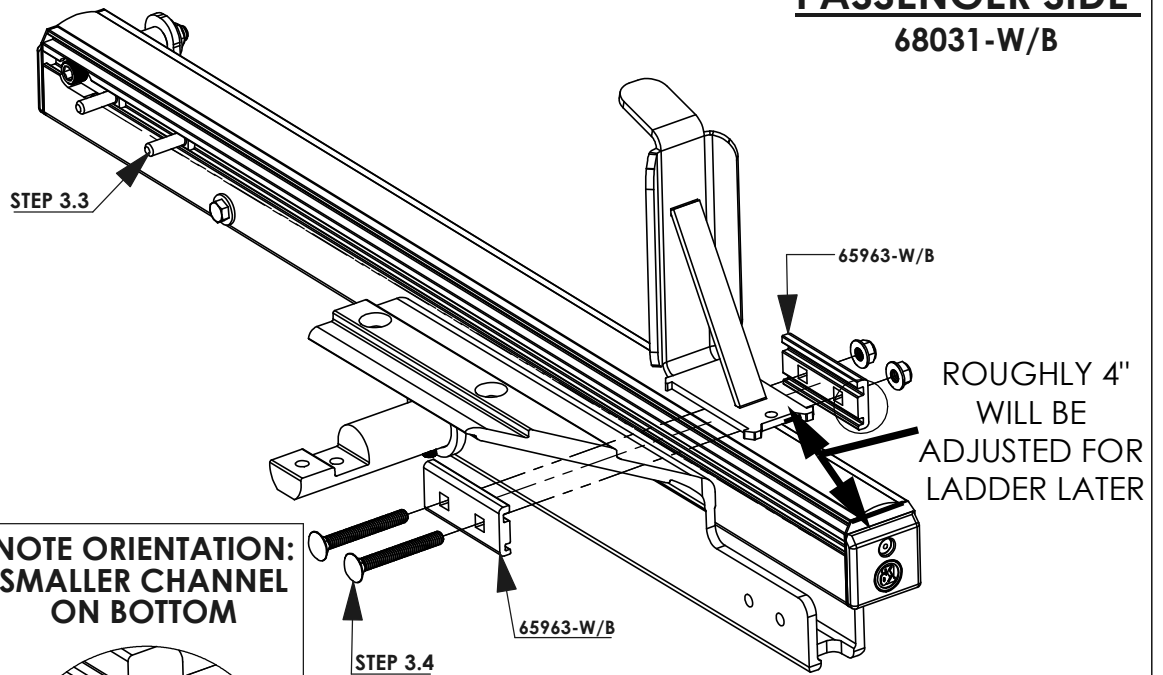

**STEP 3.3**  
**FULLY TIGHTEN**  
**FAS0838 &**  
**FAS0861**  
**(02 PLACES)**  
**1/2" SOCKET**

**NOTE ORIENTATION:**  
**SMALLER CHANNEL**  
**ON BOTTOM**

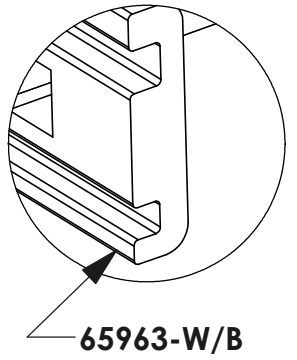

## DRIVER SIDE

68013-W/B

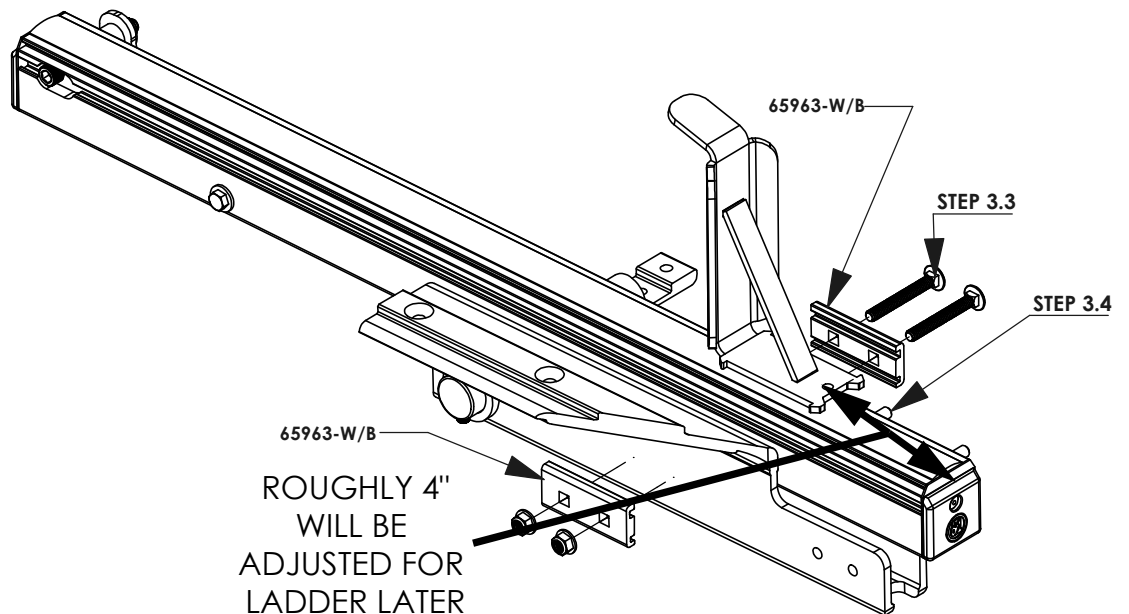

**STEP 3.4**  
**FAS0035**  
**SLIDE INTO SLOT**  
**(02 PLACES)**

**ROUGHLY 4"**  
**WILL BE**  
**ADJUSTED FOR**  
**LADDER LATER**



# REFERENCE INSTALLATION GUIDE 68895 TABLES 1-3 INSTALLATION OF A.1, A.2, B.1, & B.2 SHOULD BE COMPLETE BEFORE PROCEEDING TO STEP 4

## STEP 4 - INSTALL CARTRIDGES ON CROSSBOWS

**STEP 4.1**  
SLIDE 63490 INTO  
END OF  
CROSSBOWS

**C.1**

**STEP 4.2**  
LINE UP CORNERS  
WITH END OF  
CROSSBOW

**STEP 4.3**  
FULLY TIGHTEN  
(02) FAS0856,  
(02) FAS0857, &  
(02) 63490  
(02 PLACES PER  
SIDE)  
3/16" ALLEN

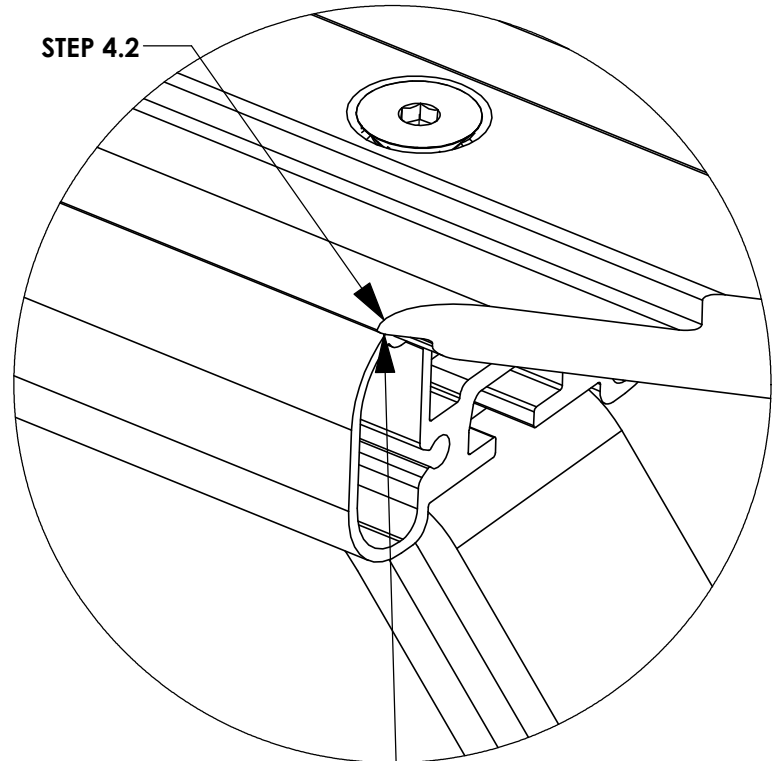
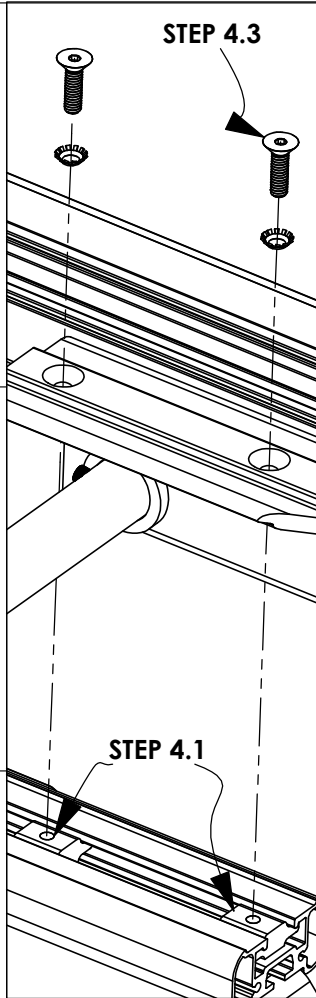

**LINE UP CORNERS!!**

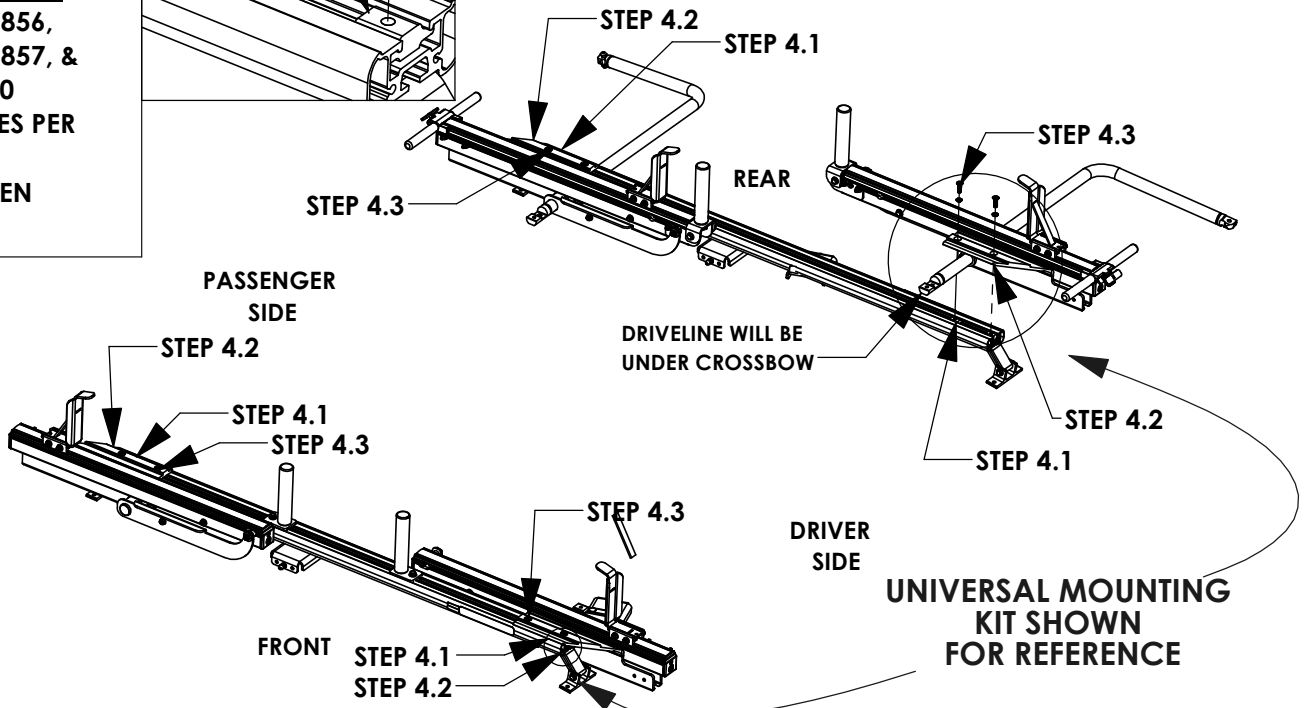

# STEP 5 - INSTALL DRIVELINE

**STEP 5.1**  
**FULLY TIGHTEN**  
**FAS0242, FAS0552**  
**& FAS0861**  
**(04 PLACES PER**  
**SIDE)**  
**1/2" WRENCH**  
**1/2" SOCKET**

**BEST PRACTICE:**  
**WHEN INSTALLING**  
**BOLTS OPEN RACK**  
**ROUGHLY 45**  
**DEGREES FOR**  
**EASIER ACCESS &**  
**INSTALLATION**

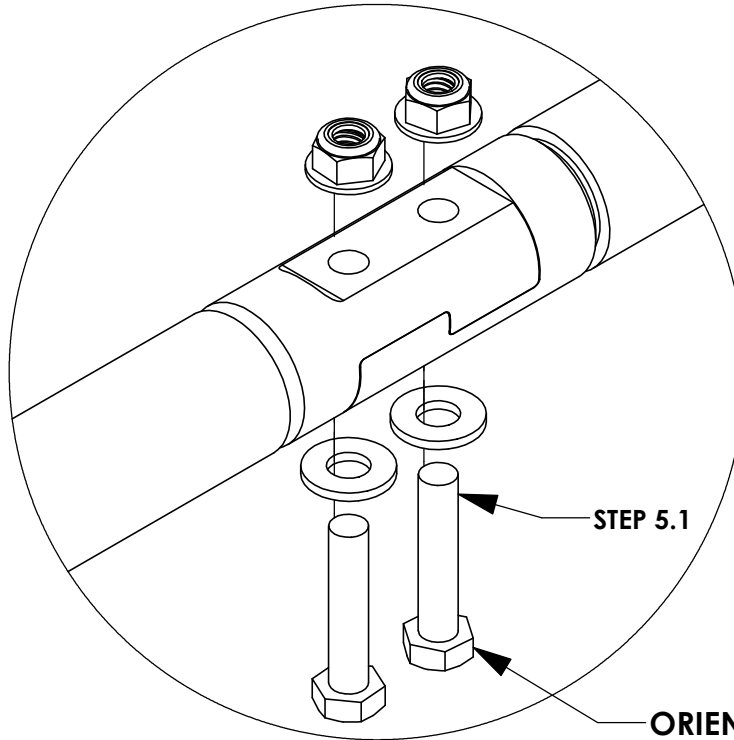

**ORIENTATION OF BOLTS IS UPWARDS FOR ASSEMBLY**

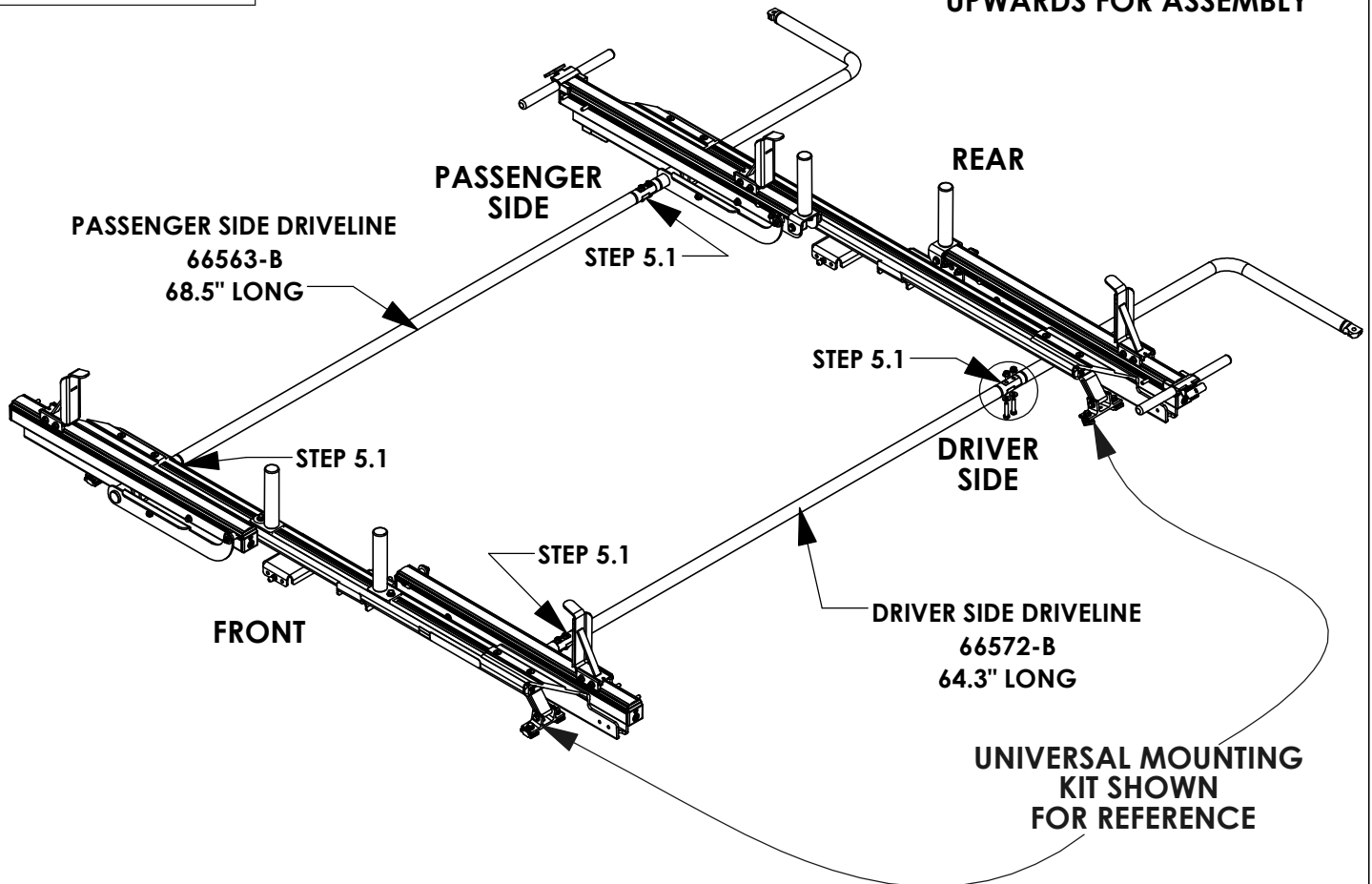

# STEP 6 - DEPLOY RACK & INSTALL DAMPERS AND DROP DOWN HANDLE

**Step 6.1**  
 ATTACH EXTENSION DAMPERS (48625) TO BALL STUDS.  
ORIENTATION OF DAMPER MATTERS!!!  
 (01 PLACE PER SIDE)

**Step 6.2**  
 ATTACH COMPRESSION DAMPERS (58239) TO BALL STUDS.  
ORIENTATION OF DAMPER MATTERS!!!  
 (01 PLACE PER SIDE)

**Step 6.3**  
 INSERT LOCKING PINS (34928-0) AFTER MOUNTING DAMPERS TO BALL STUDS  
 (04 PLACES PER SIDE)

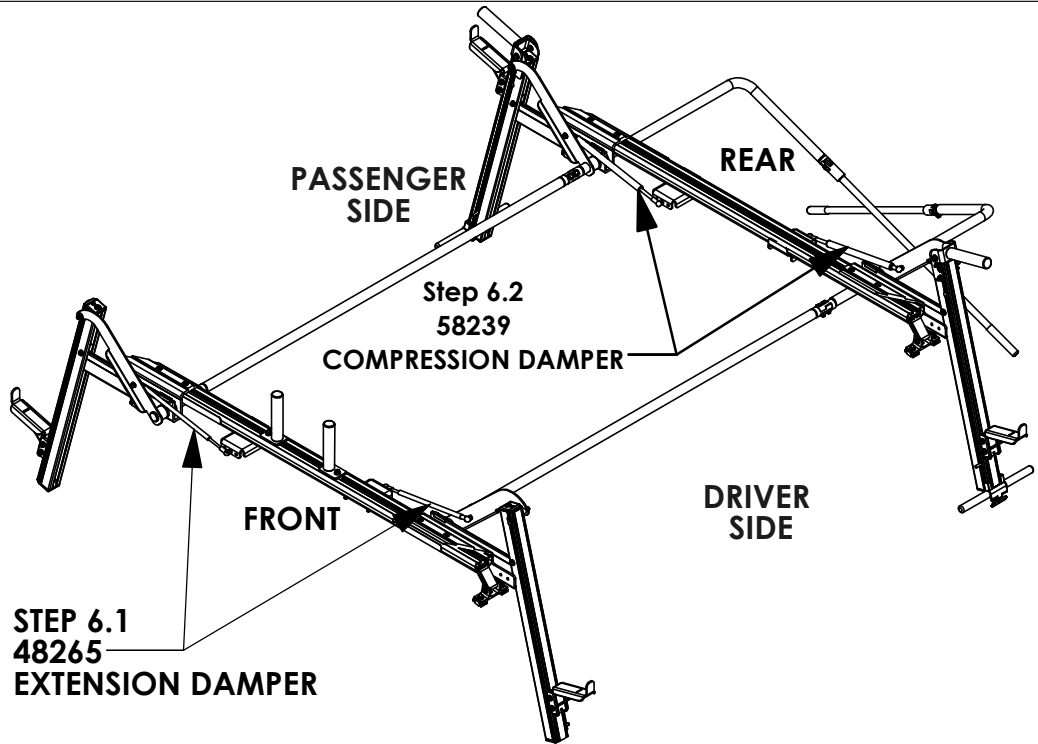

## ORIENTATION OF DAMPER MATTERS!!!!

LARGE CYLINDER OF DAMPER ATTACHES TO ARM  
 SMALL ROD END ATTACHES TO DAMPER BRACKET

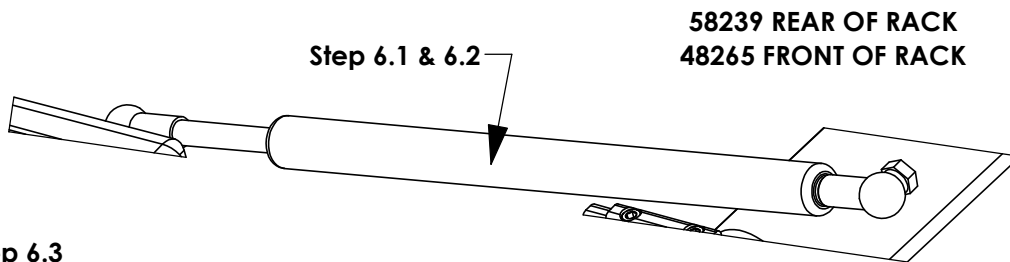

**Step 6.3**  
 34928-0

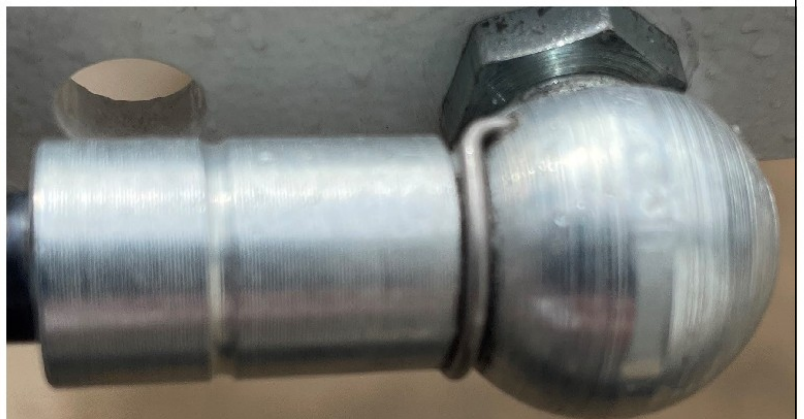
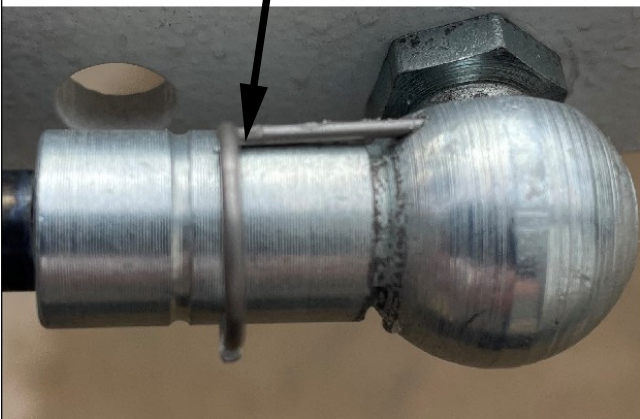

# STEP 7 - WHILE RACK DEPLOYED INSTALL O.S. BAR

Step 7.1  
**FULLY TIGHTEN**  
FAS0861  
(04 PLACES PER  
SIDE)  
1/2" SOCKET

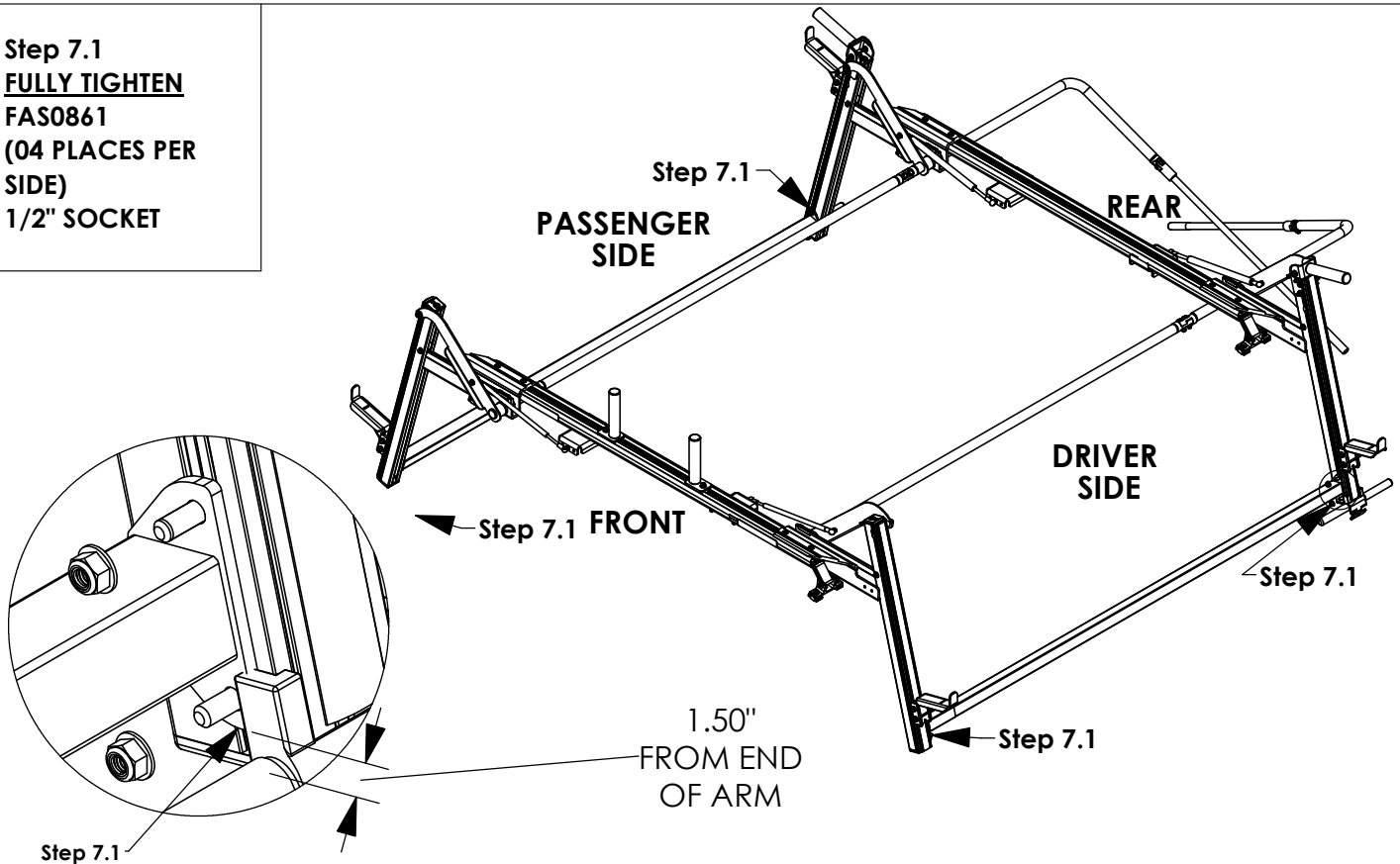

# STEP 8 - INSTALL DROP DOWN HANDLE

Step 8.1  
**FULLY TIGHTEN**  
FAS0819 & FAS0399  
(01 PLACES PER  
SIDE)  
7/32" ALLEN  
9/16" SOCKET

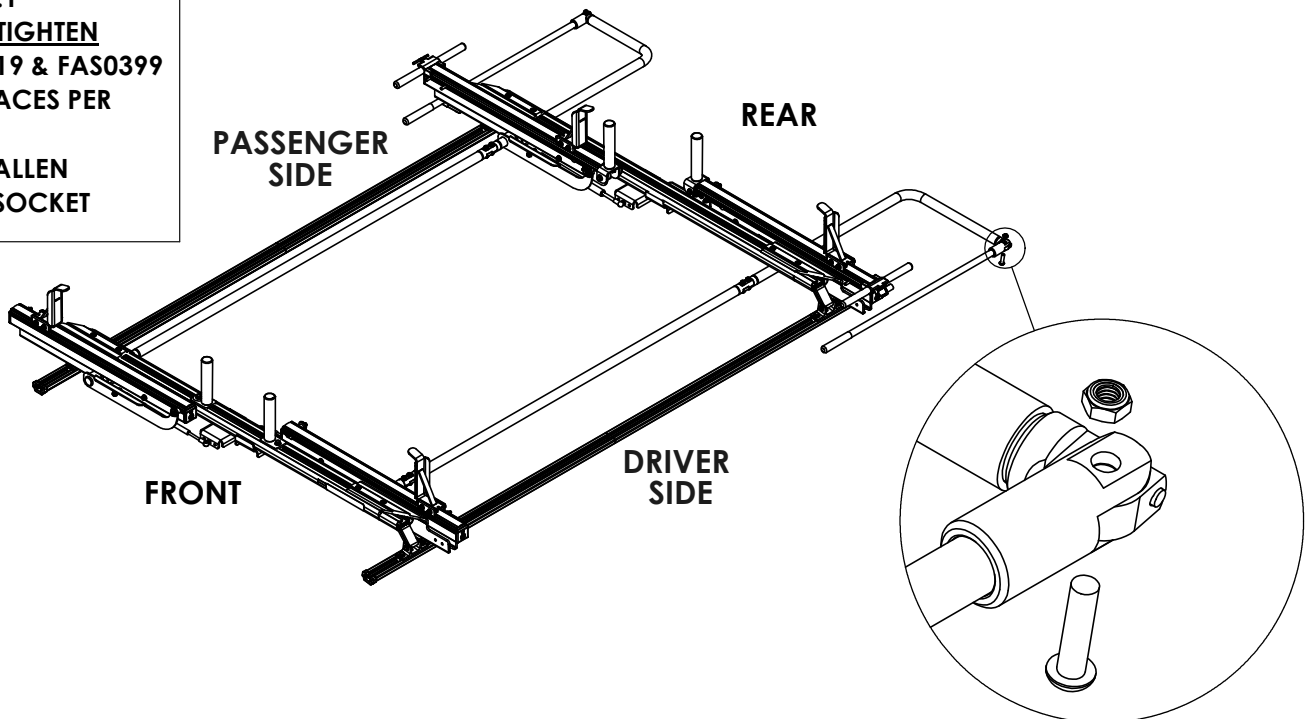

**MAKE SURE ALL FASTENERS ARE TIGHTENED!!! INSTALLATION IS COMPLETE**

# STEP 9 - INSTALL CROSSBOW END CAPS

Step 9.1  
**FULLY TIGHTEN**  
(02) FAS0473, 65961  
(02 PLACES PER SIDE)  
3/8" SOCKET

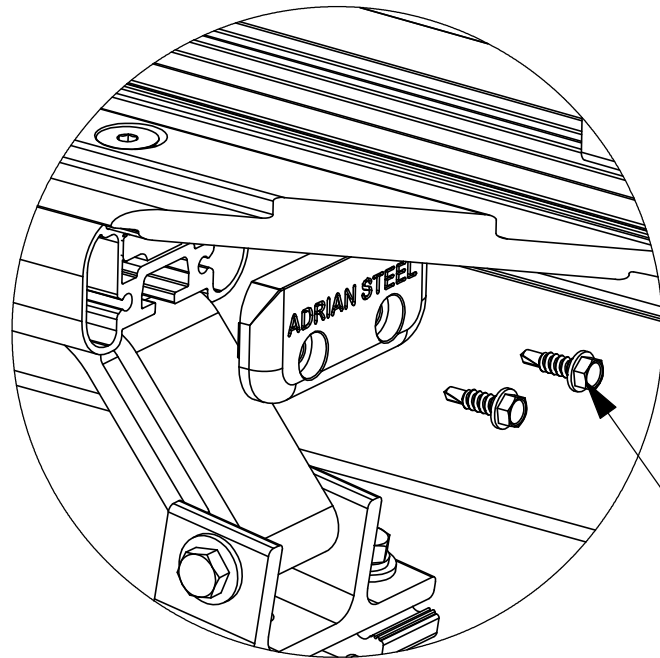

Step 9.1

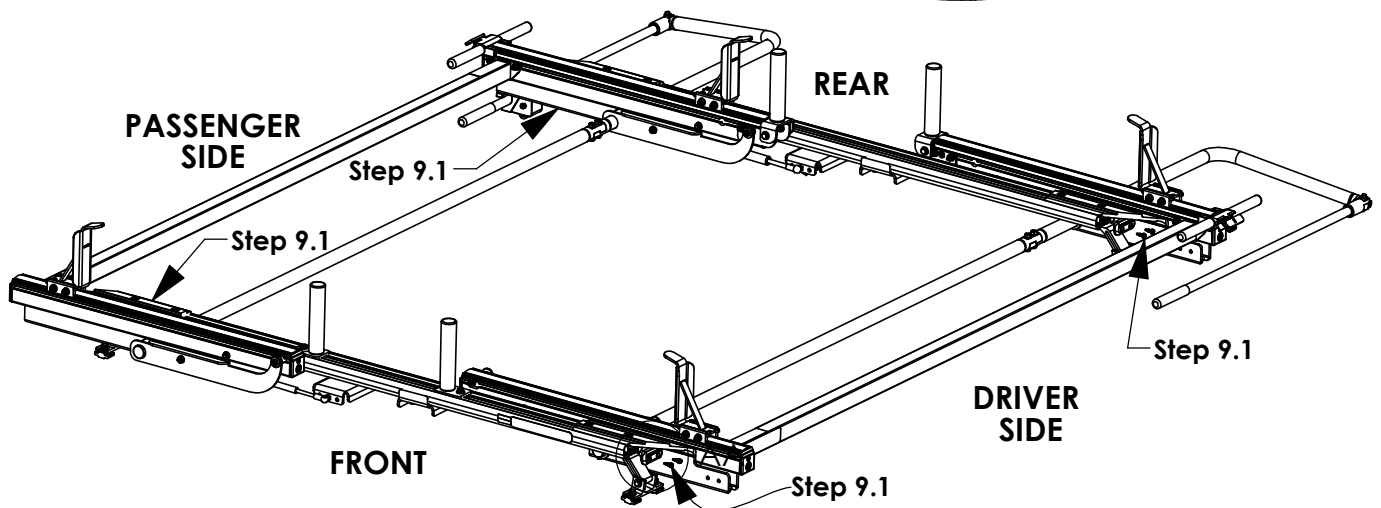

**MAKE SURE ALL FASTENERS ARE TIGHTENED!!! INSTALLATION IS COMPLETE**

**Step 10.1**  
**FULLY TIGHTEN**  
**FAS0819, FAS0399,**  
**(01 PLACE)**  
**7/32" ALLEN**  
**9/16" SOCKET**

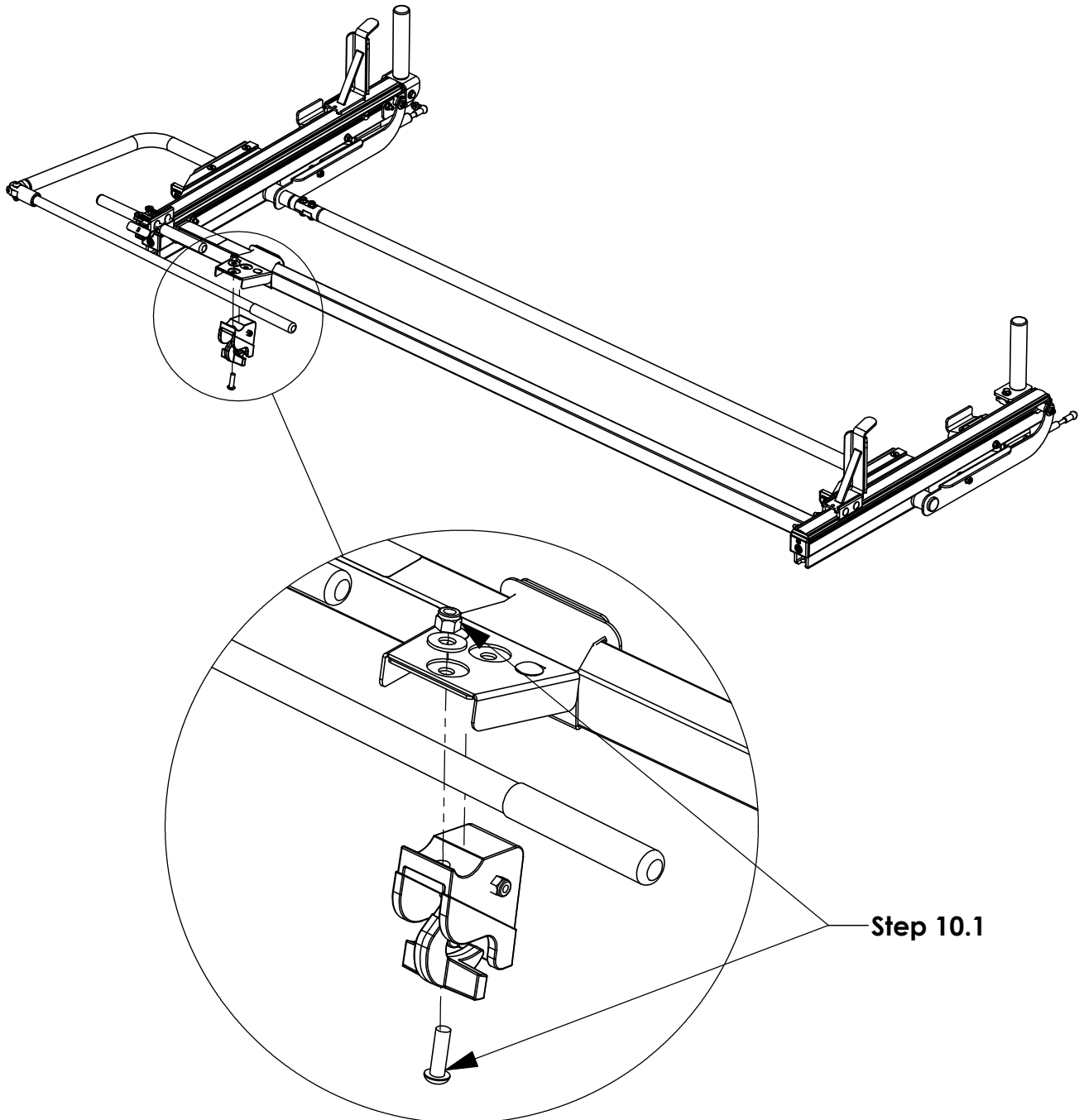

**Step 10.1**

**MAKE SURE ALL FASTENERS ARE TIGHTENED!!! INSTALLATION IS COMPLETE**

**ADRIAN STEEL®**

Cargo Management Solutions for Commercial Vehicles

# PROLIFT MAX DROP 4' PASSENGERS SIDE LOW TOPPER LADDER RACKS

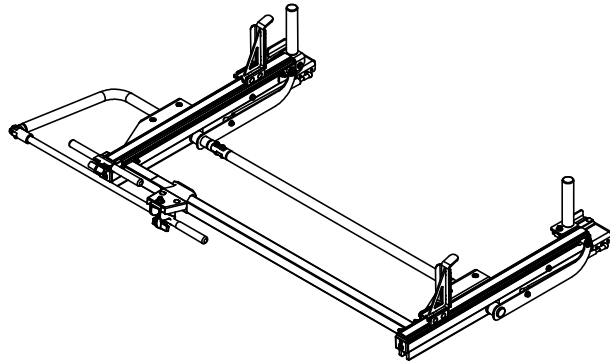
**PRODUCT WEIGHT****63.5 LBS****WIDTH X DEPTH X HEIGHT****82.00" X 32.00" X4.00"****CAPACITY****SINGLE LADDER****COLOR****WHITE/BLACK****CATALOG NUMBER****PLMDPSLT4W, PLMDPSLT4B****PRODUCT FEATURES**

ProLift™ Max Drop LOW Topper racks can be used on ADRIAN STEEL BIFF, LEER, UNICOVER and ARE truck toppers with bed lengths from 4'6" - 6'1" with appropriate rail kit, crossbow kit and mounting bracket kit. Use rail kits, crossbow kits, and mounting bracket kits listed in the table below to create new rack combinations. These racks include an attached handle.

The Max-Drop ProLift™ has a single function that lowers the ladder to a single set height and a secondary function that lowers the rear of the ladder even further to a safer more ergonomic height. Most similar to our previous DDLR drop-down series.

Unicover Toppers will use roof rail kits ending in UC (Ex. 4'6" Unicvoer topper would use RRKTOP55UC)

Ignore the roof rail kit when ordering racks for ASC BIFF toppers as they ship with pre-installed rails.

**Commercial Part Numbers**

Vehicle Platform	Bed Length	Bed Length (in)	Roof Rail Kit	Crossbow kit	Mounting Bracket Kit	Pro-Lift (Passenger Side)	Pro-Lift (Drivers Side)
Maverick	4'6"	54"	RRKTOP55/UC	2BARTOPW	MAVRMBK4W	PLSDPSLT4	PLSDDSLT4
All	4'10" - 5'6"	58" - 66"	RRKTOP58/UC	2BARTOPW	URMBK4W	PLSDPSLT4	PLSDDSLT4
All	5'7" - 6'1"	67"-73"	RRKTOP67/UC	2BARTOPW	URMBK4W	PLSDPSLT4	PLSDDSLT4

**NOTE:CROSSBAR KIT IS DIFFERENT FOR COMBO WITH GRIPLOCK. IN THIS CASE,USE 2BAR53W/B**

SEE PAGE 2 FOR APPLICATION NOTES, ACCESSORIES AND OTHER PRODUCTS THAT WORK WITH THIS UNIT.



# **PROLIFT MAX DROP 4' PASSENGERS SIDE LOW TOPPER LADDER RACKS**

**CATALOG NUMBER****PLMDPSLT4W, PLMDPSLT4B****PRODUCT APPLICATION**

**TOPPER PROLIFT LADDER RACKS ARE FOR USE ON PICKUP TRUCK BED TOPPERS, AVAILABLE IN 4 FT, 5 FT, AND 6 FT LENGTHS FOR ALL DIFFERENT SIZE TRUCK BEDS.**

**Reduce back and shoulder injuries while loading/unloading ladders by eliminating the need to climb on bumpers and tires to reach the cargo on the roof of your vehicle.**

**The ProLift™ uses unique, patent-pending, mechanical advantages, and high-performing spring assist struts to raise and lower ladders with an almost effortless pull.**

**ACCESSORIES THAT WILL WORK WITH THIS PRODUCT**

CATALOG NUMBER	DESCRIPTION (smart)
RRKTOP55	ROOF RAIL KIT, TOPPER, 55"
RRKTOP58	ROOF RAIL KIT, TOPPER, 58"
RRKTOP67	ROOF RAIL KIT, TOPPER, 67"
RRKTOP55UC	ROOF RAIL KIT, TOPPER, 55" UC
RRKTOP58UC	ROOF RAIL KIT, TOPPER, 58" UC
RRKTOP67UC	ROOF RAIL KIT, TOPPER, 67" UC
2BARTOPW / B	2BAR UTILITY RACK, TOP
2BAR53W / B	2BAR, CROSSBOW, 53"
URMBK4W / B	UTILITY, MNT BKT KT, RAIL
PLMDDSLT4W/B	PROLIFT, MAX, DS, LOW TOP, 4
GL-TOPDSW / B	GRIP-LOCK, TOP DS

**The information contained in this document is the sole property of ADRIAN STEEL COMPANY. ADRIAN STEEL COMPANY retains the right to modify and/or change the product of its design at any time with prior notification.**



## Mounting Bracket Kit, 4-Pack, White, Multiple Pickups

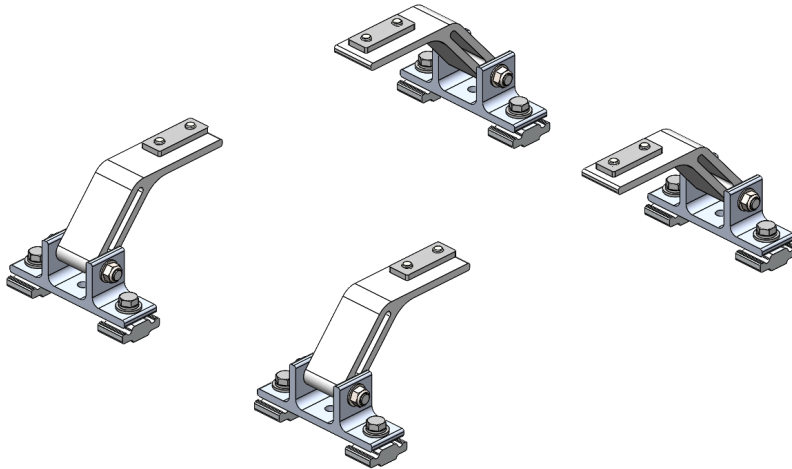

PRODUCT WEIGHT  
**4.0 LBS**

HEIGHT OFF ROOF  
**SEE TABLE BELOW**

CAPACITY  
**REFER TO OEM'S  
RECOMMENDED LOAD  
RATING**  
COLOR

**WHITE**

CATALOG NUMBER

**URMBK4W**

### PRODUCT FEATURES

**Aluminum mounting bracket kit for the PROFILE™ HD Utility, Grip-Lock, and/or ProLift ladder racks. Only works with the OEM specific, Adrian Steel supplied roof rail kit.**

**Utility and Grip-Lock racks are not recommended for medium or high roof vehicles!**

**Reference respective OEM specific roof rail kit for more detailed list of compatible accessories.**

**SEE PAGE 2 FOR APPLICATION NOTES AND ACCESSORIES, OTHER PRODUCTS THAT WORK WITH THIS UNIT.**

### PAGE 1 of 2

The information contained in this document is the sole property of ADRIAN STEEL COMPANY. ADRIAN STEEL COMPANY retains the right to modify and/or change the product of its design at any time without prior notification.



**CATALOG NUMBER URMBK4W**

**PRODUCT APPLICATION**

**This product is designed to work with OEM specific rail kit for HD Utility, Grip-Lock, and/or ProLift racks. HD Utility and Grip-Lock racks are not recommended for medium or high roof vehicles!**

**ACCESSORIES THAT WILL WORK WITH THIS PRODUCT**

CATALOG NUMBER	DESCRIPTION	CATALOG NUMBER	DESCRIPTION
RRKFT	Mounting Roof Rail Kit, Transit	RRKNVFSV	Mounting Roof Rail Kit, NV
RRKSP	Mounting Roof Rail Kit, Sprinter	RRKPM	Mounting Roof Rail Kit, ProMaster, 118" WB, 159" WB, 159" WB Extended
RRKPM136WB	Mounting Roof Rail Kit, ProMaster, 136" WB	RRKSBTOP	Mounting Roof Rail Kit, Multiple Pickups
RRKLBTOP	Mounting Roof Rail Kit, Multiple Pickups		

**Reference respective OEM specific roof rail kit for more detailed list of compatible accessories.**

INSTR. NUMBER : <b>66850</b>	PG: <b>1</b>	REV: <b>E</b>	ITEM NO.	PART NUMBER	DESCRIPTION	URMBK4W	URMBK2W
	PART NUMBER : <b>URMBK</b>		1	65123-W	UTILITY, FT MOUNT ARM, ST, W	4	2
PART DESC. : UTILITY, MNT BKT KT, RAIL			2	63852-W	UTILITY, MOUNTING BRKT, W	4	2

**-PART NUMBERS WITH "-W" SUFFIX ARE PAINTED WHITE  
-FOR BLACK MOUNTING KITS, REPLACE "-W" PARTS WITH "-B" PARTS**

**NOTE: THIS INSTRUCTION IS VALID FOR THE FOLLOWING KITS:**

- URMBK4W
- URMBK4B
- URMBK2W
- URMBK2B

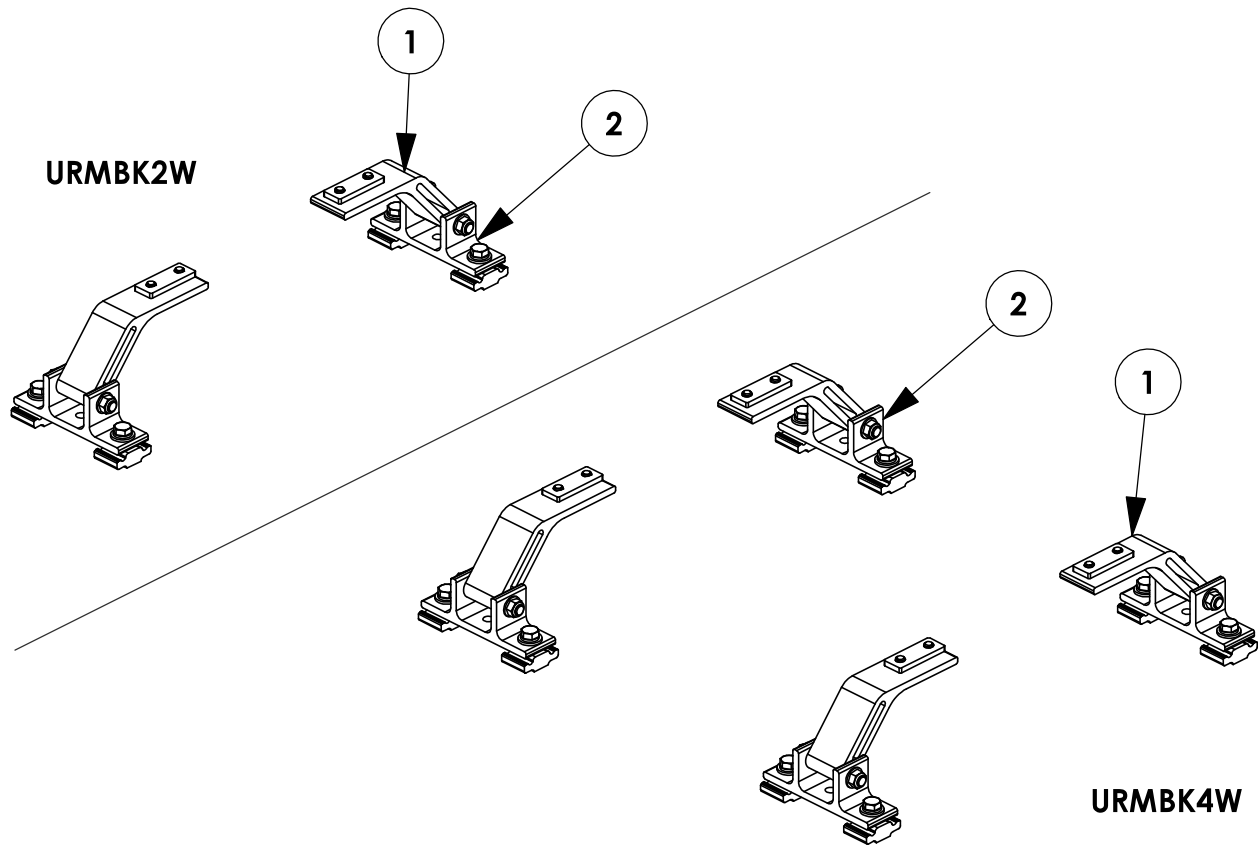

**TOOLS NEEDED:**

- DRIVE RATCHET
- IMPACT DRIVER
- 3/16" SOCKET
- 1/2" SOCKET
- 1/2" WRENCH
- TAPE MEASURE

**GET TO KNOW THE VEHICLE** - AT THE BEGINNING OF ANY INSTALLATION, CHECK THE LOCATION OF THE FUEL TANK, FUEL LINES, BRAKE LINES, HIGH VOLTAGE BATTERIES AND WIRING HARNESSSES TO AVOID INJURY OR PROPERTY DAMAGE FROM TOOL CONTACT.

**SEAL ALL EXTERIOR HOLES** - ALL INSTALLATION HOLES SHOULD BE SEALED WITH BUTYL TAPE OR SILICON TO PREVENT WATER AND EXHAUST GASES FROM ENTERING THE VEHICLE.

**CONTROL DRILL DEPTH** - TO AVOID DAMAGE TO THE VEHICLE, USE A DRILL STOP OR CLEARED STEP BIT WHEN DRILLING INSTALLATION HOLES.

**ALWAYS ADD PRIMER** - WHEN ADDING INSTALLATION HOLES BE SURE TO USE A SELF-ETCHING PRIMER TO PREVENT CORROSION, FASTENER FAILURE AND INJURY.

**MOUNTING POINTS MUST HAVE METAL-TO-METAL CONTACT** - USE PROVIDED MOUNTING SPACERS TO ACCOMMODATE FOR VEHICLE FEATURES, CARPET OR SUBFLOORS.

**PROVIDE CLEARANCE FOR SPACERS** - IF THE INSTALLATION VEHICLE CONTAINS A CARPET OR SUBFLOOR, USE A 1-3/16" DIAMETER CARPET CUTTER (P/N: 31183-0) AT ALL MOUNTING LOCATIONS TO OPEN UP ROOM FOR SPACERS.

**CHECK SPACER ORIENTATION** - BE SURE THAT THE INDENT IN THE SPACER COVERS THE PLUSNUT HEAD; THIS ENSURES THE MOST METAL-TO-METAL CONTACT AND REDUCES VIBRATION.

**PLUSNUT INSTALLATION** - A PLUSNUT GUN IS RECOMMENDED FOR PLUSNUT INSTALLATION FOR ITS PRODUCTION SPEED. HOWEVER, A PLUSNUT SETTING TOOL CAN ALSO BE USED (P/N: 22200-0).

**THRU-BOLT CLEARANCE** - WHEN USING A THRU-BOLT AT ANY MOUNTING LOCATION, BE SURE THAT YOUR HOLE HAS 1/16" CLEARANCE.

**FASTENERS AND HARDWARE USED**

**BAG REFERENCE: BAG66848**

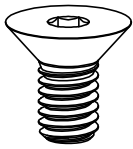

**FAS0858**  
**5/16-18X.63**  
**FHH SCREW**  
**QTY: 8**

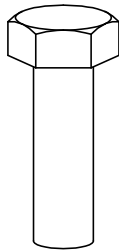

**FAS0597**  
**5/16-18X1.0 SS**  
**HH SCREW**  
**QTY: 8**

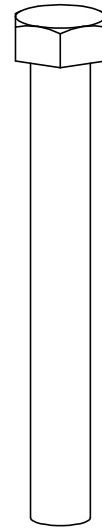

**FAS0243**  
**5/16-18X2.5 SS**  
**HH SCREW**  
**QTY: 4**



**FAS0857**  
**5/16 SS WASHER,**  
**LOCK EXT CS**  
**QTY: 8**



**FAS0588**  
**5/16 SS**  
**SPLIT WASHER**  
**QTY: 8**



**FAS0552**  
**5/16 SS**  
**FLAT WASHER**  
**QTY: 12**



**FAS0861**  
**5/16-18 SS**  
**HH FLG NUT**  
**QTY: 4**

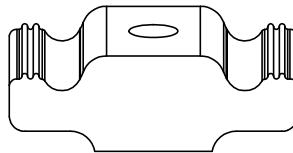

**63490**  
**RAIL SLIDE,**  
**1"**  
**QTY: 8**

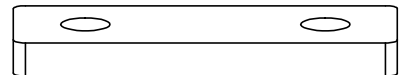

**68042**  
**PROFILE FOOT**  
**MOUNTING PLATE**  
**QTY: 4**

**PAGE INTENTIONALLY LEFT BLANK**

# STEP 1 - ASSEMBLE MOUNTING ARMS TO CROSSBOW



CHECK TABLE 1-3 IN INSTRUCTION 68895 FOR ADDITIONAL ACCESSORY SLIDE INSTALLATION BEFORE INSTALLING MOUNTING BRACKETS (ALL A.2 ITEMS SHOULD BE COMPLETELY ASSEMBLED FIRST!)

STEP 1.1  
LOOSELY ASSEMBLE  
UNTIL AFTER STEP 3  
(2) FAS0857, (2)  
FAS0858, 68042

(02 PLACES PER  
CROSSBOW)  
3/16" ALLEN

## ATTENTION!

IF INSTALLING A GRIP-LOCK ON A PICKUP TRUCK TOPPER, ASSEMBLE MOUNTING ARMS FACING OUTWARD FOR THAT SIDE OF THE RACK

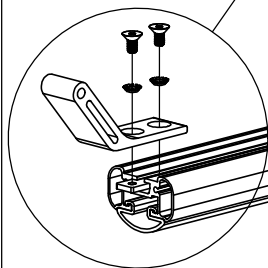
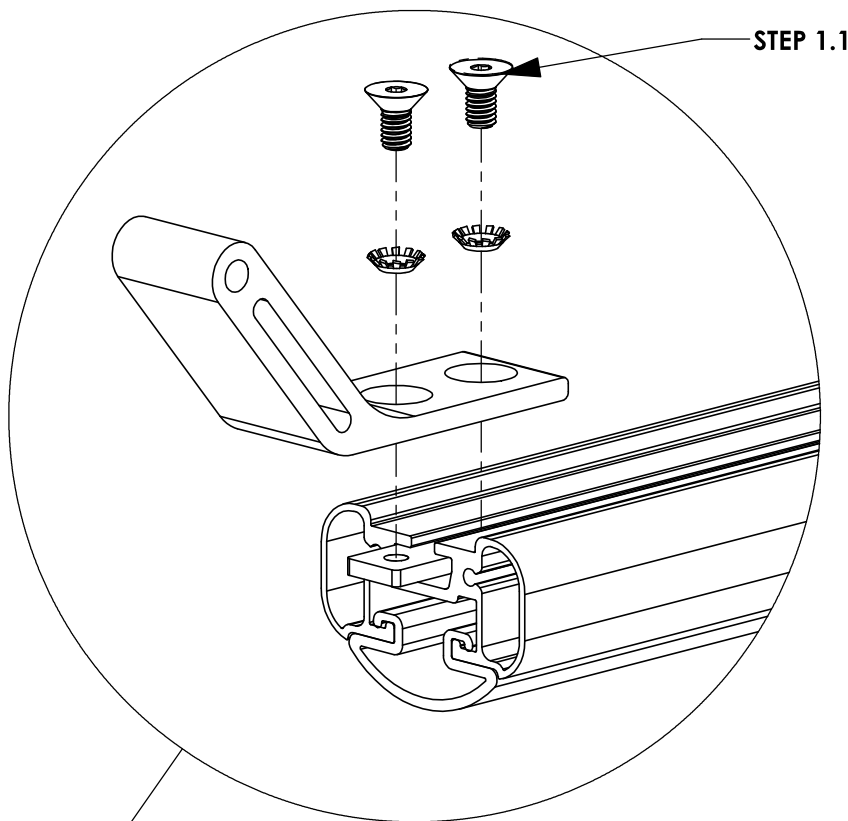

SLIDES AND FASTENERS WILL BE INCLUDED IN THEIR RESPECTIVE KITS. THESE SHOULD BE INSERTED PRIOR TO ASSEMBLING MOUNTING ARMS!

**STEP 2 - SECURE CROSSBOW**

**FULL SIZE VANS**

**CENTER CROSSBOW ON MOUNTING BRACKETS**

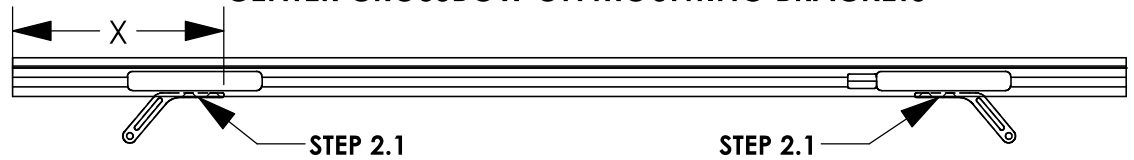

**STEP 2.1**  
**FULLY TIGHTEN**  
**FROM STEP 1.1**  
  
 (04 PLACES PER  
 CROSSBOW)  
 3/16" ALLEN

VEHICLE PLATFORM	DIMENSION "X" (in.) - 58" CROSSBOW	DIMENSION "X" (in.) - 68" CROSSBOW
FORD TRANSIT	6 5/8"	11 5/8"
RAM PROMASTER	6"	11"
NISSAN NV	4 7/8"	9 7/8"
MERCEDES SPRINTER (LOW ROOF)	4 5/8"	9 5/8"
MERCEDES SPRINTER (HIGH ROOF)	8 1/8"	13 1/8"

**DIMENSION WILL VARY BASED ON ROOF RAIL PLACEMENT ON TOPPER**

**PICKUP TRUCK TOPPERS**

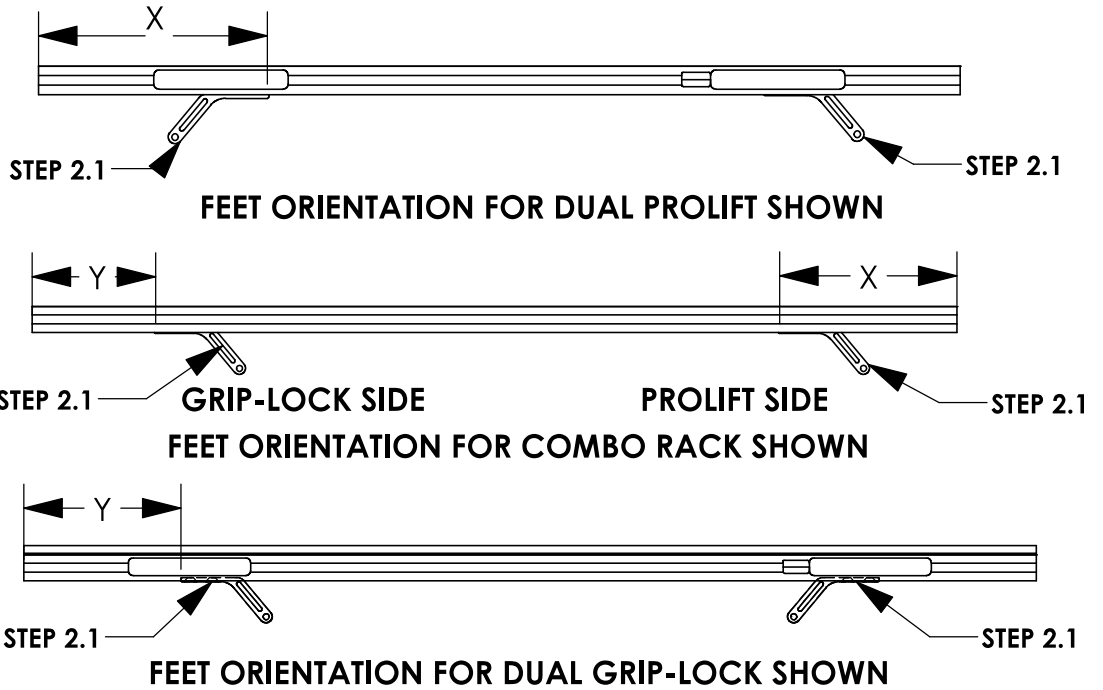

**MOUNTING FEET FOR GRIP LOCK SIDE OF COMBO RACK WILL FACE OUTWARD FROM ROOF CENTERLINE ON TOPPER**

CROSSBOW LENGTH	DIMENSION "X" (in.) - PROLIFT	DIMENSION "Y" (in.) - GRIPLOCK
48" (PROLIFT)	MINIMUM 10 1/8"	N/A
53" (COMBO)	MINIMUM 10 1/8"	MAX 7 1/8"
58" (GRIP-LOCK)	N/A	MAX 7 1/8"

**NOTE - THESE DIMENSIONS ARE APPROXIMATE AND WILL VARY SLIGHTLY WITH ANY TOLERANCE IN THE BUILD OF THE VEHICLE**

**STEP 3 - ASSEMBLE LOWER MOUNTING FOOT TO ROOF RAIL**

**STEP 3.1**  
**FULLY TIGHTEN**  
 FAS0597, FAS0552,  
 FAS0588, 63490 ON  
 REAR MOUNTING FEET  
 (02 PLACES PER  
 MOUNTING FOOT)  
 1/2" SOCKET

**STEP 3.2**  
**LEAVE LOOSE UNTIL**  
**AFTER STEP 4**  
 FAS0597, FAS0552,  
 FAS0588, 63490 ON  
 FRONT MOUNTING FEET  
 (02 PLACES PER  
 MOUNTING FOOT)  
 1/2" SOCKET

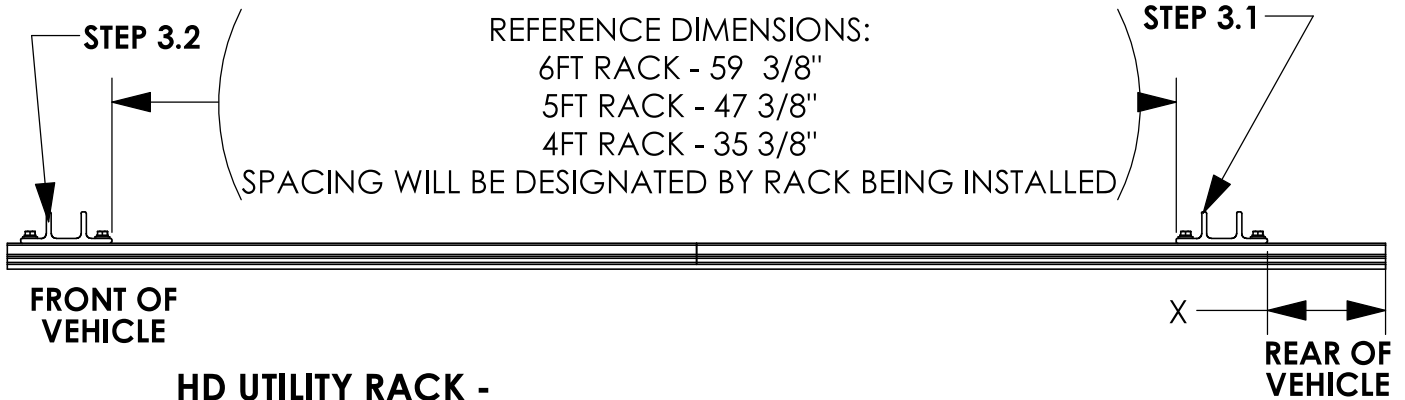
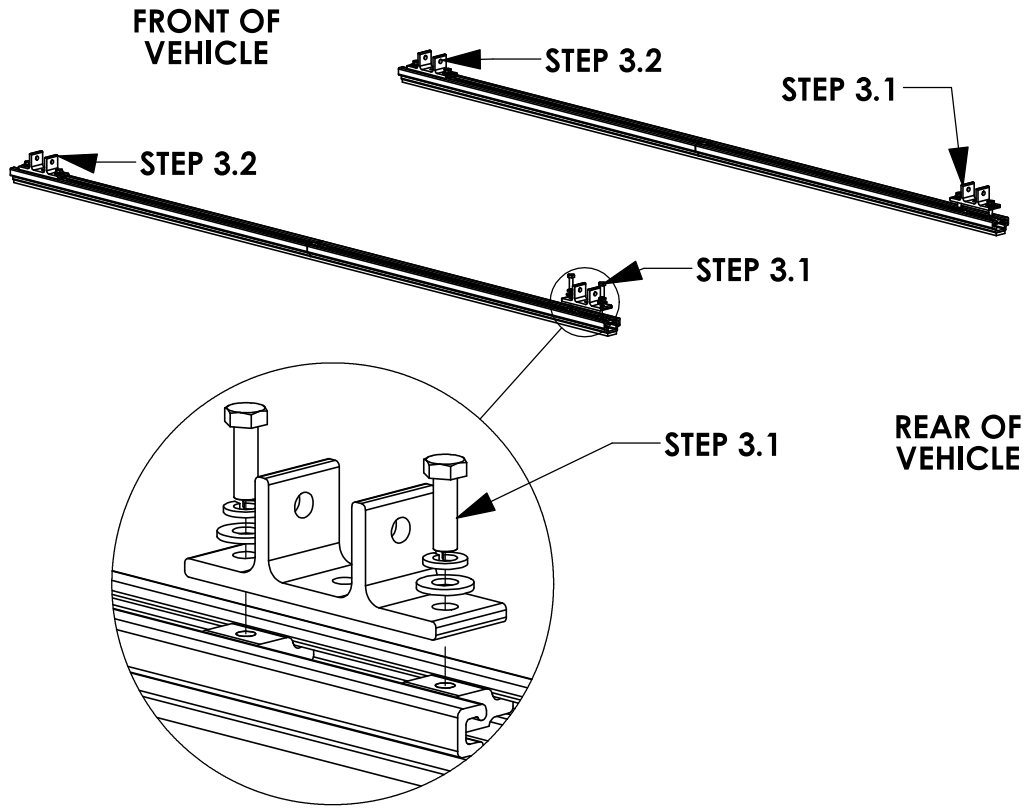

**HD UTILITY RACK -**

**REAR CROSSBOW - REARWARD AS POSSIBLE**  
**FRONT CROSSBOW- POSITION TO BEST FIT END USER'S PRODUCT**

FORD TRANSIT		RAM PROMASTER		MERCEDES SPRINTER	
ROOF HEIGHT/ WHEELBASE	POSITION X (IN)	ROOF HEIGHT/ WHEELBASE	POSITION X (IN)	ROOF HEIGHT/ WHEELBASE	POSITION X (IN)
LOW ROOF	7.5	LR 118	10	LR 144	10.5
MID ROOF	7.5	LR 136	10	HR 144	12.5
HIGH ROOF	7.5	HR 136	10	HR 170	12.5
HIGH ROOF EXT	7.5	HR 159/159 EXT	10	HR 170 EXT	12.5

# STEP 4 - ASSEMBLE MOUNTING BRACKETS TO MOUNTING ARMS



**BEFORE PROCEEDING WITH THIS STEP FINISH ASSEMBLING ACCESSORIES ONTO RACK. (IE GRIP LOCK, PROLIFT, ETC)**

### STEP 4.1

#### FULLY TIGHTEN

FAS0243, FAS0552,  
FAS0861

(02 PLACES PER  
CROSSBOW)

1/2" SOCKET  
1/2" WRENCH

### STEP 4.2

#### FULLY TIGHTEN

FAS0597, FAS0552,  
FAS0588, 63490 ON  
FRONT MOUNTING  
FEET

(02 PLACES PER  
MOUNTING FOOT)

1/2" SOCKET

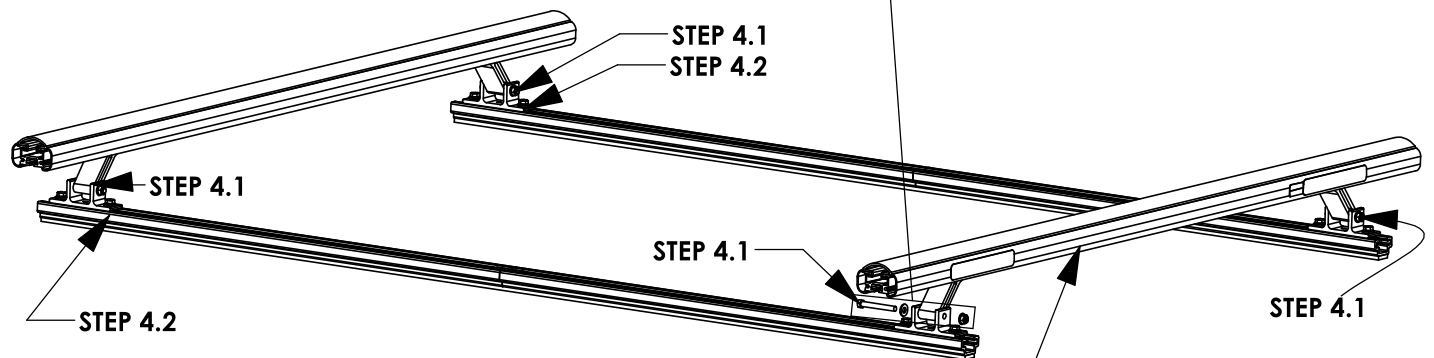
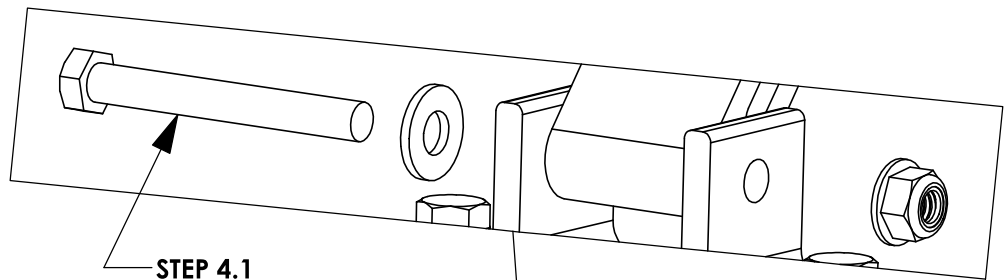

REFERENCE - NO ACCESSORIES SHOWN

**STEP 5 - ADJUST MOUNTING BRACKET LOCATION IF NECESSARY**

**CROSSBOW POSITIONING NOTES:**

**HD UTILITY RACK -**

REAR CROSSBOW - REARWARD AS POSSIBLE  
 FRONT CROSSBOW- POSITION TO BEST FIT END USER'S PRODUCT

**GRIP LOCK/PROLIFT LADDER RACKS -**

1/2" FROM END OF RAIL UNLESS OTHERWISE STATED IN RESPECTIVE INSTRUCTION FOR CROSSBOW PLACEMENT.

**6' ARE TOPPER / 8' LEER TOPPER**

**A** OPTIMAL RAIL KIT POSITION:  
 TOPPER ROOF RAIL KIT END TO BE  
 A-DIM FROM BLACK TOPPER TRIM

**B** UTILITY MOUNTING BRACKET:  
 REAR MOUNTING BRACKETS WILL  
 BE B-DIM FROM THE END OF THE  
 ROOF RAIL KIT

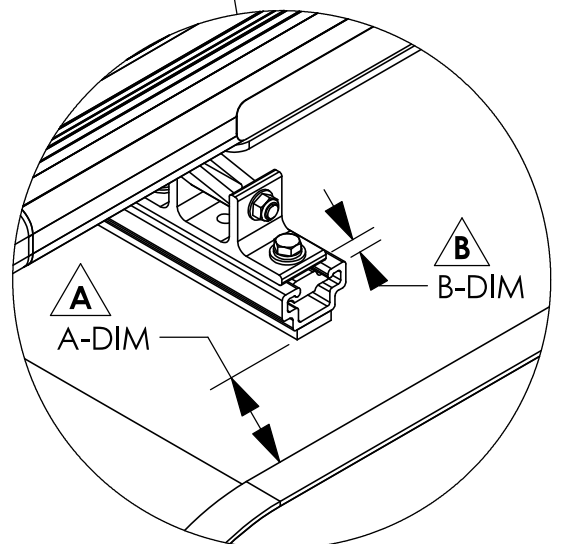
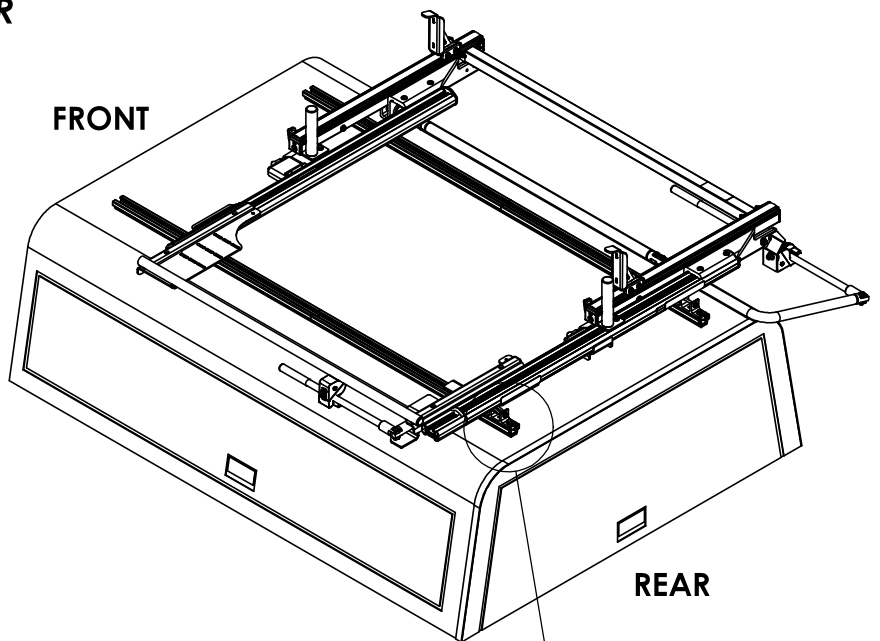

TOPPER/ DIMENSION	6' ARE TOPPER	8' LEER TOPPER
A-DIM	3.00"	1.00"
B-DIM	0.50"	0.50"

**NOTE:**  
 IF RAILS HAVE BEEN PREVOIUSLY INSTALLED, LOOSEN TOPPER RAIL BRACKET RAIL SLIDES  
 AND ADJUST TO MEET DESIRED POSITIONING

**INSTALLATION IS COMPLETE!! MAKE SURE ALL FASTENERS ARE TIGHTENED**



## 2-Crossbar Kit, 48", White, Multiple Pickups



PRODUCT WEIGHT  
**13.4 LBS**

CROSSBOW LENGTH X  
HEIGHT

**49" x 2"**

CAPACITY

**REFER TO OEM'S  
RECOMMENDED LOAD  
RATING**

COLOR

**WHITE**

CATALOG NUMBER

**2BARTOPW**

### PRODUCT FEATURES

Aluminum base 2-crossbow kit for PROFILE™ HD Utility, Grip-Lock, ProLift, or combo ladder racks. Works with all ARE and Leer toppers for all cab styles and bed lengths. Works with and without OEM specific rail kit and generic mounting bracket kits.

Additional crossbows and optional uprights, conduit kits, and rear rollers available.

Utility and grip lock ladder racks are not recommended for medium and high roof vehicles!

Please refer to OEM specific mounting kit or rail kit for additional information on compatible accessories.

# INSTALLATION GUIDE FOR PROFILE™ SERIES LADDER RACKS

INSTRUCTION #:  
**68895**

REV:  
**C**



THIS INSTRUCTION PROVIDES A GENERAL GUIDE OF INSTALLATION SEQUENCE FOR ALL PROFILE™ SERIES LADDER RACKS. PLEASE ENSURE ALL ACCESSORIES ARE INSTALLED PER TYPE OF RACK BEFORE PROCEEDING TO NEXT PAGE.

REFERENCE THIS INSTRUCTION THROUGHOUT THE ENTIRETY OF YOUR INSTALL TO PREVENT ACCESSORIES BEING INSTALLED INCORRECTLY/OUT OF SEQUENCE!

*STEPS 2T - 8T ON PAGE 3 IS THE RECOMMENDED ASSEMBLY SEQUENCE FOR A FULL TABLE ASSEMBLY BEFORE INSTALLING ON THE ROOF OF THE VEHICLE.*

*STEPS 2R - 8R ON PAGE 4 IS AN ALTERNATE ASSEMBLY SEQUENCE TO INSTALL THE RACK ON THE VEHICLE ROOF AS IT IS BUILT.*

PLEASE SELECT THE ASSEMBLY SEQUENCE THAT BEST WORKS FOR YOU!

## ASSEMBLY STEPS:

**STEP 1A.** *SUB-ASSEMBLE EACH CROSSBOW WITH DESIRED ACCESSORIES FOR SECTIONS A.1 & A.2.*

*INSTRUCTIONS FOR EACH KIT CAN BE FOUND IN THEIR RESPECTIVE CARTON!*

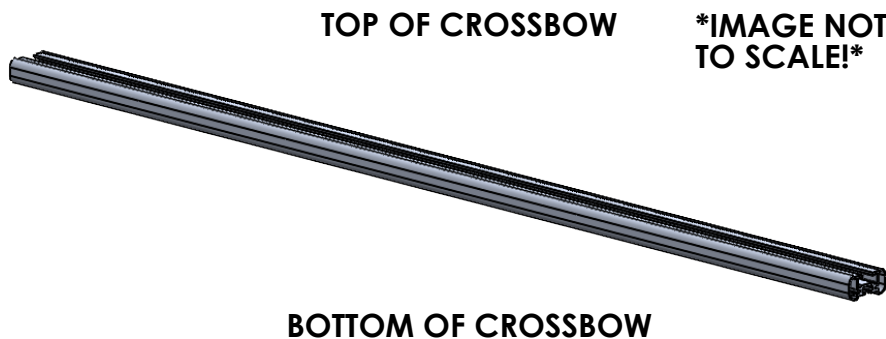

## TABLE 1

### TOP OF CROSSBOW

#### COMPONENTS TO INSTALL

A.1	HD UTILITY	- CONDUIT KIT OR BEACON
	Grip-Lock	- CONDUIT KIT OR BEACON
	ProLift	- CONDUIT KIT OR BEACON

### BOTTOM OF CROSSBOW

#### COMPONENTS TO INSTALL

A.2	HD UTILITY	- LADDER STOP, STROBE BRACKET, AND/OR REAR ROLLER
	Grip-Lock	- Grip-Lock SUB-ASSEMBLY
	ProLift	- DAMPER BRACKET

**STEP 1B. SUB-ASSEMBLE EACH CROSSBOW WITH DESIRED ACCESSORIES FOR SECTIONS B.1 & B.2. INSTRUCTIONS FOR EACH KIT CAN BE FOUND IN THEIR RESPECTIVE CARTON!**

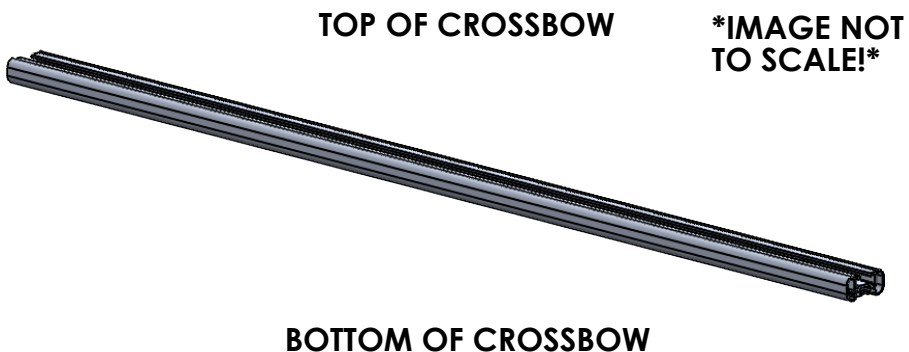

**ALTER WEAR STRIP AND INSTALL ON CROSSBOW (IF APPLICABLE)! REFERENCE TABLE 3 BELOW FOR WEAR STRIP ALTERATION INSTRUCTIONS!**

**TABLE 3**

ADDED ACCESSORIES	ALTERATION FOR WEAR STRIP
4" UPRIGHT***	REMOVE 2" FROM END OF WEAR STRIP
4" PVC CONDUIT KIT	REMOVE 7.25" FROM CENTER OF WEAR STRIP
6" PVC CONDUIT KIT	REMOVE 9.50" FROM CENTER OF WEAR STRIP
ALUMINUM BOX CONDUIT KIT	REMOVE 13.25" FROM CENTER OF WEAR STRIP
BEACON	REMOVE 4" FROM CENTER OF WEAR STRIP
ProLift (SINGLE SIDE)	CUT WEAR STRIP IN HALF, DO NOT INSTALL ON ProLift SIDE
ProLift (DUAL SIDE)	DO NOT INSTALL WEAR STRIP

**TABLE 2**

TOP OF CROSSBOW		
COMPONENTS TO INSTALL		
<b>B.1</b>	HD UTILITY	- WEAR STRIP (MODIFY IF NECESSARY, TABLE 3)
	Grip-Lock	- WEAR STRIP (MODIFY IF NECESSARY, TABLE 3)
	ProLift	- INNER STOP POST
BOTTOM OF CROSSBOW		
COMPONENTS TO INSTALL		
<b>B.2</b>	HD UTILITY	- MOUNTING BRACKETS
	Grip-Lock	- MOUNTING BRACKETS
	ProLift	- MOUNTING BRACKETS

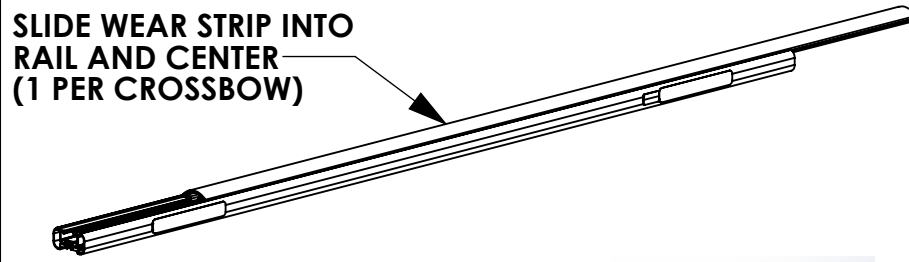

**SLIDE ONE SIDE OF WEAR STRIP INTO CROSSBOW, THEN ROLL OTHER SIDE TO SNAP STRIP INTO PLACE**

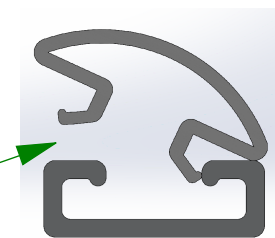

**STEP 1C SUB-ASSEMBLE EACH CROSSBOW WITH DESIRED ACCESSORIES FOR SECTIONS C.1 & C.2**



**TABLE 4**

TOP OF CROSSBOW		
COMPONENTS TO INSTALL		
C.1	HD UTILITY	- 4" UPRIGHT
	Grip-Lock	- N/A
	ProLift	- SLIDES FOR BASE EXTRUSION
BOTTOM OF CROSSBOW		
COMPONENTS TO INSTALL		
C.2	HD UTILITY	- UPRIGHTS (6", 9", RATCHET)
	Grip-Lock	- STROBES
	ProLift	- STROBES

**ASSEMBLY STEPS (FULL BENCH ASSEMBLY):**

- 2T. ADD DRIVELINES (IF INSTALLING ProLift)
- 3T. ADD HANDLES (IF INSTALLING Grip-Lock OR ProLift) AND DAMPERS (IF INSTALLING ProLift)
- 4T. ADD OUTER SUPPORT BARS (IF INSTALLING Grip-Lock OR ProLift)
- 5T. ADD STEP LADDER KIT (Grip-Lock OR ProLift ONLY!)

**6T. ASSEMBLE ENDS CAPS TO CROSSBOW**

USED FOR HD UTILITY & Grip-Lock RACKS

LOCATED IN CROSSBOW KIT

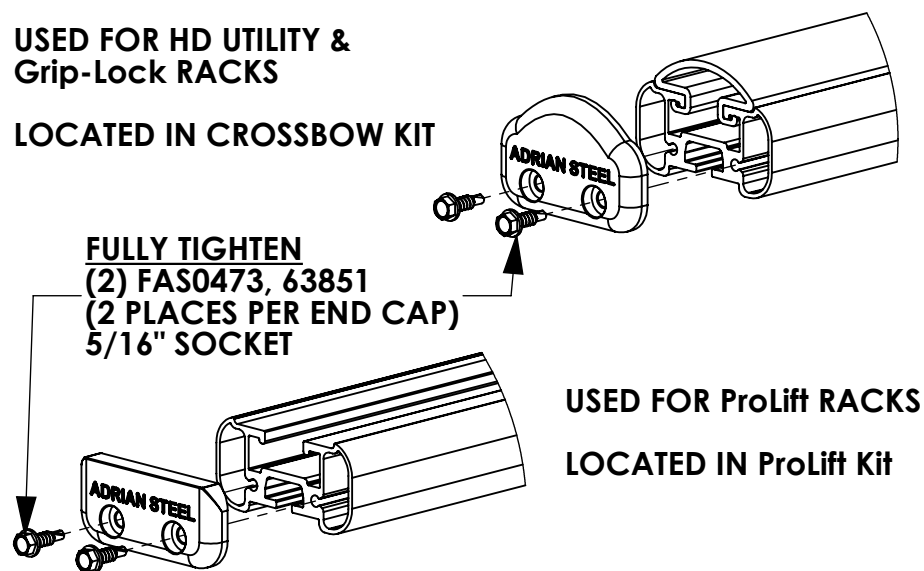

USED FOR ProLift RACKS  
LOCATED IN ProLift Kit

**7T. INSTALL ROOF RAIL KIT ON VEHICLE ROOF OR BOTTOM MOUNTING BRACKETS**

(ROOF RAIL KIT REQUIRED FOR Grip-Lock & ProLift OPTIONAL FOR HD UTILITY, NOT NEEDED FOR GM LADDER RACKS)

**8T. MOUNT CROSSBOW SUB-ASSEMBLIES FROM STEP 1 TO VEHICLE/MOUNTING BRACKET, OR ROOF RAIL (LOOSE INSTALL)**

**ALTERNATE ASSEMBLY METHOD!**  
**(ASSEMBLE ON VEHICLE ROOF):**

2R. INSTALL ROOF RAIL KIT ON VEHICLE ROOF OR BOTTOM MOUNTING BRACKETS

(ROOF RAIL KIT REQUIRED FOR Grip-Lock & ProLift, OPTIONAL FOR HD UTILITY, NOT NEEDED FOR GM LADDER RACKS)

3R. MOUNT CROSSBOW SUB-ASSEMBLIES FROM STEP 1 TO VEHICLE/MOUNTING BRACKET, OR ROOF RAIL (LOOSE INSTALL)

4R. ADD DRIVELINES (IF INSTALLING ProLift)

5R. ADD HANDLES (IF INSTALLING Grip-Lock OR ProLift) AND DAMPERS (IF INSTALLING ProLift)

6R. ADD OUTER SUPPORT BARS (IF INSTALLING Grip-Lock OR ProLift)

7R. ADD STEP LADDER KIT (Grip-Lock OR ProLift ONLY!)

8R. ASSEMBLE END CAPS TO CROSSBOW

USED FOR HD UTILITY & Grip-Lock RACKS

LOCATED IN CROSSBOW KIT

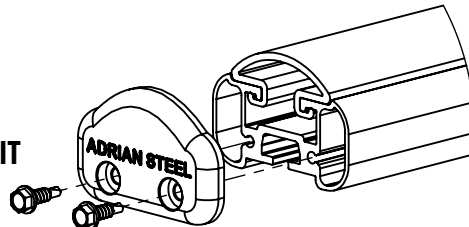

**FULLY TIGHTEN**  
**(2) FAS0473, 63851**  
**(2 PLACES PER END CAP)**  
**5/16" SOCKET**

USED FOR ProLift RACKS  
LOCATED IN ProLift Kit

