

FORD TRANSIT LOW-ROOF PARTITION

PRODUCT WEIGHT

58 LBS

WIDTH x DEPTH x HEIGHT

67.3" x 7" x 55.7"

CAPACITY

N/A

COLOR

BLACK

CATALOG NUMBER

PARFTL2

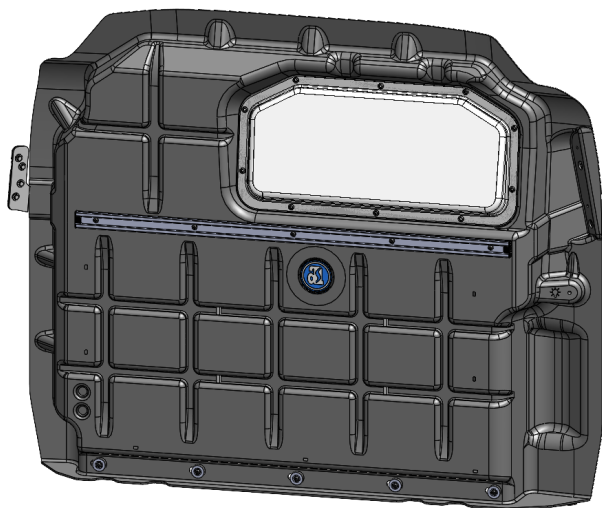

PRODUCT FEATURES

Composite partition for FORD TRANSIT LOW ROOF provides a semi-sealed solution for separating the cab area from the cargo area. The composite partition features a full perimeter bulb seal that seals off the majority of the airflow from the cab area to the cargo area. This feature provides better climate control for the cab area and reduces noise transfer from the cargo area to the cab area. This product is "No-Drill" and is compatible with the E-Transit model lineup.

Driver Comfort Details

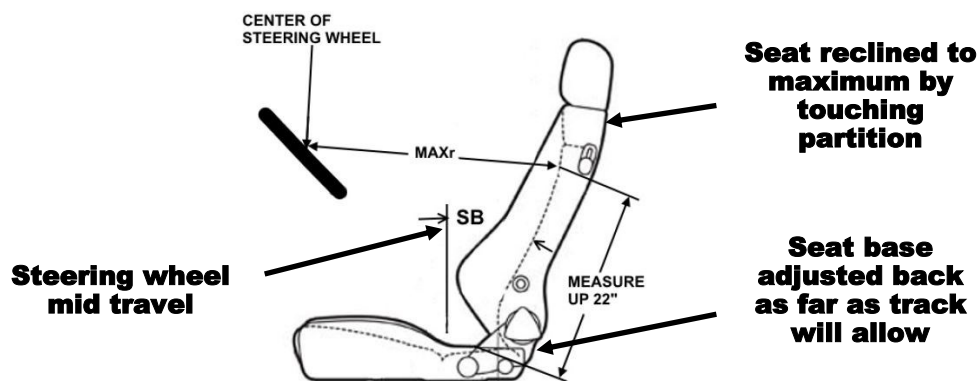

	DESCRIPTION	DIMENSION
SB	SEAT BACK ANGLE	12 degrees
MAXr	MAXIMUM DRIVER REACH	31"

SEE PAGE 2 FOR APPLICATION NOTES AND ACCESSORIES, OTHER PRODUCTS THAT WORK WITH THIS UNIT.

Accessory Chart

	Cargo Side			Cab Side		
	Base Partition BAGRKA1 REQUIRED (1 BAGRKA1 will allow for one accessory to be added)	PARHDW Fastener Kit Allow accessories to be added directly mounted to partition	PARFTCRG (mounting kit cargo side)	Base Partition 1/4" nuts and bolts REQUIRED	PARHDW Fastener Kit Allow accessories to be added directly mounted to partition	PARFTCAB (mounting kit cab side)
Available Accessories	-	-	-	-	-	-
PA7: Reflector kit	X	X	X	X	X	X
PA8: Fire ext.	X	X	X	X	X	X
PA9: First aid tray	X	X	X	X	X	X
PA10: Practice holder			X			X
PA11: Cab file			X	X		X
PA11NL: Catalog box			X	X		X
TA1: Four hook bar			X			X
CCD6: Center console 6"						X
TDC6: Tech desk 6"						X
TH30: 30lb tank holder			X			
TH50: 50lb tank holder			X			
UH50RM1: Rail mount kit			X			X
UH10: 1" hook			X			
UH25: 2.5" hook			X			
UH25CP-G: 2.5' hook comp			X			
UH50: 5" hook	X		X			

PARFTCRG (shown in yellow)
Cargo side hardware mounting kit
installed

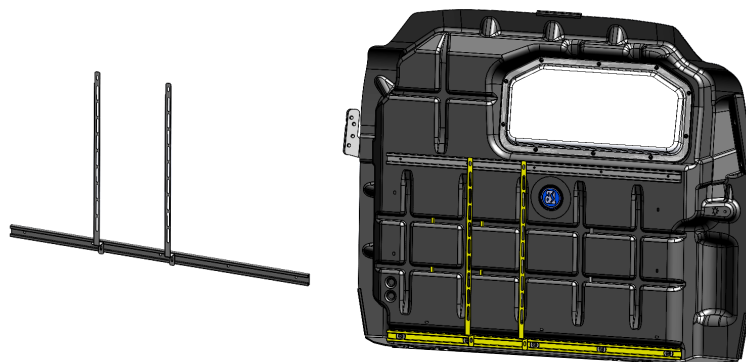

PARFTCAB (shown below in yellow)
Cab side hardware mounting kit installed

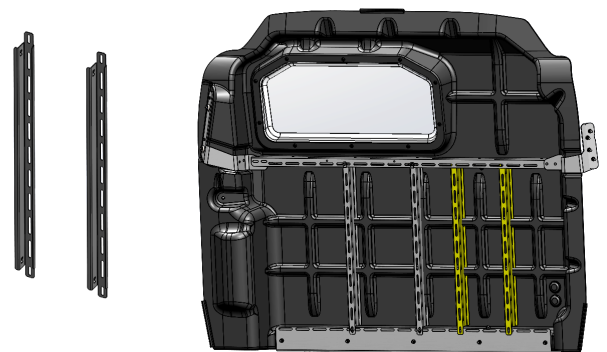

PARHDW Fastener Kit

Fastener kits allow for installation of smaller and lighter (up to 12 lbs.) Allows accessories to be directly mounted to the partition, such as: fire extinguisher, flare kit, first aid kits, acc.

INSTR. NUMBER : 66994	PG: 1	REV: C	ITEM NO.	PART NUMBER	DESCRIPTION	QTY.
PART NUMBER : PARFTL			1	49900	SS ANCHOR ASSM	1
			2	49903-B	CURBSIDE MTG BRKT ASSM	1
PART DESC. : COMP PAR, W/WDO, FTL			3	49904-B	STREETSIDE MTG BRKT ASSM	1
			4	49907-B	CROSS CHANNEL ASSM	1
NOTE: THIS INSTRUCTION WORKS FOR PARFTL2 AND PARFTL-NW. (WINDOW AND NON-WINDOW PARTITIONS)			5	49910-B	ACCESSORY MTG. CHANNEL, PARFT	2
			6	49917	PAR ASSM, W/WDO, FTL	1
			7	50941-B	RAIL AD, PARFTL	1
			8	66195-B	FOOTER,FTL,NO DRILL,COMP	1
			9	49913	UPPER SEAL, PARFTL	1

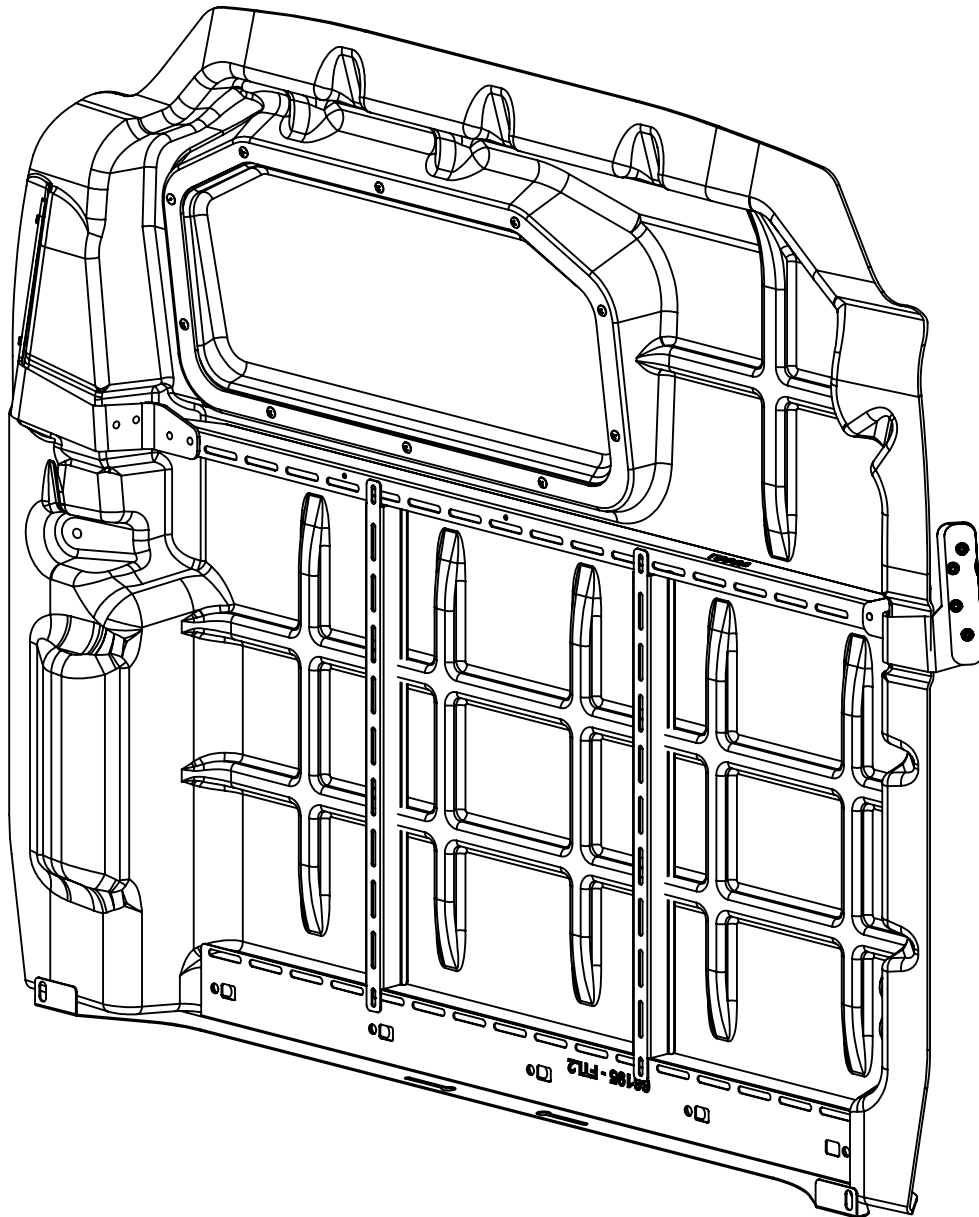

GET TO KNOW THE VEHICLE - AT THE BEGINNING OF ANY INSTALLATION, CHECK THE LOCATION OF THE FUEL TANK, FUEL LINES, BRAKE LINES, HIGH VOLTAGE BATTERIES AND WIRING HARNESSSES TO AVOID INJURY OR PROPERTY DAMAGE FROM TOOL CONTACT.

SEAL ALL EXTERIOR HOLES - ALL INSTALLATION HOLES SHOULD BE SEALED WITH BUTYL TAPE OR SILICON TO PREVENT WATER AND EXHAUST GASES FROM ENTERING THE VEHICLE.

CONTROL DRILL DEPTH - TO AVOID DAMAGE TO THE VEHICLE, USE A DRILL STOP OR CLEARED STEP BIT WHEN DRILLING INSTALLATION HOLES.

ALWAYS ADD PRIMER - WHEN ADDING INSTALLATION HOLES BE SURE TO USE A SELF-ETCHING PRIMER TO PREVENT CORROSION, FASTENER FAILURE AND INJURY.

MOUNTING POINTS MUST HAVE METAL-TO-METAL CONTACT - USE PROVIDED MOUNTING SPACERS TO ACCOMMODATE FOR VEHICLE FEATURES, CARPET OR SUBFLOORS.

PROVIDE CLEARANCE FOR SPACERS - IF THE INSTALLATION VEHICLE CONTAINS A CARPET OR SUBFLOOR, USE A 1-3/16" DIAMETER CARPET CUTTER (P/N: 31183-0) AT ALL MOUNTING LOCATIONS TO OPEN UP ROOM FOR SPACERS.

CHECK SPACER ORIENTATION - BE SURE THAT THE INDENT IN THE SPACER COVERS THE PLUSNUT HEAD; THIS ENSURES THE MOST METAL-TO-METAL CONTACT AND REDUCES VIBRATION.

PLUSNUT INSTALLATION - A PLUSNUT GUN IS RECOMMENDED FOR PLUSNUT INSTALLATION FOR ITS PRODUCTION SPEED. HOWEVER, A PLUSNUT SETTING TOOL CAN ALSO BE USED (P/N: 22200-0).

THRU-BOLT CLEARANCE - WHEN USING A THRU-BOLT AT ANY MOUNTING LOCATION, BE SURE THAT YOUR HOLE HAS 1/16" CLEARANCE.

FASTENERS USED

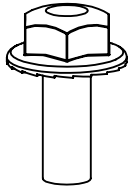

FAS0018
1/4-20X.62 ZP
HFLNG SCREW
QTY: 4



FAS0067
1/4-20 ZP
FLAT WASHER
QTY: 4

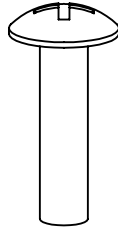

FAS0069
1/4-20X1 ZP
THP SCREW
QTY: 2



FAS0085
5/16 ZP
EXT LCK WASHER
QTY: 18

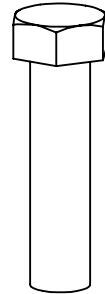

FAS0093
5/16-18X1.25 PF
HH SCEW
QTY: 8



FAS0112
5/16 ZN
FLAT WASHER
QTY: 12



FAS0123
1/4 ZN
EXT LCK WASHER
QTY: 4

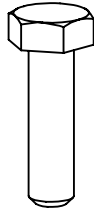

FAS0187
M6-1.0X22 SS
HHH SCREW
QTY: 2



FAS0248
5/16-18 SS
NLK HEX NUT
QTY: 4

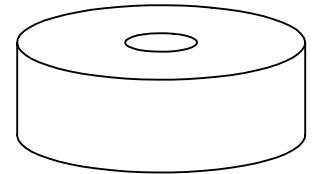

FAS0253
1.50X0.375X.5
IV-2 WASHER
QTY: 5

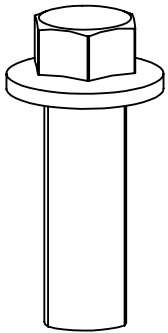

FAS0408
7/16-20X1.63
HH SCREW
QTY: 2



FAS0482
7/16 ZP
FLAT WASHER
QTY: 2

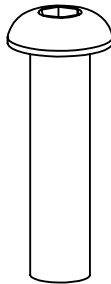

FAS0708
5/16-18X1.25 ZP
BHC SCREW
QTY: 10

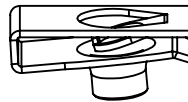

FAS0711
1/4-20 PH
SPRING CLIP
QTY: 4

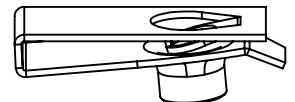

FAS0752
5/16-18 PH
SPRING CLIP
QTY: 5



FAS0833
1.5" FLANGED
CUP WASHER
QTY: 5



03927-1
11/32 ZP
FLR SPACER
QTY: 2



**#2 EXTR RAIL
END CAP
QTY: 2**

VEHICLE PREP
STEP 1 - REMOVE OEM GRAB HANDLE



POP OEM GRAB HANDLE COVERS OFF

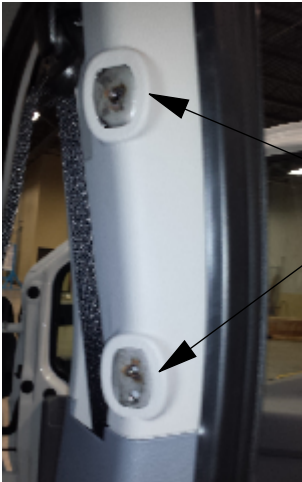

REMOVE OEM FASTENERS (10mm)



COMPONENTS CAN BE SAVED FOR LATER RE-ASSEMBLY

BEGIN INSTALLATION
STEP 2 - INSTALL FOOTER

NOTE: IF A FLOOR PLATE KIT IS INCLUDED IN THIS UPFIT, INSTALL THE FLOOR PLATE BEFORE THIS PARTITION FOOTER

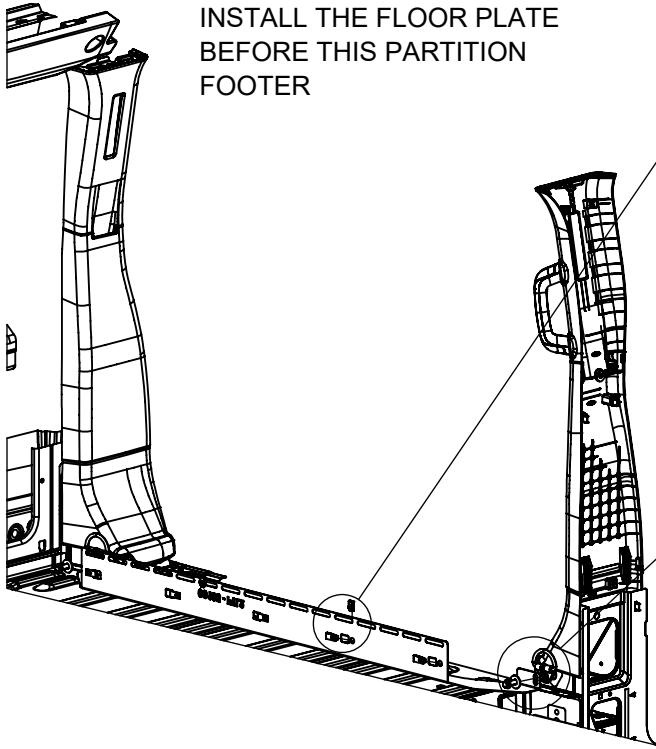

FAS0711 (SMALLER)
(2 PLACES, FACING CABSIDE)
6TH SLOT & 12TH SLOT
FROM DRIVER'S SIDE

FAS0752 (LARGER)
(5 PLACES FACING CARGOSIDE)

REMOVE OEM
D-RING & REPLACE

- OR -

FAS0408, FAS0482
(2 PLACES)
1/2 SCOKET

STEP 3 - INSTALL PASSENGER'S SIDE BRACKET

FAS0187, FAS0060
FAS0067, 03927-1
(2 PLACES)
MOUNT TO OEM HANDLE HOLES
10mm SOCKET

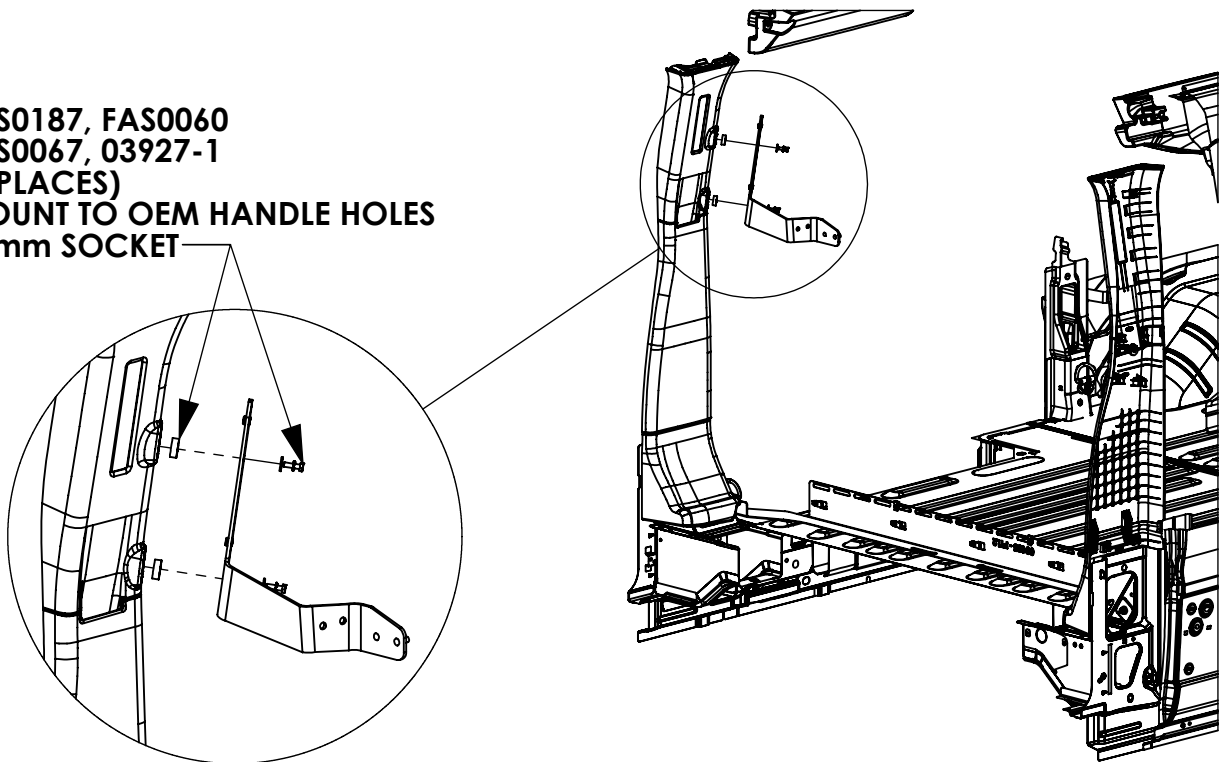

STEP 4 - INSTALL DRIVER'S SIDE BRACKET

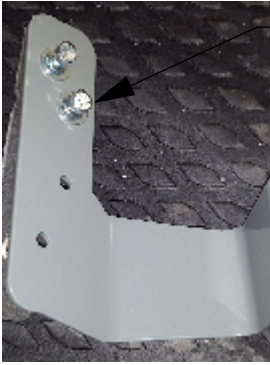

LOOSELY INSTALL TOP
(2) FAS0093, (2) FAS0085
(2) FAS0112



FIT INTO OEM
CUTOUT

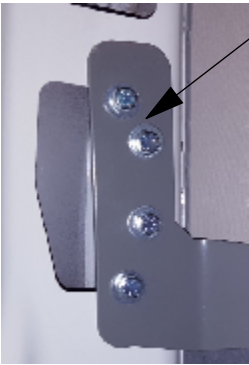

SLIDE TO TOP OF CUTOUT.
INSTALL BOTTOM (2) FAS0093
(2) FAS0085, (2) FAS0112

TIGHTEN ALL FASTENERS IN PLACE

STEP 5 - INSTALL CROSS CHANNEL

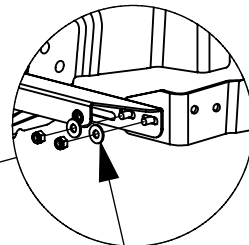
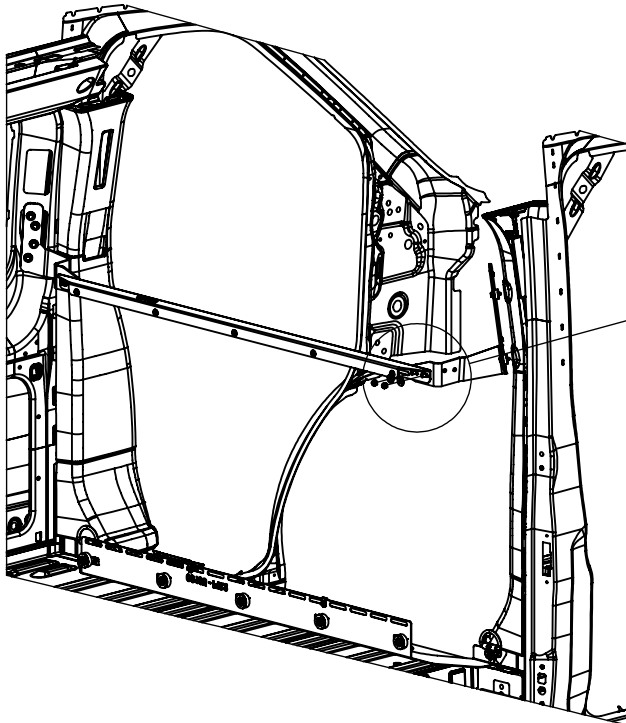

FAS0112, FAS0248
(4 PLACES)
1/2 SOCKET

STEP 6 - INSTALL ACCESSORY MOUNTING CHANNELS

**FAS0018
(2 PER MOUNTING CHANNEL)
7/16 SOCKET**

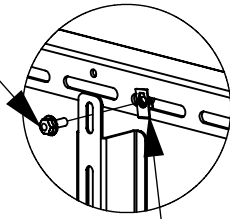

**FAS0711
(2 IN CROSS CHANNEL)
5TH & 11TH CHANNEL
FROM DRIVER'S SIDE**

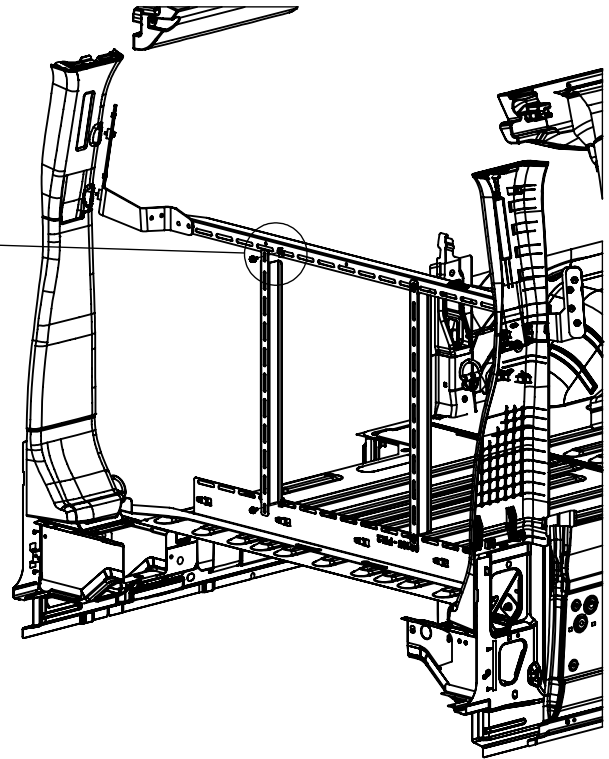

STEP 7 - ASSEMBLE UPPER SEAL

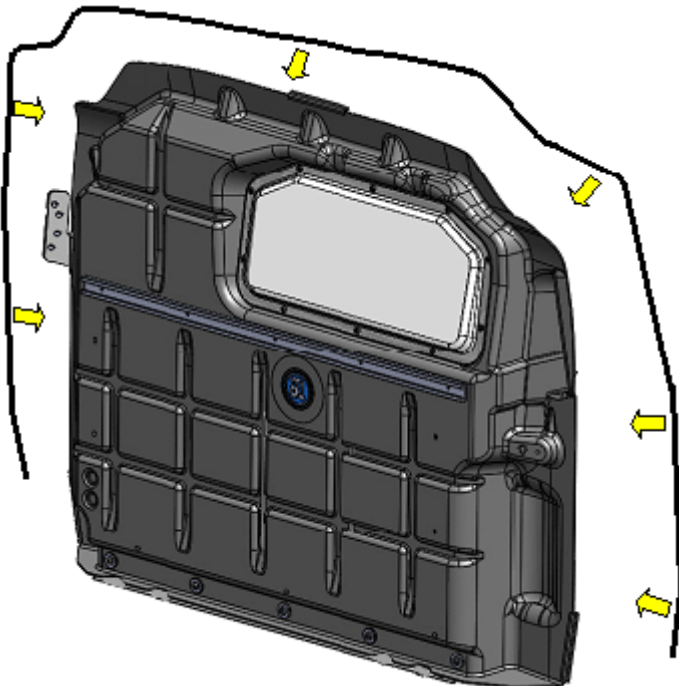

**ATTACH BULB SEAT FACING TOWARD
THE CAB SIDE OF THE PARTITION**

STEP 8 - PLACE PARTITION IN VEHICLE

**PLACE COMPOSITE PANEL
OVER INSTALL FRAME.**

PLACE HEADER PRIOR TO FOOTER.

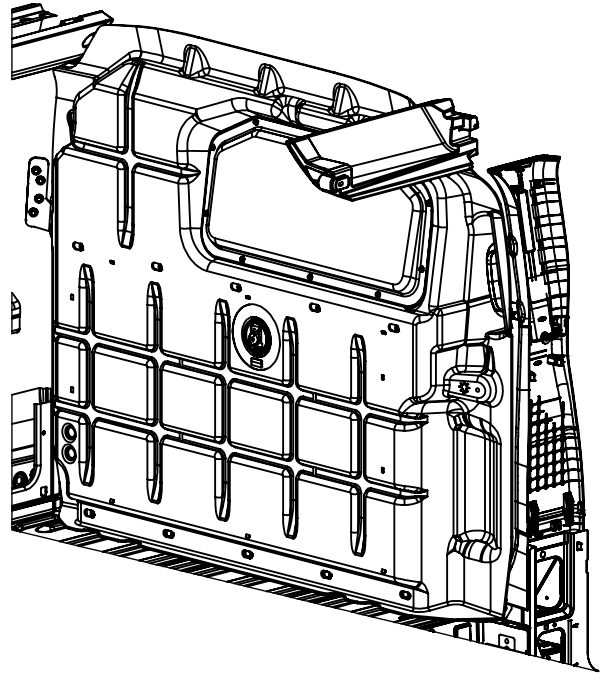

STEP 9 - INSTALL RETAINING RAIL

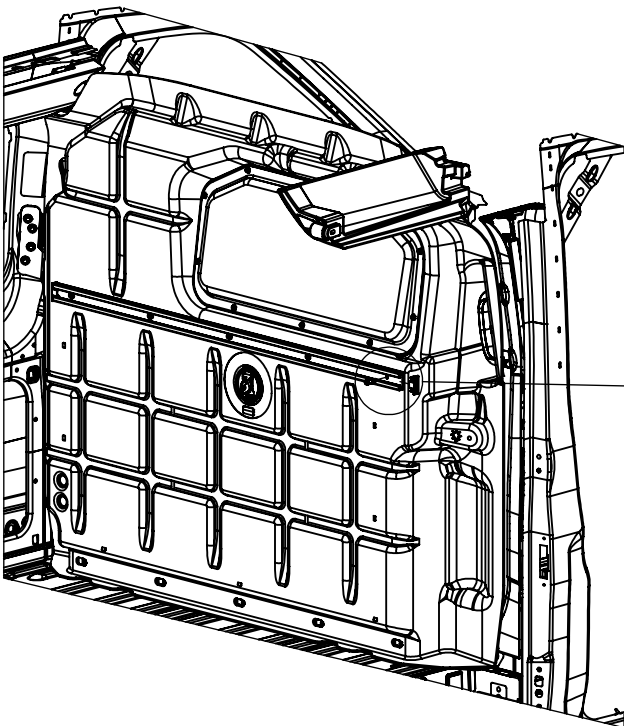

**ADD END CAPS
TO EACH END
OF RAIL**

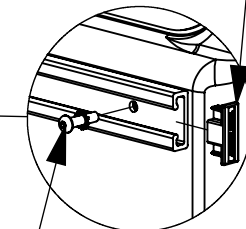

**FAS0708, FAS0085
(5 PLACES)
5/32 ALLEN**

STEP 10 - MOUNT FOOTER FASTENERS

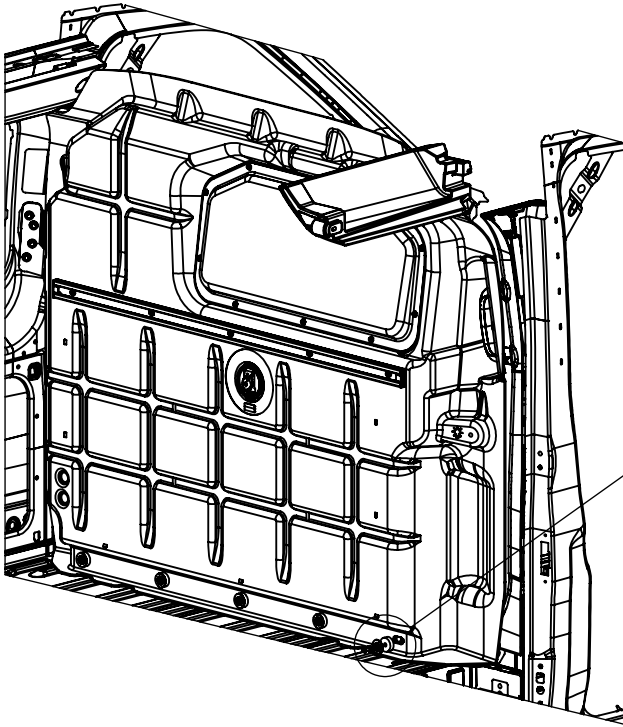

FAS0708, FAS0085,
FAS833, FAS0253
(5 PLACES)
5/32 ALLEN
MOUNT TO FOOTER U-CLIPS

STEP 11 - (OPTIONAL) REPLACE OEM GRAB HANDLE



CUT OFF OEM LOCATOR TABS

ATTACH GRAB HANDLE TO THE
PARTITION USING (2) FAS0069
(2) FAS0123
RE-ATTACH SNAP ON COVERS.

(DO NOT USE POWER TOOLS FOR THIS STEP!)

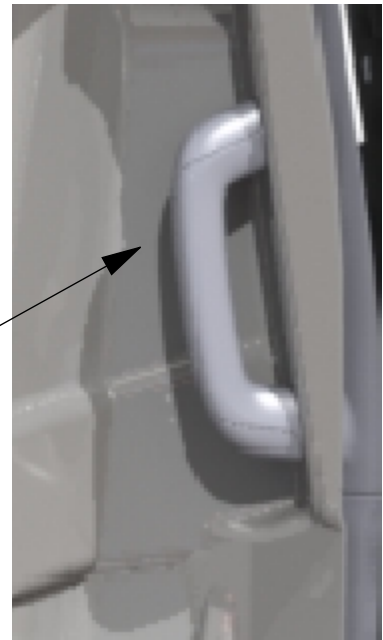

STEP 12 - (OPTIONAL) INSTALL SUPPORT ARM FOR STREETSIDE RAIL KIT

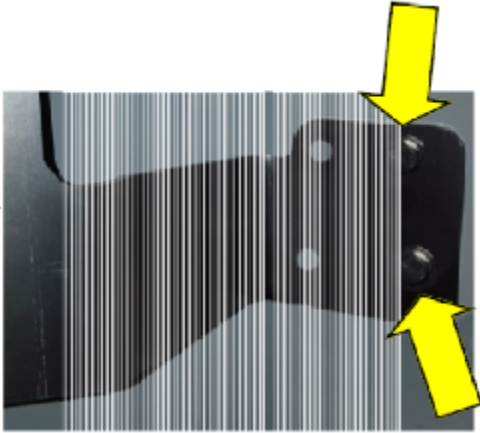

LOOSELY ATTACH DS ANCHOR TO DS MOUNTING BRACKET USING (2) FAS0093 AND (2) FAS0085.



INSERT DS ANCHOR INTO OEM CUTOUT AS SHOWN. RAISE BRACKET INTO CUTOUT AND LOOSELY INSTALL REMAINING (2) FAS0093 AND (2) FAS0085.



PUSH BRACKET ASSEMBLY AGAINST THE TOP OF THE OEM CUTOUT AND FULLY TIGHTEN FASTENERS DOWN.