

1/4-20x1 HH SCREW
 LOCK WASHER
 FLAT WASHER
 PLUSNUT

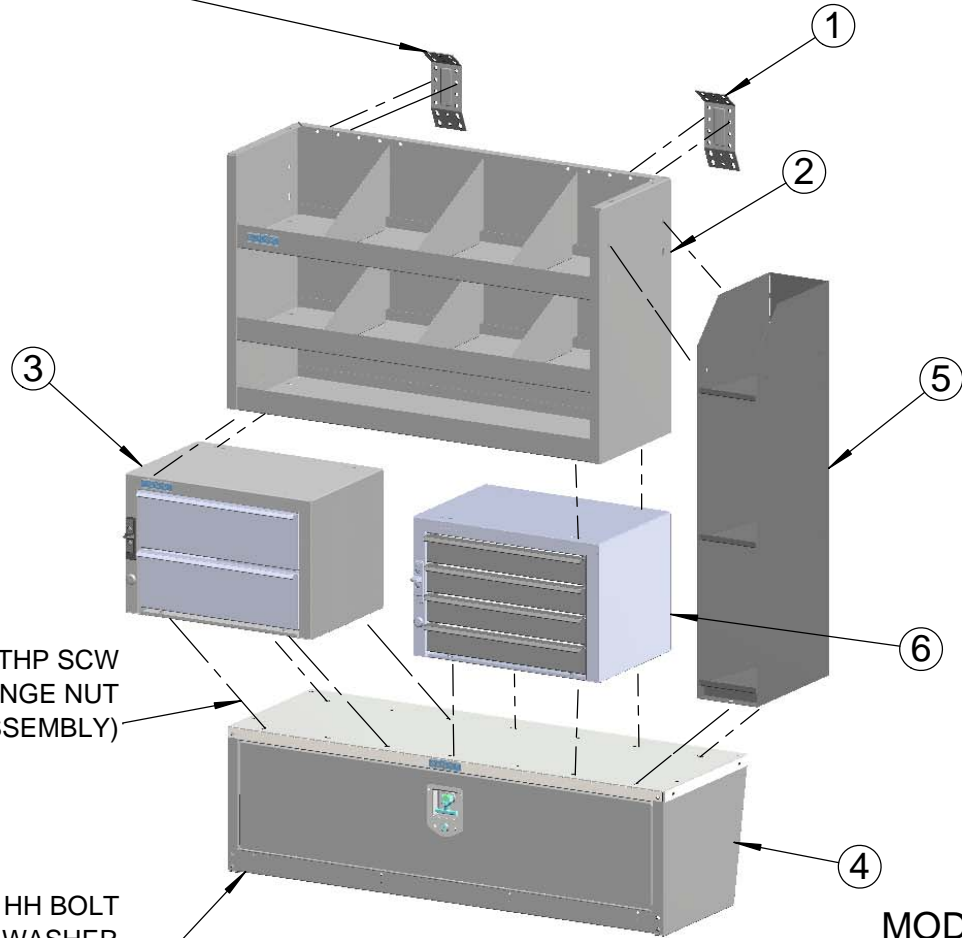

1/4-20x1/2 THP SCW
 FLANGE NUT
 (TYP.ASSEMBLY)

5/16-18x1-1/2 HH BOLT
 LOCK WASHER
 FLAT WASHER
 PLUSNUT

ITEM	PART #	DESCRIPTION	QTY
1	MB111	BRKT, MTG, W/FAS	2
2	18	SHELF RACK / WELDED	1
3	19	2-DRAWER MEDIUM	1
4	40	WHEELHOUSE BIN - KD	1
5	43	CATALOG FILE 34"	1
6	9	4-DRAWER SHALLOW	1

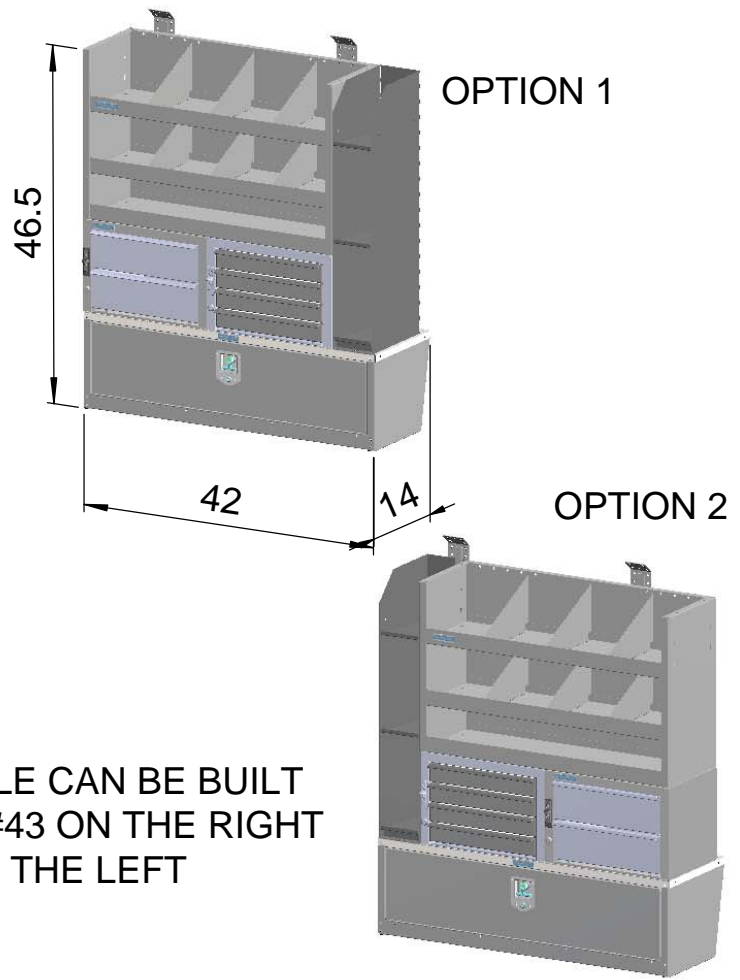

MODULE CAN BE BUILT
 WITH #43 ON THE RIGHT
 OR ON THE LEFT

PRINTED DOCUMENT IS UNCONTROLLED

ADRIAN STEEL
 VAN AND PICKUP EQUIPMENT
 CARGO MANAGEMENT SOLUTIONS FOR COMMERCIAL VEHICLES
 906 James St., Adrian, Michigan 49221
 517.265.6194
 www.adriansteel.com

Customer:
DRAWER/CABINET/RACK
MODULE
14 X 46.5 X 42

Drawn By:
BDS
 Date:
03/09/2015
 ECN No:
6071
 PART No:
MD507

CAUTION:
 DRILL THRU FLOOR WITH CARE!
 WATCH FOR GAS TANK, CONTROL
 LINES, & ELECTRICAL WIRING.

Part Weight:
137.91

CG Horizontal & Vertical:
 HCG=**21.00** VCG=**23.00**

Sheet:
1 of 1

Rev.: **A**

APPLICATION OF UNIVERSAL MOUNTING BRACKET #8308-0

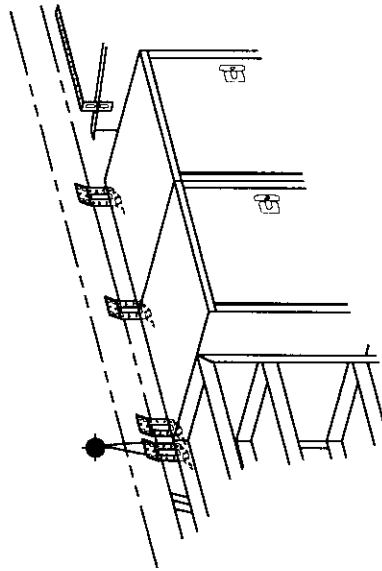

FIG. 1

CABINETS BELOW THE HEADER RAIL WILL NEED THE UNIVERSAL MOUNTING BRACKET AT EACH END OF ADJOINING CABINETS, AS SHOWN IN FIG'S 1,2, & 3.

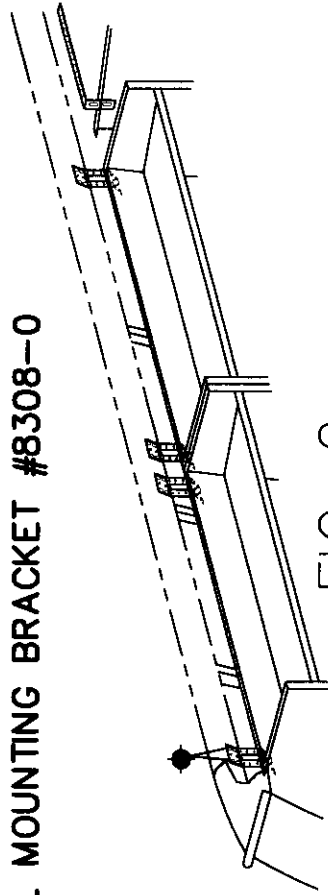

FIG. 2

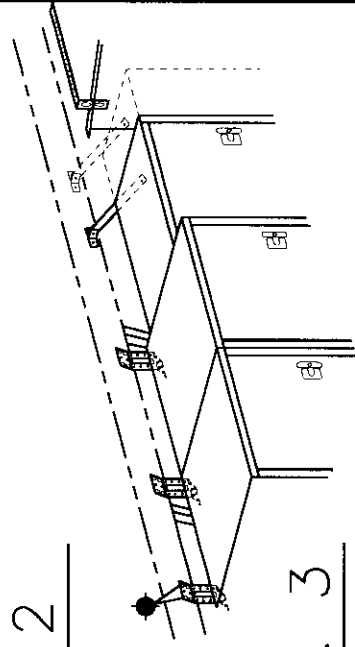

FIG. 3

OBSTRUCTIONS ON THE HEADER RAIL SUCH AS THE SHOULDER BELT ANCHOR, MAY REQUIRE A DIFFERENT TYPE OF MOUNTING BRACKET TO POSITION THE CABINETS OUT & AWAY FROM THE HEADER RAIL AS SHOWN IN FIG. 3.

FIG. 4

TYPICAL POSITIONING OF MOUNTING BRACKET FOR EACH STYLE HEADER RAIL.

1996 & OLDER
CHV/GMC

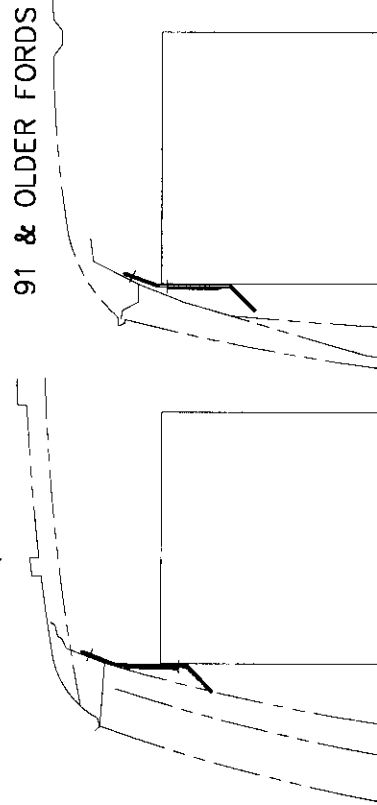

DODGE
91 & OLDER FORDS

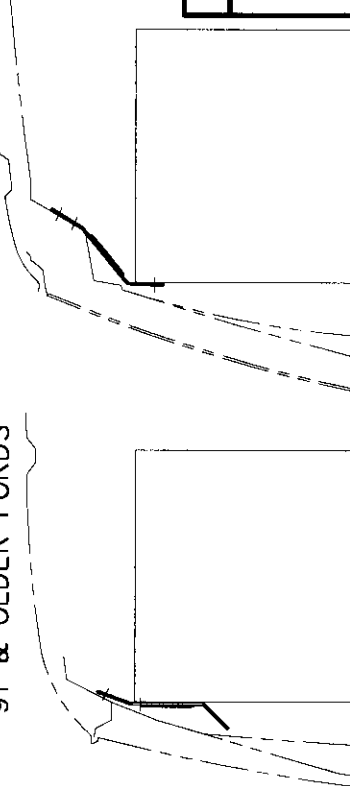

1997 CHV/GMC
1992 & NEWER FORD

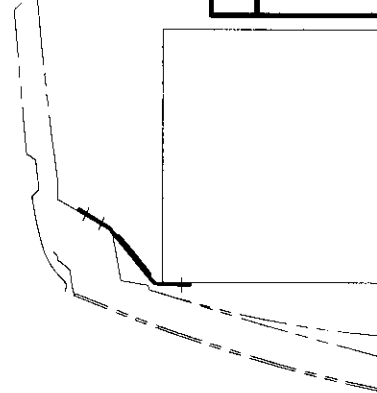

NEW STYLE 1995

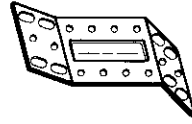

#8308-0 UNIVERSAL MOUNTING BRACKET
(REVISED MAY OF 1995)

EN- 4758

DATE: MAY/3/99



ADRIAN STEEL COMPANY

906 JAMES STREET ADRIAN, MI 49221
cabinets designed to serve

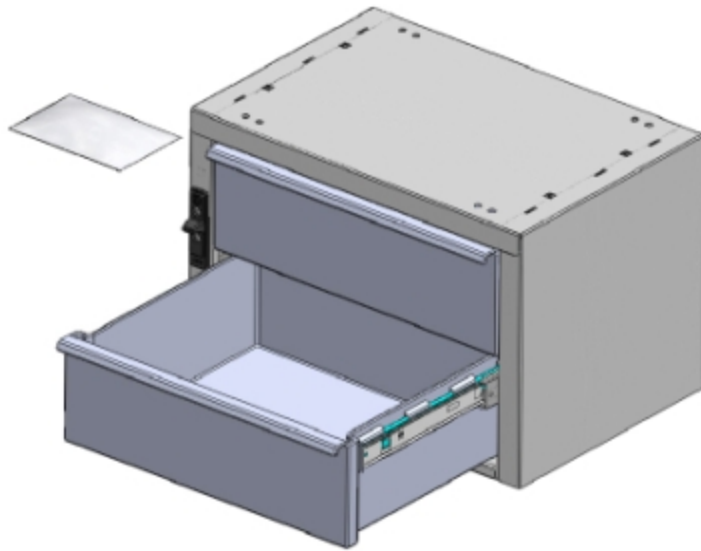
**19, 2-DRAWER MEDIUM***PRODUCT WEIGHT***27.4 lbs.***WIDTH x DEPTH x HEIGHT***18 x 12 x 12***CAPACITY***25 LBS. PER DRAWER***COLOR***GRAY***CATALOG NUMBER***19***PRODUCT FEATURES*

The drawer unit body is a sturdy welded and painted steel housing. The housing has ¼-20 riv-nuts installed into the base of the unit for easy installation. Also included are pre-drilled mounting holes in the top of the cabinet to allow for quick and easy stacking of the units. The number 19 drawer unit includes two (2) polymer drawers that ride on full extension ball bearing glides. The drawers have an inside dimension of 13.50" wide X 4.5" deep X 11.50" length. Each cabinet includes a sliding latch/lock system designed to secure the drawers during vehicle movement. A cam lock allows for securing your inventory for more security.

PRODUCT APPLICATION

This product is designed to be used in and/or on ADRIAN STEEL shelving units and can also be used as a standalone product. The product is great for small parts and supplies storage.

Introduction / Comments:

The drawer unit body is a sturdy welded and painted steel housing. The housing has 1/4-20 riv-nuts installed into the base of the unit for easy installation. Also pre drilled mounting holes in the top of the cabinet to allow for quick and easy stacking of units. 2 polymer drawers ride on ball bearing glides. Each cabinet includes a sliding latch/lock system designed to secure the drawers during vehicle movement. A cam lock allows for securing your inventory for more security

Note:

It is advised that all fasteners used in this assembly and installation should be checked for tightness at the following intervals: @ 2-weeks and again @ 6-weeks of operation. This preventive maintenance step must be completed to ensure your Product gives you long service life.

ITEM NO.	PART NUMBER	DESCRIPTION	19S/QTY.
1	39197-G	WRAPPER BODY ASSM	1
2	40016	DRAWER SUB ASSY. 19/919	2
3	40827-LH	250MM SLIDE, CABINET HALF, LH	2
4	40287-RH	250MM SLIDE, CABINET HALF, RH	2
5	BAG00001-0	FASTENER BAG 9,19,919	1

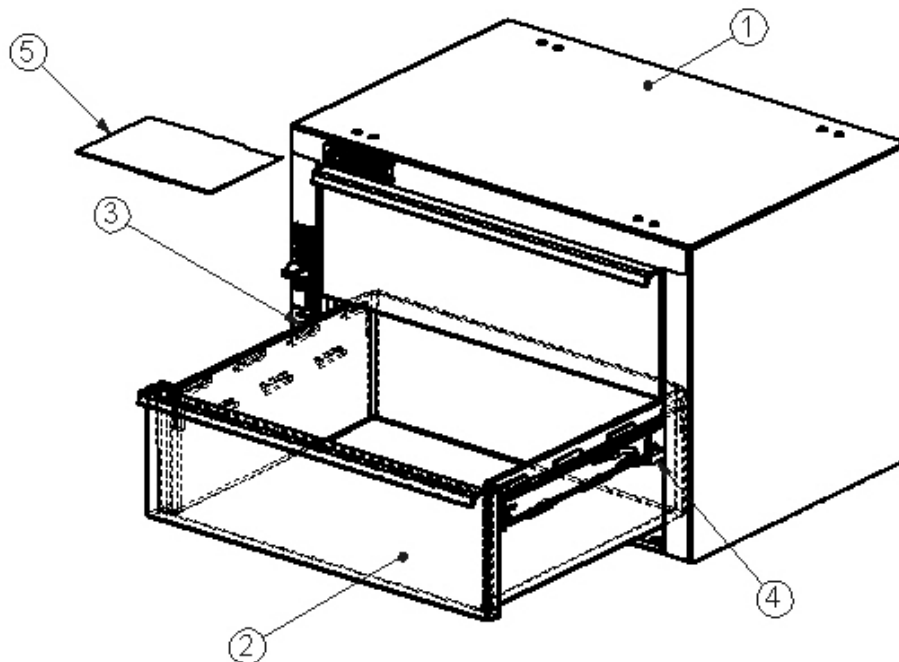

19
2 DRAWER MEDIUM

- PRECAUTIONS -



CAUTION
THE USE OF AIR IMPACT TOOLS CAN
OVER-TORQUE FASTENERS AND
CAUSE FASTENER FAILURE!



CAUTION
ALL INSTALLATION HOLES SHOULD BE SEALED
WITH SILICON OR BUTYL SEALANT TO PREVENT
EXHAUST FUMES FROM ENTERING THE VEHICLE!



DANGER
INSPECT FOR FUEL TANK, FUEL LINES, BRAKE LINES, HIGH
VOLTAGE BATTERIES AND ELECTRICAL LINES PRIOR TO
DRILLING TO AVOID DAMAGING CRITICAL VEHICLE SYSTEMS
OR INJURY TO INSTALLER DURING INSTALLATION PROCESS!



CAUTION
TO AVOID DAMAGING THE VEHICLE ALWAYS USE DRILL
STOPS WHEN DRILLING ANY INSTALLATION HOLES!
ADRIAN AVAILABLE PART #'S 31119-0 (3/8" X 1/2"
DEEP), 31121-0 (1/2" X 1/2" DEEP)



- IMPORTANT WARRANTY REQUIREMENTS -

1. SUBSTITUTING ADRIAN STEEL SPECIFIED FASTENERS FOR ASSEMBLY AND/OR INSTALLATION WILL VOID YOUR PRODUCT WARRANTY.
2. ALL HOLES DRILLED INTO VEHICLE SHOULD HAVE THE RAW METAL EDGES SEALED WITH A SELF-ETCHING PRIMER TO RESIST CORROSION AND POTENTIAL FASTENER POINT FAILURE.
3. ALL FASTENERS USED IN THE INSTALLATION OF THIS PRODUCT SHOULD BE TIGHTENED TO THE TORQUE(S) SPECIFIED IN THESE INSTRUCTIONS.
4. THESE INSTRUCTIONS SHOULD BE KEPT WITH THE VEHICLE.

THE BASIC TOOLS NEEDED FOR MOST INSTALLATIONS



DRILL



DRILL BIT WITH
STOP



RATCHET, SOCKETS
AND/OR WRENCHES



SCREWDRIVERS



MEASURING TAPE

ADDITIONAL TOOLS MAY BE NEEDED FOR THIS INSTALLATION AND THEY WILL BE IDENTIFIED IN THE STEPS THAT FOLLOW.

If your vehicle contains carpet or a rubber floor mat you will need to prepare the mounting location. Position the product to be installed into the vehicle and once you are satisfied with the mounting locations, mark the mounting locations. Using a 1-3/16" diameter carpet cutter (P/N: 31183-0). Select the appropriate floor spacers as shown in the illustration. Set those aside for use later into the installation process. Using the correct drill bit size for the selected plusnut, drill the mounting holes in the vehicle sheet metal to prepare for installing the plusnuts. If you are thru-bolting at any of the locations simply drill a hole that is 1/16" larger than the bolt size(s) for those locations. Once you have drilled the holes into the vehicle, the raw metal edges should be sealed using a self-etching primer to resist corrosion and potential fastener point failure.

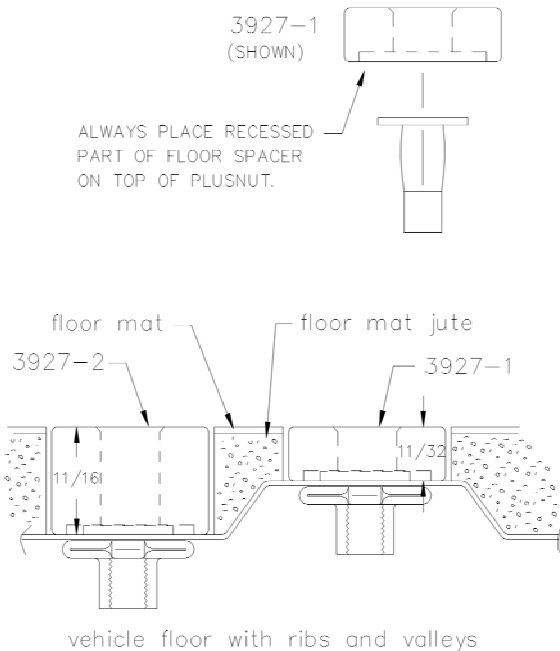

A PLUSNUT (RIVNUT) SETTING TOOL IS REQUIRED FOR PLUSNUT (RIVNUT) INSTALLATION . PLUS NUT SETTING TOOL CAN BE ORDERED THROUGH ADRIAN STEEL, OR USE AN AIR POWERED PLUSNUT SETTING GUN.

1/4-20UNC Plusnut (FAS0052) Use 3/8" dia. drill w/stop
 FAS0080 SCREW, HXHD, 1/4-20UNCx2.00", G8
 FAS0067 WASHER, FLAT, 1/4"ID
 22200-0 PLUSNUT TOOL

5/16-18UNC Plusnut (FAS0091) Use 1/2" dia. drill w/stop
 FAS0095 SCREW, HXHD, 5/16-18UNCx2.00", G8
 FAS0086 WASHER, FLAT, 5/16"ID
 22200-0 PLUSNUT TOOL

Place barrel of the plusnut body in sheet metal thru hole until flange is flush with sheet metal.
 Using a 9/16" combination wrench of plusnut tool body and a second hand wrench, ratchet, or air tool, rotate the hex bolt head CW to draw plus nut flanges up (set the plusnut).

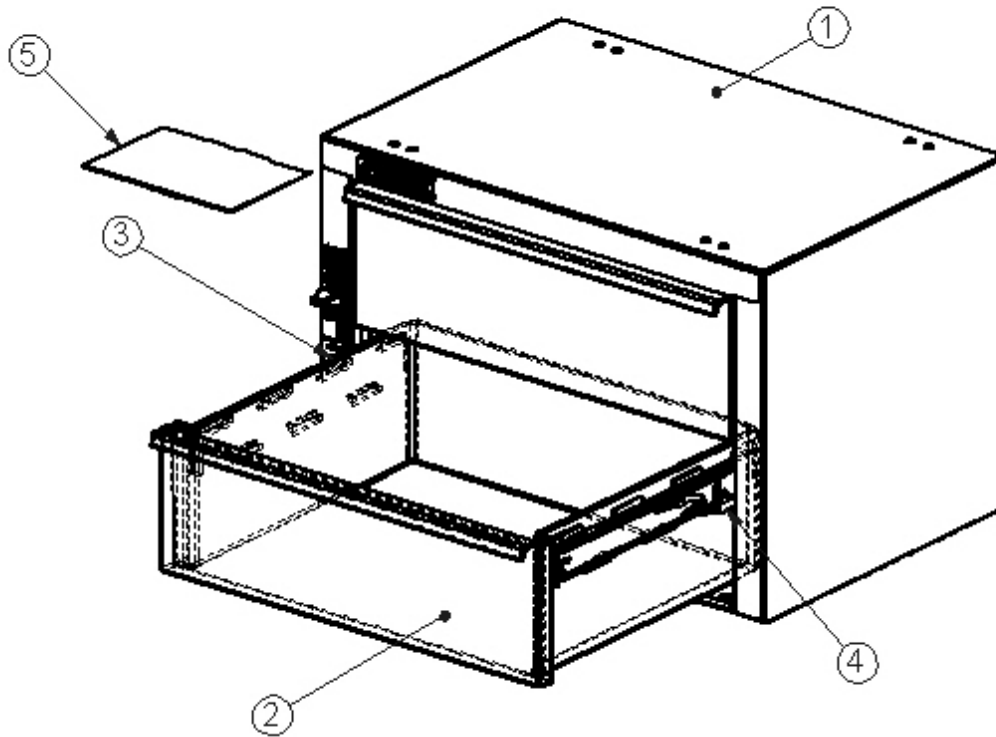

INSERT TWO (2) 40287-LH AND TWO (2) 40287-RH SLIDES INTO CABINET BODY.
INSERT TWO (2) 40016 DRAWERS INTO CABINET BODY.
PLACE BAG00001-0 INTO THE SECOND DRAWER. TAPE
THE LOCK KEYS INTO THE FRONT RIGHT BOTTOM OF THE SECOND
DRAWER AND CLOSE THE DRAWERS.

ITEM NO.	PART NUMBER	DESCRIPTION	BAG00001-0./QTY.
1	BAG0505-A	5" x 5" 3MIL AUTOBAG	1
2	FAS 0066	Washer, Lock, Ext. Tooth, 1/4	4
3	FAS0520	Screw, Truss Hd. Ph, 1/4-20x .375" lg	4

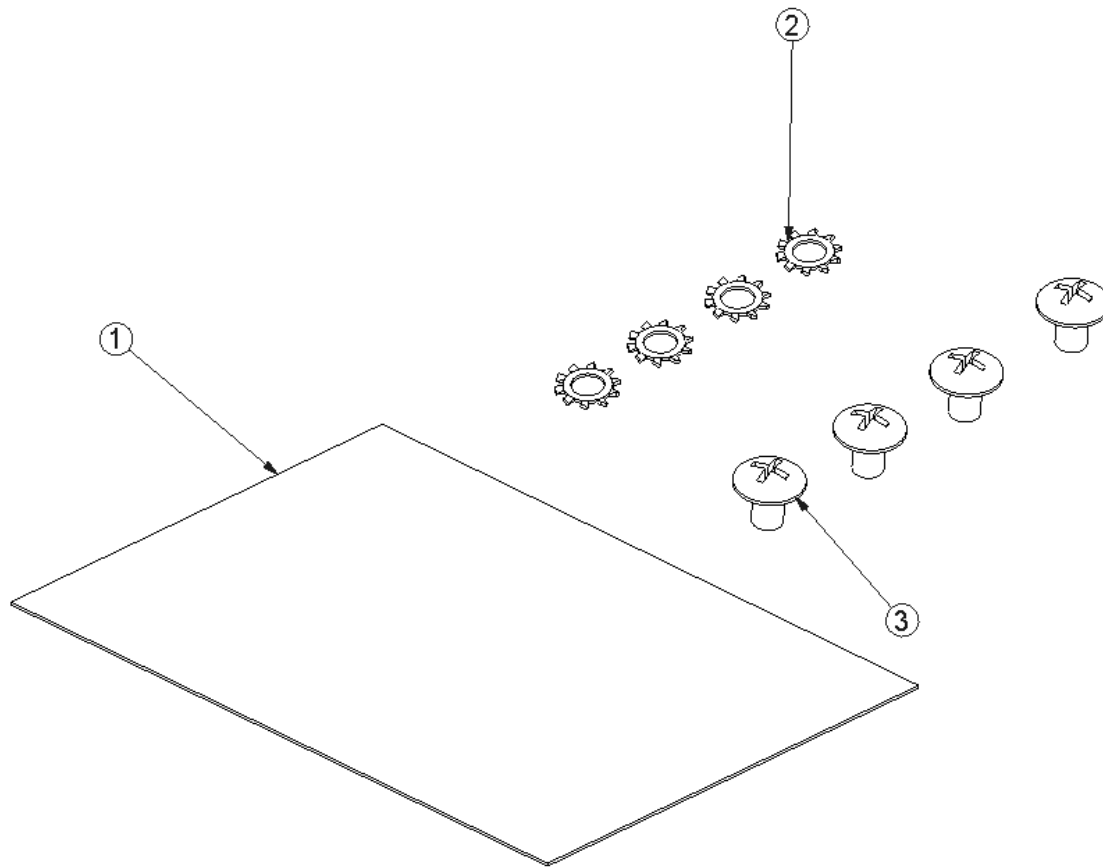

Individual Fastener Images & Descriptions

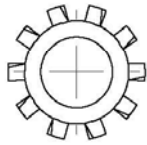

FAS0066
WASHER,LCK EXT 1/4 ZP

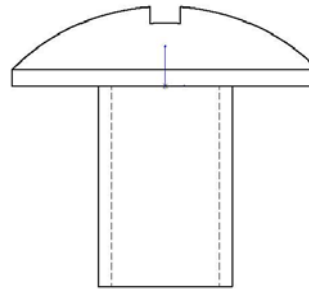
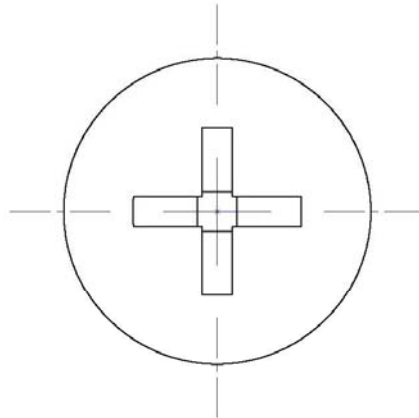

FAS0520
SCREW,THP 1/4-20 X .38
ZP

Step 01 Methods of Attachment

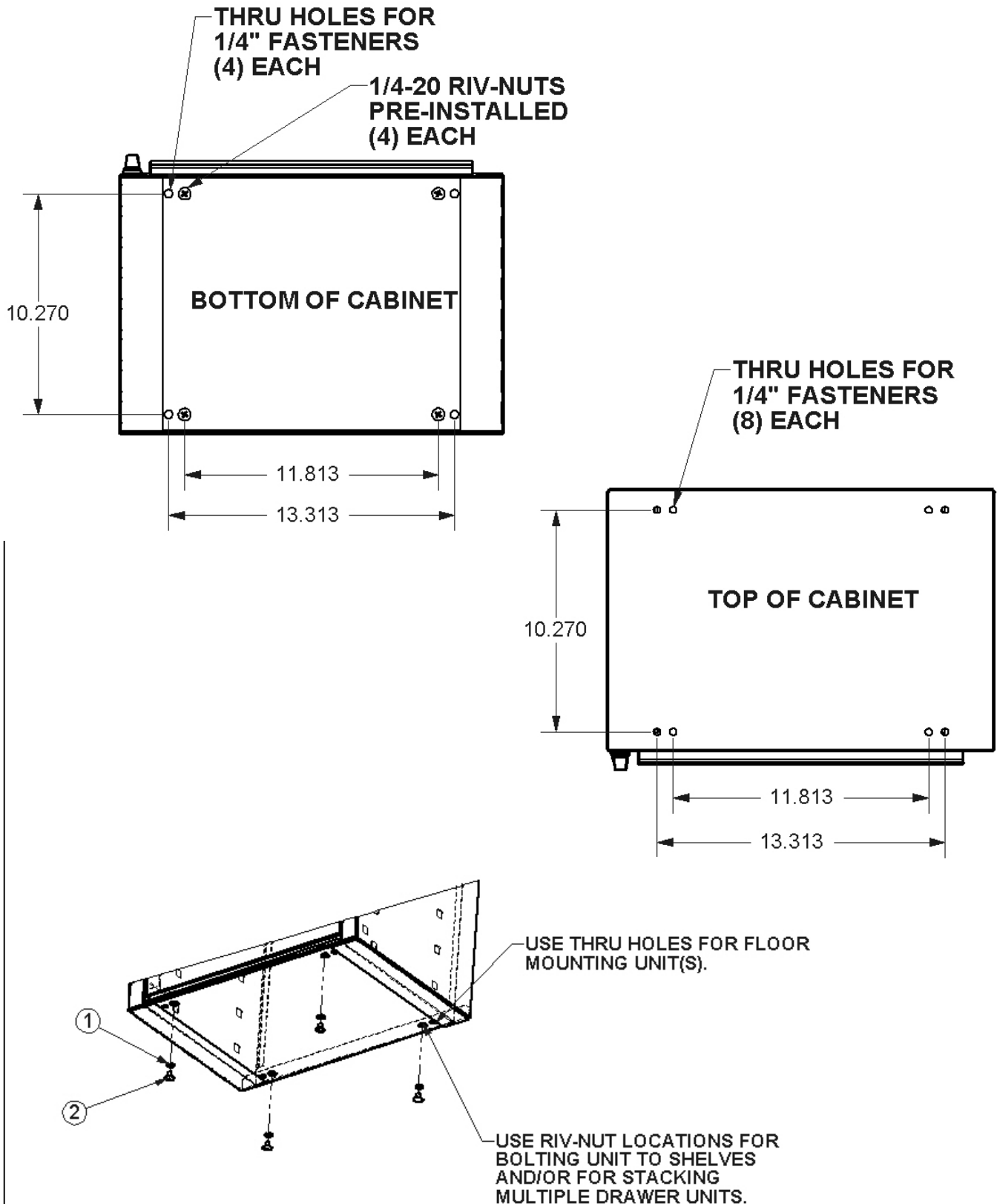

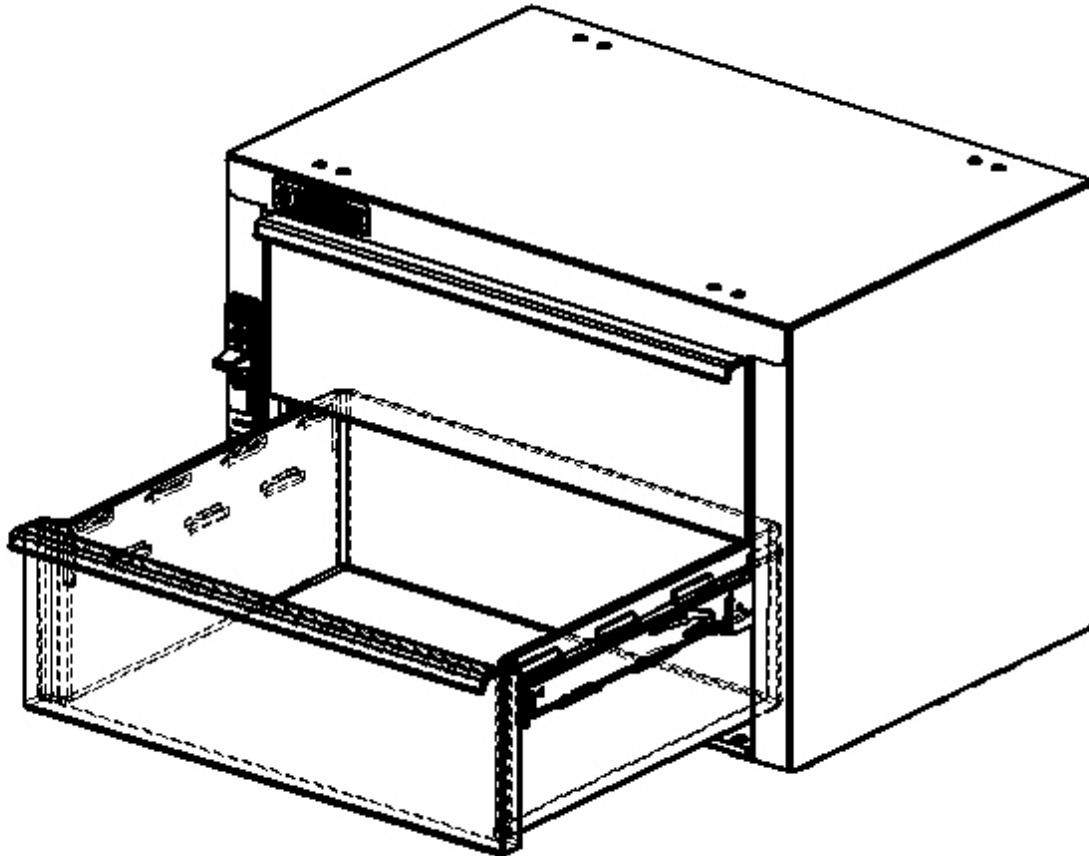

**DOUBLE CHECK ALL FASTENERS LOCATIONS TO BE SURE THAT ALL
FASTENERS ARE TIGHTENED TO SPECIFICATIONS.
YOUR INSTALLATION IS NOW COMPLETE!
STOW THIS COPY IN THE VEHICLE FOR FUTURE REFERENCES!**

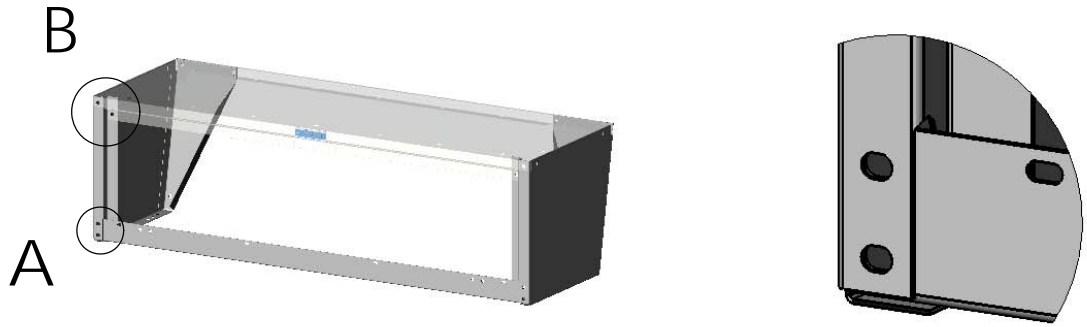

THE TOP PANEL COVERS ALL VERTICAL PIECES, & LEG BRACES. LEG BRACES ARE ASSEMBLED INSIDE THE END PANELS.

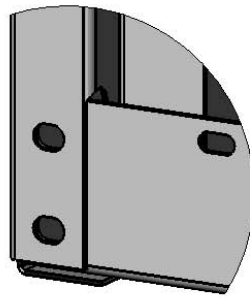

DETAIL A
SCALE 1 : 2

ITEM	PART #	DESCRIPTION	QTY
1	BAG00004-0	#4 BAG FOR #40 BIN/KD	1
2	CRT11946-A	CARTON, PAD FOR 11946	1
3	CRT11946-0	CARTON FOR #11946-0	1
4	FR42	FLOOR RAIL, 42"	1
5	LOGO-SM	0.875X3.00 ADRIAN LOGO	1
6	09311-0	DOOR ASM. 42" (39-5/8)	1
7	11947-0	END PANEL 14" LEFT	1
8	11948-0	END PANEL 14" RIGHT	1
9	11949-0	TOP PANEL 14X42	1
10	12072-0	LEG BRACE/,LEFT	1
11	12073-0	LEG BRACE/,RIGHT	1
12	21000-0	LOCKING T HNDL W/KEY ASCO	1

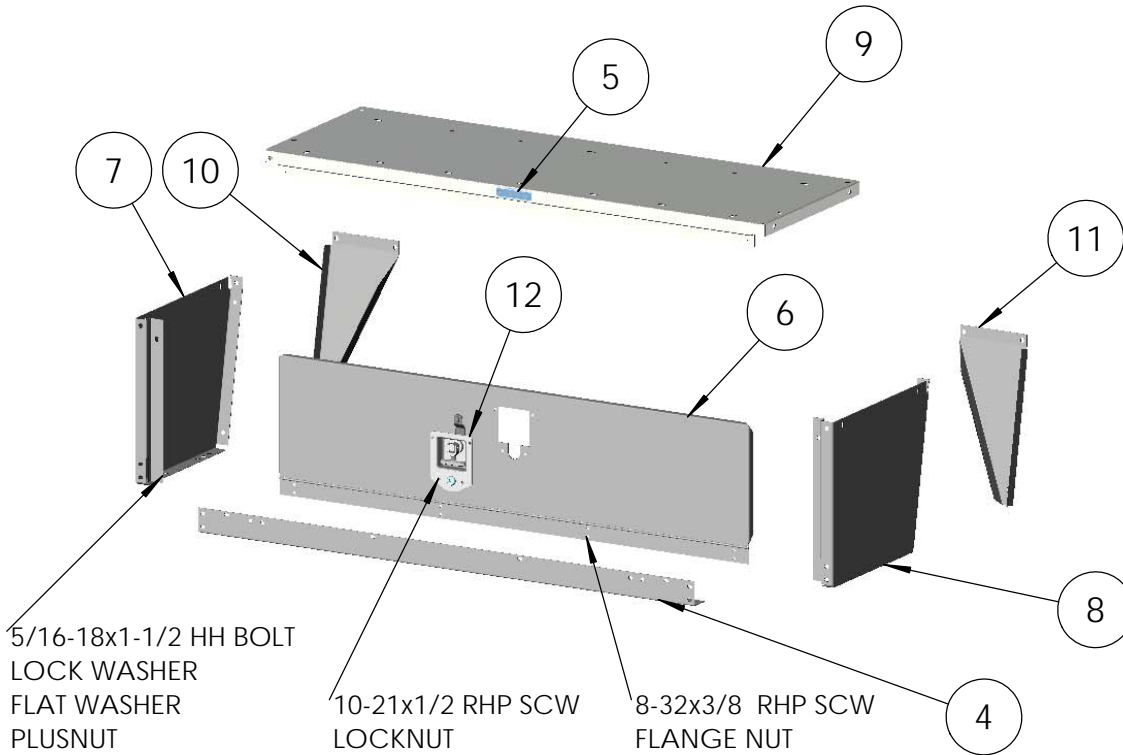

5/16-18x1-1/2 HH BOLT
LOCK WASHER
FLAT WASHER
PLUSNUT

10-21x1/2 RHP SCW
LOCKNUT

8-32x3/8 RHP SCW
FLANGE NUT

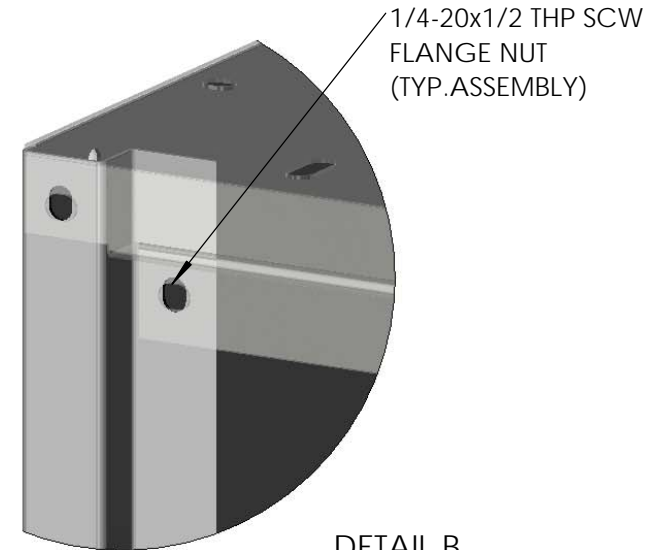

1/4-20x1/2 THP SCW
FLANGE NUT
(TYP.ASEMBLY)

DETAIL B
SCALE 1 : 2

CAUTION: DRILL THRU FLOOR WITH CARE! WATCH FOR GAS TANK, CONTROL LINES, & ELECTRICAL WIRING.

ADRIAN STEEL
Cargo Management Solutions for Commercial Facilities

906 James Street
Adrian, Michigan 49221
517.265.6194
WWW.ADRIANSTEEL.COM

ALL DESIGNS AND DESIGN CONCEPTS ARE THE INTELLECTUAL PROPERTY OF ADRIAN STEEL COMPANY AND ARE NOT TO BE COPIED, DISTRIBUTED OR COMMUNICATED TO OUTSIDE PARTIES WITHOUT THE WRITTEN PERMISSION OF ADRIAN STEEL COMPANY.
THE MATERIAL/CONCEPTS/DESIGNS CONTAINED WITHIN THIS DOCUMENT ARE FOR THE PURPOSE OF SUPPLYING PRODUCT TO POTENTIAL ADRIAN STEEL COMPANY CUSTOMERS.

Drawn By:	BDS	DESCRIPTION			
Date:	03/09/2015	WHEELHOUSE BIN - KD			
ECN No:	12861	14 X 12.5 X 42			
PART No:	40	Part Weight:	CG Horizontal & Vertical:	Sheet:	Rev.:
		27.58	HCG= 21.00 VCG= 6.25	1 of 1	E

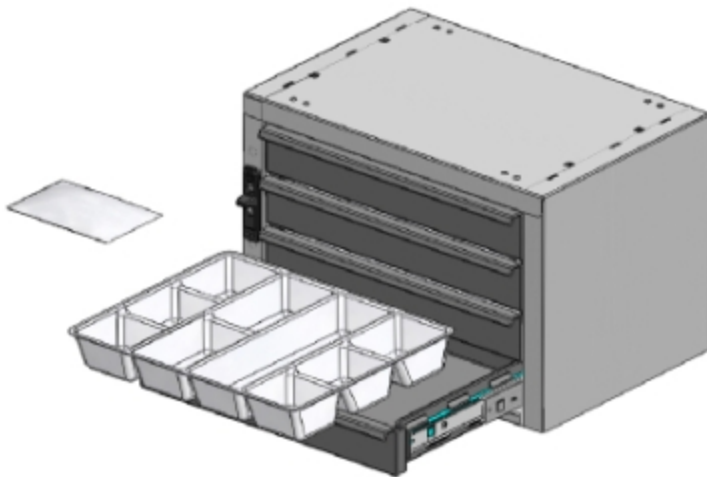
**9, 4-DRAWER SHALLOW***PRODUCT WEIGHT***27.7 lbs.***WIDTH x DEPTH x HEIGHT***18 x 12 x 12***CAPACITY***15 LBS. PER DRAWER***COLOR***GRAY***CATALOG NUMBER***9***PRODUCT FEATURES*

The drawer unit body is a sturdy welded and painted steel housing. The housing has ¼-20 riv-nuts installed into the base of the unit for easy installation. Also included are pre-drilled mounting holes in the top of the cabinet to allow for quick and easy stacking of the units. The number 9 drawer unit includes four (4) polymer drawers that ride on full extension ball bearing glides. The drawers have an inside dimension of 13.50" wide X 2.0" tall X 11.50" deep. The drawers include a removable divider tray for storing smaller parts. Each cabinet includes a sliding latch/lock system designed to secure the drawers during vehicle movement. A cam lock allows for securing your inventory for more security.

PRODUCT APPLICATION

This product is designed to be used in and/or on ADRIAN STEEL shelving units and can also be used as a standalone product. The product is great for small parts and supplies storage.

Introduction / Comments:

The drawer unit body is a sturdy welded and painted steel housing. 4 polymer drawers ride on ball bearing glides. The drawer include a removable divider tray for storing small items. Each cabinet includes a sliding latch/lock system designed to secure the drawers during vehicle movement.

Note:

It is advised that all fasteners used in this assembly and installation should be checked for tightness at the following intervals: @ 2-weeks and again @ 6-weeks of operation. This preventive maintenance step must be completed to ensure your Product gives you long service life.

ITEM NO.	PART NUMBER	DESCRIPTION	QTY.
1	39197-G	WRAPPER BODY ASSM	1
2	40015	DRAWER SUB ASSY. #9/919	4
3	28105-0	Divider Tray 9/919	4
4	40827-LH	250MM SLIDE, CABINET HALF, LH	4
5	40287-RH	250MM SLIDE, CABINET HALF, RH	4
6	BAG00001-0	FASTENER BAG 9,19,919	1

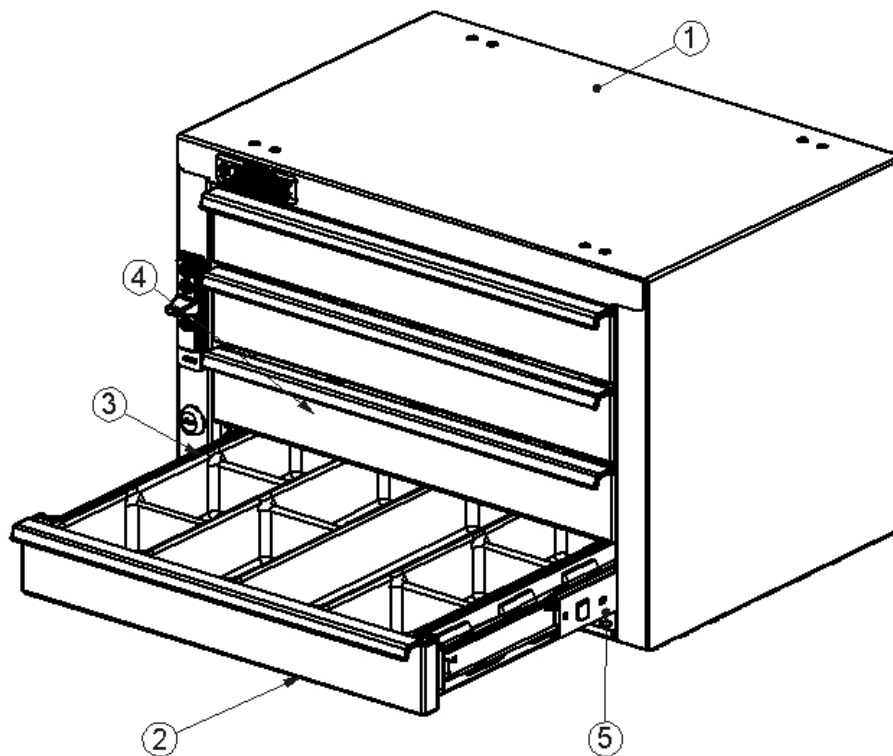

9
4 DRAWER UNIT

- PRECAUTIONS -



CAUTION
THE USE OF AIR IMPACT TOOLS CAN
OVER-TORQUE FASTENERS AND
CAUSE FASTENER FAILURE!



CAUTION
ALL INSTALLATION HOLES SHOULD BE SEALED
WITH SILICON OR BUTYL SEALANT TO PREVENT
EXHAUST FUMES FROM ENTERING THE VEHICLE!



DANGER
INSPECT FOR FUEL TANK, FUEL LINES, BRAKE LINES, HIGH
VOLTAGE BATTERIES AND ELECTRICAL LINES PRIOR TO
DRILLING TO AVOID DAMAGING CRITICAL VEHICLE SYSTEMS
OR INJURY TO INSTALLER DURING INSTALLATION PROCESS!



CAUTION
TO AVOID DAMAGING THE VEHICLE ALWAYS USE DRILL
STOPS WHEN DRILLING ANY INSTALLATION HOLES!
ADRIAN AVAILABLE PART #'S 31119-0 (3/8" X 1/2"
DEEP), 31121-0 (1/2" x 1/2" DEEP)



- IMPORTANT WARRANTY REQUIREMENTS -

1. SUBSTITUTING ADRIAN STEEL SPECIFIED FASTENERS FOR ASSEMBLY AND/OR INSTALLATION WILL VOID YOUR PRODUCT WARRANTY.
2. ALL HOLES DRILLED INTO VEHICLE SHOULD HAVE THE RAW METAL EDGES SEALED WITH A SELF-ETCHING PRIMER TO RESIST CORROSION AND POTENTIAL FASTENER POINT FAILURE.
3. ALL FASTENERS USED IN THE INSTALLATION OF THIS PRODUCT SHOULD BE TIGHTENED TO THE TORQUE(S) SPECIFIED IN THESE INSTRUCTIONS.
4. THESE INSTRUCTIONS SHOULD BE KEPT WITH THE VEHICLE.

THE BASIC TOOLS NEEDED FOR MOST INSTALLATIONS



DRILL



DRILL BIT WITH
STOP



RATCHET, SOCKETS
AND/OR WRENCHES



SCREWDRIVERS



MEASURING TAPE

ADDITIONAL TOOLS MAY BE NEEDED FOR THIS INSTALLATION AND THEY WILL BE IDENTIFIED IN THE STEPS THAT FOLLOW.

If your vehicle contains carpet or a rubber floor mat you will need to prepare the mounting location. Position the product to be installed into the vehicle and once you are satisfied with the mounting locations, mark the mounting locations. Using a 1-3/16" diameter carpet cutter (P/N: 31183-0). Select the appropriate floor spacers as shown in the illustration. Set those aside for use later into the installation process.

Using the correct drill bit size for the selected plusnut, drill the mounting holes in the vehicle sheet metal to prepare for installing the plusnuts.

If you are thru-bolting at any of the locations simply drill a hole that is 1/16" larger than the bolt size(s) for those locations.

Once you have drilled the holes into the vehicle, the raw metal edges should be sealed using a self-etching primer to resist corrosion and potential fastener point failure.

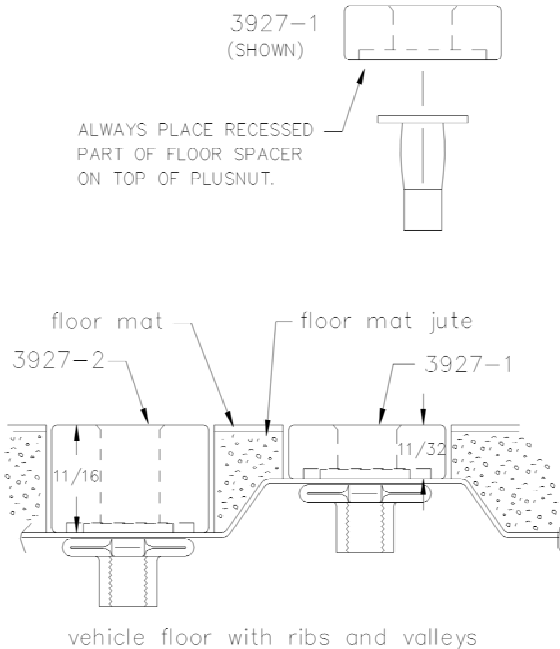

A PLUSNUT (RIVNUT) SETTING TOOL IS REQUIRED FOR PLUSNUT (RIVNUT) INSTALLATION . PLUS NUT SETTING TOOL CAN BE ORDERED THROUGH ADRIAN STEEL, OR USE AN AIR POWERED PLUSNUT SETTING GUN.

1/4-20UNC Plusnut (FAS0052) Use 3/8" dia. drill w/stop
 FAS0080 SCREW, HXHD, 1/4-20UNCx2.00", G8
 FAS0067 WASHER, FLAT, 1/4"ID
 22200-0 PLUSNUT TOOL

5/16-18UNC Plusnut (FAS0091) Use 1/2" dia. drill w/stop
 FAS0095 SCREW, HXHD, 5/16-18UNCx2.00", G8
 FAS0086 WASHER, FLAT, 5/16"ID
 22200-0 PLUSNUT TOOL

Place barrel of the plusnut body in sheet metal thru hole until flange is flush with sheet metal.
 Using a 9/16" combination wrench of plusnut tool body and a second hand wrench, ratchet, or air tool, rotate the hex bolt head CW to draw plus nut flanges up (set the plusnut).

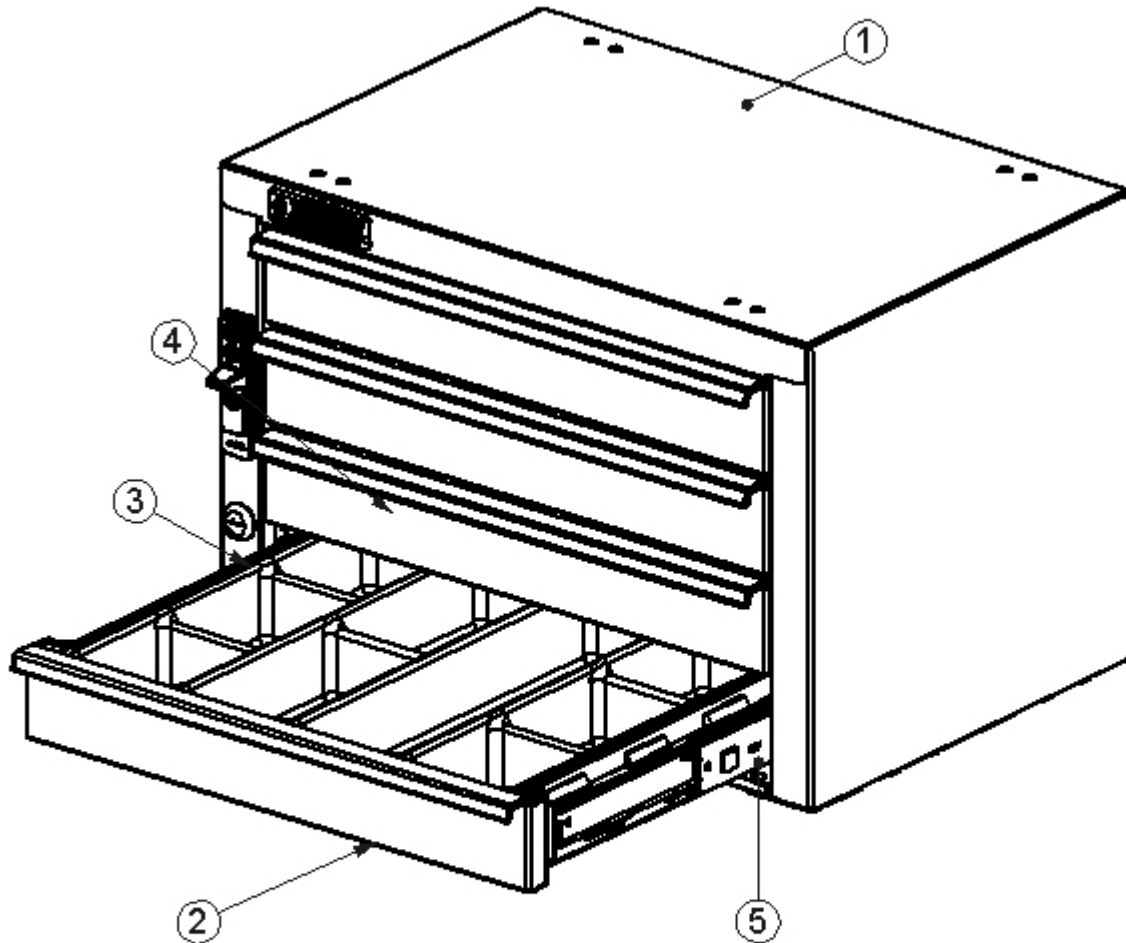

INSERT FOUR (4) 40287-LH AND FOUR (4) 40287-RH SLIDES INTO CABINET BODY. INSERT FOUR(4) 40015 DRAWERS INTO CABINET BODY. INSERT A TOTAL OF FOUR (4) 26105-0 DIVIDER TRAYS INTO UNIT. INSERT ONE (1) DIVIDER TRAY UPSIDE DOWN INTO TOP DRAWER AND RIGHT SIDE UP INTO THE REMAINING THREE (3) DRAWERS. PLACE BAG00001-0 INTO THE SECOND DRAWER TRAY. TAPE THE LOCK KEYS INTO THE FRONT RIGHT HAND TRAY POCKET AND CLOSE THE DRAWERS.

ITEM NO.	PART NUMBER	DESCRIPTION	BAG 00001-0/QTY.
1	BAG0505-A	5" x 5" 3MIL AUTOBAG	1
2	FAS 0066	Washer, Lock, Ext. Tooth, 1/4	4
3	FAS0520	Screw, Truss Hd. Ph, 1/4-20x .375" lg	4

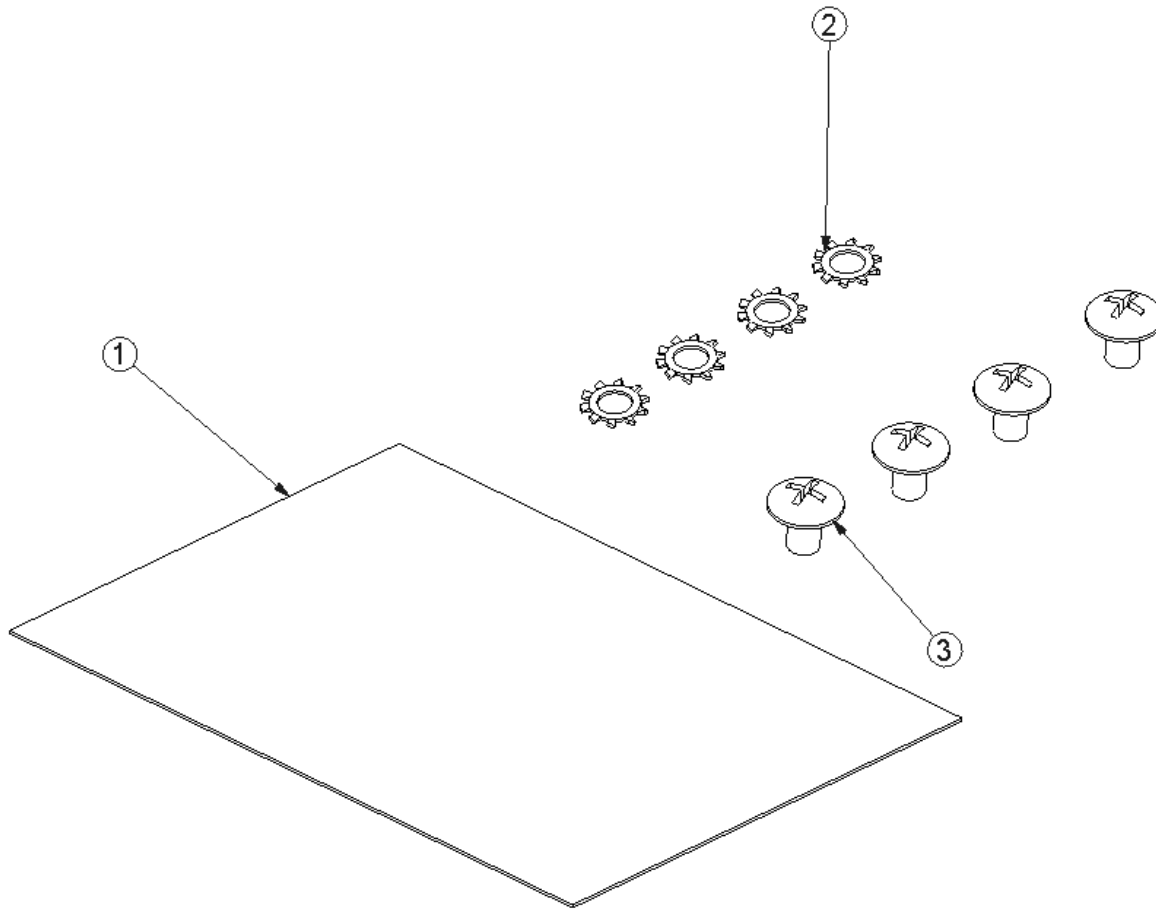

Individual Fastener Images & Descriptions

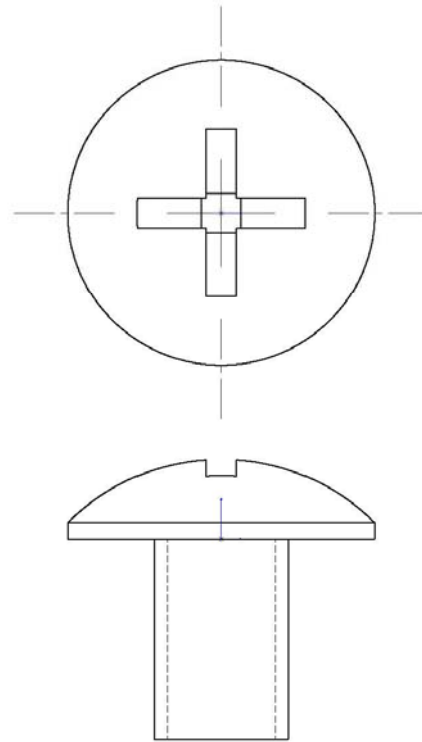
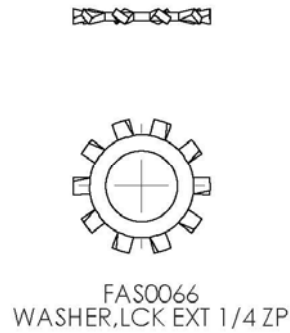

FAS0520
SCREW,THP 1/4-20 X .38
ZP

Step 01 Methods of Attachment

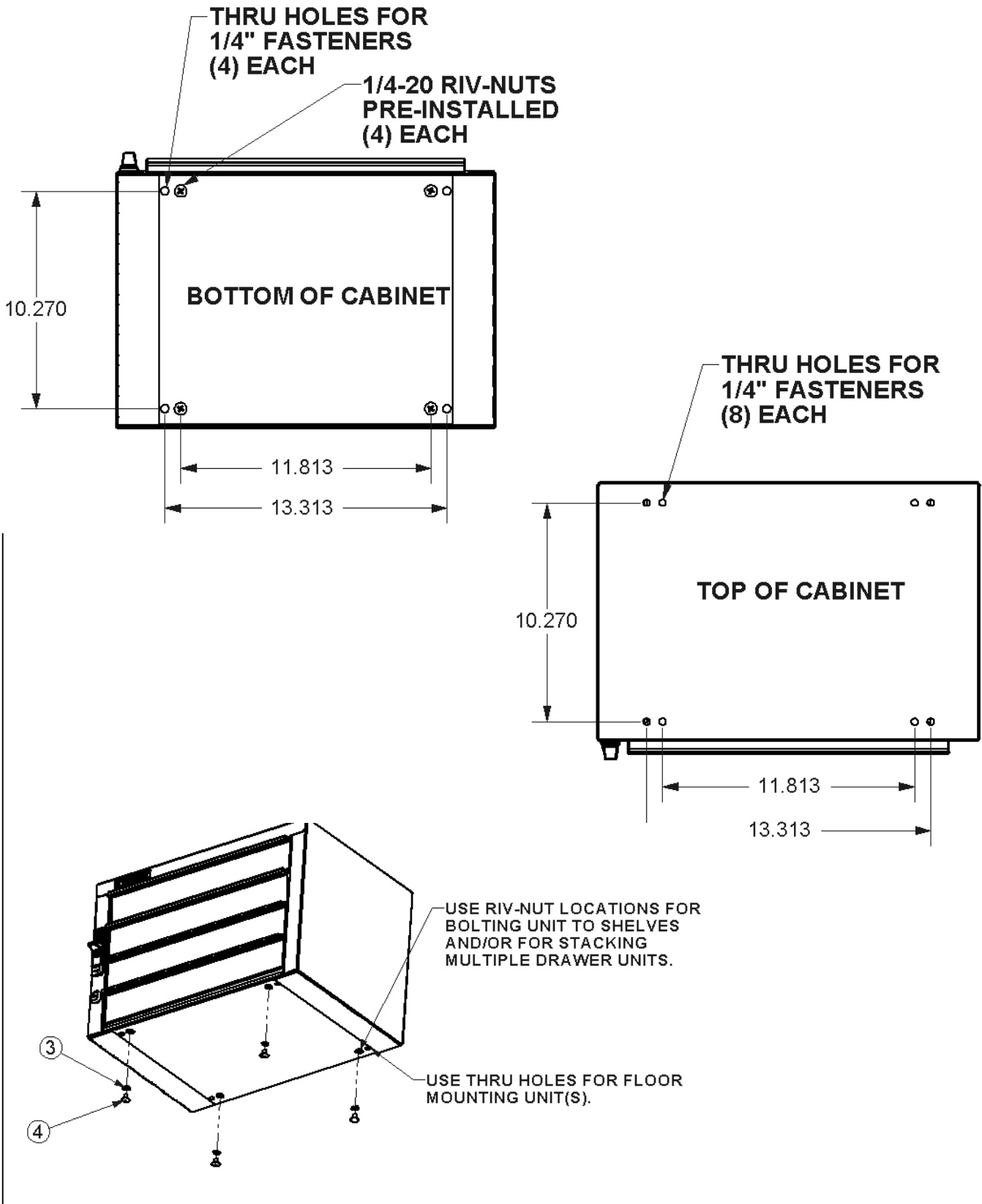

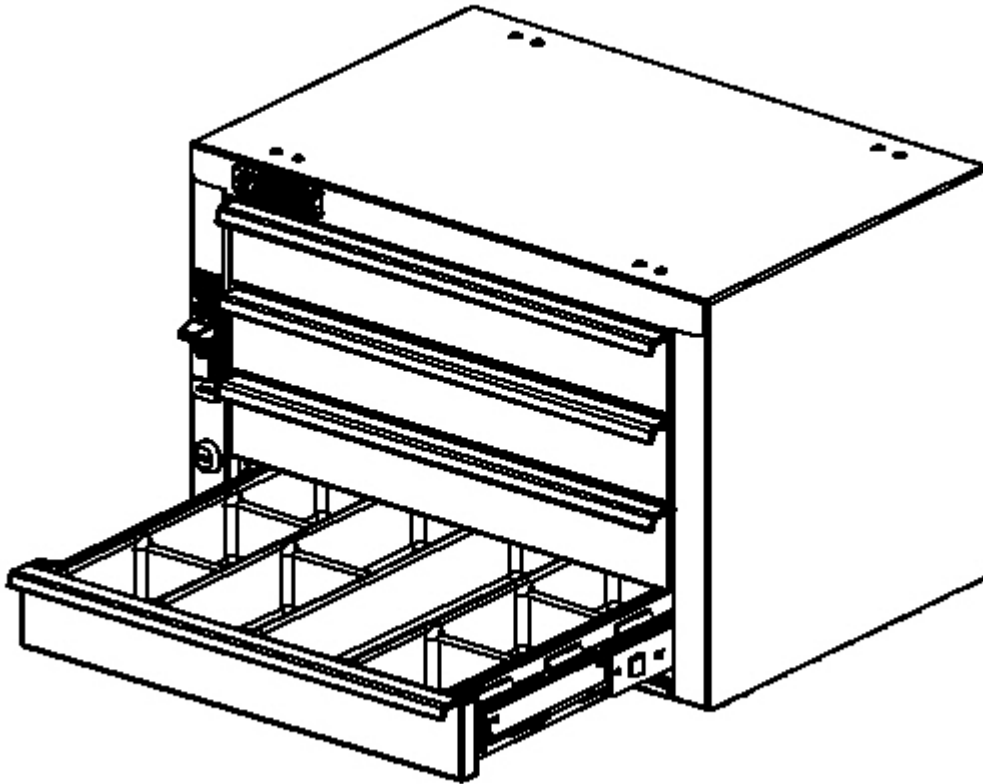

**DOUBLE CHECK ALL FASTENERS LOCATIONS TO BE SURE THAT ALL
FASTENERS ARE TIGHTENED TO SPECIFICATIONS.
YOUR INSTALLATION IS NOW COMPLETE!
STOW THIS COPY IN THE VEHICLE FOR FUTURE REFERENCES!**