



ADRIAN STEEL
VAN AND PICKUP EQUIPMENT

Z-RAIL KIT

Installation Instructions

****FOR Z-RAIL LENGTHS 18" – 60"*****

P.N.: 32298-0

ISSUE: C

CHK.BY: TW

REV.BY: DCS

DWG.BY: CRR

DATE: 11-29-2006

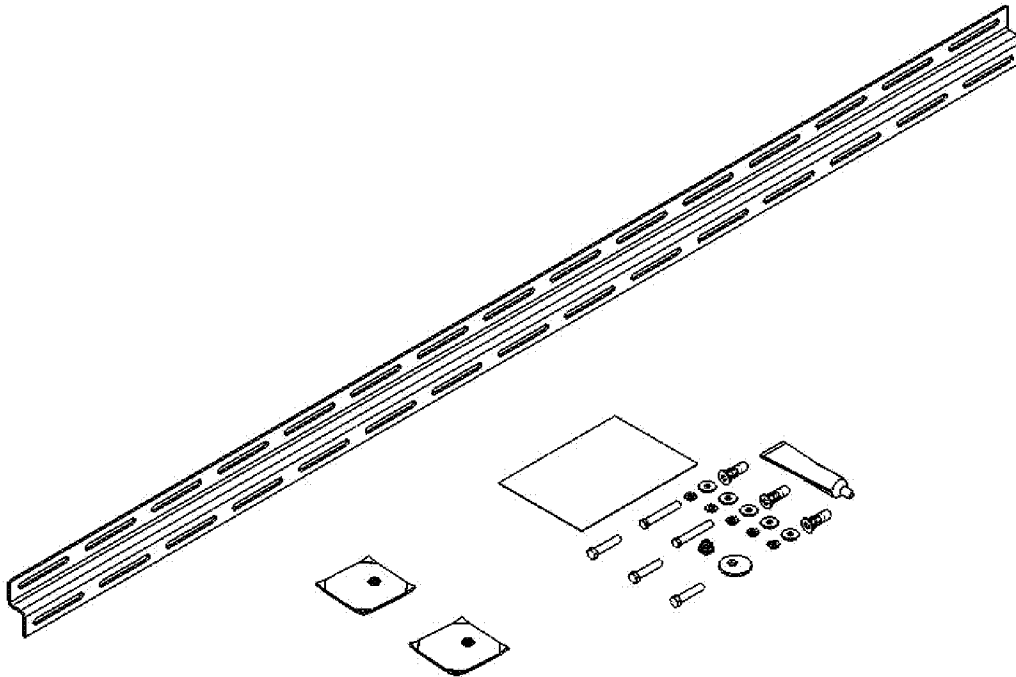



Z-RAIL KIT

BEFORE YOU START



IMPORTANT NOTES PERTAINING TO USER AND/OR PRODUCT SAFETY ARE DENOTED BY A STOP SIGN AND THEY MUST BE FOLLOWED IN ORDER TO COMPLETE A SAFE ASSEMBLY AND INSTALLATION!



YOU WILL NEED THE FOLLOWING TOOLS IN ORDER TO COMPLETE THIS JOB.

<p>DRILL MOTOR, WITH 3/8" DRILL BIT & 3/4" STOP</p>	<p>7/16" OPEN END WRENCH FOR SETTING PLUSNUTS</p>	<p>LONG LEVEL OR STRAIGHT EDGE</p>
<p>7/16" OPEN END WRENCH</p>	<p>RATCHET WRENCH, WITH 7/16" SOCKET WARNING: DO NOT USE IMPACT TOOLS FOR ASSEMBLY!</p>	

ALL FASTENERS USED IN THE ASSEMBLY AND INSTALLATION OF THIS PRODUCT SHOULD BE TIGHTENED TO A TORQUE OF 12 FT. LBS.



THE USE OF AIR OR ELECTRIC IMPACT TOOLS FOR THE ASSEMBLY OF FASTENERS IS NOT RECOMMENDED AND COULD CAUSE FASTENER FAILURE!



THE USE OF DRILLS WITH INTEGRAL DRILL STOPS IS STRONGLY RECOMMENDED TO ENSURE THAT VEHICLE DAMAGE IS AVOIDED!



FASTENER STANDARDS

- ❑ Proper fastening method of Adrian Steel products should always include good metal contact, using the supplied fasteners with prepackaged arrangements.
- ❑ A nut and bolt should always be used in all locations whenever possible.
- ❑ The use of plusnut(s) is intended for applications where a nut and bolt is not possible.
- ❑ All drilled holes in the vehicle should have the raw metal edges sealed to resist corrosion.



Important: To prevent exhaust fumes from entering the vehicle, all holes should be sealed at installation with Butyl or silicon sealant material, which will remain flexible for an extended period of time.



- ❑ Adrian Steel's blind fastener of choice is the plusnut. Adrian supplies two thread sizes, 1/4-20 and 5/16-18. 5/16-18 fasteners are used only as directed.
- ❑ After locating all positions that require a plusnut, drill the proper size hole (use a drill stop!) for the plusnut. A 1/4-20 plusnut uses 3/8" diameter drill (all locations), and the 5/16-18 uses 1/2" diameter drill (floor only).

FOR MOUNTING THROUGH A FLOOR MAT AND/OR CARPET

- ❑ Position each item in desired location inside the vehicle.



Important: Before marking each location with a center punch, move the item/jig and check for obstructions or hazards under the vehicle floor.



- ❑ Mark the floor mount locations.
Note: If a number of similar installations are being performed, it is recommended that a drilling template be used to ensure all installations are the same.
- ❑ Using the cutting tool, drill a pilot hole thru the mat/carpet and metal floor pan.
- ❑ ***The location of various floor mounts will determine what spacer combination will be used. For example, an 11/32" spacer is used atop floor ribs, and an 11/16" high spacer is used atop floor valleys.***



Note: The proper use of spacers is required when mounting over mat/carpet to ensure the metal-to-metal clamp-up, which will minimize component shifting in stressed conditions.



- ❑ Complete your installation using the additional instructions supplied with the equipment.



FASTENER STANDARDS cont'd.

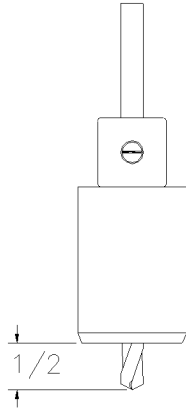

Placing the properly sized spacer on top of the vehicle floor pan will make your Adrian interior level, square, and sound. The view below shows the proper sized spacer for the different heights of the vehicle floor. Make sure to place the spacers with the plusnut relief surface down as shown.

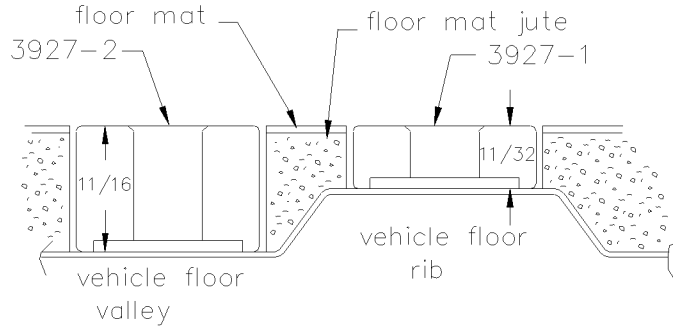

Plusnut Use and Installation

ASSEMBLE THE FOLLOWING

- 1) SETTING BOLT
1/4-20 x 2" LONG
OR
5/16-18 x 2-1/4"
 - 2) PLUSNUT TOOL
 - 3) PLUSNUT
- PLUSNUT TOOL
- PLUSNUT
1/4-20
OR
5/16-18

SETTING THE PLUSNUT

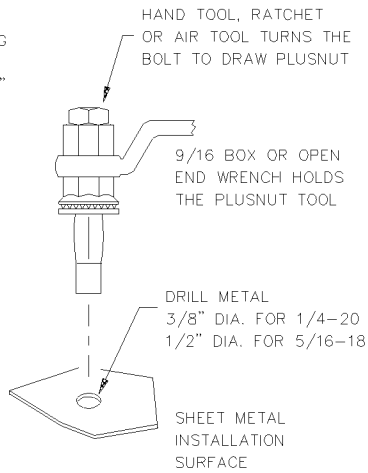

Set Plusnut till tight,
DO NOT OVERTIGHTEN.

Spacer Use and Installation

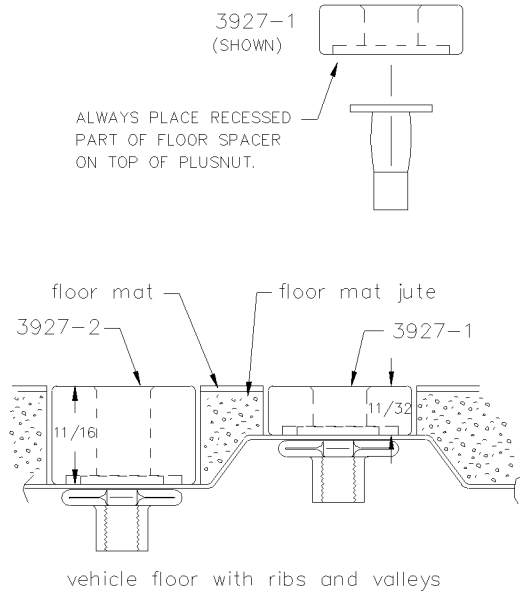



ADRIAN STEEL

VAN AND PICKUP EQUIPMENT



Z-RAIL KIT

STEP – 01

ATTACH Z-RAIL TO PRODUCT – PART 1

NOTE: IF YOU ARE NOT ATTACHING THE Z-RAIL TO A KD UNIT, SKIP THIS STEP AND REFER TO STEP 07 .

FASTENERS NEEDED FOR THIS STEP:

 <p>FAS0061 1/4-20 x 1/2" SCREW (2) REQUIRED</p>	 <p>FAS0055 1/4-20" NUT (2) REQUIRED</p>
--	--

THE Z-RAIL IS INTENDED TO BE PRODUCT WIDTH SPECIFIC. FOR EXAMPLE, A 32" LONG Z-RAIL SHOULD BE USED WITH A 32" WIDE CABINET/SHELF (I.E., HD 32 WP). DEPENDING ON THE INSTALLATION AND LAYOUT, A LONGER Z-RAIL CAN BE USED WITH A NARROWER CABINET/SHELF, HOWEVER *THE Z-RAIL SHOULD NEVER BE INSTALLED WITH A NARROWER CABINET/SHELF (I.E., 32" LONG Z-RAIL WITH A HD 52 WP)!*



Z-RAIL KIT

- 1) AFTER CABINET/SHELF ASSEMBLY, POSITION THE Z-RAIL TO TOP, BACKSIDE OF CABINET/SHELF, AS SHOWN IN FIGURE 1.

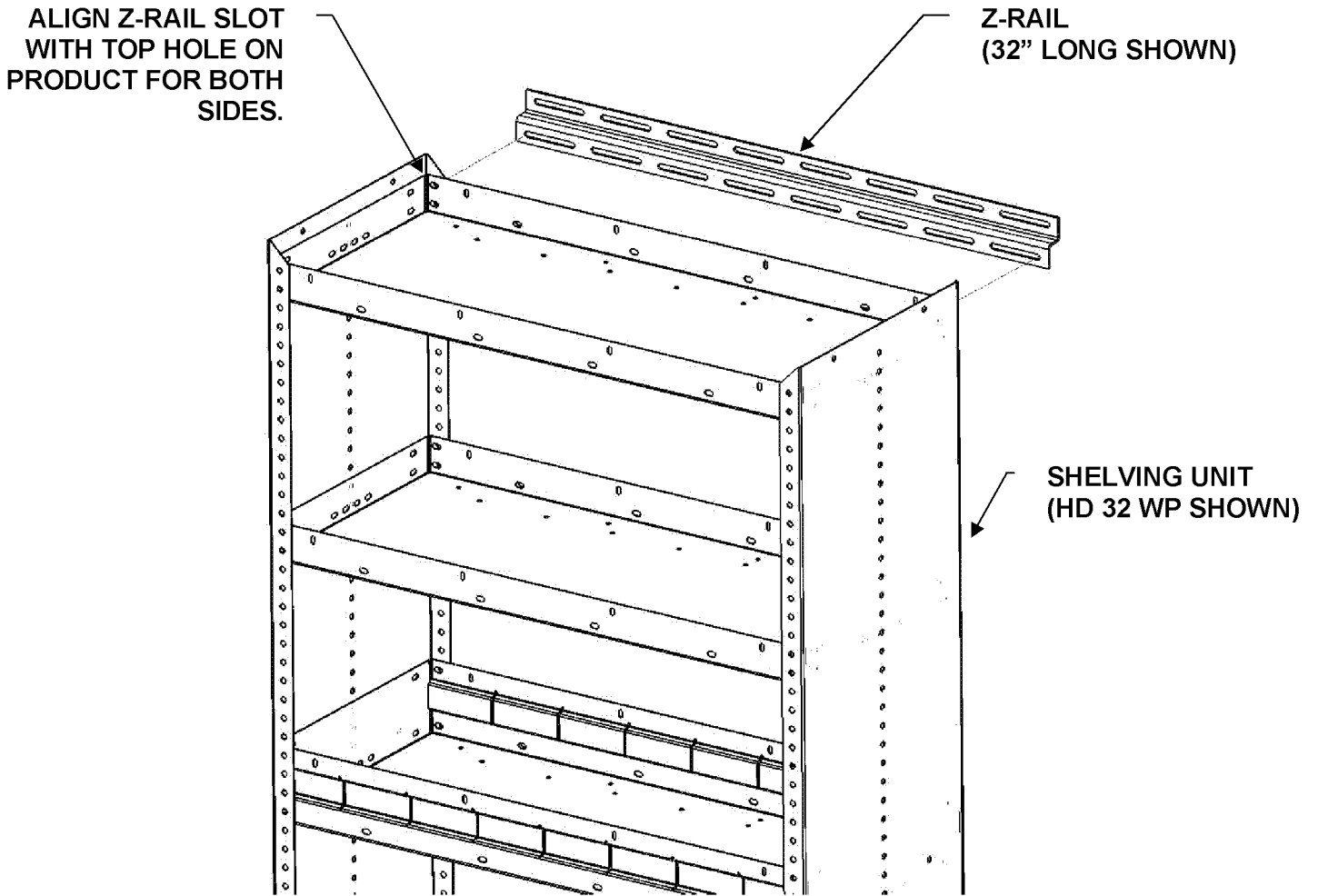

FIGURE 1. Z-RAIL PLACEMENT ON PRODUCT (KD UNIT SHOWN).



Z-RAIL KIT

- 2) USING THE 1/4-20 X 1/2" SCREWS AND NUTS, FASTEN BOTH ENDS OF Z-RAIL TO PRODUCT, AS SHOWN IN FIGURE 2.

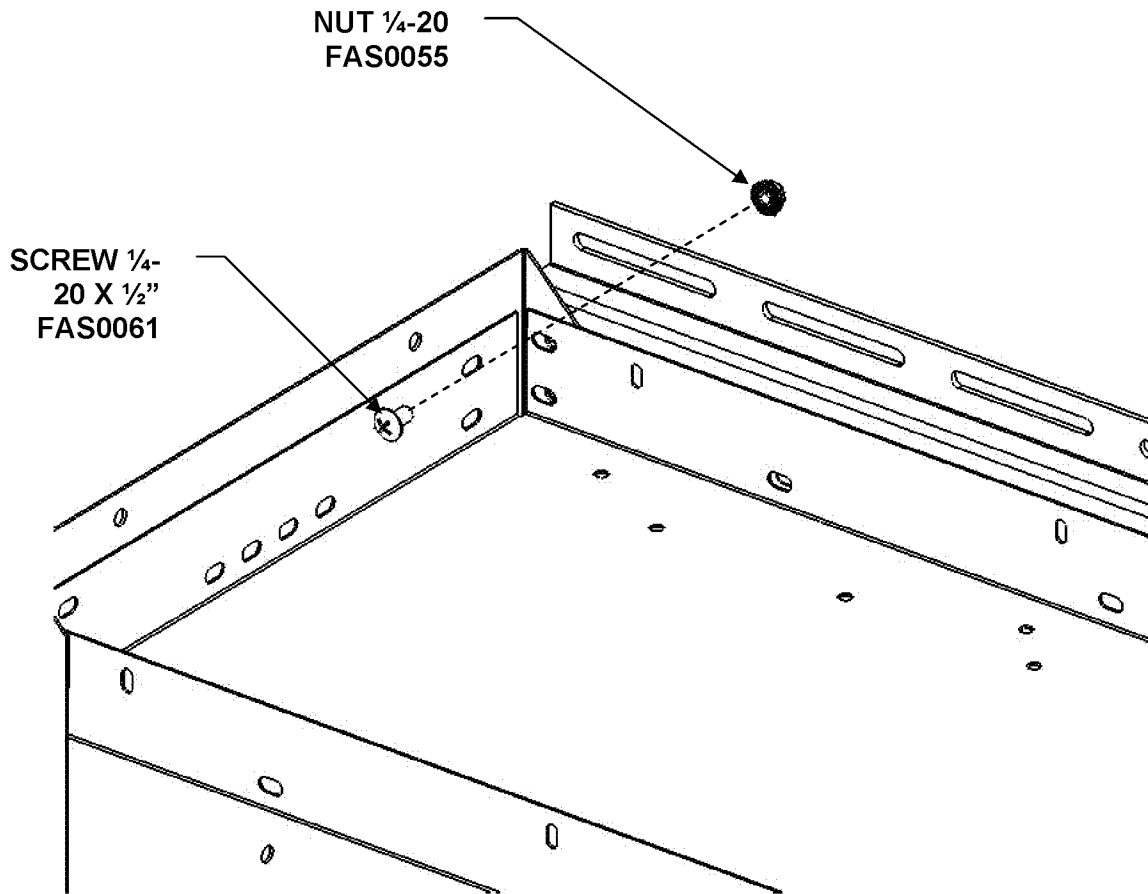

FIGURE 2. Z-RAIL FASTENING TO PRODUCT. ATTACH AS SHOWN TO BOTH SIDES.



STEP – 02

PRODUCT & Z-RAIL INSTALLATION – PART 1

FASTENERS NEEDED FOR THIS STEP:

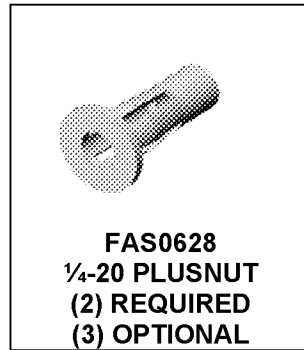

- 1) POSITION PRODUCT IN TRAILER AT THE DESIRED LOCATION.
- 2) VISUALLY INSPECT THE TRAILER INTERIOR AND LOCATE THE STEEL STUD MEMBERS DIRECTLY BEHIND THE PRODUCT TO BE INSTALLED.

HELPFUL NOTE: STEEL STUD MEMBERS CAN BE DETERMINED FROM THE INTERIOR OF TRAILER BY LOCATING SCREWS USED TO ATTACH PLYWOOD SHEET WALLS. NOTE THAT STUDS ARE LOCATED ON 16" CENTERS.

- 3) USING A LEVEL (OR OTHER LONG STRAIGHT EDGE), MARK A VERTICAL LINE ON THE PLYWOOD USING THE FURTHEST MOST SCREWS AT EACH END OF THE LEVEL. (THIS WILL DETERMINE THE "STUD LINE.") REPEAT FOR ALL REMAINING STUD MEMBERS DIRECTLY BEHIND THE PRODUCT TO BE INSTALLED.
- 4) POSITION THE PRODUCT UP AGAINST THE WALL SO THAT THE SLOTTED Z-RAIL FLANGE IS SEATED FLUSH AGAINST THE INTERIOR PLYWOOD WALL.

IMPORTANT NOTE: TRAILER INTERIOR PLYWOOD WALLS CONSIST OF SEVERAL SHEETS TO COVER ENTIRE WALL SURFACE AREA. THE SEAMS OF THE PLYWOOD JOINTS ARE TYPICALLY CONCEALED WITH NARROW 1/4" WOOD STRIPS. DO NOT SET PLUSNUTS THROUGH THESE STRIPS! REMOVE ANY STRIPS IN CONTACT WITH THE Z-RAIL BY SCORING WITH A UTILITY KNIFE AND REMOVING.

- 5) STARTING ON EITHER END OF THE Z-RAIL, MARK WHERE ALL PREVIOUSLY MARKED STUD LINES INTERSECT Z-RAIL SLOTS. FOR AN IDEAL INSTALLATION, THE STUD LINES SHOULD INTERSECT THE TWO OUTER MOST SLOTS OF THE Z-RAIL. DEPENDING ON INTERIOR LAYOUT LIMITATIONS, INNER SLOTS ARE ACCEPTABLE. HOWEVER, IF INNER SLOTS CAN ONLY BE USED, *THREE PLUSNUT SETTINGS AND FASTENERS SHOULD BE USED TO INSTALL THE PRODUCT. (SEE FIGURE 3.)*

HELPFUL NOTE: DEPENDING ON INTERIOR LAYOUT, THE PRODUCT CAN BE SHIFTED SIDE-TO-SIDE TO ACHIEVE IDEAL FASTENING POINTS.



ADRIAN STEEL

VAN AND PICKUP EQUIPMENT

Z-RAIL KIT

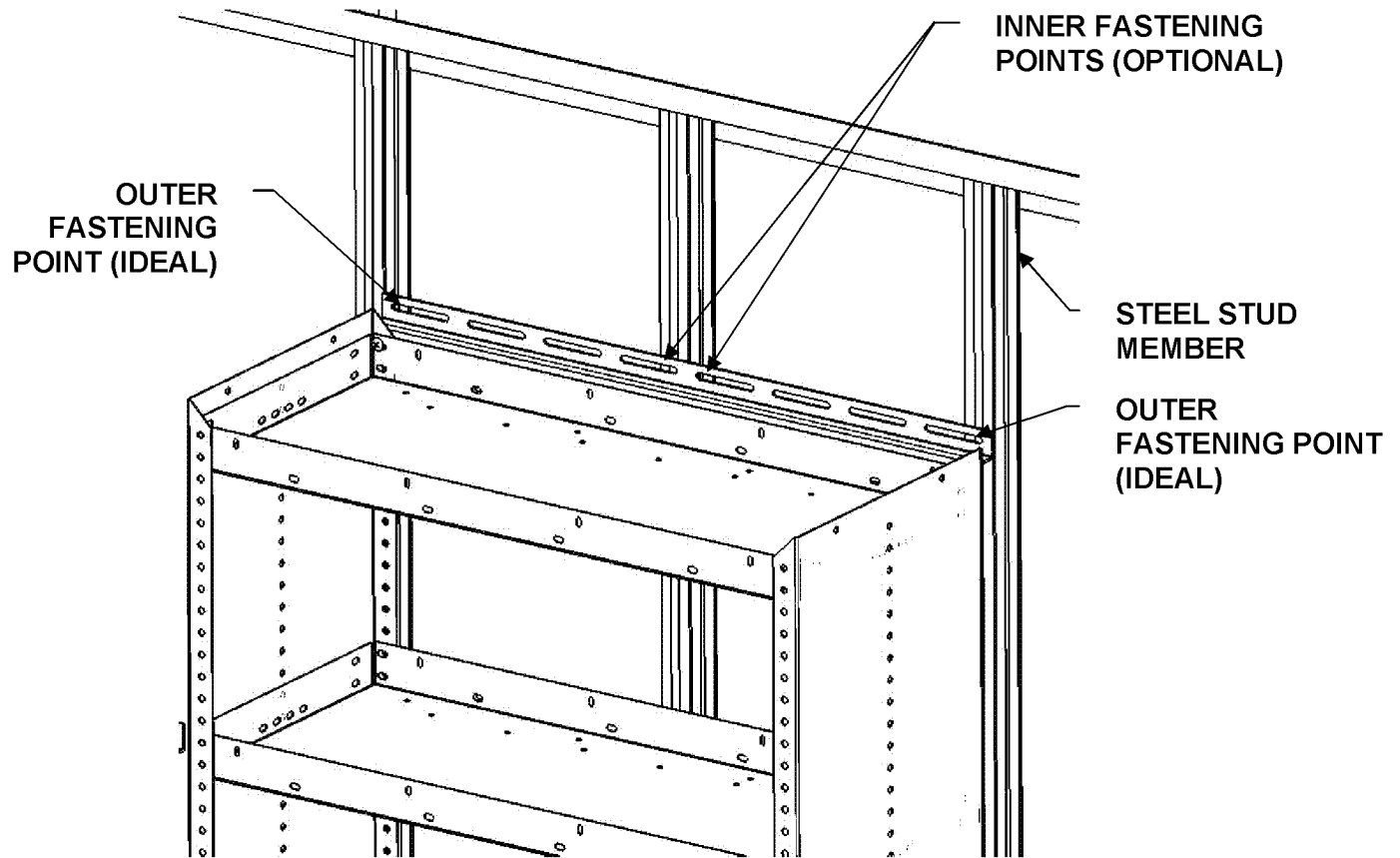

FIGURE 3. STUD LINE DETERMINATION. (INTERIOR PLYWOOD WALL REMOVED FROM FIGURE FOR STEEL STUD MEMBER VISIBILITY.)

- 6) AFTER STUD MEMBER FASTENING POINTS HAVE BEEN DETERMINED, TEMPORARILY MOVE PRODUCT AWAY FROM WALL. USING A DRILLMOTOR WITH 3/8" BIT & 3/4" STOP, DRILL THROUGH PLYWOOD SHEET AND STEEL STUD MEMBER AT ALL MARKED FASTENING POINTS.
- 7) MOVE PRODUCT BACK AGAINST WALL TO DESIRED LOCATION. RE-CHECK FASTENING POINTS, AND MOVE PRODUCT SIDE-TO-SIDE IF NECESSARY.
- 8) SET PLUSNUTS PER THE STANDARDS OUTLINED ON PAGES 3 & 4 OF THESE INSTRUCTIONS.



**DO NOT MOUNT PRODUCT TO WALL AT THIS POINT!
PROCEED TO NEXT STEP**





STEP – 03

FLOOR MOUNTING – PART 1

- 1) WITH THE PRODUCT AGAINST INTERIOR PLYWOOD WALL AT THE DESIRED LOCATION, MARK THE PLYWOOD TRAILER FLOOR THROUGH THE FRONT, OUTER HOLES ON PRODUCT, AS SHOWN IN FIGURE 4.

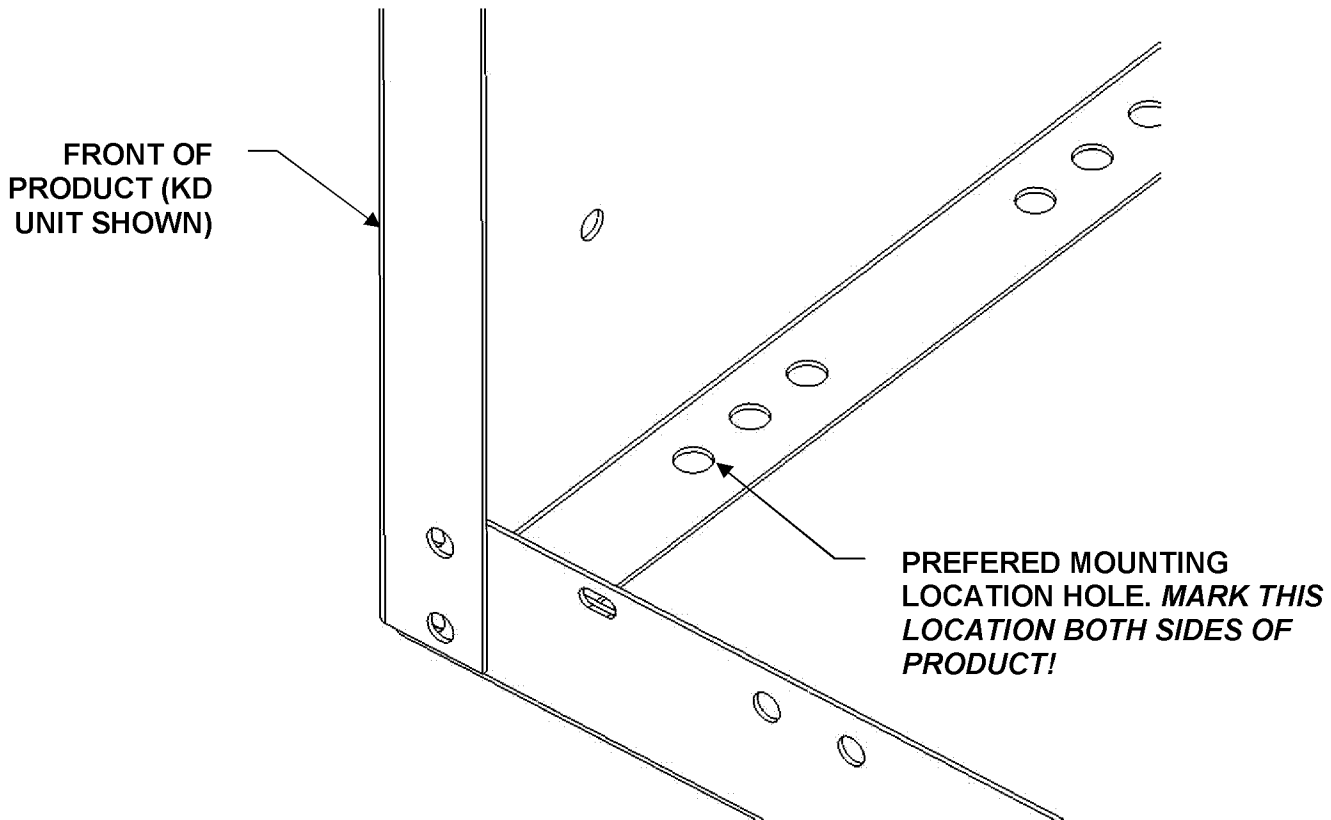

FIGURE 4. FLOOR MOUNTING LOCATIONS.

- 2) TEMPORARILY MOVE THE PRODUCT AWAY FROM THE WALL. USING A DRILLMOTOR WITH A 1/2" BIT, DRILL THROUGH PLYWOOD FLOOR AT BOTH MARKED POINTS.

NOTE: IF A STEEL FLOOR STRUCTURAL MEMBER IS PRESENT IN DRILLING LOCATION, SKIP TO STEP 06.

- 3) MOVE PRODUCT BACK AGAINST WALL TO PRE-DETERMINED LOCATION.



**DO NOT MOUNT PRODUCT TO FLOOR AT THIS POINT!
PROCEED TO NEXT STEP**







STEP – 04

PRODUCT & Z-RAIL INSTALLATION – PART 2

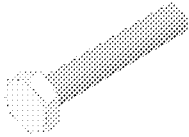
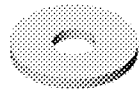
FASTENERS NEEDED FOR THIS STEP:

 <p>FAS0079 1/4-20 x 1-1/2" HH (2) REQUIRED (3) OPTIONAL</p>	 <p>FAS0067 1/4" FLAT WASHER (2) REQUIRED (3) OPTIONAL</p>	 <p>FAS0060 1/4" SPLIT LOCKWASHER (2) REQUIRED (3) OPTIONAL</p>
--	--	---

- 1) WITH THE PRODUCT AGAINST WALL AT PRE-DETERMINED LOCATION, NOTE ALL FASTENING POINTS. *ENSURE THAT ALL FLOOR & WALL MOUNTING POINTS ADEQUATELY LINE-UP.* NEXT, FASTEN Z-RAIL TO WALL, AS SHOWN IN FIGURE 5.

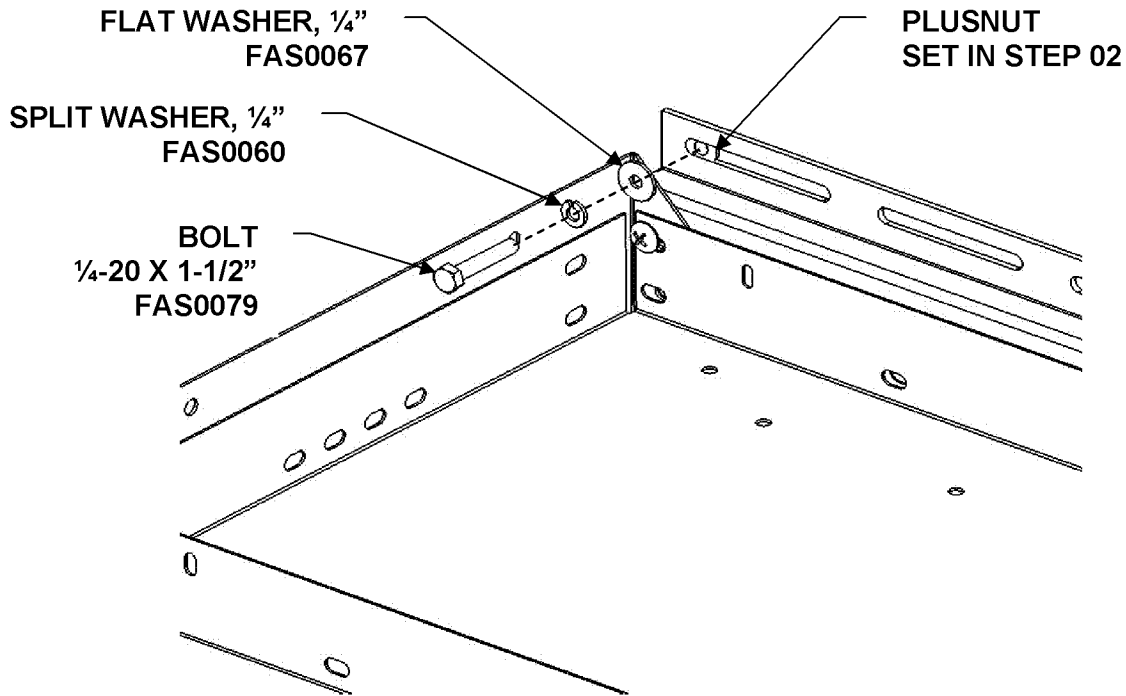

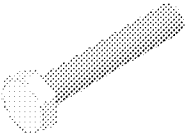



FIGURE 5. Z-RAIL FASTENING.



STEP – 05

FLOOR MOUNTING – PART 2

FASTENERS NEEDED FOR THIS STEP:

			
<p>FAS0080 1/4-20 x 2" HH (2) REQUIRED</p>	<p>FAS0067 1/4" FLAT WASHER (2) REQUIRED</p>	<p>FAS0060 1/4" SPLIT LOCKWASHER (2) REQUIRED</p>	<p>32239-0 MOUNTING PLATE (2) REQUIRED</p>

- 1) WITH PRODUCT SECURELY MOUNTED TO WALL, AS ILLUSTRATED IN STEP 04, INSERT FASTENERS THROUGH FLOOR, AS SHOWN IN FIGURE 6.

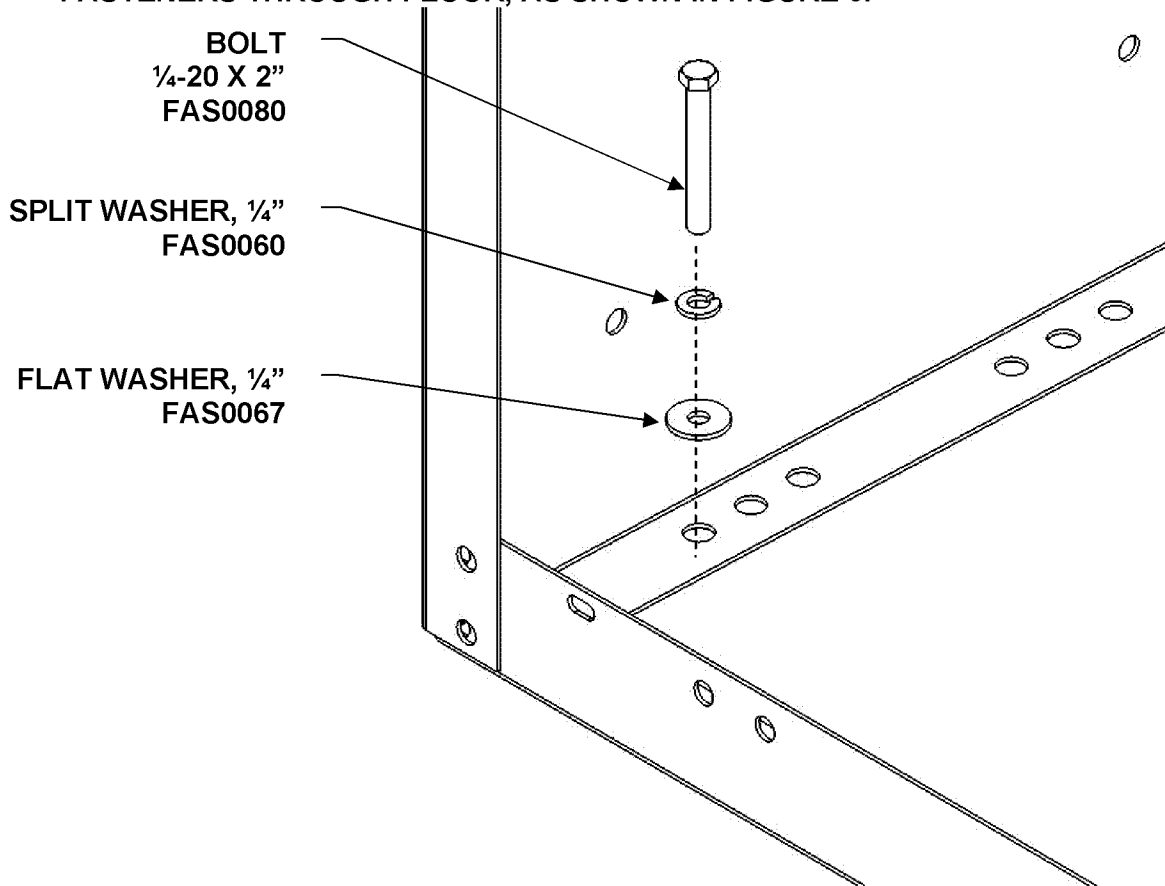

FIGURE 6. FLOOR MOUNTING FASTENERS.



- 2) APPLY SILICONE SEALANT (INCLUDED) FULLY AROUND THE PERIMETER TO ONE SIDE OF EACH MOUNTING PLATE, AS SHOWN IN FIGURE 7.

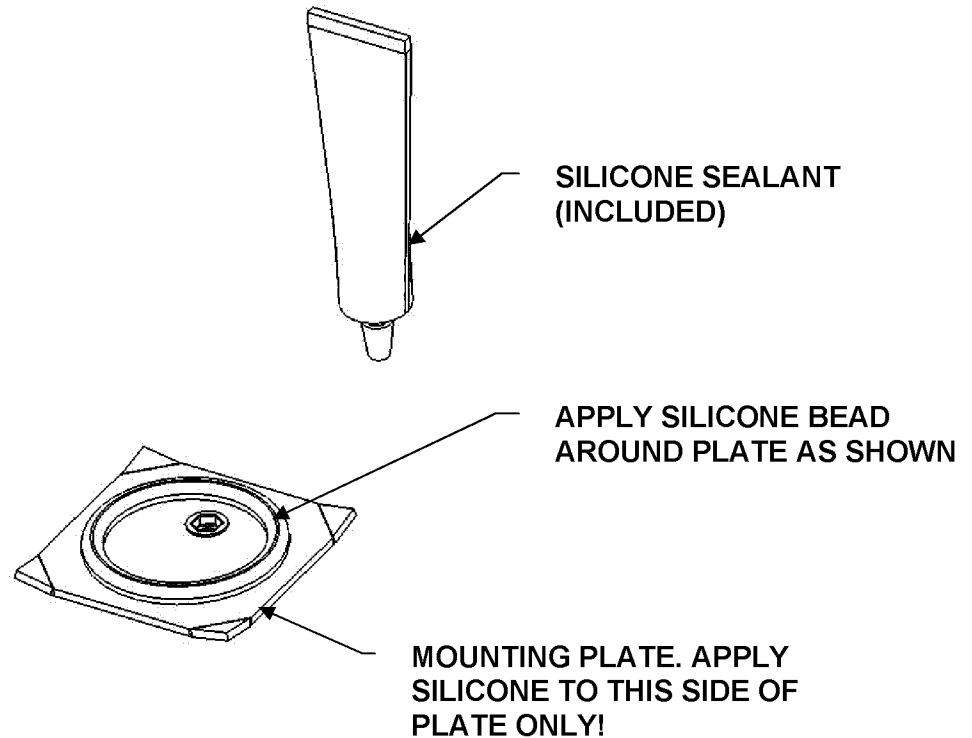

FIGURE 7. SILICONE SEALANT APPLICATION TO MOUNTING PLATE.

- 3) GO BENEATH TRAILER TO PRODUCT BEING INSTALLED. LOCATE THE TWO BOLTS PETRUDING THROUGH THE FLOOR. SCREW THE MOUNTING PLATES ON THE BOLTS UNTIL THE SHARP CORNERS OF THE MOUNTING PLATES "BITE" THE UNDERSIDE OF PLYWOOD FLOOR.



HELPFUL NOTE: IT MAY BE NECESSARY TO HOLD THE BOLT END WITH ONE HAND WHILE APPLYING A DOWNWARD FORCE TO PREVENT THE BOLT FROM SPINNING WHILE MOUNTING PLATE IS THREADED UP TO PLYWOOD FLOOR.

- 4) GO BACK TO TRAILER INTERIOR AND SECURELY TIGHTEN THE FLOOR FASTENERS AS OUTLINED ON PAGES 2 THROUGH 4 OF THESE INSTRUCTIONS.

**STEP – 06****FLOOR MOUNTING – PART 3**

NOTE: IF YOU DID NOT ENCOUNTER A STEEL FLOOR STRUCTURAL MEMBER, SKIP THIS STEP.

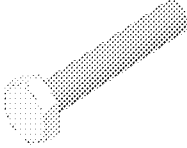
FASTENERS NEEDED FOR THIS STEP:

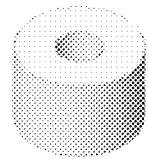
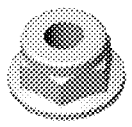
 <p>FAS0634 1/4-20 x 2-1/2" HH (1) REQUIRED</p>	 <p>FAS0067 1/4" FLAT WASHER (1) REQUIRED</p>	 <p>FAS0060 1/4" SPLIT LOCKWASHER (1) REQUIRED</p>	 <p>SPACER 11/16" (1) REQUIRED</p>	 <p>NUT, NYLOCK 1/4-20 (1) REQUIRED</p>
---	---	--	---	---

COMMON TRAILER STEEL FLOOR STRUCTURAL MEMBERS ARE EITHER "Z" CHANNELS OR "C" CHANNELS. WHICHEVER CHANNEL IS APPLICABLE TO YOUR INSTALLATION, MOUNTING TO THE CHANNEL FLANGE MAY BE NECESSARY. TRAILER STEEL FLOOR CHANNELS ARE TYPICALLY LOCATED ON 24" CENTERS. *THIS STEP ASSUMES THAT THE INSTALLER HAS ALREADY DRILLED THROUGH THE TRAILER PLYWOOD FLOOR UPON DETECTION OF THE STEEL CHANNEL.*

- 1) WITH A DRILL MOTOR AND 1/2" DRILL BIT, DRILL THROUGH THE STEEL CHANNEL FLANGE.
- 2) WITH A DRILL MOTOR AND 1" HOLE SAW, BORE PLYWOOD FLOOR TO STEEL FLANGE.
- 3) APPLY A GENEROUS BEAD OF SILICONE SEALANT (INCLUDED) ALONG THE BOTTOM OF THE HOLE. *(IMPORTANT: THIS WILL SEAL THE EXPOSED PLYWOOD FROM PENETRATING MOISTURE THROUGH TRAILER UNDERCARRIAGE!)*
- 4) PLACE 11/16" SPACER IN HOLE AND POSITION PRODUCT TO BE INSTALLED IN DETERMINED LOCATION.
- 5) INSERT FASTENERS THROUGH FLOOR AS SHOWN PREVIOUSLY IN FIGURE 6.
- 6) GO BENEATH TRAILER TO THE LOCATION WHERE THE PRODUCT IS BEING INSTALLED. LOCATE THE BOLT PROTRUDING THROUGH THE STEEL CHANNEL FLANGE.
- 7) ATTACH FASTENERS AS SHOWN IN FIGURE 7 AND SECURE PER FASTENER STANDARDS AS OUTLINED ON PAGES 2 & 3 OF THESE INSTRUCTIONS.

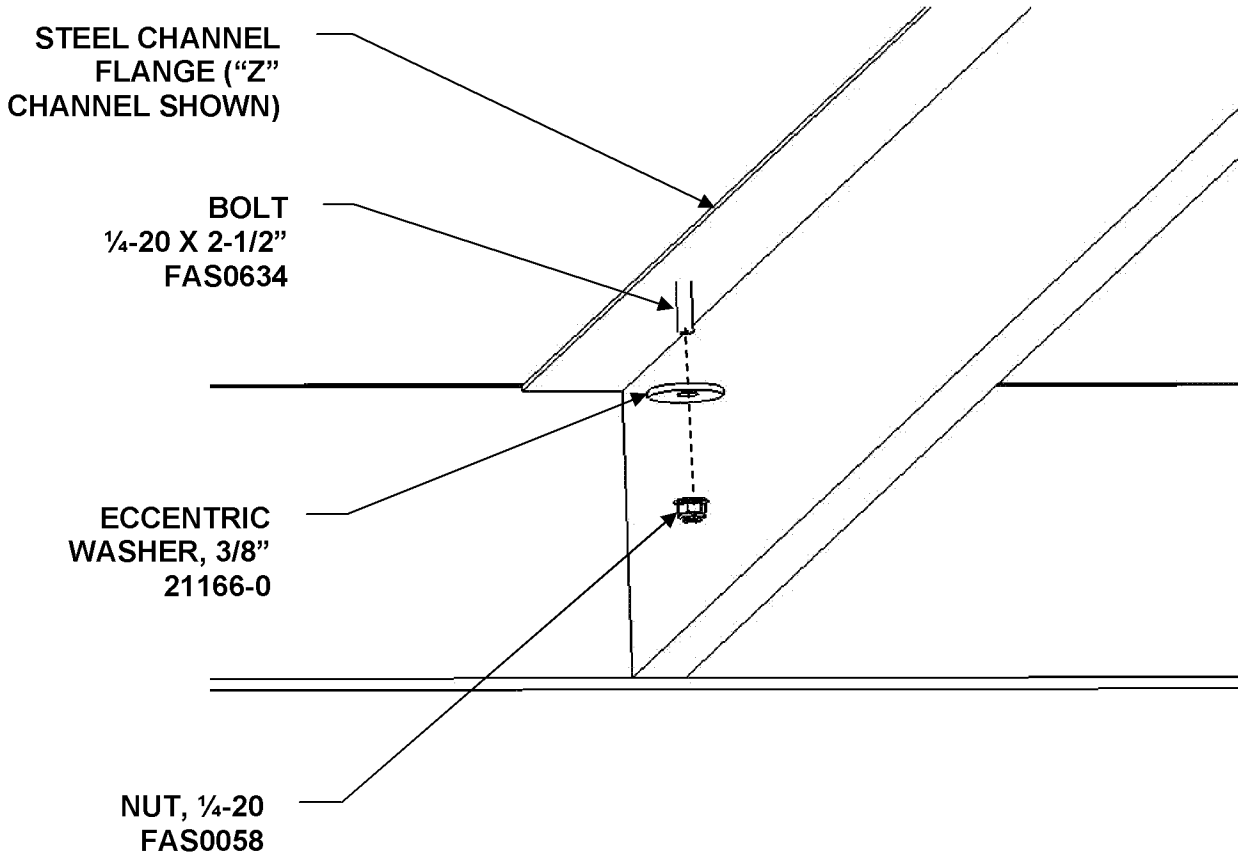

FIGURE 7. BOLT THROUGH STEEL CHANNEL FLANGE.



STEP - 07

Z-RAIL ACCESSORY HOOKS

NOTE: IF YOU DO NOT HAVE Z-RAIL ACCESSORY HOOKS, SKIP TO STEP 09.

DEPENDING ON YOUR STORAGE NEEDS, THE Z-RAIL HOOKS CAN BE PLACED IN THE Z-RAIL SLOTS INDIVIDUALLY (I.E., EXTENSION CORDS) OR IN MULTIPLES CONFIGURATIONS SIDE-BY-SIDE (I.E., BROOMS), AS ILLUSTRATED BELOW.

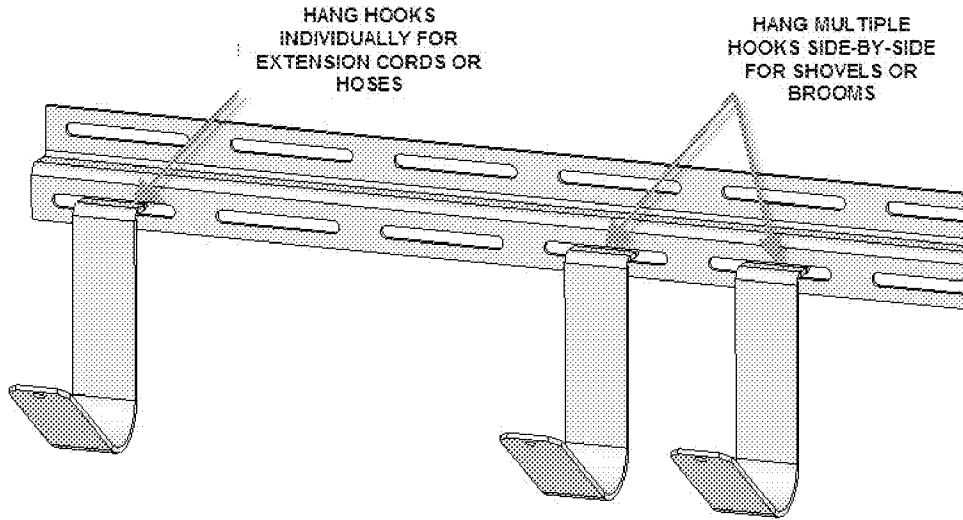

STEP - 08

HANG THE Z-RAIL HOOK

AS ILLUSTRATED BELOW, INSERT HOOK(S) THROUGH Z-RAIL SLOTS AT DESIRED LOCATIONS. AFTER INSERTING HOOK THROUGH Z-RAIL SLOT, "SWING" THE OPPOSITE HOOK END DOWNWARD TO ENGAGE.

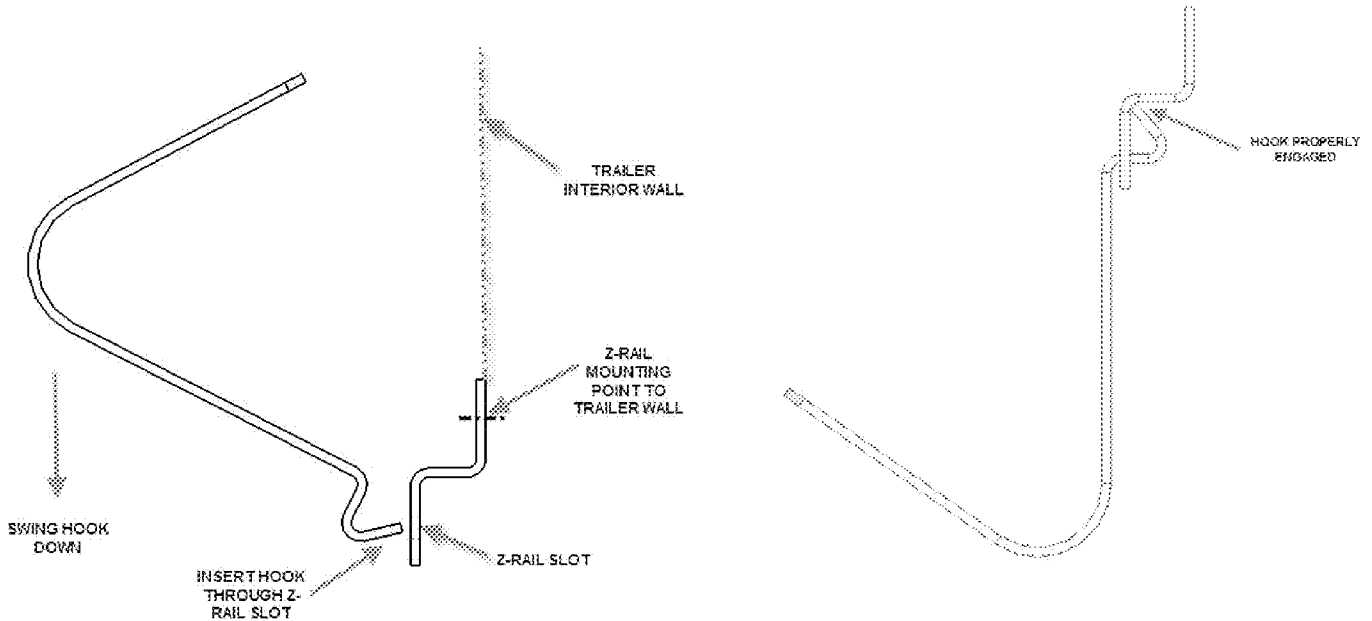



ADRIAN STEEL

VAN AND PICKUP EQUIPMENT

Z-RAIL KIT

STEP – 09

ADDITIONAL/OTHER PRODUCT INSTALLATION GUIDELINES

CARGO TRAILER UPFITS ARE RATED FOR THE EXPERIENCED INSTALLER. WITH PRODUCT AND INSTALLATION KNOWLEDGE LIBERTIES CAN BE TAKEN TO ACHIEVE A SECURE INSTALLATION. FOLLOW THESE GENERAL GUIDELINES WHEN INSTALLING ADDITIONAL/OTHER PRODUCT:

- 1) FOR ADDITIONAL SUPPORT, IT IS RECOMMENDED THAT ADJACENT PRODUCT BE THRU-BOLTED TOGETHER.**
- 2) WHEN INSTALLING MODULAR UNITS MD701T & MD702T, ATTACH Z-RAIL TO TRAY TOP IN THE SAME MANNER AS THE KD UNIT OUTLINED IN STEP 01 (DRILLING THE PRODUCT TO ATTACH THE Z-RAIL WILL BE REQUIRED).**
- 3) WHEN INSTALLING A WORKBENCH MODULE MD705T, DRILL CLEARANCE HOLES ON THE REAR TABLE TOP FLANGE AT THE THREE Z-RAIL SLOT LOCATIONS, THEN THROUGH BOLT AS OUTLINED IN STEP 01.**
- 4) WHEN INSTALLING TANK RACKS, THE Z-RAIL CAN BE USED IN CONJUNCTION WITH STANDARD STRAP BRACKETS ATTACHED TO THE PRODUCT. TANK RACKS CAN ALSO BE USED WITHOUT THE Z-RAIL BY BOLTING THROUGH FLOOR AND ADJACENT PRODUCT.**
- 5) WHEN INSTALLING CABINETS (NO FLOOR SUPPORT/MOUNTING) ATTACH THE Z-RAIL TO THE TOP AND BOTTOM OF CABINET (DRILLING THE PRODUCT TO ATTACH THE Z-RAIL WILL BE REQUIRED), THEN MOUNT BOTH Z-RAILS TO TRAILER STEEL STUD MEMBERS AS OUTLINED IN THESE INSTRUCTIONS.**

Introduction / Comments:

Note:

It is advised that all fasteners used in this assembly and installation should be checked for tightness at the following intervals: @ 2-weeks and again @ 6-weeks of operation. This preventive maintenance step must be completed to ensure your Product gives you long service life.

ITEM NO.	PART NUMBER	DESCRIPTION	MD4842T/ QTY.
1	SF42448	SHELF 4X24X48	2
2	VM42	VERTICAL MEMBER	2
3	VM14	ROLL FORM. 15472 14" VM	2
4	VM30	VERTICAL MEMBER	2
5	FR24	FLOOR RAIL 24"	4
6	FR48	FLOOR RAIL 48"	3
7	32237-0	Z-RAIL, 48"	1
8	FA12	Floor Angle 12"	2
9	HDWMD4842T	HARDWARE KIT FOR MD4842T	1

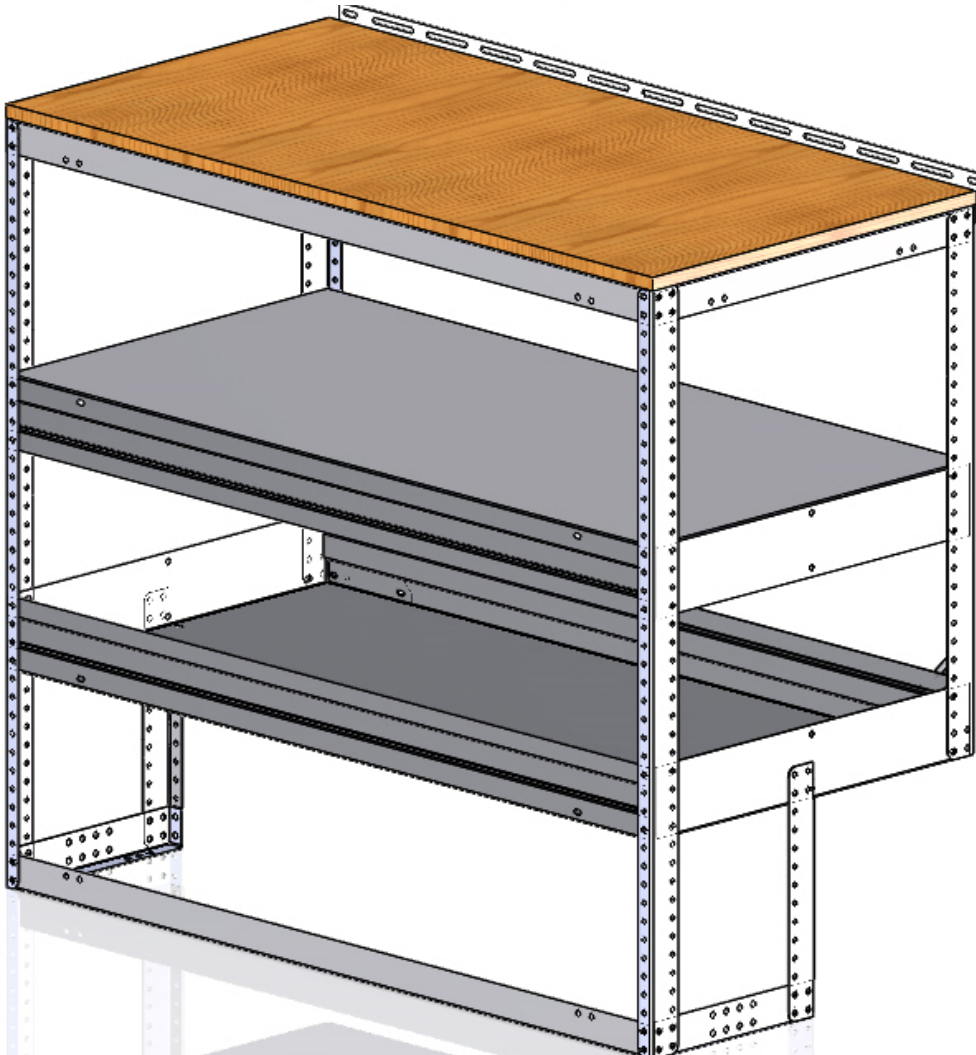

MD4842T

- PRECAUTIONS -



CAUTION
THE USE OF AIR IMPACT TOOLS CAN OVER-TORQUE FASTENERS AND CAUSE FASTENER FAILURE!



CAUTION
ALL INSTALLATION HOLES SHOULD BE SEALED WITH SILICON OR BUTYL SEALANT TO PREVENT EXHAUST FUMES FROM ENTERING THE VEHICLE!



DANGER
INSPECT FOR FUEL TANK, FUEL LINES, BRAKE LINES, HIGH VOLTAGE BATTERIES AND ELECTRICAL LINES PRIOR TO DRILLING TO AVOID DAMAGING CRITICAL VEHICLE SYSTEMS OR INJURY TO INSTALLER DURING INSTALLATION PROCESS!



CAUTION
TO AVOID DAMAGING THE VEHICLE ALWAYS USE DRILL STOPS WHEN DRILLING ANY INSTALLATION HOLES!
ADRIAN AVAILABLE PART #'S 31121-0 (3/8" X 1/2" DEEP), 31121-0 (1/2" x 1/2" DEEP)



- IMPORTANT WARRANTY REQUIREMENTS -

1. SUBSTITUTING ADRIAN STEEL SPECIFIED FASTENERS FOR ASSEMBLY AND/OR INSTALLATION WILL VOID YOUR PRODUCT WARRANTY.
2. ALL HOLES DRILLED INTO VEHICLE SHOULD HAVE THE RAW METAL EDGES SEALED WITH A SELF-ETCHING PRIMER TO RESIST CORROSION AND POTENTIAL FASTENER POINT FAILURE.
3. ALL FASTENERS USED IN THE INSTALLATION OF THIS PRODUCT SHOULD BE TIGHTENED TO THE TORQUE(S) SPECIFIED IN THESE INSTRUCTIONS.
4. THESE INSTRUCTIONS SHOULD BE KEPT WITH THE VEHICLE.

THE BASIC TOOLS NEEDED FOR MOST INSTALLATIONS



DRILL



DRILL BIT WITH STOP



RATCHET, SOCKETS AND/OR WRENCHES



SCREWDRIVERS



MEASURING TAPE

ADDITIONAL TOOLS MAY BE NEEDED FOR THIS INSTALLATION AND THEY WILL BE IDENTIFIED IN THE STEPS THAT FOLLOW.

If your vehicle contains carpet or a rubber floor mat you will need to prepare the mounting location. Position the product to be installed into the vehicle and once you are satisfied with the mounting locations, mark the mounting locations. Using a 1-3/16" diameter carpet cutter (P/N: 31183-0). Select the appropriate floor spacers as shown in the illustration. Set those aside for use later into the installation process.

Using the correct drill bit size for the selected plusnut, drill the mounting holes in the vehicle sheet metal to prepare for installing the plusnuts.

If you are thru-bolting at any of the locations simply drill a hole that is 1/16" larger than the bolt size(s) for those locations.

Once you have drilled the holes into the vehicle, the raw metal edges should be sealed using a self-etching primer to resist corrosion and potential fastener point failure.

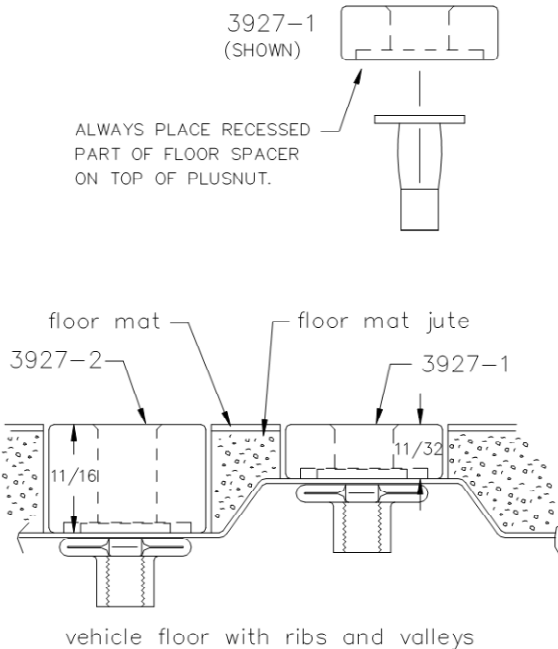

A PLUSNUT (RIVNUT) SETTING TOOL IS REQUIRED FOR PLUSNUT (RIVNUT) INSTALLATION . PLUS NUT SETTING TOOL CAN BE ORDERED THROUGH ADRIAN STEEL, OR USE AN AIR POWERED PLUSNUT SETTING GUN.

1/4-20UNC Plusnut (FAS0052) Use 3/8" dia. drill w/stop
 FAS0080 SCREW, HXHD, 1/4-20UNCx2.00", G8
 FAS0067 WASHER, FLAT, 1/4"ID
 22200-0 PLUSNUT TOOL

5/16-18UNC Plusnut (FAS0091) Use 1/2" dia. drill w/stop
 FAS0095 SCREW, HXHD, 5/16-18UNCx2.00", G8
 FAS0086 WASHER, FLAT, 5/16"ID
 22200-0 PLUSNUT TOOL

Place barrel of the plusnut body in sheet metal thru hole until flange is flush with sheet metal.
 Using a 9/16" combination wrench of plusnut tool body and a second hand wrench, ratchet, or air tool, rotate the hex bolt head CW to draw plus nut flanges up (set the plusnut).

Installation and/or Assembly Fasteners
BAG32223-0

ITEM NO.	PART NUMBER	DESCRIPTION	QTY.
1	FAS0079	Screw, Hex Hd, 1/4-20x1.50 Zn Plate, Grade 8	3
2	FAS0067	Washer, Flat, 1/4	5
3	FAS0060	Washer, Lock, Split, 1/4	5
4	FAS 0628 unclinched	Plusnut, 1/4-20, .250-.500 GRIP	3
5	BAG0507-A	5" x 7" 3MIL AUTOBAG	1
6	FAS0080	Screw, Hex Hd, 1/4-20x2.00 Zn Plate, Grade 8	2
7	FAS0058	Nut, Nylon Insert Lock, 1/4-20	1
8	21166-0	ECCENTRIC WASHER	1
9	26618-0	Silicone Sealant	1
10	03927-2	Floor Spacer Tall	1
11	32239-0	MOUNTING PLATE ASSY	2

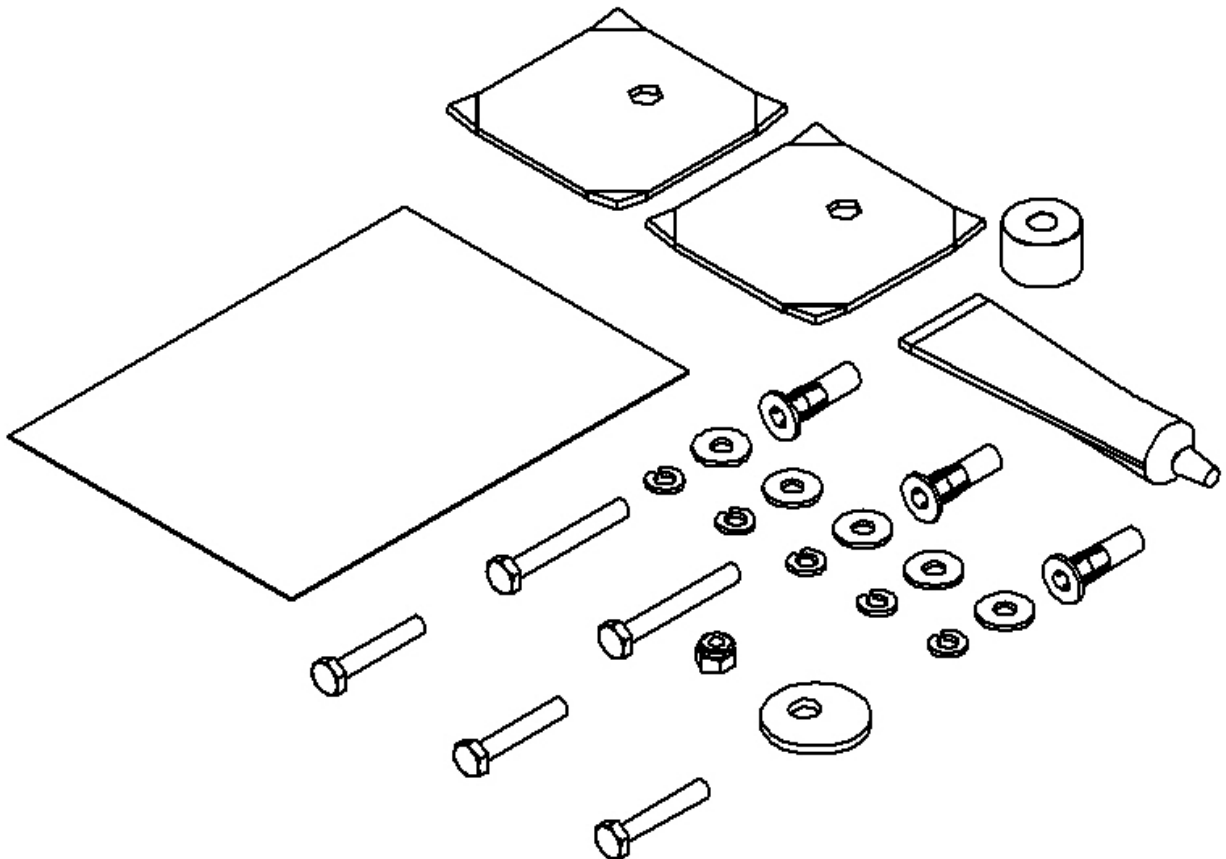

Installation and/or Assembly Fasteners
BAG33247-0

ITEM NO.	PART NUMBER	DESCRIPTION	QTY.
1	FAS0061	Screw, Truss Hd. Ph, 1/4-20x0.50	54
2	FAS0055	Nut, Hex Flange, Nylock 1/4-20	54
3	BAG0509-A	5" x 9" 4MIL AUTOBAG	1

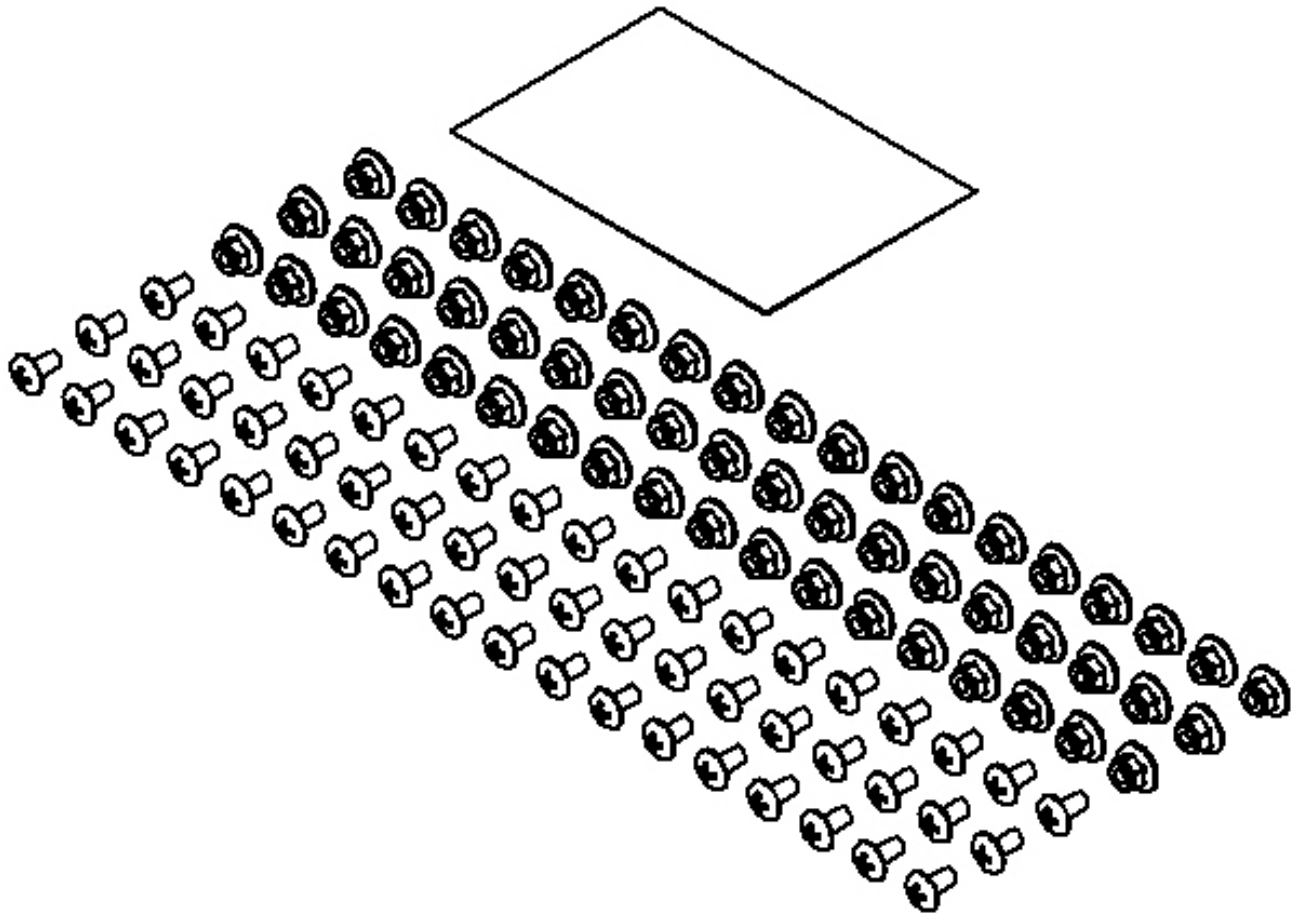

**Step 01 ASSEMBLE AND INSTALL SHELVING USING THE IMAGE BELOW
USE FAS0055 AND FAS0061 TO ASSEMBLE SHELVE**

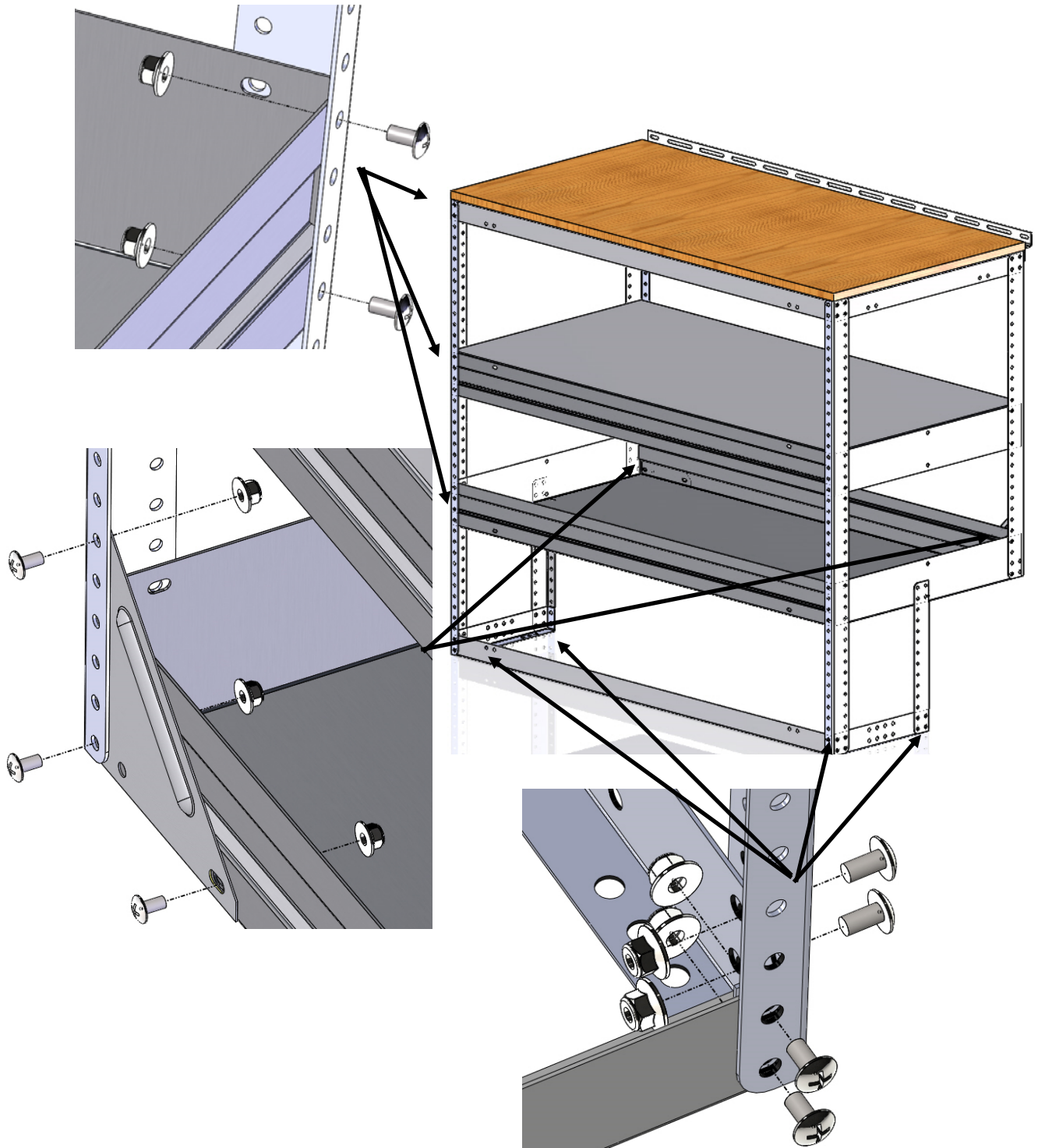

STEP 02 USE Z-RAIL INSTRUCTIONS TO INSTALL SHELF INTO VEHICLE