

Introduction / Comments:

Note:

It is advised that all fasteners used in this assembly and installation should be checked for tightness at the following intervals: @ 2-weeks and again @ 6-weeks of operation. This preventive maintenance step must be completed to ensure your Product gives you long service life.

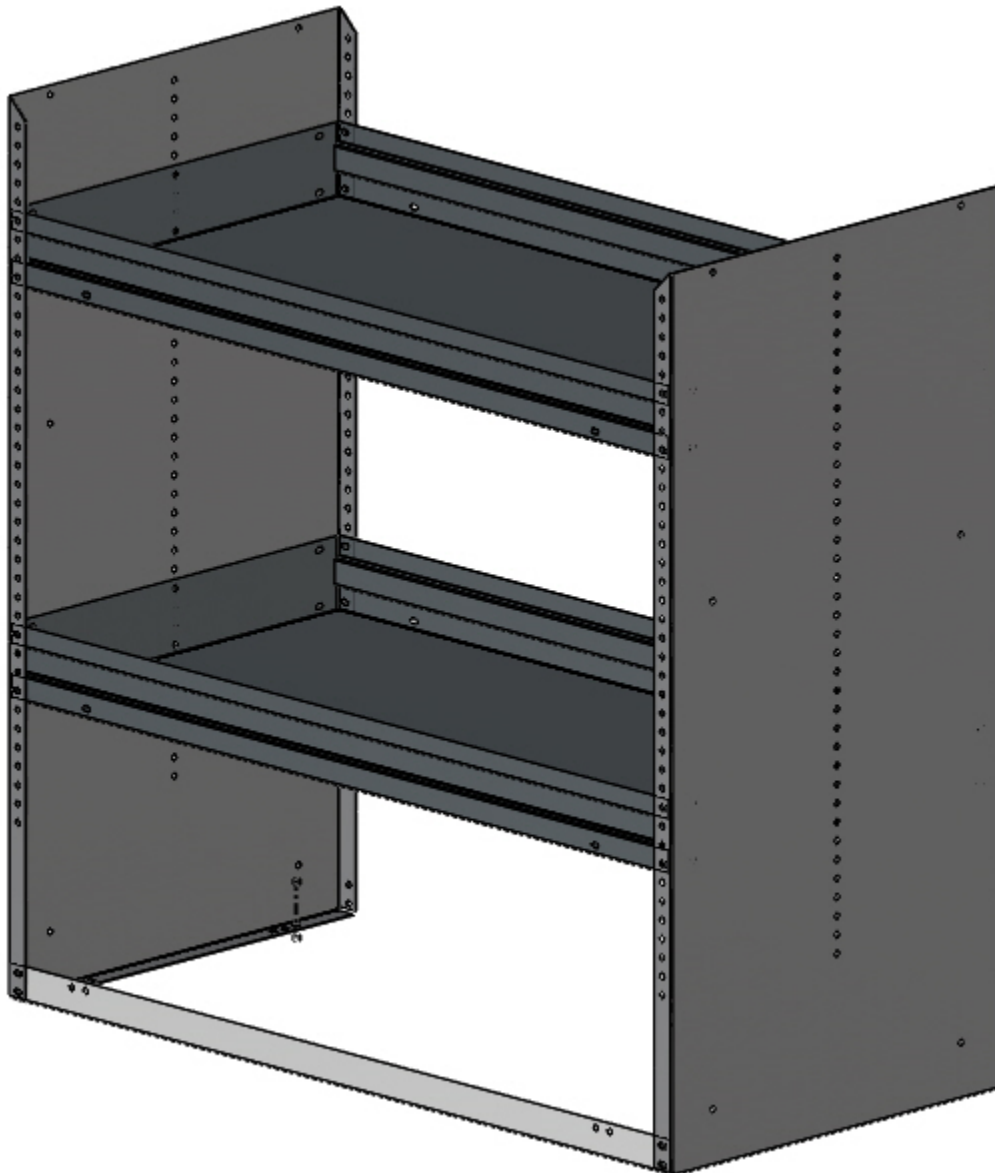

JD48FP
JD60FP

- PRECAUTIONS -



CAUTION
THE USE OF AIR IMPACT TOOLS CAN OVER-TORQUE FASTENERS AND CAUSE FASTENER FAILURE!



CAUTION
ALL INSTALLATION HOLES SHOULD BE SEALED WITH SILICON OR BUTYL SEALANT TO PREVENT EXHAUST FUMES FROM ENTERING THE VEHICLE!



DANGER
INSPECT FOR FUEL TANK, FUEL LINES, BRAKE LINES, HIGH VOLTAGE BATTERIES AND ELECTRICAL LINES PRIOR TO DRILLING TO AVOID DAMAGING CRITICAL VEHICLE SYSTEMS OR INJURY TO INSTALLER DURING INSTALLATION PROCESS!



CAUTION
TO AVOID DAMAGING THE VEHICLE ALWAYS USE DRILL STOPS WHEN DRILLING ANY INSTALLATION HOLES!
ADRIAN AVAILABLE PART #'S 31121-0 (3/8" X 1/2" DEEP), 31121-0 (1/2" x 1/2" DEEP)



- IMPORTANT WARRANTY REQUIREMENTS -

1. SUBSTITUTING ADRIAN STEEL SPECIFIED FASTENERS FOR ASSEMBLY AND/OR INSTALLATION WILL VOID YOUR PRODUCT WARRANTY.
2. ALL HOLES DRILLED INTO VEHICLE SHOULD HAVE THE RAW METAL EDGES SEALED WITH A SELF-ETCHING PRIMER TO RESIST CORROSION AND POTENTIAL FASTENER POINT FAILURE.
3. ALL FASTENERS USED IN THE INSTALLATION OF THIS PRODUCT SHOULD BE TIGHTENED TO THE TORQUE(S) SPECIFIED IN THESE INSTRUCTIONS.
4. THESE INSTRUCTIONS SHOULD BE KEPT WITH THE VEHICLE.

THE BASIC TOOLS NEEDED FOR MOST INSTALLATIONS



DRILL



DRILL BIT WITH STOP



RATCHET, SOCKETS AND/OR WRENCHES



SCREWDRIVERS



MEASURING TAPE

ADDITIONAL TOOLS MAY BE NEEDED FOR THIS INSTALLATION AND THEY WILL BE IDENTIFIED IN THE STEPS THAT FOLLOW.

If your vehicle contains carpet or a rubber floor mat you will need to prepare the mounting location. Position the product to be installed into the vehicle and once you are satisfied with the mounting locations, mark the mounting locations. Using a 1-3/16" diameter carpet cutter (P/N: 31183-0). Select the appropriate floor spacers as shown in the illustration. Set those aside for use later into the installation process. Using the correct drill bit size for the selected plusnut, drill the mounting holes in the vehicle sheet metal to prepare for installing the plusnuts. If you are thru-bolting at any of the locations simply drill a hole that is 1/16" larger than the bolt size(s) for those locations. Once you have drilled the holes into the vehicle, the raw metal edges should be sealed using a self-etching primer to resist corrosion and potential fastener point failure.

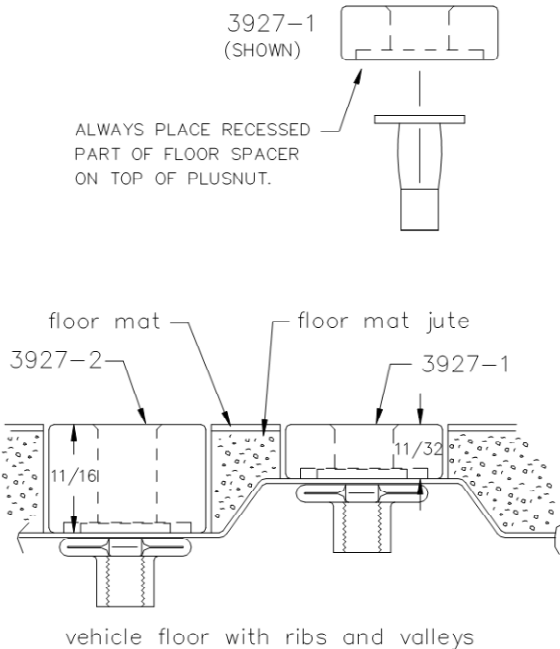

A PLUSNUT (RIVNUT) SETTING TOOL IS REQUIRED FOR PLUSNUT (RIVNUT) INSTALLATION . PLUS NUT SETTING TOOL CAN BE ORDERED THROUGH ADRIAN STEEL, OR USE AN AIR POWERED PLUSNUT SETTING GUN.

1/4-20UNC Plusnut (FAS0052) Use 3/8" dia. drill w/stop
 FAS0080 SCREW, HXHD, 1/4-20UNCx2.00", G8
 FAS0067 WASHER, FLAT, 1/4"ID
 22200-0 PLUSNUT TOOL

5/16-18UNC Plusnut (FAS0091) Use 1/2" dia. drill w/stop
 FAS0095 SCREW, HXHD, 5/16-18UNCx2.00", G8
 FAS0086 WASHER, FLAT, 5/16"ID
 22200-0 PLUSNUT TOOL

Place barrel of the plusnut body in sheet metal thru hole until flange is flush with sheet metal.
 Using a 9/16" combination wrench of plusnut tool body and a second hand wrench, ratchet, or air tool, rotate the hex bolt head CW to draw plus nut flanges up (set the plusnut).

**Installation and/or Assembly Fasteners
BAGINSTL-C**

| ITEM NO. | PART NUMBER | DESCRIPTION | QTY. |
|----------|-------------|--|------|
| 1 | BAG0507-A | 5" x 7" 3MIL AUTOBAG | 1 |
| 2 | FAS0055 | Nut, Hex Flange, Nylock 1/4-20 | 2 |
| 3 | FAS0063 | Screw, Hex Hd, 1/4-20x0.75 Zn Plate, Grade 5 | 2 |
| 4 | FAS0086 | WASHER, FLAT USS 5/16 ZP | 4 |
| 5 | FAS0091 | Plusnut, 5/16 | 4 |
| 6 | FAS0092 | Screw, Hex Hd, 5/16-18x1 .50 Zn Plate, G8 | 4 |
| 7 | FAS0098 | Washer, Lock, Split, 5/16, Zinc Plate | 4 |
| 8 | 03927-2 | Tall Floor Spacer | 4 |

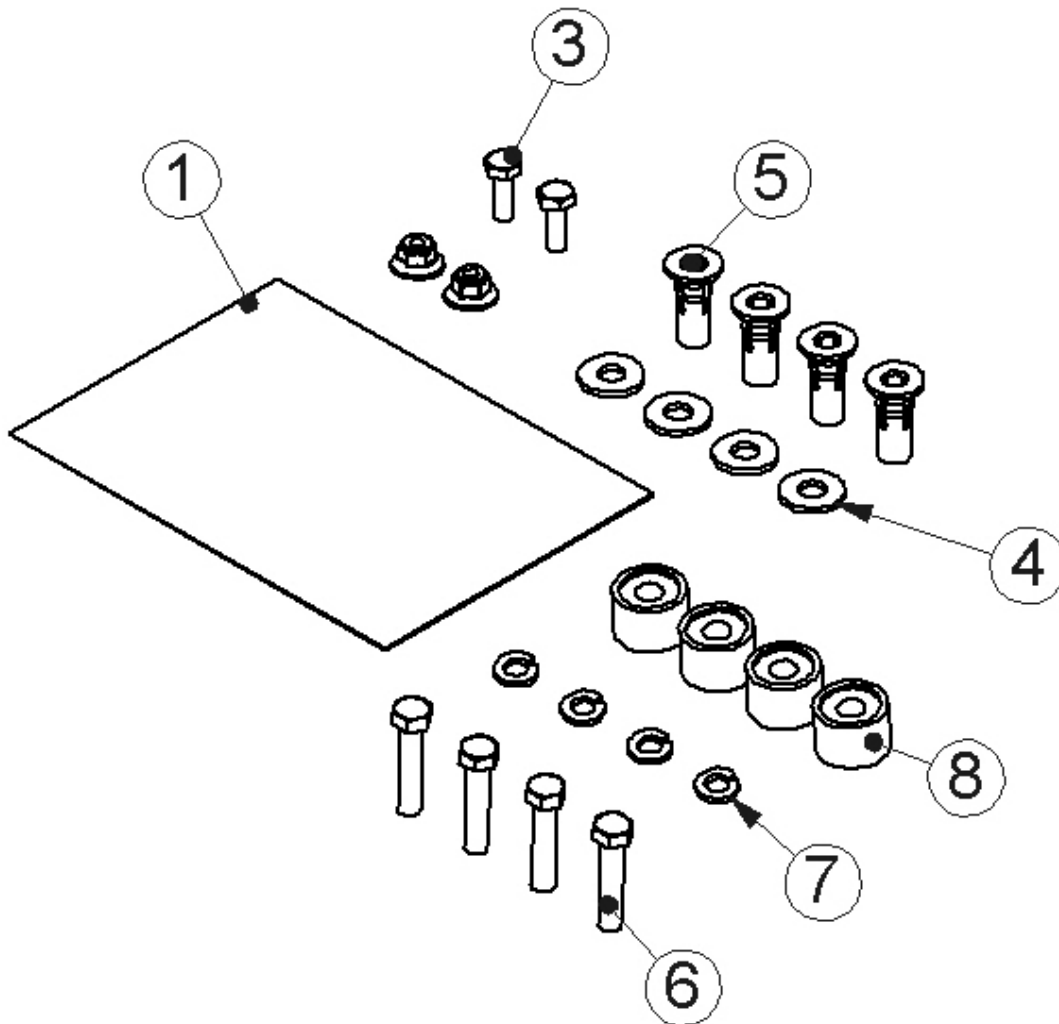

**Installation and/or Assembly Fasteners
BAG00016-0**

| ITEM NO. | PART NUMBER | DESCRIPTION | BAG00016-0/QTY. |
|----------|-------------|---|-----------------|
| 1 | BAG0507-A | 5" x 7" 3MIL AUTOBAG | 1 |
| 2 | FAS0055 | Nut, Hex Flange, Nylock 1/4-20 | 28 |
| 3 | FAS0061 | Screw, Truss Hd. Ph, 1/4-20x0.50 | 28 |
| 4 | FAS0041 | Screw, Truss Hd Phillips Tapping, #14-10x0.75 (A) | 16 |
| 5 | FAS 0066 | Washer, Lock, Ext. Tooth, 1/4 | 16 |

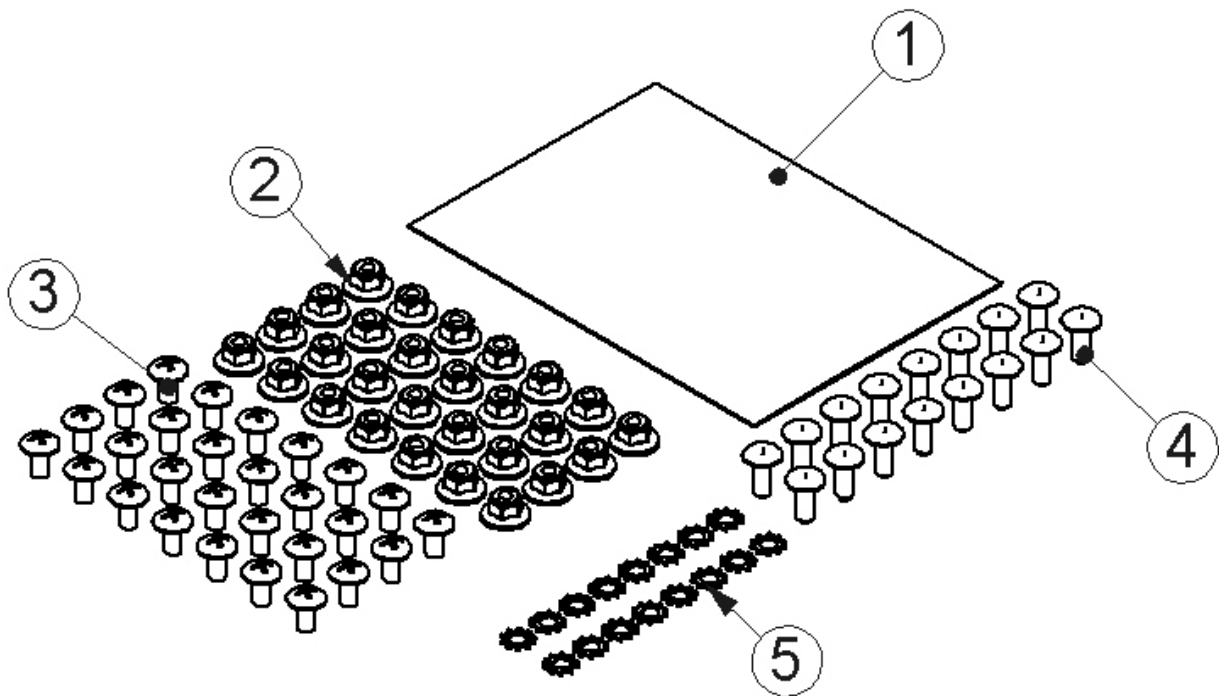

Step 01 ASSEMBLE SHELVING USING THE IMAGE BELOW

