

FASTENER GROUPS LISTED BELOW ARE USED FOR ASSEMBLY AND INSTALLATION. **SOME ASSEMBLY DRILLING IS REQUIRED.** PARTITION INSTRUCTIONS & FASTENERS ARE WITH THAT UNIT. USE KD UNIT DRAWINGS TO IDENTIFY THEIR SEPARATE PARTS. CUSTOMER SPECIFIED SHELF DIMENSIONS ARE SHOWN HERE.

SYM.	FASTENERS	QTY	DRILL
●	ASSEMBLY FASTENERS		
	{ 1/4-20 x 1/2" THP.SCW.	{ (16)	{ 9/32
	{ 1/4-20 HX. FLANGE NUT	{ (16)	
●	{ 10-24 x 1/2 RHP.SCW.	{ (8)	{ 3/16
	{ 10-24 HX. FLANGE NUT	{ (8)	
⊕	{ 10-24 X 1/2 RHP.SCW.	{ (4)	{ 3/16
	{ 10-24 ELASTIC L'NUT	{ (4)	

ADRIAN STEEL CO.
 906 JAMES STREET
 ADRIAN, MI 49221
 517/265-6194

DOOR KIT
 for #50/30-52
 WITH BACK

DWG BY: BOS 6071
 DATE: 6/6/02
 CHK BY: [Signature]
 PACKAGE WEIGHT: 17.94 #
 REF: 16594
 HCG= 00 VCG= 00

ITEM	PART NO.	DESCRIPTION	QTY.
1	16362	DOOR ASM. 52" (49-5/8)	1
2	16366	DOOR STOP 51"	1
3	BP1252	BACK PANEL, 12 x 52	1
4	21000	LOCKING T HNDL W/KEY ASCO	1

BAG00032-0 FAS FOR MISC DR KITS 1
 CRT00003-0 CARTON 1

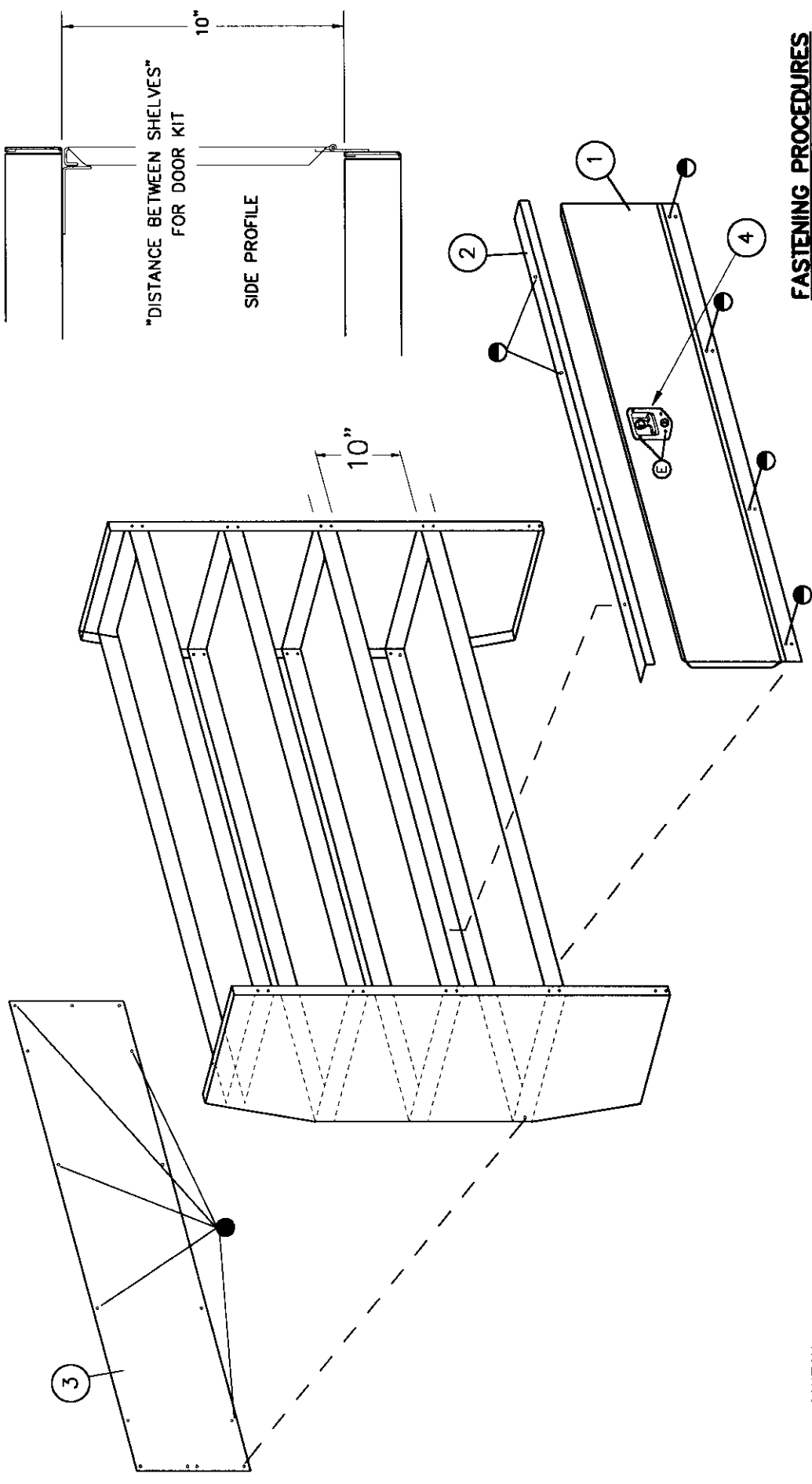

FASTENING PROCEDURES

1. USE NUT & BOLT THRU WHEREVER POSSIBLE.
2. USE PLUSNUTS FOR BLIND FASTENING.
3. USE SHEET METAL SCREWS IN SHEAR ONLY.

CAUTION:
 DRILL THRU FLOOR WITH CARE
 WATCH FOR GAS TANK, CONTROL
 LINES, & ELECTRICAL WIRING.