

PRINTED DOCUMENT IS UNCONTROLLED

REVISION LEVEL: **H**
 Part Number: **AD100**
 ECN-26780
 Date:
for reference only!

THIS PRODUCT IS SUBJECT TO CHANGE.
 ADRIAN STEEL COMPANY RESERVES THE RIGHT TO
 CHANGE THE PRODUCT OF IT'S DESIGN WITHOUT
 PRIOR NOTICE.

THIS DRAWING IS THE PROPERTY OF ADRIAN STEEL COMPANY
 AND IS NOT TO BE USED IN ANY MANNER DETRIMENTAL TO
 THE INTERESTS OF ADRIAN STEEL COMPANY.

Shipping Wt. (Lbs.):

Coating/Finish: **NATURAL**

Do Not Scale This Drawing!

906 James St.
 Adrian, MI 49221
 517.265.6194

Part Description: **CROSSBOX, SGL 12" FLEETSIDE, FSPU**

Part Number: **AD100**

REVISION LEVEL: **H**



Single/Double Lid Cross Box / Sidebox Installation Instructions

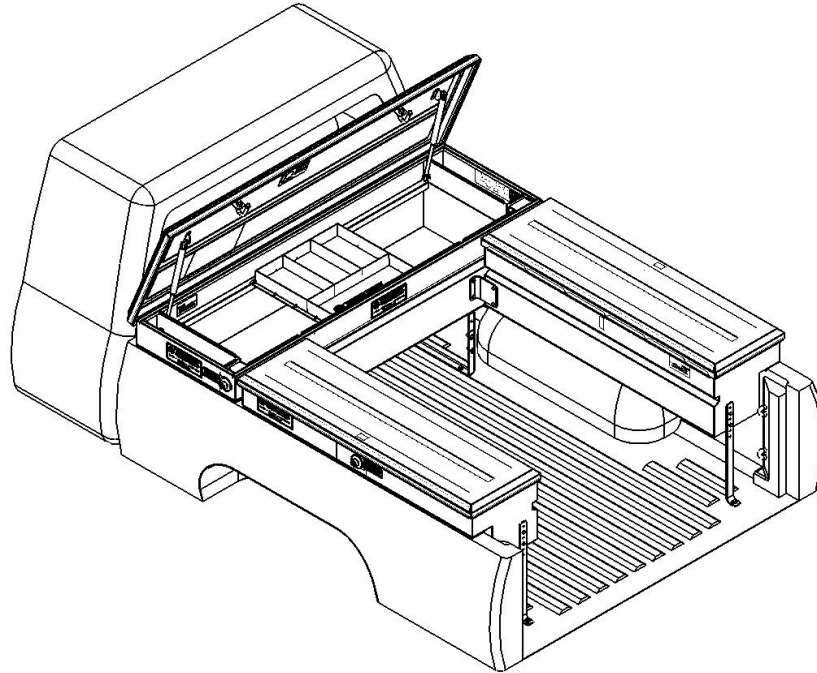

ECN- 26780 DATE: 03/14/2024 DWG.BY: JLC REV.BY: TS CHK.BY: _____ ISSUE: F P.N.: 26649-0

**ALUMINUM SINGLE LID
CROSS BOXES**

- AD100
- AD101
- AD101-2
- AD120
- AD150
- AD151
- AD160
- AD190

**ALUMINUM DOUBLE LID
CROSS BOXES**

- AD200
- AD201
- AD201-2
- AD220
- AD250
- AD260
- AD290

**ALUMINUM
SIDE BOXES**

- AD302
- AD303
- AD350

NOTE:
AD160 / AD260 CROSS BOXES HAVE
ADDITIONAL SUPPORT BRACKETS



Aluminum Toolboxes

BEFORE YOU START!

THIS PRODUCT IS MEANT TO STORE AND TRANSPORT, HAND TOOLS, SMALL EQUIPMENT OR INERT MATERIALS. ANY MISUSE OR INTENTIONAL MODIFICATION SHALL VOID ANY RESPONSIBILITIES TO THE MANUFACTURE. THIS BOX IS NOT INTENDED TO TRANSPORT ANY EXPLOSIVE OR HAZARDOUS MATERIAL.



IMPORTANT INSTALLATION STEPS ARE DENOTED USING A STOP SIGN. THESE STEPS MUST BE PERFORMED AS SPECIFIED IN ORDER TO ENSURE A PROPER INSTALLATION AND MUST BE FOLLOWED IN ORDER TO MAINTAIN YOUR PRODUCT WARRANTY!



CRITICAL INFORMATION PERTAINING TO USER AND/OR VEHICLE SAFETY IS DENOTED USING A CAUTION SIGN. SAFETY ITEMS MUST BE STRICTLY ADHERED TO IN ORDER TO ENSURE A SAFE WORKING ENVIROMENT!



YOU WILL NEED THE FOLLOWING TOOLS IN ORDER TO COMPLETE THIS JOB.

3/8" ELECTRIC DRILL MOTOR, 9/32" & 13/32" DRILL BITS, 1" diameter HOLE SAW
COMBINATION END WRENCHES, 7/16" & 1/2"
RATCHET WRENCH , 7/16" & 1/2" SOCKETS
TAPE MEASURE, PENCILS, HAMMER, BOX CUTTER, CENTER PUNCH, DEBURR TOOL
PHILLIPS SCREWDRIVER (#3 POINT)

ALL FASTENERS USED IN THE ASSEMBLY AND INSTALLATION OF THIS PRODUCT SHOULD BE TIGHTENED TO THE SPECIFIED TORQUE AS LISTED WITH EACH FASTENER CALLOUT BOX.



THE USE OF AIR OR ELECTRIC IMPACT TOOLS FOR THE ASSEMBLY OF FASTENERS IS NOT RECOMMENDED AND COULD CAUSE FASTENER FAILURE!



WARNING



THE USE OF DRILLS WITH INTEGRAL DRILL STOPS ALONG WITH PROPER INSPECTION FOR GAS TANK, GAS LINES, BRAKE LINES AND ELECTRICAL LINES PRIOR TO DRILLING ANY MOUNTING HOLES IS STRONGLY RECOMMENDED TO ENSURE THAT VEHICLE DAMAGE IS AVOIDED!







Aluminum Toolboxes

THE USE OF NON-STANDARD FASTENERS AND/OR DEVIATING FROM THE FASTENERS SPECIFIED IN THE INSTRUCTION(S) MAY VOID YOUR PRODUCT WARRANTY!

ALL DRILLED HOLES IN THE VEHICLE SHOULD HAVE THE RAW METAL EDGES SEALED WITH A SELF-ETCHING PRIMER TO RESIST CORROSION AND POTENTIAL FASTENER POINT FAILURE!

Whenever a plusnut is specified it is important that the proper size installation hole is provided.

PLUSNUT SIZE		DRILL SIZE <i>(with stop)</i>
1/4-20 PLUSNUT, FAS0218		3/8" DIAMETER
5/16-18 PLUSNUT, FAS0091		1/2" DIAMETER
22200-0 PLUSNUT TOOL		NOTE: PLUSNUT TOOL NOT SUPPLIED WITH THIS KIT. ORDER PLUSNUT TOOLS FROM ADRIAN STEEL OR USE INSTALLATION TOOLKIT 31291-0

Using specified drill bit with drill stop, drill holes at the marks you made in the pickup bed chassis.

Clean up debris from drilling and Install a 1/4-20UNC plus nut into each hole and set the plusnut as shown in illustration.

ASSEMBLE THE FOLLOWING

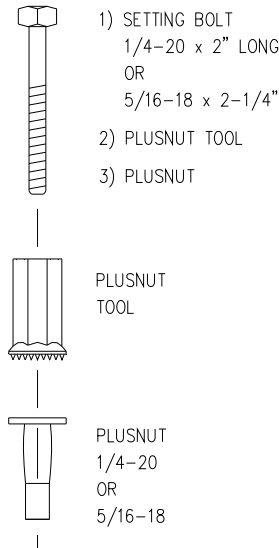

SETTING THE PLUSNUT

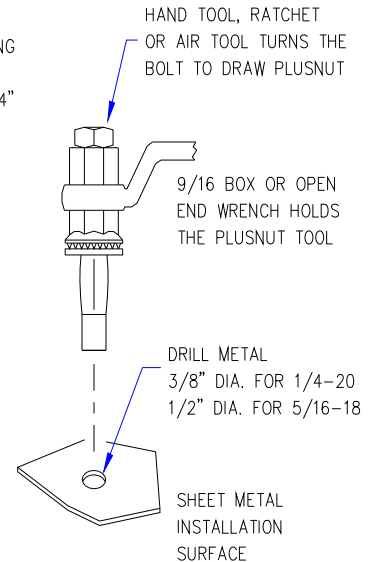



Aluminum Toolboxes

STEP – 01

CROSSBOX FOAM TAPE APPLICATION

If you are installing SIDE BOXES ONLY (NO CROSSBOX) proceed directly to STEP 06 at this time.

Cut supplied foam tape into (2) 20 inch long sections and apply to the cross box (street and curb side). Position foam tape in the approximate center of the tool box flange as shown in detail views below. After foam tape has been applied, using box cutters slit the tape in the crossbox slots to allow inserting of NO-DRILL BRACKET fasteners in the next step.

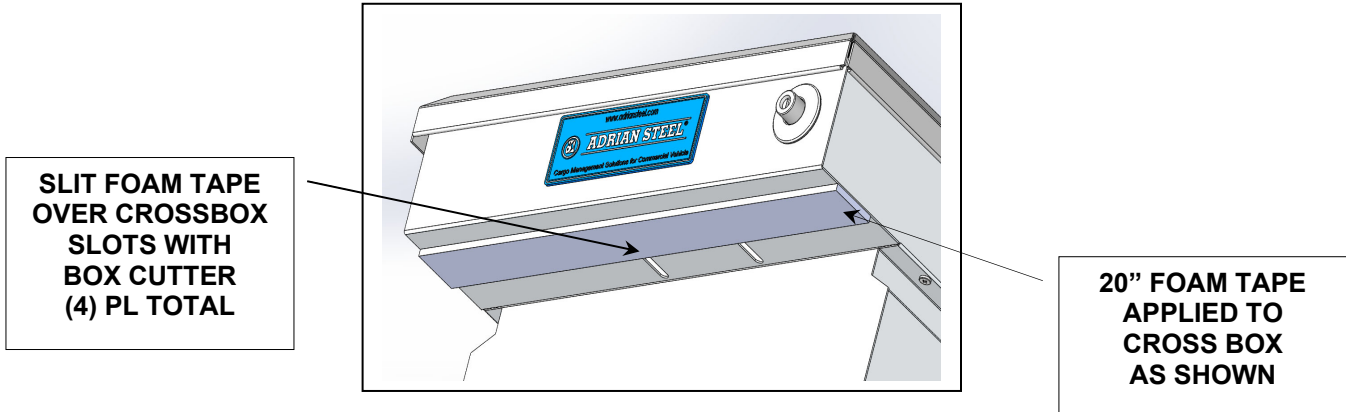

For 5.5' beds, stack (2) 43305 in each corner on each side to lift the toolbox.







STACK (2) 43305 BETWEEN TOP BED RAIL AND BOTTOM OF FOAM TAPE ON TOOLBOX. DO THIS AT ALL FOUR CORNERS OF TOOLBOX (8ea 43305 TOTAL). THIS KEEPS THE TOOLBOX FROM RESTING ON THE WHEEL WELL.



Aluminum Toolboxes

STEP – 02

CROSSBOX & NO-DRILL BRACKET INSTALLATION

 <p>FAS0433 SCREW, HEX HD, 5/16-18UNC X 3.5" (4) REQ'D</p>	 <p>FAS0098 WASHER, SPLIT LOCK, 5/16" ID (4) REQ'D</p>	 <p>21660-0 WASHER, ECCENTRIC, 3/8" ID (4) REQ'D</p>	 <p>26648-0 NO-DRILL BRACKET W/RIVNUT (2) REQ'D</p>
--	--	--	---

Open the lid and attach the NO-DRILL BRACKETS (ref: 26648-0) to the CROSS BOX as shown below. Thread the 5/16-18UNC x 3.5" hex head screws into the no-drill bracket rivnuts approximately 1/2" and allow brackets to hang freely. Repeat for the opposite side.

Position the NO-DRILL BRACKET and fasteners in toward the center of the toolbox as far as slots will allow.

Place toolbox in truck bed and center toolbox between bed rails. Fully open toolbox lid to check clearance between toolbox lid and cab, or any installed truck bed accessories. Adjust toolbox placement if require. A notch must be cut in "over the rail" and some "under the rail" bedliners to allow the NO-DRILL BRACKETS to be installed correctly.

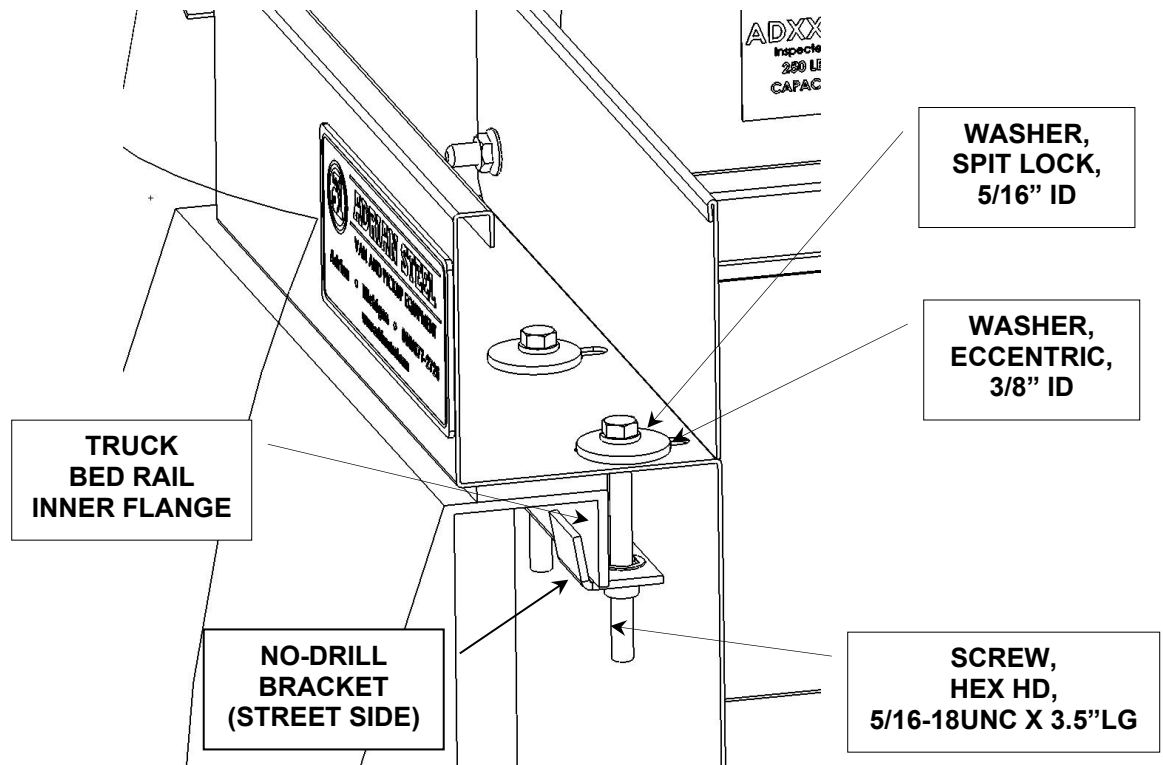



STEP – 03

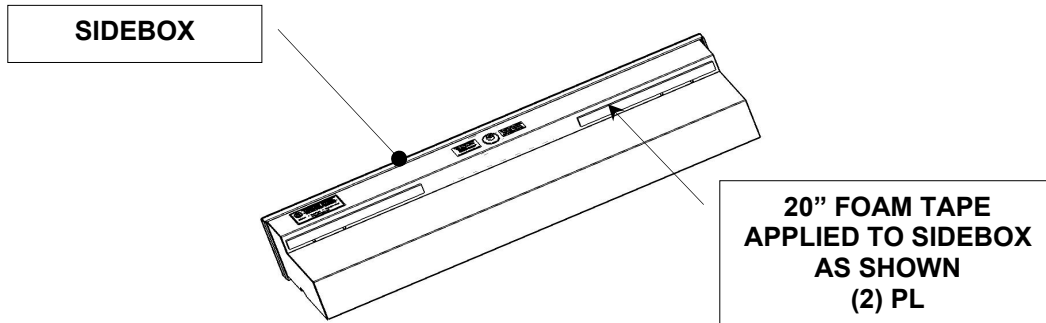

SIDEBOX FOAM TAPE INSTALLATION

Cut supplied foam tape into (2) 20 inch long sections. Apply tape to the side box (street and curb side). Position foam tape approximately centered on side box flange as shown in detail views below. After foam tape has been applied, slit the tape in all four slots to allow inserting of no-drill bracket fasteners.



STEP – 04



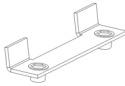





SIDEBOX & NO-DRILL BRACKET INSTALLATION

 <p>FAS0433 SCREW, HEX HD, 5/16-18UNC X 3.5" (8) REQ'D</p>	 <p>FAS0098 WASHER, SPLIT LOCK, 5/16" ID (8) REQ'D</p>	 <p>21660-0 WASHER, ECCENTRIC, 3/8" ID (8) REQ'D</p>	 <p>26648-0 NO-DRILL BRACKET W/RIVNUT (4) REQ'D</p>
--	--	--	---

Open the side box lid and attach the NO-DRILL BRACKETS (ref: 26648-0) as previously outlined in step 02 of the crossbox installation.

Set the SIDEBOX onto the truck bed rails as shown below. Allow NO-DRILL BRACKET to hang freely between bed rails and sidebox. Slide sidebox forward until the sidebox and crossbox are in line (or as close as possible) on truck bed rails. A notch must be cut in "over the rail" and some "under the rail" bedliners to allow the NO_DRILL BRACKETS to be installed correctly. Leave enough clearance between the sidebox and crossbox so that lids will open freely without contacting each other.

**STEP – 05****SIDEBOX / CROSSBOX SUPPORT BRACKET INSTALLATION**

 FAS0063 SCREW, HEX HD, $\frac{1}{4}$ -20UNC X $\frac{3}{4}$ " (4) REQ'D	 FAS0060 WASHER, SPLIT LOCK, $\frac{1}{4}$ " ID (2) REQ'D	 FAS0067 WASHER, FLAT, $\frac{1}{4}$ " ID (2) REQ'D	 28402-0 SIDE BOX LEG BRACKET (2) REQ'D
 FAS0078 SCREW, HEX HD, $\frac{1}{4}$ -20UNC X 1" (2) REQ'D	 FAS0218 $\frac{1}{4}$ -20UNC PLUSNUT (2) REQ'D	 FAS0055 NUT, HEX FLANGE, $\frac{1}{4}$ -20UNC (4) REQ'D	 28403-0 SIDE BOX TIE BRACKET (1) REQ'D

Position the SIDEBOX LEG BRACKETS vertically as shown below, to allow for clearance of the wheelhouse. Mark (2) of the (6) through holes in the bracket on the end wall of the side box. Next mark the through hole for the truck bed floor plusnut location.

Center punch all marked holes. Drill a $\frac{9}{32}$ " diameter through hole (2) places on each side box end panel and deburr holes as required. Inspect for gas tank, gas line, and/or any electrical line locations prior to drilling. Drill a $\frac{13}{32}$ " diameter hole in the truck bed floor. Use drill with drill stops set for $\frac{1}{2}$ " drill depth.

Set the $\frac{1}{4}$ -20UNC plusnuts into the $\frac{13}{32}$ " diameter holes you just drilled into the truck bed floor. Follow the plusnut setting instructions at the beginning of this installation instruction. After all the plusnuts have been set, position and secure the leg brackets to the side box end panels using the fasteners listed. Secure the leg brackets to the truck bed floor with the fasteners listed.

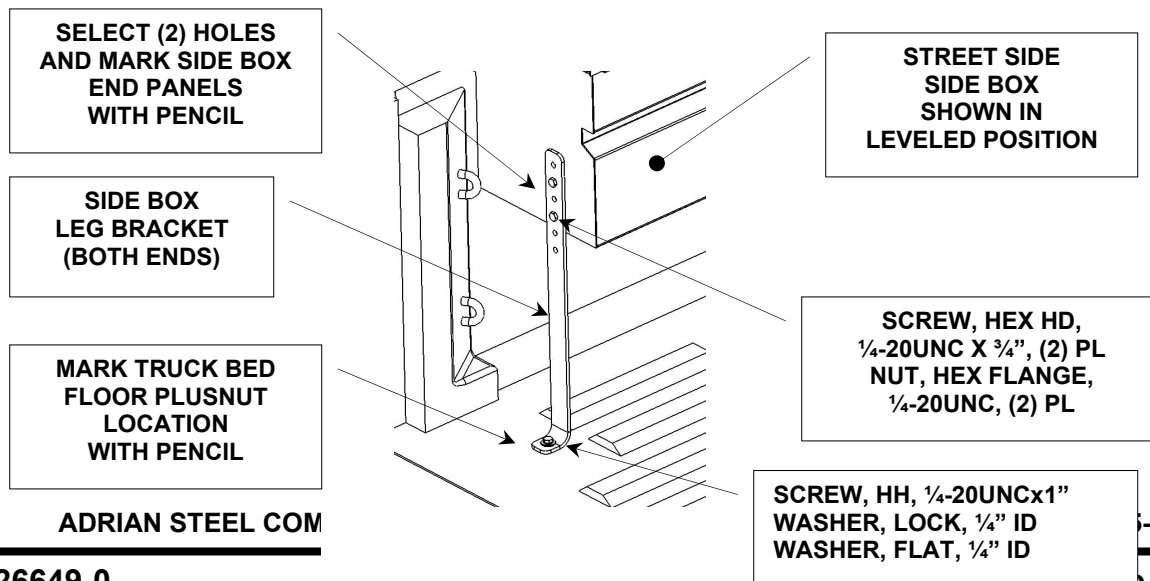
STEP – 05**(continued)**



Aluminum Toolboxes

Position the SIDEBOX TIE BRACKET as shown, mark all (4) through holes on the crossbox and side box panels. Center punch all (4) holes and drill a 9/32" diameter hole, deburr holes as required.

Align the through holes in the TIE BRACKET with the drill holes in the crossbox and sidebox. Secure the TIE BRACKET in place using fasteners shown below.

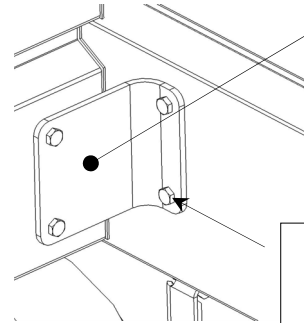
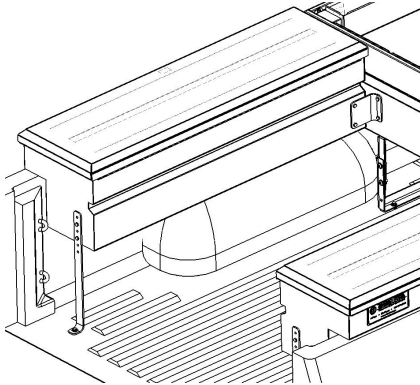

SIDEBOX TIE
BRACKET

SCREW, HEX HD,
1/4-20UNC X 3/4", (2) PL
NUT, HEX FLANGE,
1/4-20UNC, (2) PL

STOP

**DOUBLE-CHECK ALL FASTENER LOCATIONS TO BE
SURE THAT ALL FASTENERS ARE TIGHTENED TO
SPECIFICATIONS!**

STOP

**YOUR INSTALLATION OF YOUR CROSSBOX AND SIDBOXES IS NOW COMPLETE!
STOW THIS COPY IN THE VEHICLE FOR FUTURE REFERANCE!**



Aluminum Toolboxes

THE SECTION OUTLINES INSTALLATION OF (2) SIDEBOXES ONLY!







STEP – 06

SIDEBOX FOAM TAPE INSTALLATION & NO-DRILL BRACKET INSTALLATION PLEASE REFERE TO STEPS 3 & 4 ABOVE.

Cut supplied foam tape into (2) 20 inch long sections and apply to the side box. Position foam tape approximately centered on side box flange as shown in detail views below. After foam tape has been applied, slit the tape in the side box fastener slots to allow inserting of no-drill bracket fasteners.

STEP – 07

SIDE BOX SUPPORT BRACKETS INSTALLATION

 FAS0063 SCREW, HEX HD, 1/4-20UNC X 3/4" (8) REQ'D	 FAS0060 WASHER, SPLIT LOCK, 1/4" ID (4) REQ'D	 FAS0067 WASHER, FLAT, 1/4" ID (4) REQ'D	 28402-0 SIDE BOX LEG BRACKET (4) REQ'D
 FAS0078 SCREW, HEX HD, 1/4-20UNC X 1" (4) REQ'D	 FAS0218 1/4-20UNC PLUSNUT (4) REQ'D	 FAS0055 NUT, HEX FLANGE, 1/4-20UNC (8) REQ'D	

Position the SIDEBOX LEG BRACKETS vertically as shown below, to allow for clearance of the wheelhouse. Select (2) holes and mark both front & rear as shown below. Next mark the through hole location for the truck bed floor plusnut location on both ends.

Center punch all marked holes Drill a 9/32' diameter through hole (2) places on each of the sidebox end panel marked hole locations, deburr holes as required. Inspect for gas tank, gas line, and/or any electrical line locations prior to drilling. Next drill a 13/32" diameter hole in the truck bed floor. Use drill with drill stops set for 1/2" drill depth. Set plusnuts into truck bed floor. After all the plusnuts have been set, position and secure the leg brackets to both of the sidebox end panels using the fasteners shown. Secure the leg brackets to the truck bed floor with the fasteners listed on next page.



Aluminum Toolboxes

Repeat procedure for the sidebox opposite side.

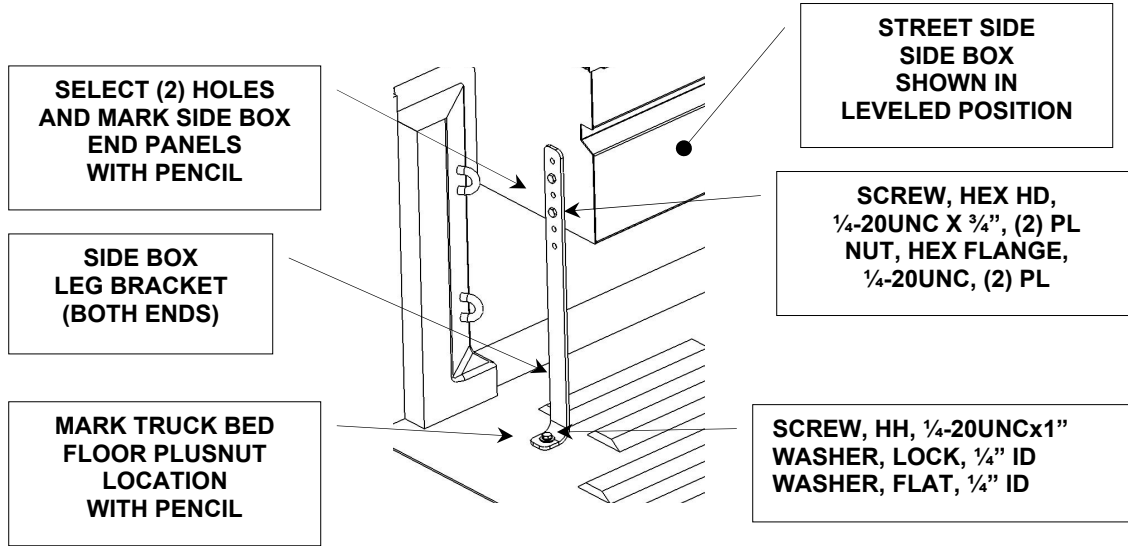

DOUBLE-CHECK ALL FASTENER LOCATIONS TO BE SURE THAT ALL FASTENERS ARE TIGHTENED TO SPECIFICATIONS!



YOUR INSTALLATION OF YOUR SIDEBOXES IS NOW COMPLETE! STOW THIS COPY IN THE VEHICLE FOR FUTURE REFERENCE!