

Introduction / Comments:
700W & 1kW Inverter Kit for Ford Maverick ICE

Please Note:

1. Read all instructions prior to installation. Review the Adrian Steel **GENERAL PRECAUTIONS PAGES (56638)** before attempting installation. Only personnel familiar with using electrical best practices should perform this install. Reference **ELECTRICAL BEST PRACTICES MANUAL (54479)** before attempting installation.
2. Review order drawings to determine inverter placement.
3. Also if any power strip kits will need to be installed also and their placement.
4. Not all applications will use all the components listed.
5. **These instructions cover Maverick ICE.**

For Ford Maverick ICE



700W



1000W





[69892]
700W & 1kW Inverter Kit for Ford Maverick ICE

Section 1: Table of Contents



<u>Table of Contents:</u>	
[700W & 1kW Inverter Kit for Ford Maverick ICE]	
Page 1: Cover Page/Introduction.....	1
Section 1: TOC & Safety Precautions information	2
Section 2: Cable Kit Part Identification	4
Section 3: Tools Needed & Fastener ID/Torque Table	5
Section 4: General Vehicle Layout	7
Section 5: General Wiring Diagram	8
Section 6: Vehicle Integration	
• Removing Trim in Preparation	10
• Routing Cables from Chassis Battery	14
• Chassis Battery Fuse Installation	16
• Remote Switch Harness Layout	20
• Switch Installation	22
Section 7: Inverter Mounting and Cabling	
• Wire and Cabling	23
• Mounting Inverter	29
• Wire and Cabling	30
Section 8: Settings & Important Labeling	33
Section 9: Test and Check.....	35
Section 10: Appendices	
A. FLEET Requested docs (Schematics, tools, Torque table)	37

Section 1: Table of Contents

These symbols are used in the document to warn installer to make sure there is understanding beyond general precautions used when working on electrical installations.

	ANSI Z535.6-2006 refers to the use of blue when “addresses practices not related to personal injury”.
	Yellow labelling level of personal injury = could result in minor injury.
	Red labelling level of personal injury = could / will result in death.

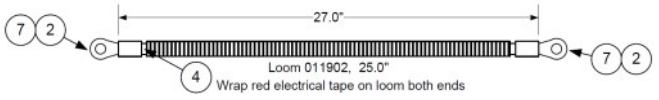
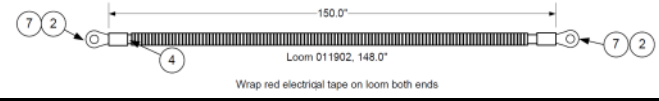
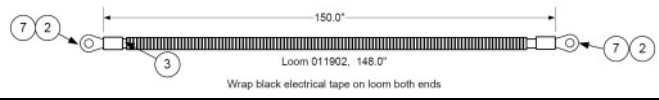
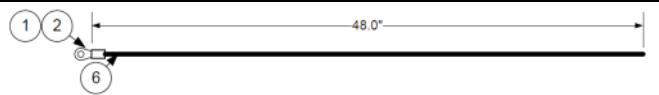
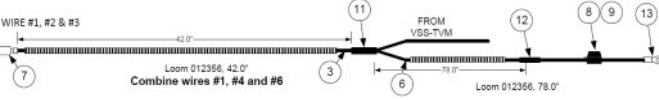
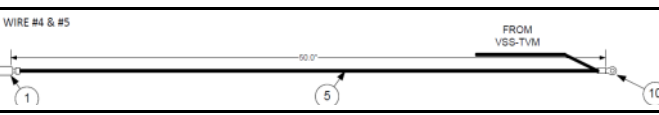
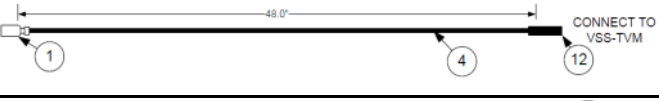
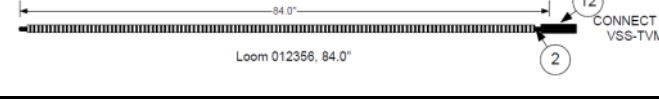
Section 2: Cable Kit Part Identification [KIT 69834 [ICE]: 700/1000W]:

Part Description & Label	Part Photo/Diagram
Kit PPDS Photo [Example: 69834 [ICE]: 700/1000W]: <ul style="list-style-type: none"> • Harness wires #1-#8, • Clamp, M8 Nut • Fuse holder, • Switch and Timer Harness Kit • Misc. Wire ties and fasteners 	
OEM Battery POSITIVE to FUSE cable “WIRE #1” - 27”, RED, Black Corrugate, POSITIVE	WIRE #1 
FUSE to INVERTER cable “WIRE #2” - 150”, RED, Black Corrugate, POSITIVE	WIRE #2 
OEM Battery Negative cable to INVERTER “WIRE #3” - 150”, BLACK, Black Corrugate, NEGATIVE	WIRE #3 
INVERTER GROUNDING WIRE to Chassis, “WIRE #4” - 48”, GREEN wire, GROUND	WIRE #4 
Battery WIRE to SWITCH and TIMER, “WIRE #5” - RED wire, Black Corrugate, HAAT	WIRE #5 
GROUND WIRE to SWITCH and TIMER, “WIRE # 6” - BLACK wire, GROUND	WIRE #6 
REMOTE SWITCH to TIMER “WIRE # 7” - WHITE wire, Black Corrugate, Remote Sig- nal	WIRE #7 
TIMER to INVERTER “WIRE # 8” - OR- ANGE wire, Black Corrugate, Remote Signal	WIRE #8 
Vanner Remote Switch and Timing circuit	

Section 3: Tools Needed & Fastener ID/Torque Table:



1. Insulated Splice Crimper
2. Wire Strippers
3. Diagonal Cutters
4. Plastic Trim Tool
5. Drill driver
6. Measuring tape
7. Phillips Bit with Bit holder
8. 3/4" Hole or Step Drill (Unibit)
9. Medium and Small (-) Screwdriver
10. Large #3 Phillips (+) Screwdriver
11. Sockets:
 - 8mm
 - 10mm
 - 5/16"
 - 3/8"
 - 7/16"
 - 1/2"
 - 13mm
 - Socket driver and extensions
12. Torque Wrench [~8-20Nm range]
13. Tin Snips
14. #3 Philips (+) & Medium slotted torque socket
15. Marker [Not Shown]

Figure 3-1: Tools Needed for Installation

Section 3: Tools Needed & Fastener ID/Torque Table:

Torque Table for KIT 69834 [ICE]: 700/1000W

ITEM NO.	ASC PN	Description	PCS	Torque Range	Use Wrench or Size
2	FAS0055	Nut, Hex Flange, Nylock 1/4-20	5	12Nm [+/- 1.8Nm] (106lb.in).	7/16"
3	FAS0018	SCREW,HH SFLNG 1/4-20X.62 ZP	4	12Nm [+/- 1.8Nm] (106lb.in).	7/16"
10	FAS0641	SCREW,HH TEK 1/4-20X.7 ZP	1	12Nm [+/- 1.8Nm] (106lb.in).	7/16"
4	6105169AA	NUT, M8,FUSE BOX,SPR	1	10Nm (89 lb.in)	13mm
11	FAS0148	Screw, Self Drill/Tap, Pan Ph. Hd.,	2	3Nm [+/- 0.5Nm] (27lb.in).	#2 Phillips
12	FAS0062	SCREW,THP 1/4-20X.75 G5 ZP	1	3Nm [+/- 0.5Nm] (27lb.in).	#2 Phillips

Ref. NO.	ASC PN/Function	Description	PCS	Torque Range	Use Wrench or Size
6	Inverter +/- Terminals	Phillips and slotted screws	Three (3) Positions	12.3Nm [+/- 0.7Nm] (9.5 lb.ft).	#3 Phillips and 1/4" Standard driver bits

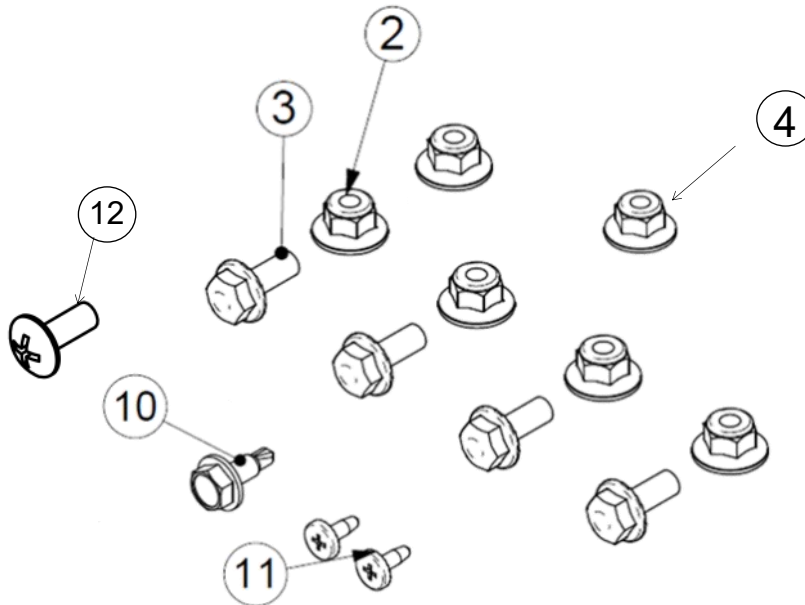

Other Fasteners in Vehicle

7	Battery positive post clamp fastener	10mm Nut	1	12Nm [+/- 1.2Nm] (106 lb.in).	10mm NUT
8	CB Negative Battery Cable to Chassis	13mm hex bolt	1	35Nm [+/- 1 Nm] (26 lb.ft).	13mm Nut

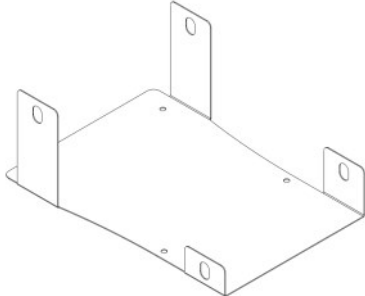
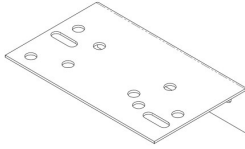

Section 3: Kit Fasteners and Torque Table

Torque Table KIT 67763 [ICE]: 700/1000W

Ref. NO.	ASC PN/Function	Description	PCS	Torque Range	Use Wrench or Size
16	67826 MAVERICK INVERTER BRACKET		1		
17	44918-B BRACKET, FUSE HOLDER, F150		1		
18	Cables to Bussman Fuse Holder		4	12Nm [+/- 1.8Nm] (106lb.in).	1/2"
19	Inverter +/- Terminals	Phillips and slotted screws	Three (3) Positions	12.3Nm [+/- 0.7Nm] (9.5 lb.ft).	#3 Phillips and 1/4" Standard driver bits
Other Fasteners in Vehicle					
20	CB Positive Battery Post Bus Bar	13mm Nut	2	12Nm [+/- 1.2Nm] (106 lb.in).	13mm NUT
21	CB Negative Battery Cable to Chassis	13mm hex bolt	1	35Nm [+/- 1 Nm] (26 lb.ft).	13mm Nut
22	AUX Battery positive and negative terminal fasteners	1/2" Nut	2	8Nm [+/- 1.2Nm] (71 lb.in).	1/2" Nut

Section 4: General Vehicle Layout [KIT 69834 [ICE]: 700/1000W]

- Use sales order drawing to place all equipment.

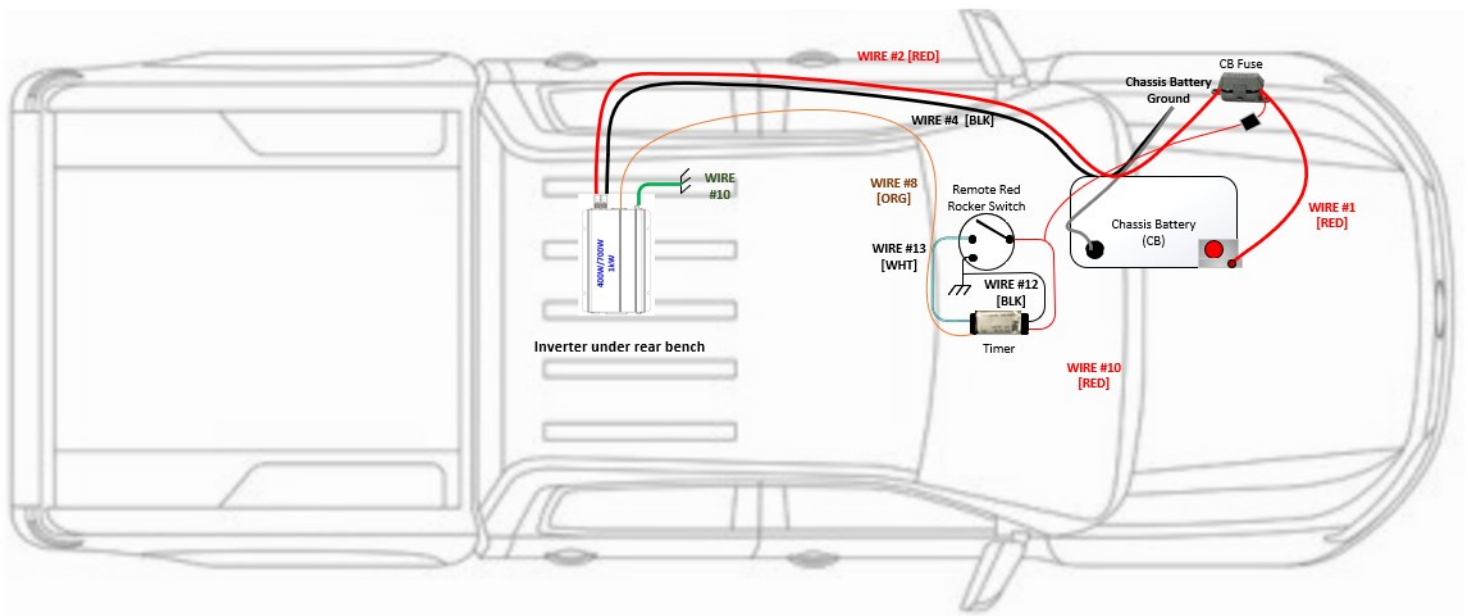

Figure 4-1: Top View Diagram

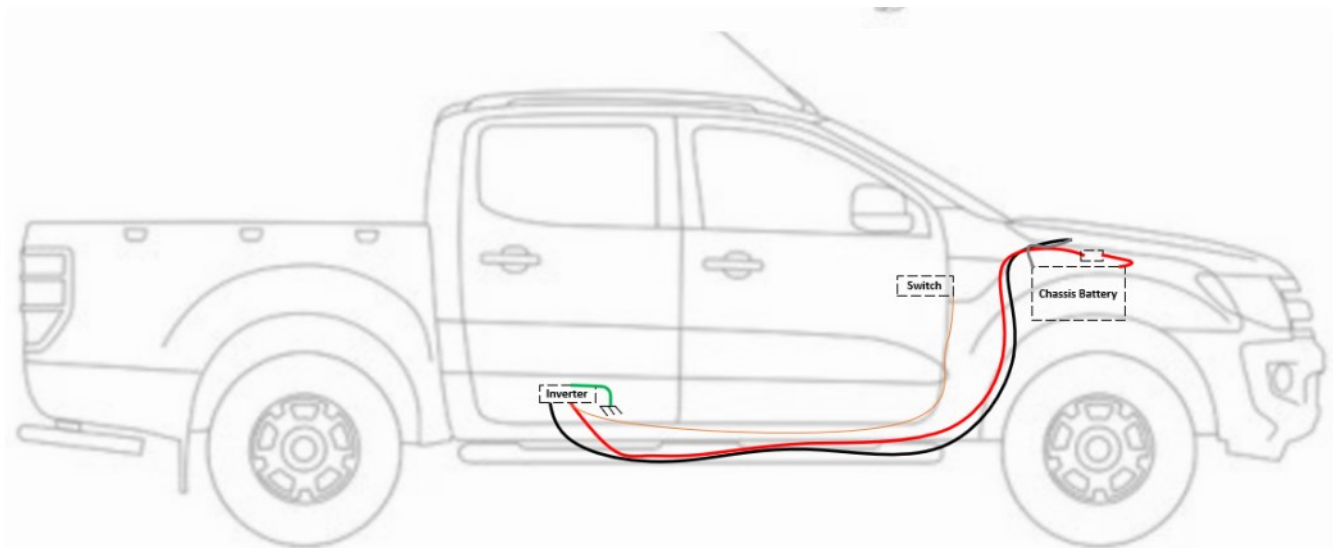

Figure 4-2: Side View Diagram

Section 5: General Wiring Diagram:

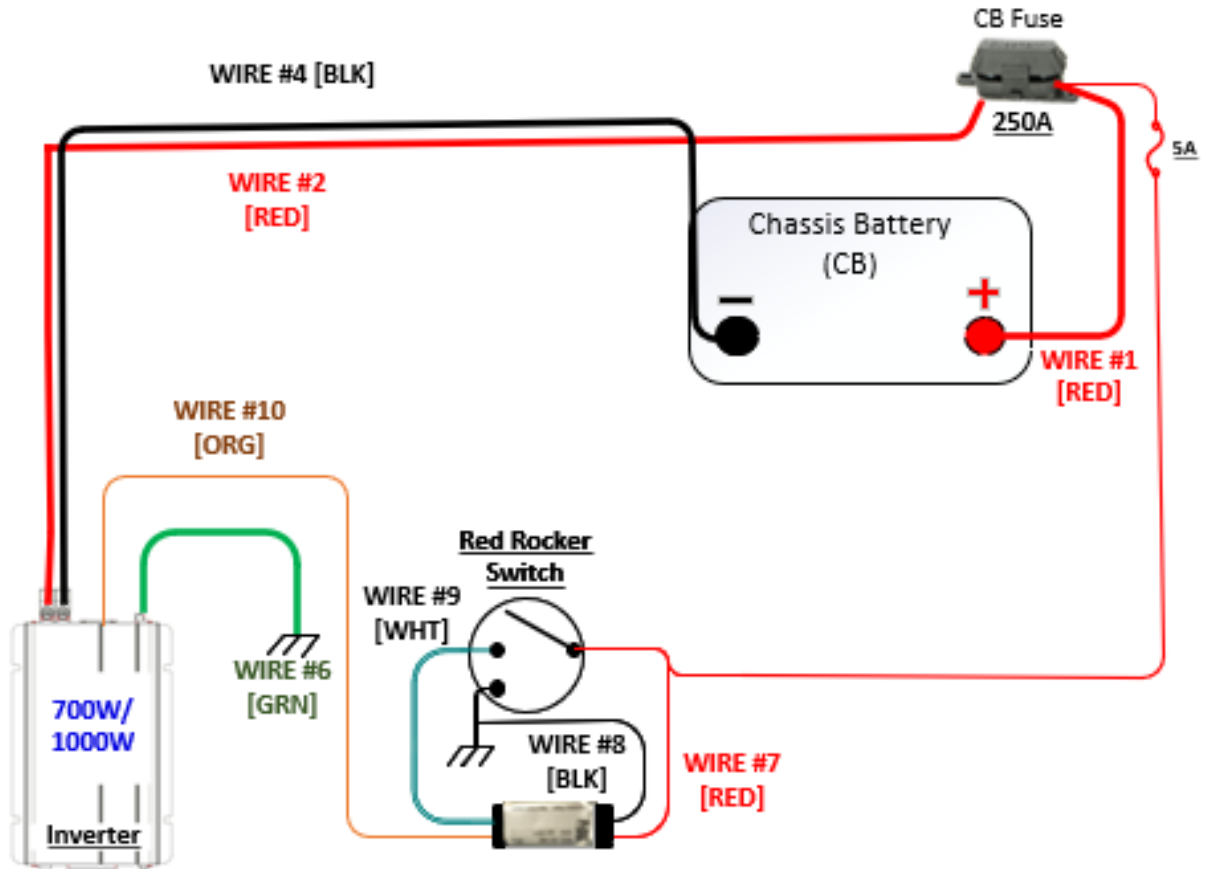
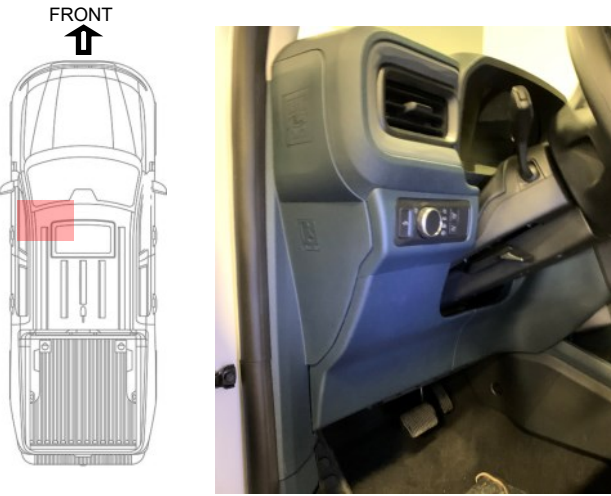

Figure 5-1: Complete Wiring Diagram [KIT 69834 [ICE]: 700/1000W]

Section 6: Vehicle Integration: Removing Trim in Preparation

Step 6-1. Remove Knee bolster Panel



- Pull off the knee bolster panel beneath the steering wheel.

Step 6-2. Pull back door seal



- Pull the door seal from the left drivers side IP along the front/leading edge of the opening edge– push this trim aside.

Step 6-3. Remove IP side trim

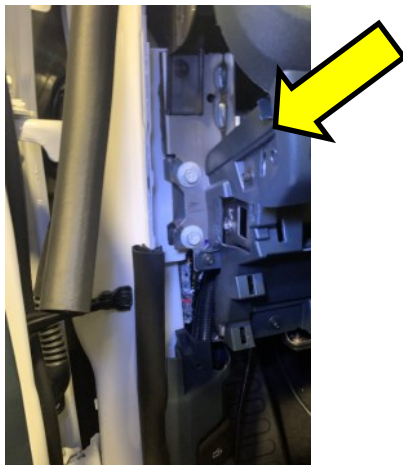

- Remove the side trim from the left drivers side IP.
- There is a Christmas tree fastener at the bottom of this piece, pull it out carefully with a trim tool to avoid damage.

Section 6: Vehicle Integration: Removing Trim in Preparation

Step 6-4. Release hood for later steps



- Release the hood (twice pull).

Step 6-5. Hood latch handle clip removal



- Remove the hood release lever by reversing clip out of the handle– the handle will pull straight off

Step 6-6. Driver's door trim removal



- Remove driver's side front door rocker trim

Section 6: Vehicle Integration: Removing Trim in Preparation

Step 6-7. Removing Lower B-Pillar trim

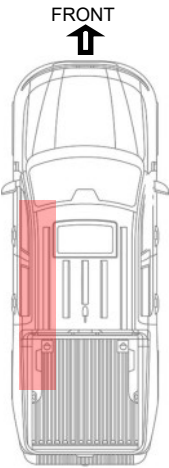

- Remove the B pillar lower trim piece next to the driver's seat [it may help to move seat forward]

Step 6-8. Releasing the seat buckle mount

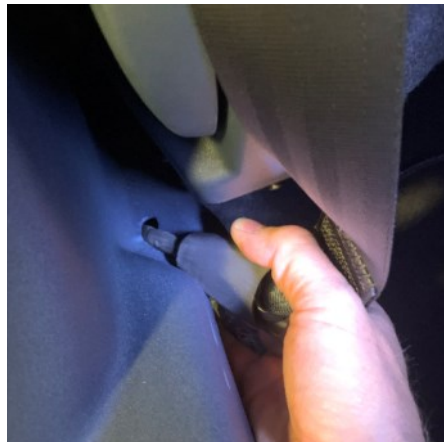

- The trim will be attached to the driver's seat belt buckle mount's cable. The cable of the buckle will pull out of the slot in the trim.

Step 6-9. Rear seat trim removal



- Lift rear bench seat to access under the seat storage area
- Remove driver's side rear door rocker trim. This exposes some of the door trim/ raceway that will hold the cables (White Plastic)

Section 6: Vehicle Integration: Removing Trim in Preparation

Step 6-10. Release plastic wire raceway cover

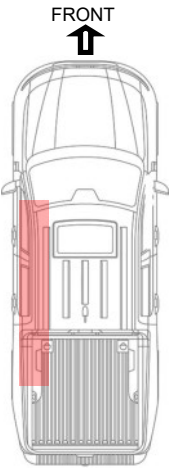

- Release cover the rocker panel hinged raceways at the drivers side front and rear seats

Step 6-11. Trim some of the forward raceway guide



- Cut a channel in the black plastic wire guide forward of the drivers seat raceway as shown

Step 6-12. Trimming plastic will allow better fit



- This will allow wires cables through later...

Section 6: Vehicle Integration: Routing Cables from Chassis Battery

Step 6-13. Find clutch cutout hole



- Go to footwell area of driver beneath the steering wheel– look for clutch cut-out grommet that gives access to the engine compartment.

Step 6-14. Remove the hole grommet and cut



- Pull out the grommet
- Slice a slot or oblong hole into the grommet.

Step 6-15. Begin to route cables to engine compartment

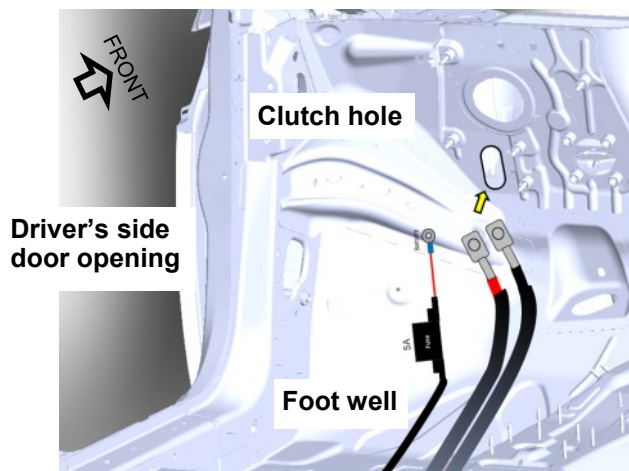

- Pull **WIRE#2, WIRE#4 , and WIRE#7** through the grommet about 4 feet.
- Bundle and tape together these wires.
- Push this same bundle of wire through the clutch hole.
- Orient it upward as it is fed through

Section 6: Vehicle Integration: Routing Cables from Chassis Battery

Step 6-16. Routing ends into engine area

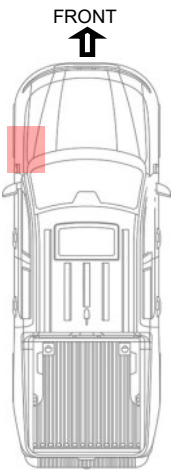

- Feed the same ends of **WIRE#2**, **WIRE#4** and **WIRE#7** (Red wire from remote switch) up through the clutch hole.
- Aim upwards towards behind the chassis battery– have an assistant pull the wires through a few feet.

Step 6-17. Chassis Battery Ground

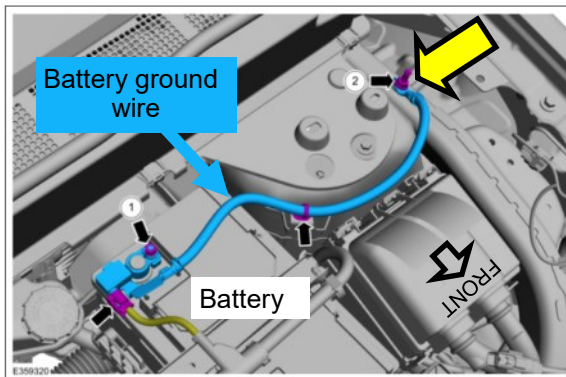

- Install **WIRE#4** onto chassis ground stud as shown with main battery ground.

Step 6-18. Connect WIRE#4 to chassis ground

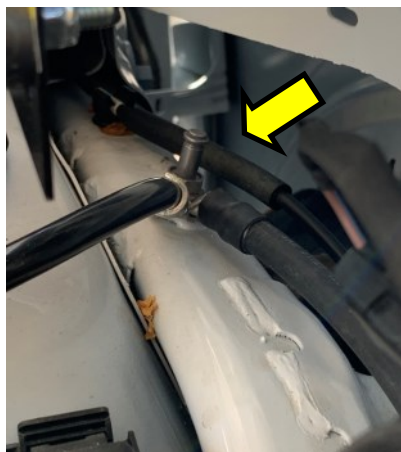

- Use a long socket and Torque according to spec (26 lb ft (35Nm))

Section 6: Vehicle Integration: Chassis Battery Fuse Installation

Step 6-19. Engine fuse holder bracket

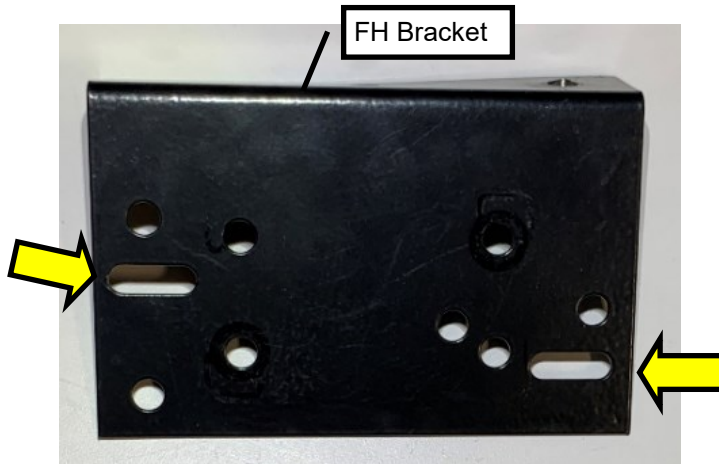

Caution: Make sure the fuse holder is mounted in the lowest holes from the bend.

- Please note that the fuse holder needs to be installed in the lowest set of slotted holes.
- This is in order to not interfere with the hood shutting

Step 6-20. Attach Chassis Battery Fuse to Fuse holder



- Use FAS0025 (Ref. NO.: 5) and FAS0029 (Ref. NO.: 6) to Install the Bussman fuse holder onto the 44918-B BRACKET, FUSE HOLDER (Ref. NO.: 17) and torque to 3Nm [+/- 0.5Nm] (27lb.in.) with a #2 Phillips and 3/8" wrench.
- Do not forget to install the yellow "do not jump start..." label beneath the fuse holder as it is attached.

Step 6-21. Fuse holder mounting point

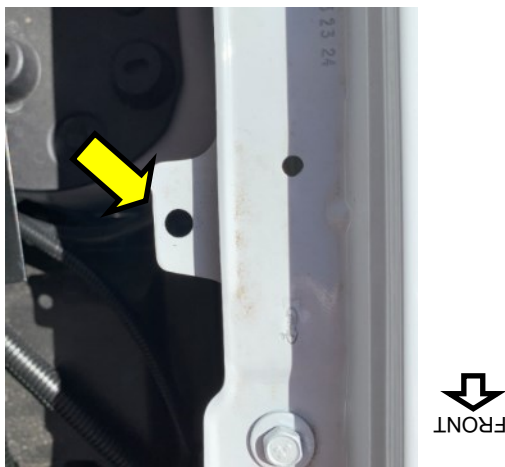
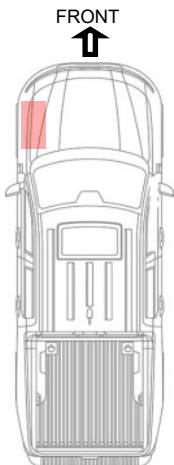

- Tighten the fuse holder onto the bracket holder located at the top edge of the engine compartment (see yellow arrow).

Section 6: Vehicle Integration: Chassis Battery Fuse Installation

Step 6-22. Fasten fuse holder

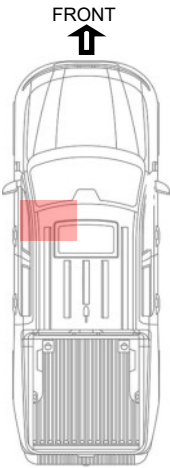

Caution: Make sure the fuse holder is mounted in the lowest holes from the bend.

- Use FAS0641 (Ref #2) and FAS0055 (Ref #10) and torque to 12Nm [\pm 1.8Nm] (106lb.in).
- Use a #2 Phillips and 7/16" Wrench to fasten.

Step 6-23. Install anti-rotate screw

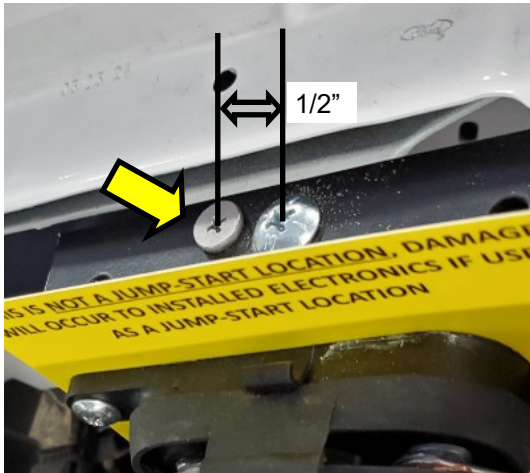

- Tighten the fuse holder onto the bracket holder located at the top edge of the engine compartment
- Measure 1/2" toward the back of the vehicle and drill in the tek screw to prevent the fuse holder from rotation
- Torque Tek screw FAS0148 (Ref #11) to 3Nm [\pm 0.5Nm] (27lb.in).

Step 6-24. Connect WIRE#1, WIRE#2 and WIRE#7



Caution: Do not insert fuse at this time

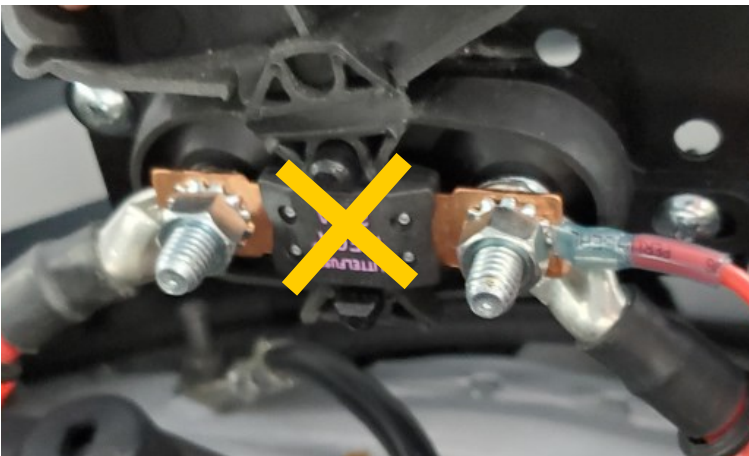

- Route **WIRE#2** then **WIRE#7** to the fuse holder as shown and temporarily attach to the fuse holder stud.
- Attach **WIRE#1** to the other forward side of the fuse holder—do not insert fuse at this time
- Do not insert the fuse at this point

Section 6: Vehicle Integration: Chassis Battery Fuse Installation

Step 6-25. Remove chassis battery cover

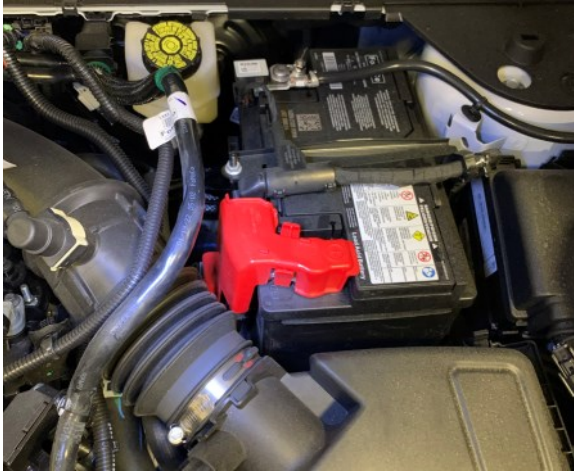
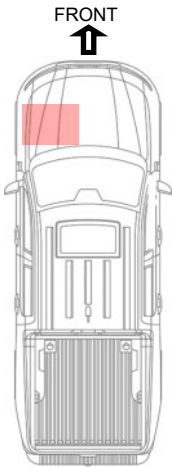

- Release the red plastic cover from the positive side of the battery

Step 6-26. Identify correct battery terminal

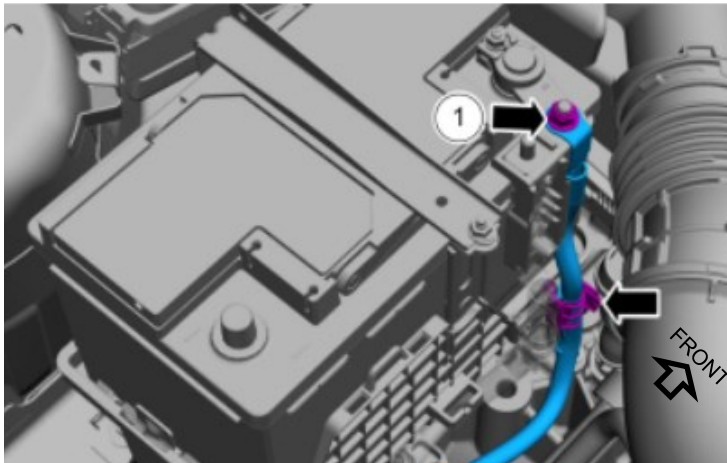

- Remove 13mm fastener on the battery busbar as shown

Step 6-27. Connect WIRE#1 to battery busbar



Caution: Be sure that other end of WIRE#1 is connected to CB Fuse holder



- Place **WIRE#1** onto the stud and re-fasten the 13mm nut at a torque of 106lbin (12Nm)
- Note (there may be other power feed ring terminals added to this stud)

Section 6: Vehicle Integration: Chassis Battery Fuse Installation

Step 6-28. Replace red terminal cover

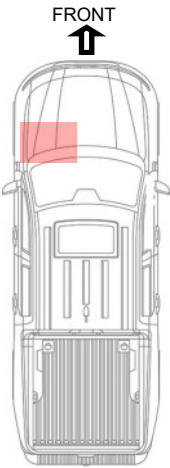

- Replace red plastic cover onto chassis battery
- A notch can be carefully cut into the plastic cover with snips to allow better fitment over the cable.

Step 6-29. Neatly route and clip engine cables



- Make sure all wires in the engine compartment are routed neatly—avoiding any moving parts. It may be appropriate to fasten to anchor points with cable ties.
- There is no fuse installed in the engine fuse holder yet (Yellow Arrow)

Step 6-30. Straighten and seal clutch hole grommet and cables

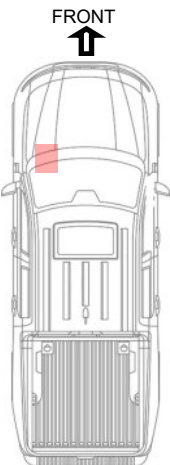

- Bring any slack in beneath the IP in the drivers side foot well.
- It will be a good time to apply a silicone sealant around the three looms.

Section 6: Vehicle Integration: Remote Switch Harness Layout

Step 6-31. PRE-ASSEMBLED 69834 Timer Harness Layout

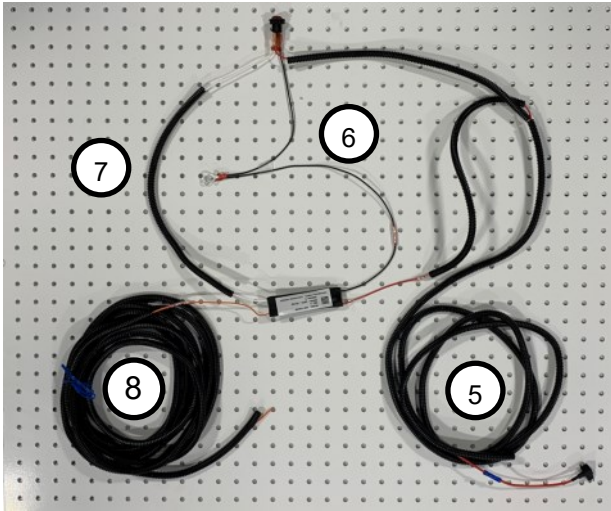

Diagram 6-31A: Remote Harness Layout



Be aware that the switch will not be connected until after the harness is installed and the knee panel is being installed.

- 5 BATTERY to SWITCH and TIMER, “WIRE #5”- RED wire, Black Corrugate, HAAT
- 6 GROUND WIRE to SWITCH and TIMER, “WIRE # 6” - BLACK wire, Ground
- 7 REMOTE SWITCH to TIMER “WIRE # 7” - WHITE wire, Black Corrugate, Switch Signal
- 8 TIMER to INVERTER “WIRE # 8” - ORANGE wire, Black Corrugate, Remote Signal

DIAGRAM 6-31: The 69834 Remote Switch Harness Diagram.

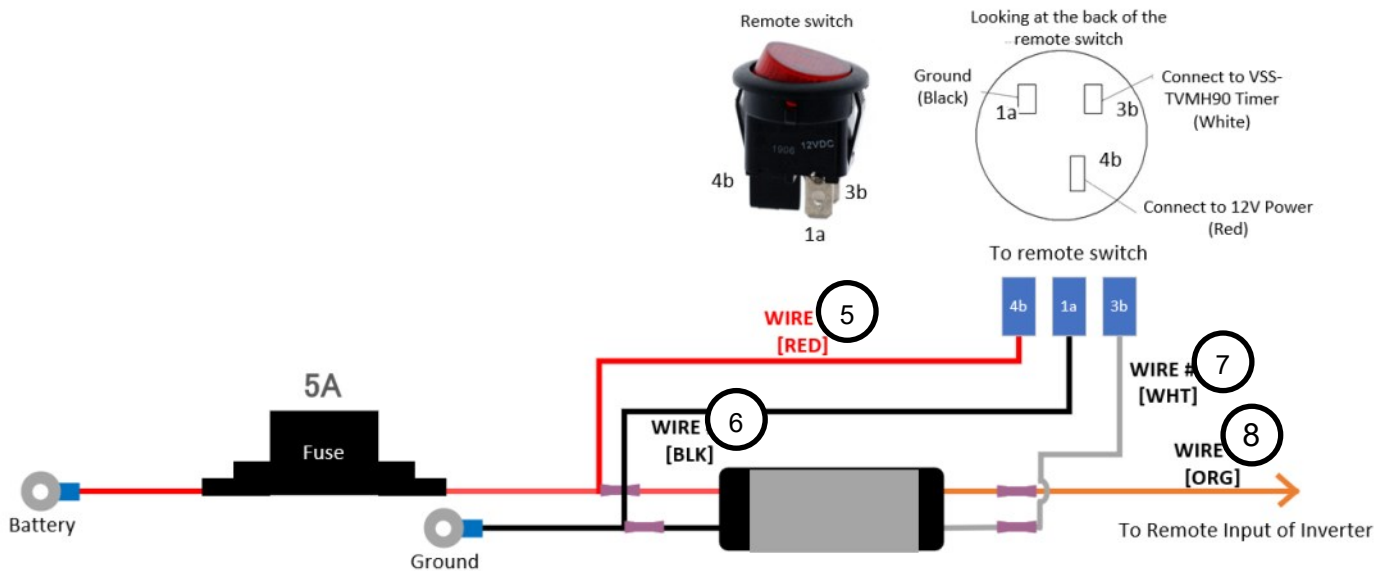

- A diagram of the remote switch and timer harness assembly is shown in image above.
- It is pre-assembled excluding the switch, which is separate.
- The remote switch will be installed in the panel under the steering wheel as shown in Step 6-14.
- The three spade connectors attached to color coded wire will be attached to the terminals of the switch after pulling them through the hole made in the knee bolster as shown above.

Section 6: Vehicle Integration: Remote Switch Harness Layout

Step 6-32. Preparation to Connect Remote Switch

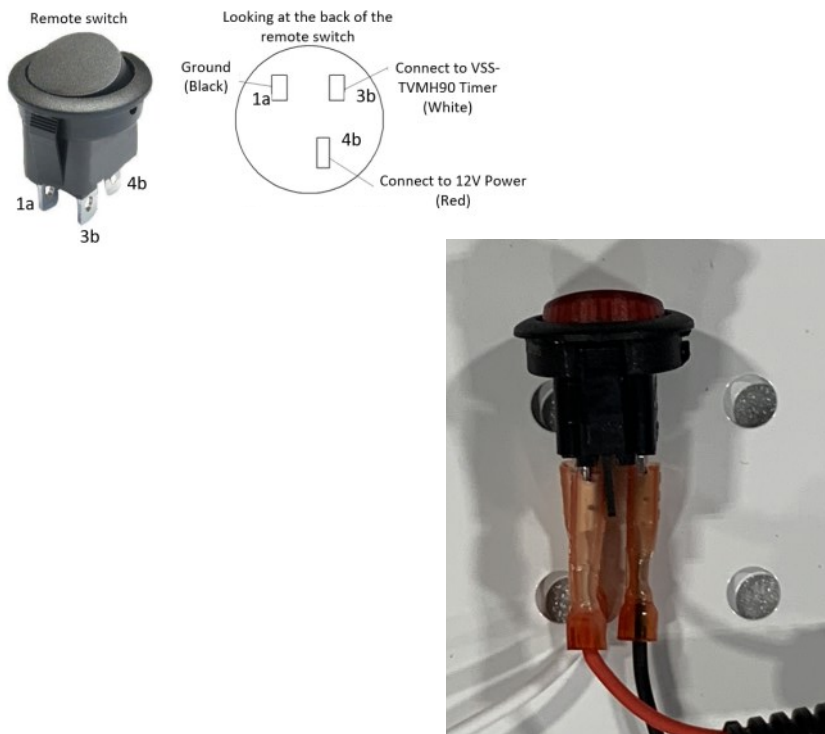
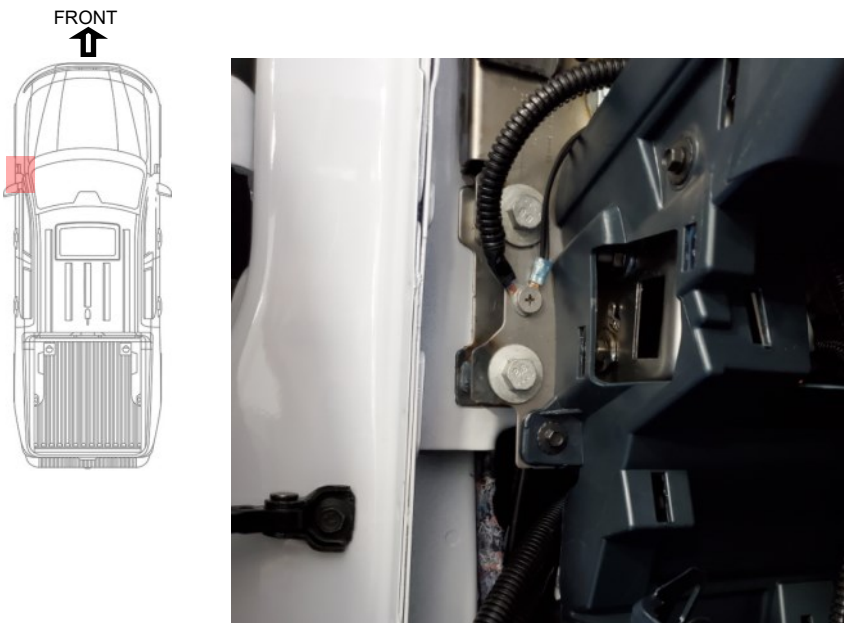

Diagram 6-32: KIT 69384 Remote Switch Connections

- The crimped on spade terminals of **WIRES #7, #8, and #9** will be pushed firmly onto the stakes of the provided switch (according to Diagram 6-10B) **after** being pulled through the switch hole drilled earlier in the knee bolster.

Step 6-33. Timer Switch ground



- The timer switch harness will be brought through the knee bolster frame to the location shown. Neatly route the ground to the left drivers side IP and locate steel sub framing.
- Set a Tek screw through this material in order to fasten the timer's ground wire to this grounded metal substructure. Torque Tek screw FAS0148 (Ref #11) to 3Nm [+/- 0.5Nm] (27lb.in).

Section 6: Vehicle Integration: Remote Switch Installation

Step 6-34. The three wire switch loom location

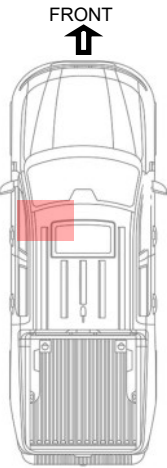

- Pull the switch terminals through the area shown in the IP. The timer switch harness will be brought through the knee bolster frame to the location shown.
- The timer module will be tucked behind the panel and fastened onto the existing wire harnessing structure with wire ties.

Step 6-35. Put switch hole in knee bolster

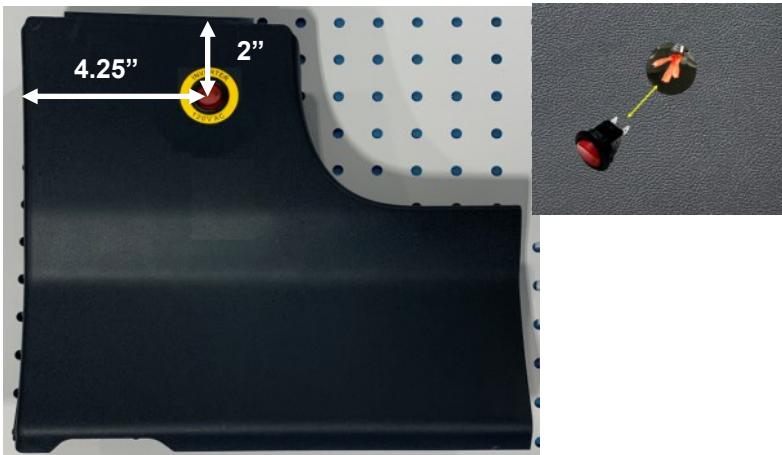

- On the removed panel (from Step 6-1)
- A hole diameter of 3/4" [19mm] is necessary to install the snap in switch [do not insert switch yet].
- The drill hole center of the switch location is 4.25" from left edge and 2" down from the top edge of the knee bolster panel.

Step 6-36. Insert & Connect the Remote Switch

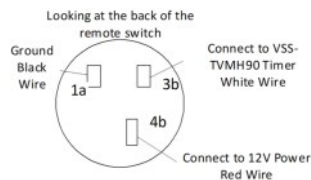

- Pull the three switch spade terminal wires through the knee bolster hole and connect according to wire color and stake label [1a (Black), 3b (White), 4b (Red)].
- Install the knee bolster after Orange **WIRE #8** is routed.
- Switch will light, but not function until the inverter is connected.

Section 7: Inverter Mounting and Cabling: Wire and Cabling

Step 7-1. Running power cables and remote wire

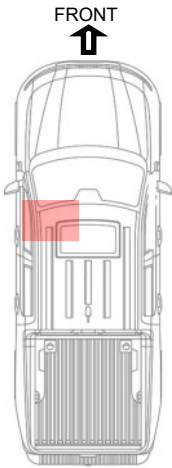

- Bring **WIRE#2**, **WIRE# 3**, and the **ORANGE WIRE#8** from driver's footwell area through this opening at the left side of the IP

Step 7-2. Routing along drivers door

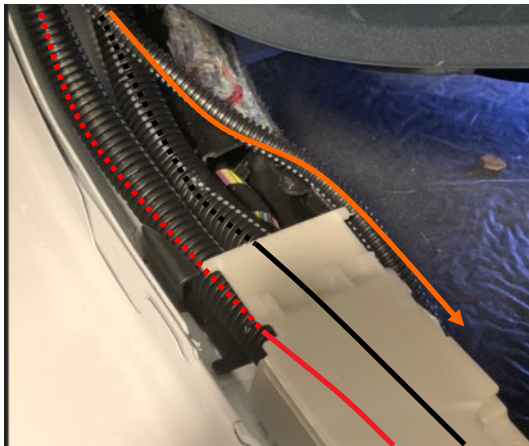

- Pull the carpet away from the driver's side rocker trim just enough to feed the orange **WIRE#8** backwards along the rocker towards the location of the Inverter installation

Step 7-3. Routing along drivers door



- The cable and Orange wire will follow this path

Section 7: Inverter Mounting and Cabling: Wire and Cabling

Step 7-4. Routing along rocker panel

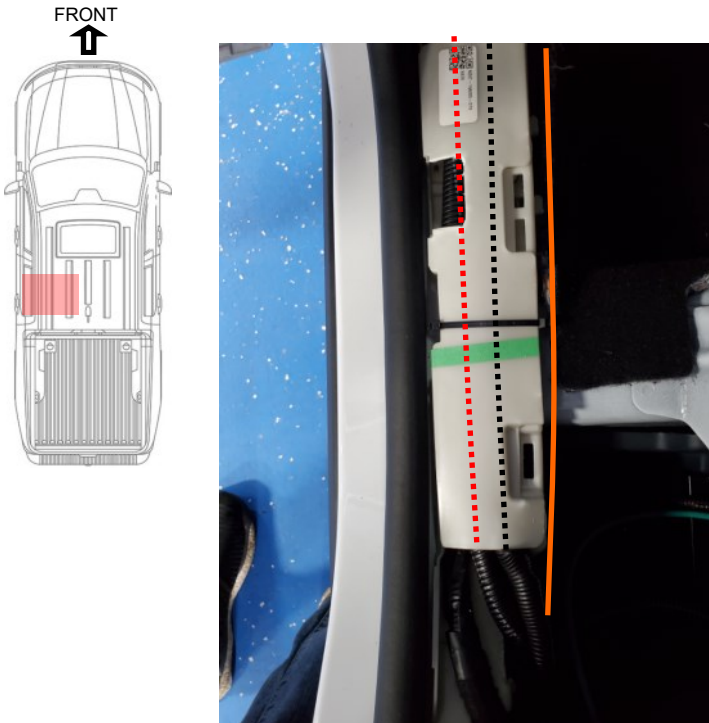

- The wires will follow this path.
- After power and ground cables are brought through wire raceway, arranged them so that the lid will snap shut.
- For extra close strength, it is advised to add a zip tie through the holes in the raceway over the lid for extra clamping on the wires within.

Step 7-5. Routing around pretensioner

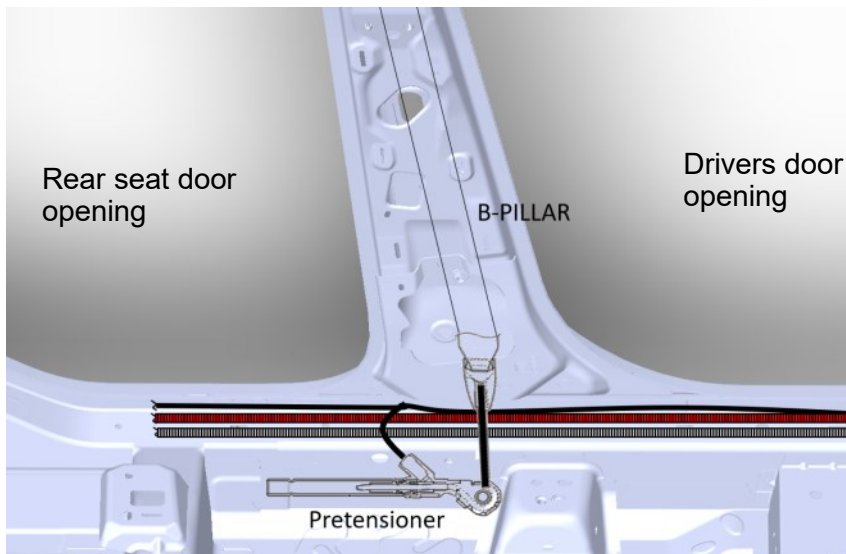

- When the cables approach the seatbelt pretensioner, they need to be kept away from the mechanism.
- The cables and orange wire will ride along the body sheet metal along the door thresholds.
- The cables will go beneath the connector wire of the pretensioner

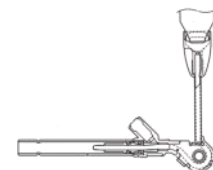

Section 7: Inverter Mounting and Cabling: Wire and Cabling

Step 7-6. Routing behind the seatbelt buckle

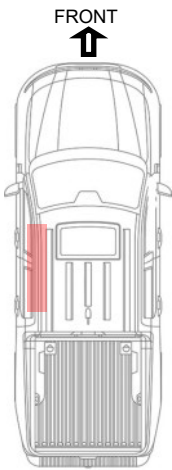

- Take the **WIRE#2, WIRE#3**, and orange wire and route it on the street side of the seatbelt pretensioner –
- There must be no interference with the pretensioner, so routing is critical here

Step 7-7. Be sure there will be no interference

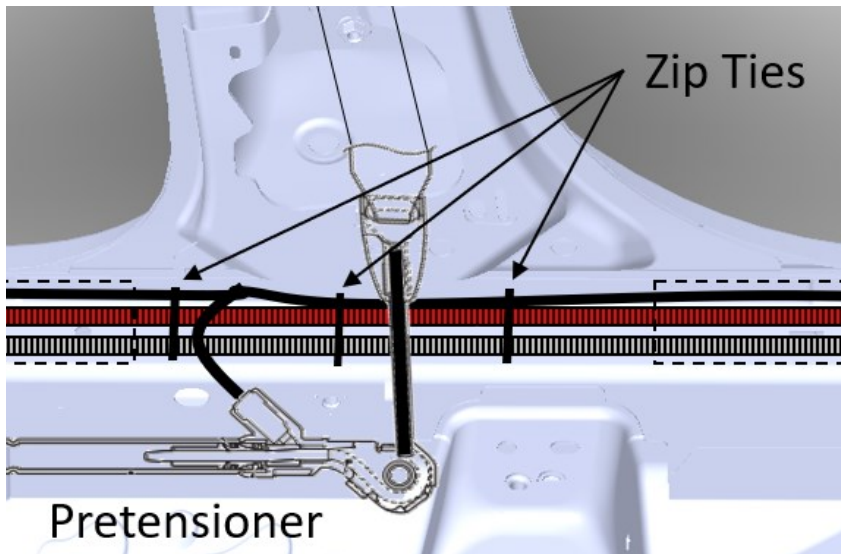

- Utilizing wire (zip) ties for making sure the wire is well bundled away from the pretensioner is important .

Section 7: Inverter Mounting and Cabling: Wire and Cabling

Step 7-8. Routing review

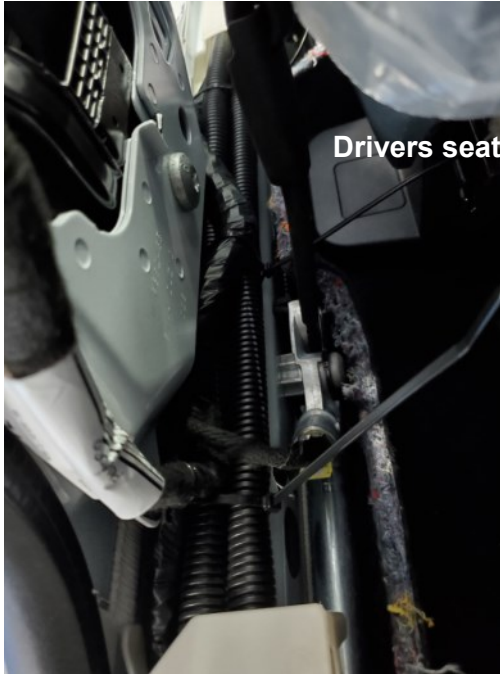
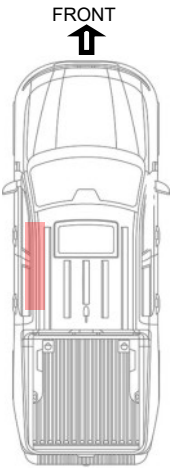

- View looking down the cables bundled from the rear seat.

Step 7-9. Routing review

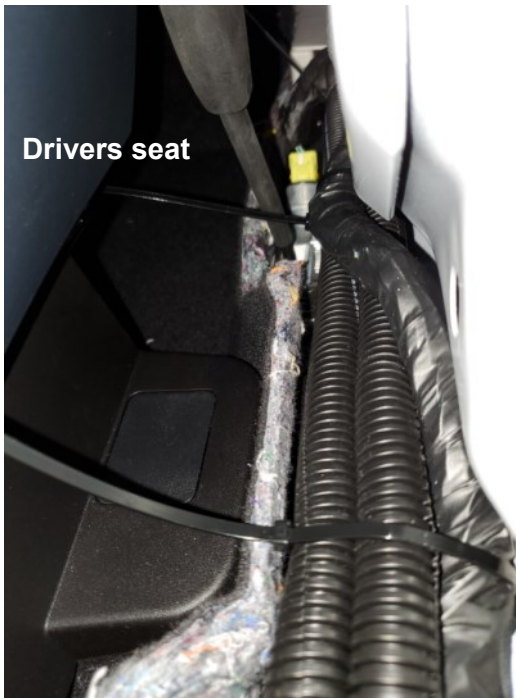

- View looking down the cables bundled from the drivers seat.

Section 7: Inverter Mounting and Cabling: Wire and Cabling

Step 7-10. Raceway adjustment

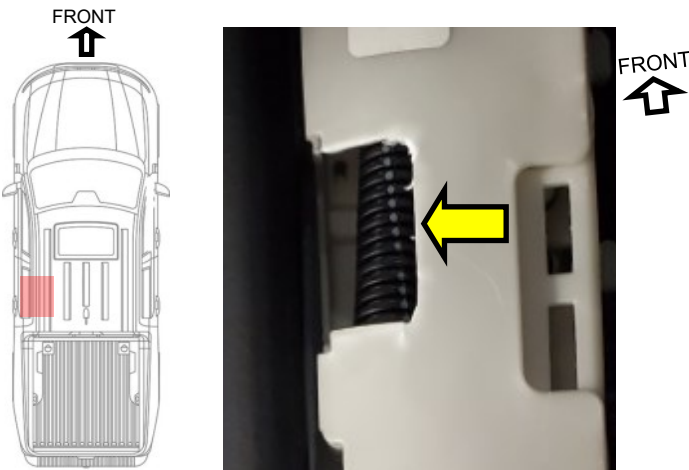

- Notice a plastic obstruction is removed from the white plastic rear wire raceway.

Step 7-11. Closing the raceway



- Press down the **WIRE#2, and WIRE#3** into the raceways and snap the lid in place. Feed a cable tie through the holes of the raceway to hold down the lid for extra reinforcement

Step 7-12. Trimming the rear raceway for access to under seat cavity



- Plastic from the rear seat raceway is also trimmed back so that the cabling can naturally turn out of the raceway into the area under the rear seat where the Inverter will be located.

Section 7: Inverter Mounting and Cabling: Wire and Cabling

Step 7-13. Routing wires toward Inverter



- Route the cables and orange **WIRE#8** in the area under the rear seat.
- Continue routing the **WIRE#2** and **WIRE#3** cables (from the front of the vehicle) under the rear seat. Leave them there for now.

Step 7-14. Reference Diagram Area of interest

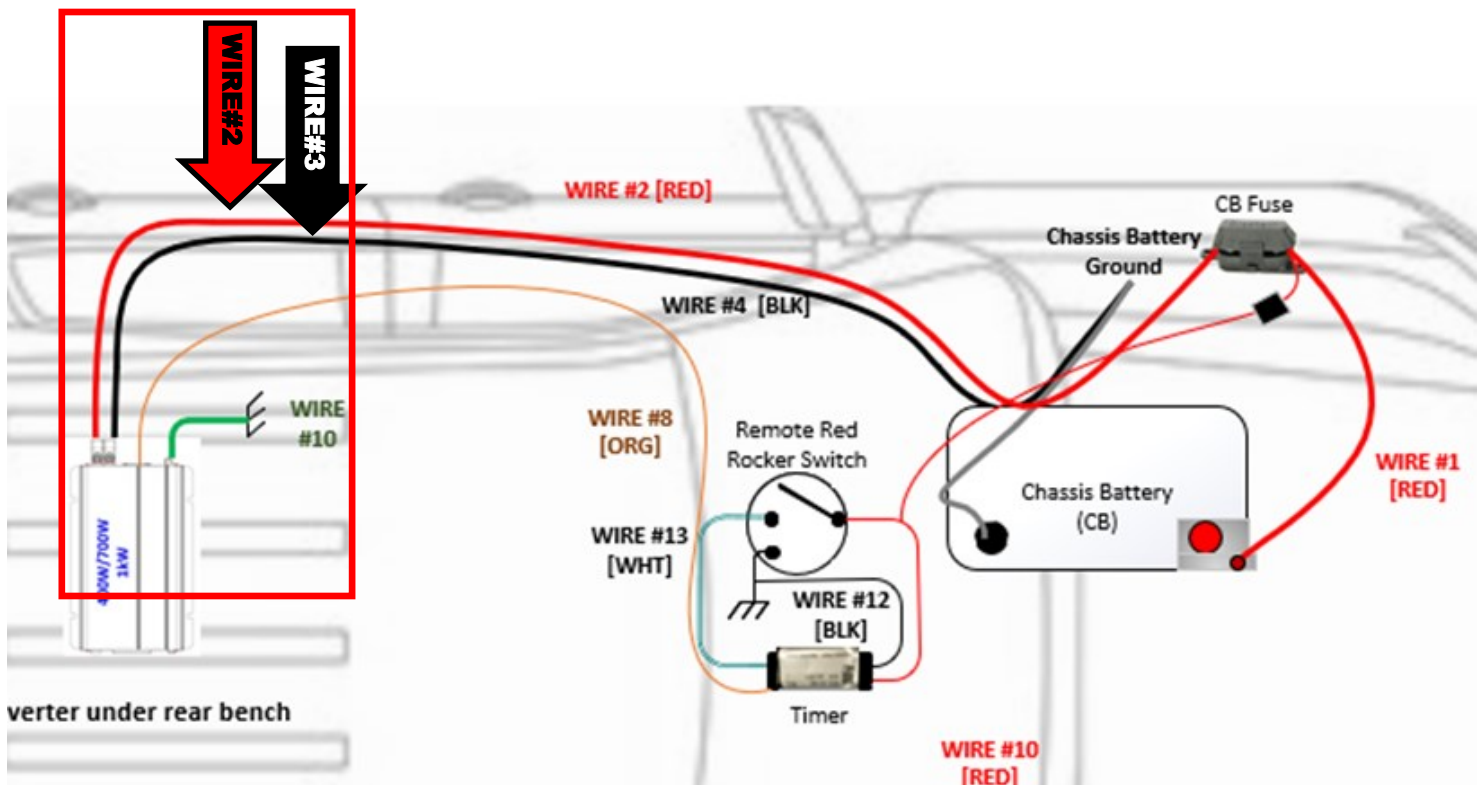

Section 7: Inverter Mounting and Cabling: Mounting

Step 7-15. Mounting Inverter

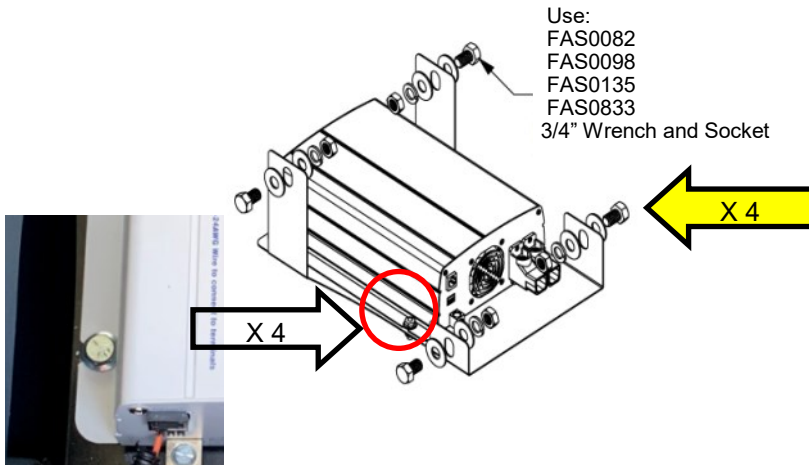

- The inverter will be mounted by its mounting flange holes to the metal inverter bracket (ex. White Arrow) with (4) FAS0055 and (4) FAS0018 torqued with a 7/16" socket to: 12Nm [+/- 1.8Nm] (106lb.in).
- Install the hanging fasteners (ex. Yellow Arrow) in the order shown. Do not tighten the hanging bolts until installed into under seat mounting points.

Step 7-16. Install Inverter

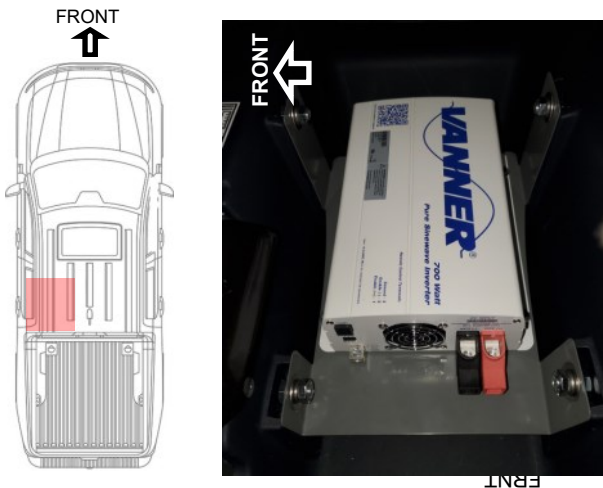

- Install the inverter w/bracket into its location and mounts beneath the rear seat as shown.
- Install the Inverter onto the plate using (4) FAS0055 and (4) FAS0018.

Step 7-17. Check Rocker Switch

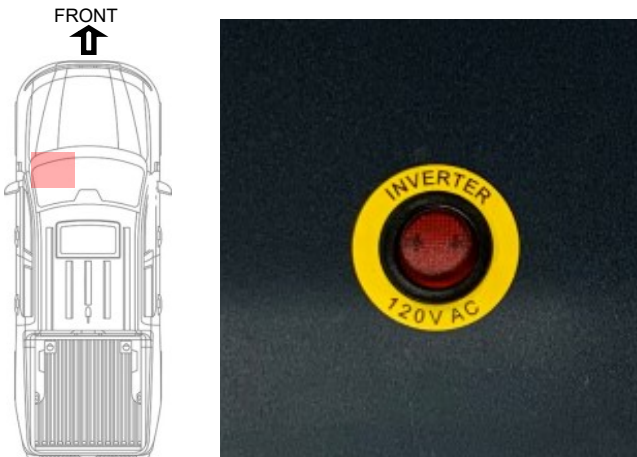

- Make sure the red rocker remote switch is off and the inverter switch is set to off.

Section 7: Inverter Mounting and Cabling: Wiring and Cabling

Step 7-18. 700 & 1000W Inverter Preparation



The inverter's screw terminals are difficult to

- Loosen the #3 Phillips (+) fasteners on terminals and remove them for the moment.

Step 7-19. Installation of Cables into Inverter

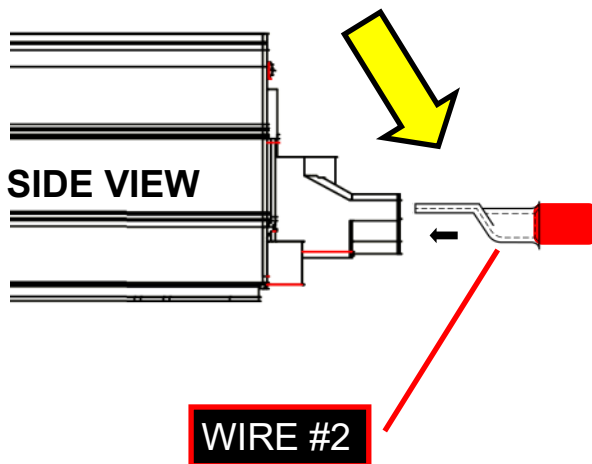

The lugs should fit squarely into the terminal covers and sit flat upon the terminal surface. They may need to be turned over.

- Bring **WIRE #2** and **WIRE #3** neatly to the terminals on the inverter.
- Be sure to orient the cable lug so that it fits squarely into the inverter terminal (flat side up).

Step 7-20. Installation of Cables into Inverter



Caution: All DC connections should be tightened to proper torque to avoid loosening during time in service.

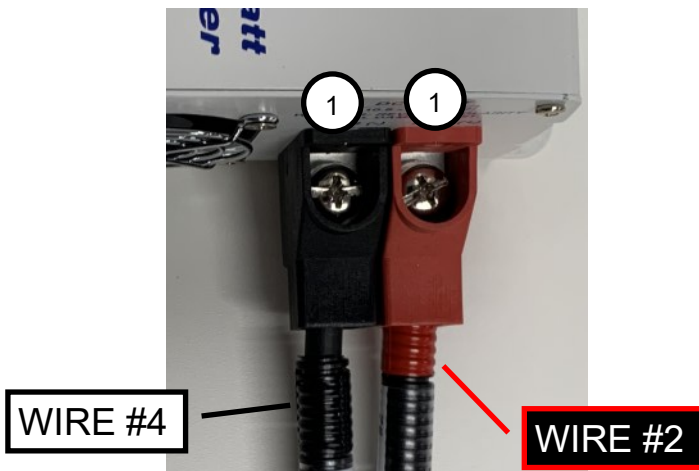

- Connect **WIRE#2** and **WIRE#3** cables to the Positive and negative terminals (REF#6) (respectively) on the inverter.

1

These connections shall be torqued to 12.4Nm [+/- 0.7Nm] (110 lb.in).

- Use wire ties to keep the wires from moving apart.

Section 7: Inverter Mounting and Cabling: Wiring and Cabling

Step 7-20. Inverter Chassis Ground Installation



Caution: All DC connections should be tightened to proper torque to avoid loosening during time in service.

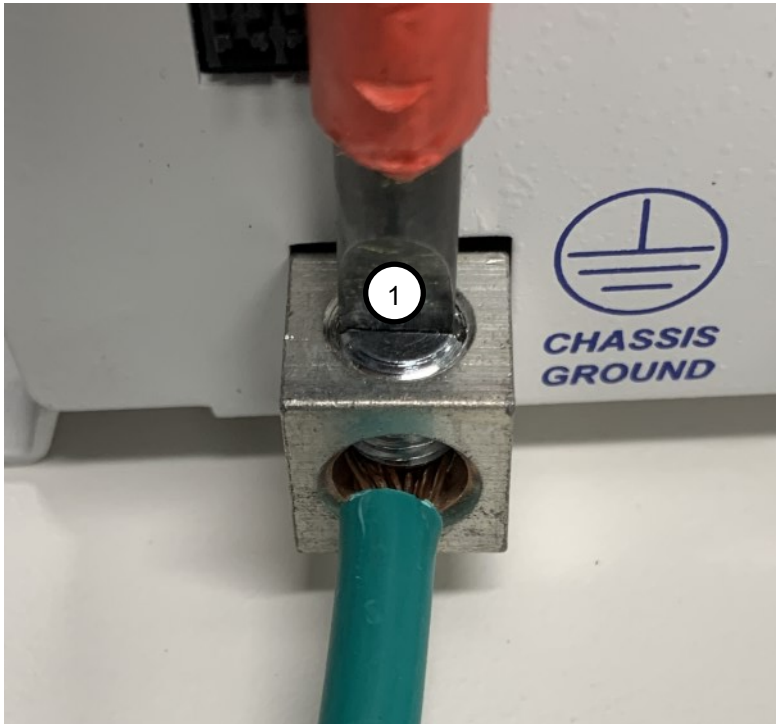

- The 8AWG GREEN Inverter ground **WIRE #4** has an end with the insulation pre-cut
- Remove the insulation and clamp into the Chassis Ground terminal.

① This connection (REF#6) shall be torqued to 12.4Nm [+/- 0.7Nm] (110 lb.in).

Step 7-21. Remote Wire Connection to Inverter

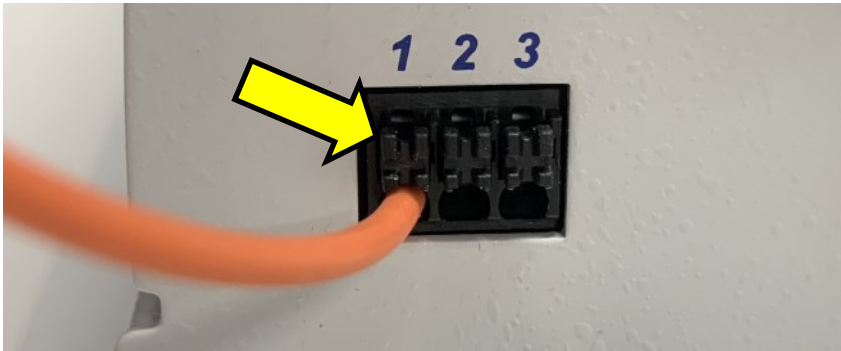

- The remote Orange WIRE #8 is length adjusted so there is not excessive extra length. It can also be coiled and fastened with wire tie.
- The Orange WIRE#8 is stripped about 3/8", twisted to avoid strays, and pushed into the #1 terminal in the black remote control header.
- If it must be released for any reason, push the square button above the terminal hole *and hold* to disengage the spring clamp, then pull the wire out.

Section 7: Inverter Mounting and Cabling: Wiring and Cabling

Step 7-22. Connect inverter ground to vehicle chassis



Inverter chassis safety ground is put here because most of the areas on the floor are no drill zones

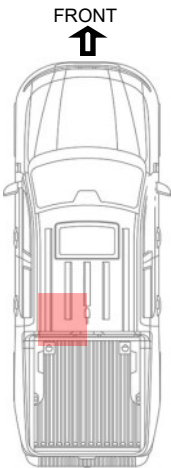

- Pull the release strap on the rear seat back and fold it forward.
- Observe the bracket in the cab/bed wall - see photo to the left.
- Install the green case-ground WIRE#4 as shown using FAS0641 (Ref #10) .

Step 7-23. Close-up of Ground wire mount

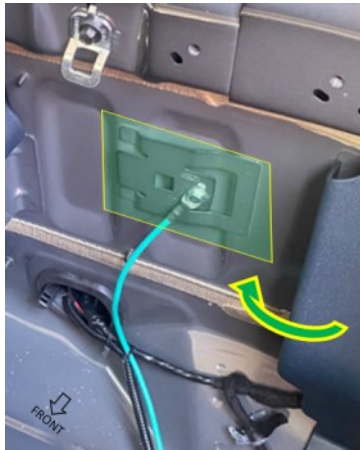

- FAS0641 (Ref #10) is a self tapping screw
- Use a 7/16 impact driver and tighten to 12Nm [\pm 1.8Nm] (106lb.in).

Step 7-24. Wiring Complete on Inverter



- At this point the wiring is completed on the inverter.
- Wiring can be organized, routed and clipped after cables are installed onto the battery

Section 8: Settings & Important Labeling

Step 8-1. Inverter Front Face

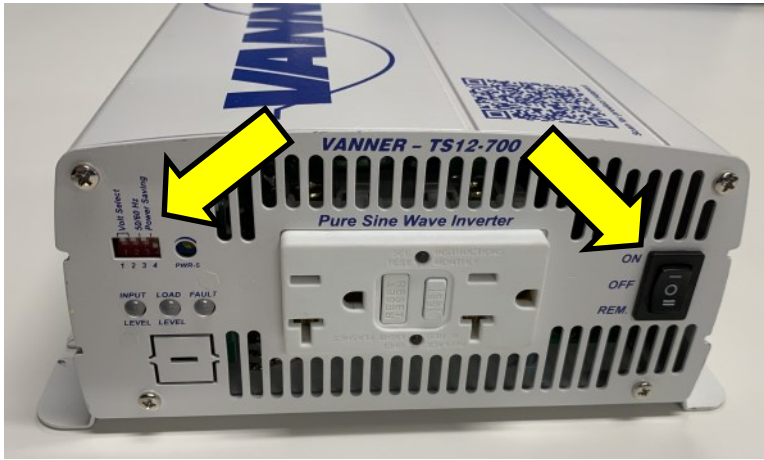

- This side of the inverter will face the center of the vehicle.
- On the front side of the inverter, insure the setting switches are correct...

Step 8-2. Function Switches

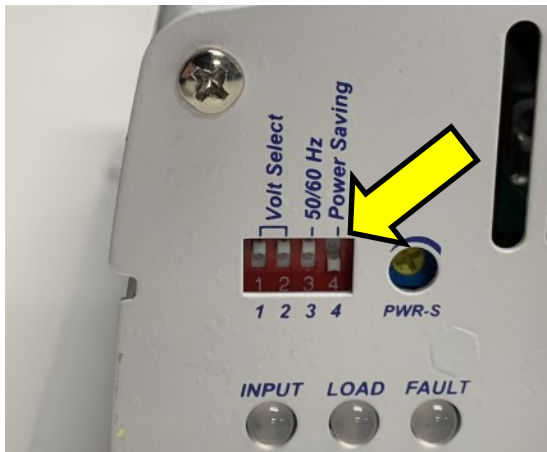

- The inverter function switches should be set to:
- 1-UP/2-UP/3-UP/4-Down [120V, 60Hz, with power saving OFF].

Step 8-3. Remote Switch Confirmation

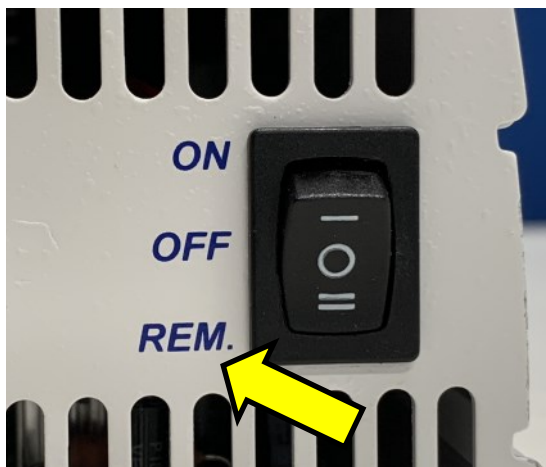

- The Inverter switch must be switched to "REM." (remote) to avoid inadvertent discharge of the battery.

Section 8: Settings & Important Labeling

Step 8-4. Apply Remote Inverter Switch Label (KIT 69834)

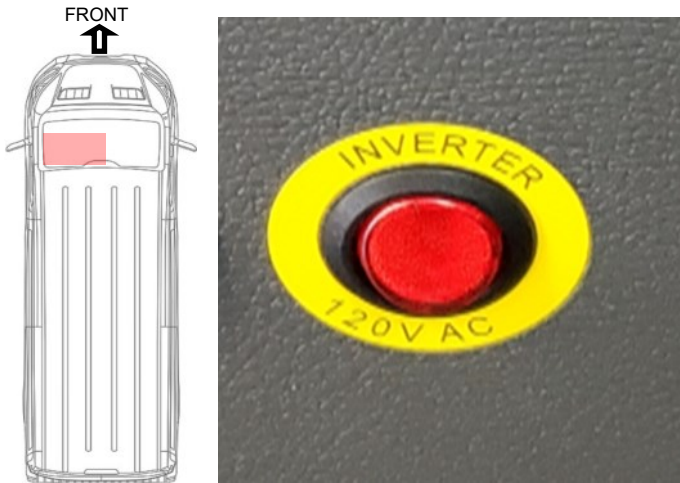

- Install the circular “INVERTER 120V AC” label at the red remote switch on the knee bolster panel.

Step 8-5. Apply Remote Inverter Switch Label





- Install the Blue Notice Label on the side of the inverter that is facing up after installation.

NOTICE
The power switch on this unit MUST be left in the REM (REMOTE) position to ensure correct operation of the inverter system. Changing the position of the switch can deplete the OEM batteries and require a jumpstart.

Section 9: Test and Check:

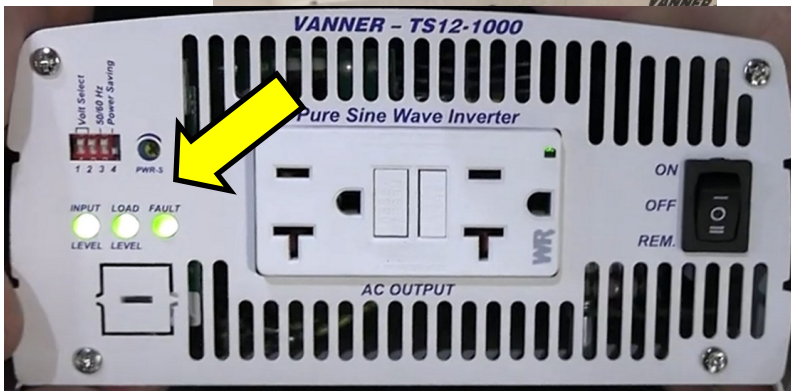
Step 9-1. Test the inverter function



 Warning: Make sure all AC connections are made appropriately before power up.

Test: Verify Inverter Powers Up

- Ensure the INVERTER power switch is set to “REMOTE” [Grey Arrow]
- Start the engine or turn ignition to “ON” position.
- Turn on the remote inverter switch in the dash.

What to expect:

- Verify all three round green LEDs light up green with nothing plugged in [See Yellow Arrow].
- If any of the LEDs are not Green, turn off the system and check all wiring.

Step 9-2. Check GFCI Operation

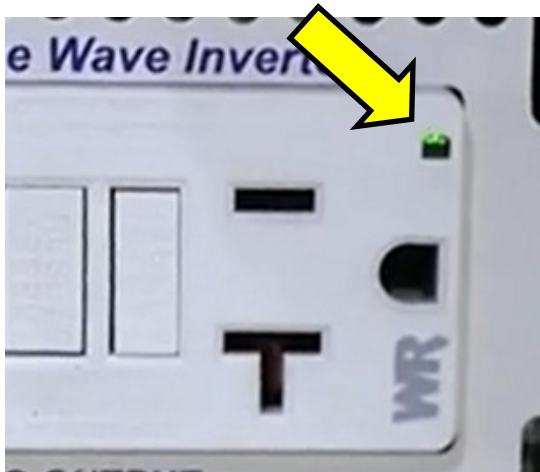

•Test: Verify GFCI Light is Green.

- While the inverter is powered, confirm the GFCI green light is on. Again- nothing should be plugged in.
- What to expect:
- If the light is Green, go to the next step
- If the light is red, push the GFCI RESET button. This should reset the device to green.

Step 9-3. Test the inverter power output



Test: Insert Inverter Output.

- **Plug in** any accessories such as power strips included with the kit.
- Utilize and extension cord with the Voltage meter into one of the outlets on the inverter. Alternately a GFCI outlet Tester will indicate any faults.

What to expect:

- The power output should be at correct voltage and polarity. A reading of 114Vac – 122Vac is expected.
- If voltage is not in that range please STOP and notify Team Lead.

Section 9: Test and Check:

Step 9-4. Routing and Clipping



- Turn off dash switch for transportation and leave the black inverter mounted switch in “REM”.
- Using the supplied wire ties make sure all wiring is secured and clear of sharp objects, moving parts, and heat sources.
- Ensure all trim removed in previous steps is secure and neat.

**INSTALLATION INSTRUCTIONS
HAVE FINISHED**

Section 10-A: Fleet Appendix-Wiring Diagrams

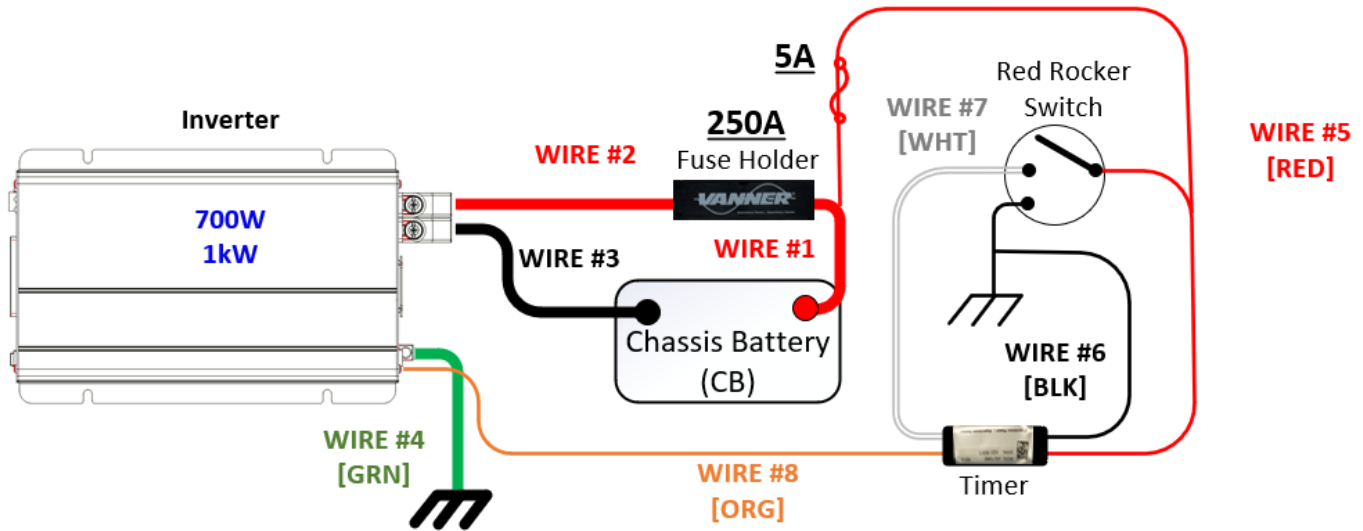

Figure 10-1: Complete Wiring Diagram [KIT 69834 [ICE]: 700/1000W]

Section 10-A: Fleet Appendix– Tools Needed



1. Insulated Splice Crimper
2. Wire Strippers
3. Diagonal Cutters
4. Plastic Trim Tool
5. Drill driver
6. Measuring tape
7. Phillips Bit with Bit holder
8. 3/4" Hole or Step Drill (Unibit)
9. Medium and Small (-) Screwdriver
10. Large #3 Phillips (+) Screwdriver
11. Sockets:
 - 8mm
 - 10mm
 - 5/16"
 - 3/8"
 - 7/16"
 - 1/2"
 - 13mm
 - Socket driver and extensions
12. Torque Wrench [~8-20Nm range]
13. Tin Snips
14. #3 Philips (+) & Medium slotted torque socket
15. Marker [Not Shown]

Figure 10-2: Tools Needed for Installation

Figure 12-3: Tools Needed for Installation

Section 10-A: Fleet Appendix– Additional Notes

NOTES:

- Battery Negative is not disconnected for these procedures. For safety it is generally recommended, but Ford BBS suggests not unhooking unless the battery is being changed.
- Only insert large MEGA fusing when ready to check functionality of the system after it is install.
- Be sure the MEGA fuse is correct size according to Inverter Cabling Kit PPDS.

DC Input Side Panel Wiring Diagram:

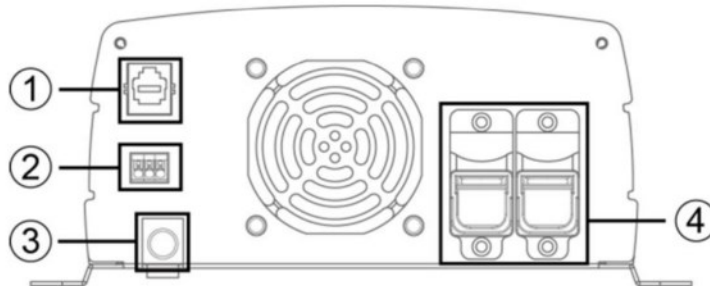

TS-700W and TS-1000W

Model	TS Series
①	Factory Port
②	Remote control black terminal
③	Chassis ground
④	DC input connector

Figure 10-3: Inverter Wiring Connections

Section 10-A: Fleet Appendix- Kit Fasteners and Torque Table

Torque Table for KIT 69834 [ICE]: 700/1000W

ITEM NO.	ASC PN	Description	PCS	Torque Range	Use Wrench or Size
2	FAS0055	Nut, Hex Flange, Nylock 1/4-20	5	12Nm [+/- 1.8Nm] (106lb.in).	7/16"
3	FAS0018	SCREW,HH SFLNG 1/4-20X.62 ZP	4	12Nm [+/- 1.8Nm] (106lb.in).	7/16"
10	FAS0641	SCREW,HH TEK 1/4-20X.7 ZP	1	12Nm [+/- 1.8Nm] (106lb.in).	7/16"
4	6105169AA	NUT, M8,FUSE BOX,SPR	1	10Nm (89 lb.in)	13mm
11	FAS0148	Screw, Self Drill/Tap, Pan Ph. Hd., #10x0.5, NI-ZN	2	3Nm [+/- 0.5Nm] (27lb.in).	#2 Phillips
12	FAS0062	SCREW,THP 1/4-20X.75 G5 ZP	1	3Nm [+/- 0.5Nm] (27lb.in).	#2 Phillips

Ref. NO.	ASC PN/Function	Description	PCS	Torque Range	Use Wrench or Size
6	Inverter +/- Terminals	Phillips and slotted screws	Three (3) Positions	12.3Nm [+/- 0.7Nm] (9.5 lb.ft).	#3 Phillips and 1/4" Standard driver bits

Other Fasteners in Vehicle

7	Battery positive post clamp fastener	10mm Nut	1	12Nm [+/- 1.2Nm] (106 lb.in).	10mm NUT
8	CB Negative Battery Cable to Chassis	13mm hex bolt	1	35Nm [+/- 1 Nm] (26 lb.ft).	13mm Nut

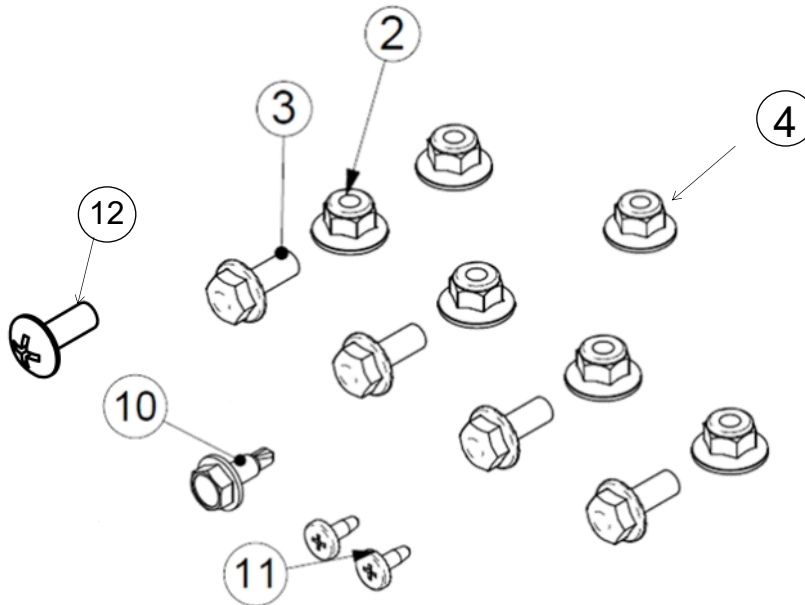

PART NUMBER

13905-0

ITEM DESCRIPTION: WIRE TIE, NYLON 40Lb, 8.5" BLACK



MANUFACTURER: WAYTEK, INC. or equivalent
MANUFACTURERS PART NUMBER: 21093M or 21093C

SPECIFICATIONS: STANDARD CABLE TIE
 BLACK, NYLON
 8-1/2" LONG
 TENSILE STRENGTH: 40.0 LBS
 21093M = 1,000 quantity
 21093C = 100 quantity

SPECIAL NOTES: PART NUMBER IS BLACK.

SUPPLIED BY: THIS ITEM IS ADRIAN AVAILABLE!

PURCHASED PRODUCT DATA SHEET (PPDS)

THIS DRAWING/INFORMATION IS THE PROPERTY OF ADRIAN STEEL COMPANY AND IS NOT TO BE USED IN ANY MANNER THAT IS DETRIMENTAL TO THE INTEREST OF ADRIAN STEEL. COPYRIGHTS AND OR PATENTS THAT MAY BE THE PROPERTY OF APPLICABLE OWNERS MAY PROTECT INFORMATION AND/OR DRAWINGS OF SUPPLIED PRODUCTS.



ADRIAN STEEL
VAN AND PICKUP EQUIPMENT

906 JAMES STREET
ADRIAN, MI 49221
517-265-6194
WWW.ADRIANSTEEL.COM



CAUTION

WHEN INSTALLING EQUIPMENT IN OR ON VEHICLES CHECK FOR FUEL TANKS, FUEL LINES, CONTROL LINES AND ELECTRICAL WIRING BEFORE DRILLING! ALWAYS USE DRILL BITS WITH INTEGRAL STOPS WHENEVER POSSIBLE!

DRAWN BY
MDG

DATE DRAWN
10/26/2006

ECN NUMBER
18021

ECN DATE
11/13/2015

PART WEIGHT
0.01 LBS.

REV. LEVEL
D

PART NUMBER
13905-0

PART NUMBER

26618-0

ITEM DESCRIPTION: SILICONE, 1oz. TUBE



SPECIFICATIONS: SU5005 RTV SILICONE
1oz. TUBE
CLEAR OR EQUIVALENT
SELF PIERCING CAP

SPECIAL NOTES:

SUPPLIED BY: THIS ITEM IS ADRIAN AVAILABLE!

PURCHASED PRODUCT DATA SHEET (PPDS)

THIS DRAWING/INFORMATION IS THE PROPERTY OF ADRIAN STEEL COMPANY AND IS NOT TO BE USED IN ANY MANNER THAT IS DETRIMENTAL TO THE INTEREST OF ADRIAN STEEL. COPYRIGHTS AND OR PATENTS THAT MAY BE THE PROPERTY OF APPLICABLE OWNERS MAY PROTECT INFORMATION AND/OR DRAWINGS OF SUPPLIED PRODUCTS.



ADRIAN STEEL
VAN AND PICKUP EQUIPMENT

906 JAMES STREET
ADRIAN, MI 49221
517-265-6194

WWW.ADRIANSTEEL.COM

CAUTION

WHEN INSTALLING EQUIPMENT IN OR ON VEHICLES CHECK FOR FUEL TANKS, FUEL LINES, CONTROL LINES AND ELECTRICAL WIRING BEFORE DRILLING! ALWAYS USE DRILL BITS WITH INTEGRAL STOPS WHENEVER POSSIBLE!

DRAWN BY
JLC

DATE DRAWN
7/21/2001

ECN NUMBER
16551

ECN DATE
7/22/2014

PART WEIGHT
0.02 LBS.

REV. LEVEL
C

PART NUMBER
26618-0

PART NUMBER

26618-0

ITEM DESCRIPTION: SILICONE, 1oz. TUBE



SPECIFICATIONS: SU5005 RTV SILICONE
1oz. TUBE
CLEAR OR EQUIVALENT
SELF PIERCING CAP

SPECIAL NOTES:

SUPPLIED BY: THIS ITEM IS ADRIAN AVAILABLE!

PURCHASED PRODUCT DATA SHEET (PPDS)

THIS DRAWING/INFORMATION IS THE PROPERTY OF ADRIAN STEEL COMPANY AND IS NOT TO BE USED IN ANY MANNER THAT IS DETRIMENTAL TO THE INTEREST OF ADRIAN STEEL. COPYRIGHTS AND OR PATENTS THAT MAY BE THE PROPERTY OF APPLICABLE OWNERS MAY PROTECT INFORMATION AND/OR DRAWINGS OF SUPPLIED PRODUCTS.



ADRIAN STEEL
VAN AND PICKUP EQUIPMENT

906 JAMES STREET
ADRIAN, MI 49221
517-265-6194

WWW.ADRIANSTEEL.COM

CAUTION

WHEN INSTALLING EQUIPMENT IN OR ON VEHICLES CHECK FOR FUEL TANKS, FUEL LINES, CONTROL LINES AND ELECTRICAL WIRING BEFORE DRILLING! ALWAYS USE DRILL BITS WITH INTEGRAL STOPS WHENEVER POSSIBLE!

DRAWN BY
JLC

DATE DRAWN
7/21/2001

ECN NUMBER
16551

ECN DATE
7/22/2014

PART WEIGHT
0.02 LBS.

REV. LEVEL
C

PART NUMBER
26618-0

PURCHASED COMPONENT KEY FEATURES

DESCRIPTION OF REQUIREMENTS

DIMENSIONAL REQUIREMENTS (AS SHOWN ON DRAWING)

N/A

LOAD/RATING REQUIREMENT

N/A

MATERIAL REQUIREMENT

N/A

PACKAGING REQUIREMENT

N/A

OTHER REQUIREMENTS

Input Voltage: 12VDC 10.5V - 16.5V) **Continuous Output Power:** 700w (+/-3%) **Output Voltage:** 100/110/115/120 VAC (+/-5%) (Dip Switch Selectable)
Output Waveform: Pure Sign Wave (THD<5%@ normal load)
Operating Temp: -25C to approx. 40C
Safety Standard: Certified UL 458 (UL only for GFCI)
SURGE RATING 150% OF CONTINUOUS POWER FOR 3 SECONDS
EMC STANDARDS FCC CLASS B: TS400, TS700, TS1000, AND TS1500
FCC CLASS A: TS2000 AND TS3000
EFFICIENCY 90%-93%
STANDBY RECOVERY FIVE SECONDS

INVERTERS CAN BE EITHER VANNER OR HAVIS, BOTH ARE DEPCITED HERE. VANNER HAS REBRANDED TO HAVIS, SO THE "VANNER" INVERTER IS BEING PHASED OUT.



THIS DRAWING IS THE PROPERTY OF ADRIAN STEEL COMPANY AND IS NOT TO BE USED IN ANY MANNER DETRIMENTAL TO THE INTERESTS OF ADRIAN STEEL COMPANY

TOLERANCES & INSPECTION

UNLESS OTHERWISE SPECIFIED

ALL BEND ANGLES ARE 90 DEGREES

ALL DIMENSIONS ARE IN INCHES.

REFERENCE DIMENSIONS (X.XXX)

DO NOT REQUIRE INSPECTION

FEATURES	HOLES/SLOTS	ANGLES
0.0 = ± .125	0.0 = ± .062	0° = ± 2°
0.00 = ± .062	0.00 = ± .031	0.0° = ± 1°
0.000 = ± .031	0.000 = ± .015	

Material Thickness: per ASTM Std.
Weld Callouts per AWS

RELEASE & REVISIONS

INITIAL ECN: **22984**

CURRENT ECN: **29480**

ECN DESCRIPTION:

ADD HAVIS INVERTER IMAGE

REVISED BY: **C.GILBERT**

PURCHASED COMPONENT

REFERENCED SUPPLIER AND/OR MANUFACTURER
VANNER/HAVIS

REFERENCED SUPPLIER AND/OR MANUFACTURER PART NUMBER
TS12-700

COLOR (ONLY LIST IF COLOR SPECIFIC)

COMMODITY ITEM (Y/N) (YES = ALL DIMENSIONS AND NOTES ARE REFERENCE)
(NOTE: DIMENSIONS AND FEATURES MAY VARY FOR A COMODITY ITEM.)

NO

PRINTED DOCUMENT IS UNCONTROLLED

Sheet 1 of 1

PART / PRODUCT IDENTIFICATION



ADRIAN STEEL

ADRIAN STEEL COMPANY
906 JAMES STREET, ADRIAN, MI 49221

REVISION LEVEL

B

MAT'L USED:

DESIGNED BY: **MJF**

DESCRIPTION:

INV TS12-700

WEIGHT (Lbs.):

6

SEGMENT CODE:

EIN

PART NUMBER: **56904**

PURCHASED COMPONENT KEY FEATURES

DESCRIPTION OF REQUIREMENTS

DIMENSIONAL REQUIREMENTS (AS SHOWN ON DRAWING)

N/A

LOAD/RATING REQUIREMENT

N/A

MATERIAL REQUIREMENT

N/A

PACKAGING REQUIREMENT

N/A

OTHER REQUIREMENTS

Note:
This is also from HellermannTyton:
Their Part Number is 156-00592



THIS DRAWING IS THE PROPERTY OF ADRIAN STEEL COMPANY AND IS NOT TO BE USED IN ANY MANNER DETRIMENTAL TO THE INTERESTS OF ADRIAN STEEL COMPANY

TOLERANCES & INSPECTION

UNLESS OTHERWISE SPECIFIED

ALL BEND ANGLES ARE 90 DEGREES

ALL DIMENSIONS ARE IN INCHES.

REFERENCE DIMENSIONS (X.XXX)
DO NOT REQUIRE INSPECTION

FEATURES	HOLES/SLOTS	ANGLES
0.0 = ± .125	0.0 = ± .062	0° = ± 2°
0.00 = ± .062	0.00 = ± .031	0.0° = ± 1°
0.000 = ± .031	0.000 = ± .015	

Material Thickness: per ASTM Std.
Weld Callouts per AWS

RELEASE & REVISIONS

INITIAL ECN: **22671**

CURRENT ECN: **22671**

ECN DESCRIPTION:

RELEASE TO PRODUCTION

REVISED BY: **EMS**

PURCHASED COMPONENT

REFERENCED SUPPLIER AND/OR MANUFACTURER

Fastenal

REFERENCED SUPPLIER AND/OR MANUFACTURER PART NUMBER

0787863

COLOR (ONLY LIST IF COLOR SPECIFIC)

COMODITY ITEM (Y/N) (YES = ALL DIMENSIONS AND NOTES ARE REFERENCE)
(NOTE: DIMENSIONS AND FEATURES MAY VARY FOR A COMODITY ITEM.)

NO

PRINTED DOCUMENT IS UNCONTROLLED

Sheet 1 of 1

PART / PRODUCT IDENTIFICATION



ADRIAN STEEL®

ADRIAN STEEL COMPANY
906 JAMES STREET, ADRIAN, MI 49221

REVISION LEVEL

A

MAT'L USED:

DESIGNED BY: **EMS**

DESCRIPTION:

Clip, Black UV Tie, HellermannTyton

WEIGHT (Lbs.): **0.5**

SEGMENT CODE: **ELE**

PART NUMBER: **59713**

<i>INSTR. NUMBER</i> : 67827 <i>PART NUMBER</i> : 67826 <i>PART</i> • MAVERICK INVERTER <i>DESC.</i> • BRACKET	<i>PG:</i> 1	<i>REV:</i> B	<i>ITEM NO.</i> 1	<i>PART NUMBER</i> 67466-B	DESCRIPTION MAVERICK INVERTER BRACKET, BLACK	QTY. 1
			2	BAG67466	FAS BAG MAVERICK INVERTER BRACKET	1
			3	67827	INSTALL INS FOR 67826	1

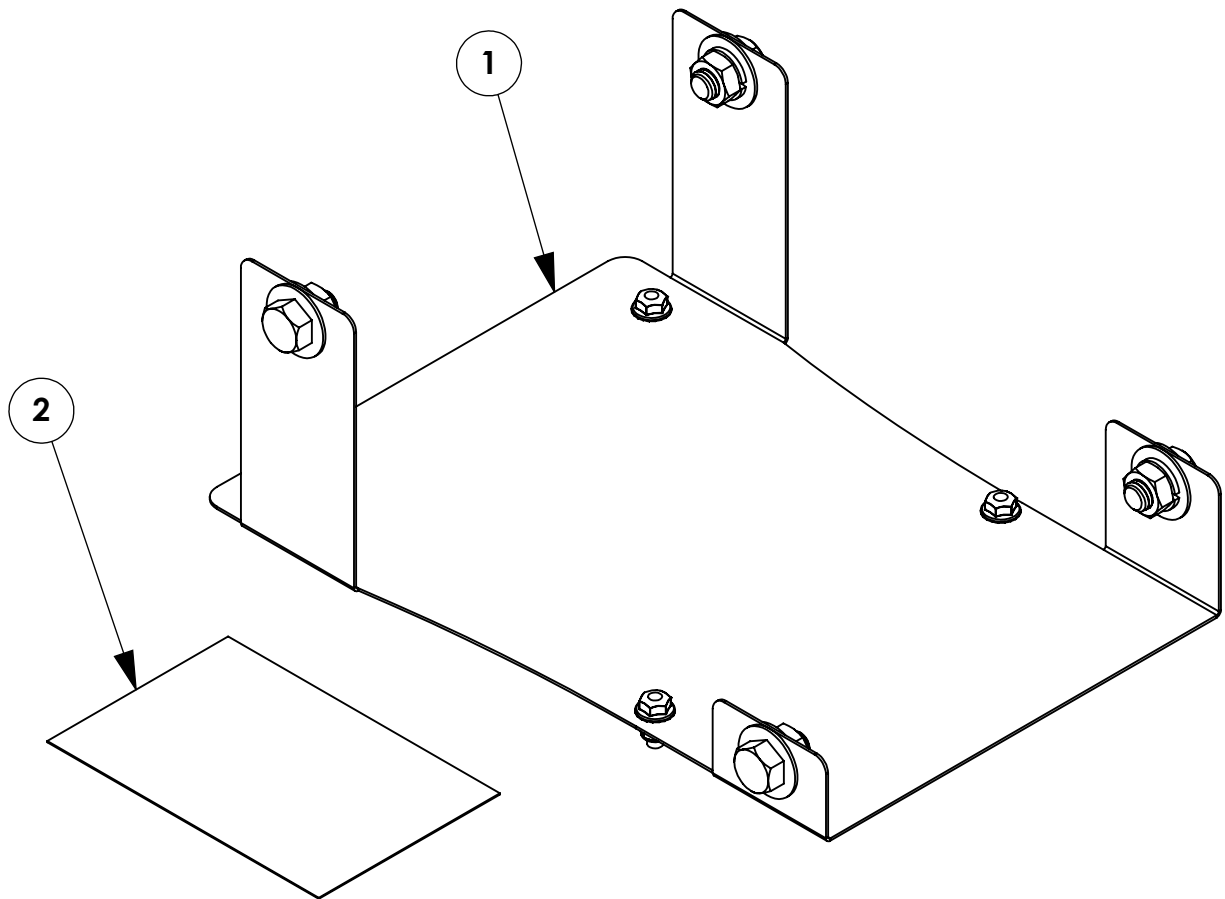

GET TO KNOW THE VEHICLE - AT THE BEGINNING OF ANY INSTALLATION, CHECK THE LOCATION OF THE FUEL TANK, FUEL LINES, BRAKE LINES, HIGH VOLTAGE BATTERIES AND WIRING HARNESSSES TO AVOID INJURY OR PROPERTY DAMAGE FROM TOOL CONTACT.

SEAL ALL EXTERIOR HOLES - ALL INSTALLATION HOLES SHOULD BE SEALED WITH BUTYL TAPE OR SILICON TO PREVENT WATER AND EXHAUST GASES FROM ENTERING THE VEHICLE.

CONTROL DRILL DEPTH - TO AVOID DAMAGE TO THE VEHICLE, USE A DRILL STOP OR CLEARED STEP BIT WHEN DRILLING INSTALLATION HOLES.

ALWAYS ADD PRIMER - WHEN ADDING INSTALLATION HOLES BE SURE TO USE A SELF-ETCHING PRIMER TO PREVENT CORROSION, FASTENER FAILURE AND INJURY.

MOUNTING POINTS MUST HAVE METAL-TO-METAL CONTACT - USE PROVIDED MOUNTING SPACERS TO ACCOMMODATE FOR VEHICLE FEATURES, CARPET OR SUBFLOORS.

PROVIDE CLEARANCE FOR SPACERS - IF THE INSTALLATION VEHICLE CONTAINS A CARPET OR SUBFLOOR, USE A 1-3/16" DIAMETER CARPET CUTTER (P/N: 31183-0) AT ALL MOUNTING LOCATIONS TO OPEN UP ROOM FOR SPACERS.

CHECK SPACER ORIENTATION - BE SURE THAT THE INDENT IN THE SPACER COVERS THE PLUSNUT HEAD; THIS ENSURES THE MOST METAL-TO-METAL CONTACT AND REDUCES VIBRATION.

PLUSNUT INSTALLATION - A PLUSNUT GUN IS RECOMMENDED FOR PLUSNUT INSTALLATION FOR ITS PRODUCTION SPEED. HOWEVER, A PLUSNUT SETTING TOOL CAN ALSO BE USED (P/N: 22200-0).

THRU-BOLT CLEARANCE - WHEN USING A THRU-BOLT AT ANY MOUNTING LOCATION, BE SURE THAT YOUR HOLE HAS 1/16" CLEARANCE.

FASTENERS USED

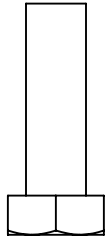

FAS0082
SCREW, HH
5/16-18 X 1
QTY: 4

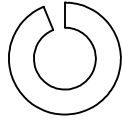

FAS0098
WASHER, LCK SPLIT
5/16 ZP
QTY: 4

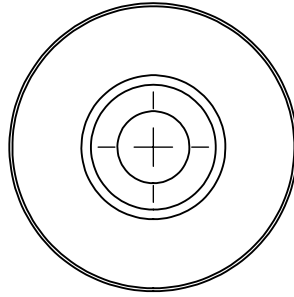

FAS0833
WASHER, CUP
FLANGED 1/2-13 SS
QTY: 8

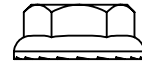

FAS0135
NUT, HEX FLNG
5/16-18 ZN
QTY: 4

BEGIN ASSEMBLY

STEP 1 - MOUNT INVERTER TO BRACKET AS SHOWN

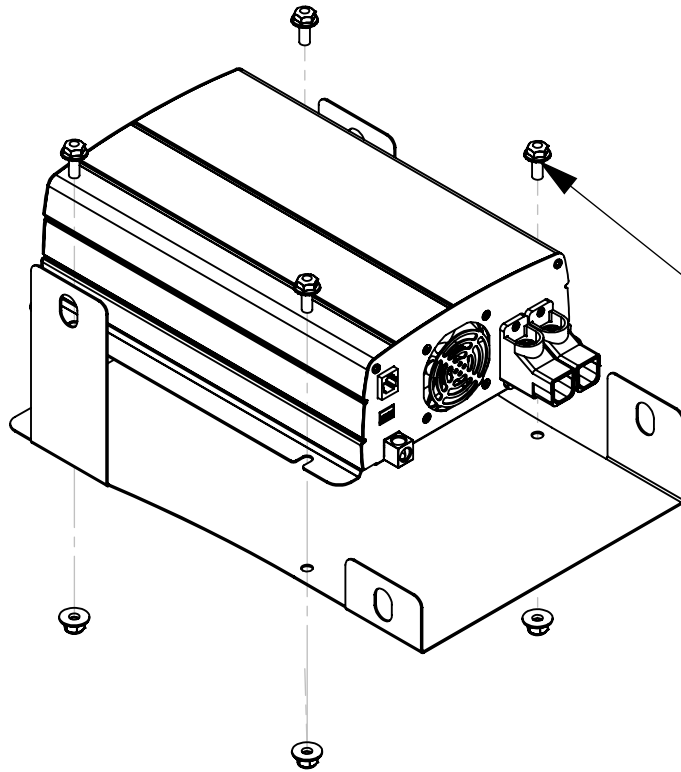

USE FAS0018 AND FAS0055
(4 PLACES)
(COMES WITH INVERTER KIT)
5/16 WRENCH
5/16 SOCKET

STEP 2 - LOOSELY ASSEMBLE THE FASTENERS AS SHOWN

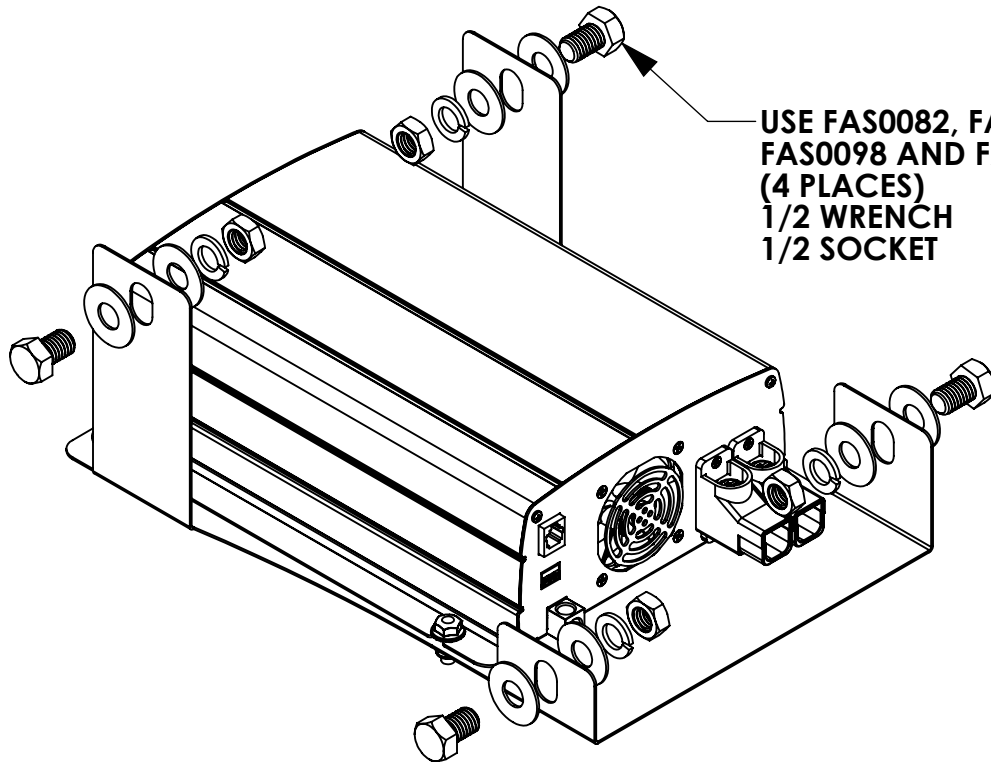

USE FAS0082, FAS0833,
FAS0098 AND FAS0135
(4 PLACES)
1/2 WRENCH
1/2 SOCKET

BEGIN INSTALLATION

STEP 3 - PLACE INVERTER AND MOUNT IN COMPARTMENT BEHIND DRIVERS SEAT. ALIGN BOLT HEADS WITH FACTORY SLOTS. TIGHTEN THE FASTENERS TO SECURE.



PURCHASED COMPONENT KEY FEATURES

DESCRIPTION OF REQUIREMENTS

DIMENSIONAL REQUIREMENTS (AS SHOWN ON DRAWING)

N/A

LOAD/RATING REQUIREMENT

N/A

MATERIAL REQUIREMENT

N/A

PACKAGING REQUIREMENT

N/A

OTHER REQUIREMENTS

Description:
Cable kit for Vanner TS 700/1kW Inverter for Maverick ICE
Not compatible with Maverick Hybrid

Includes:
Inverter Cables - See Supplier Print fo Details

- 1 - 150 AMP MEGA Fuse
- 10 - Cable Ties
- 1 - Bussman Fuse Holder

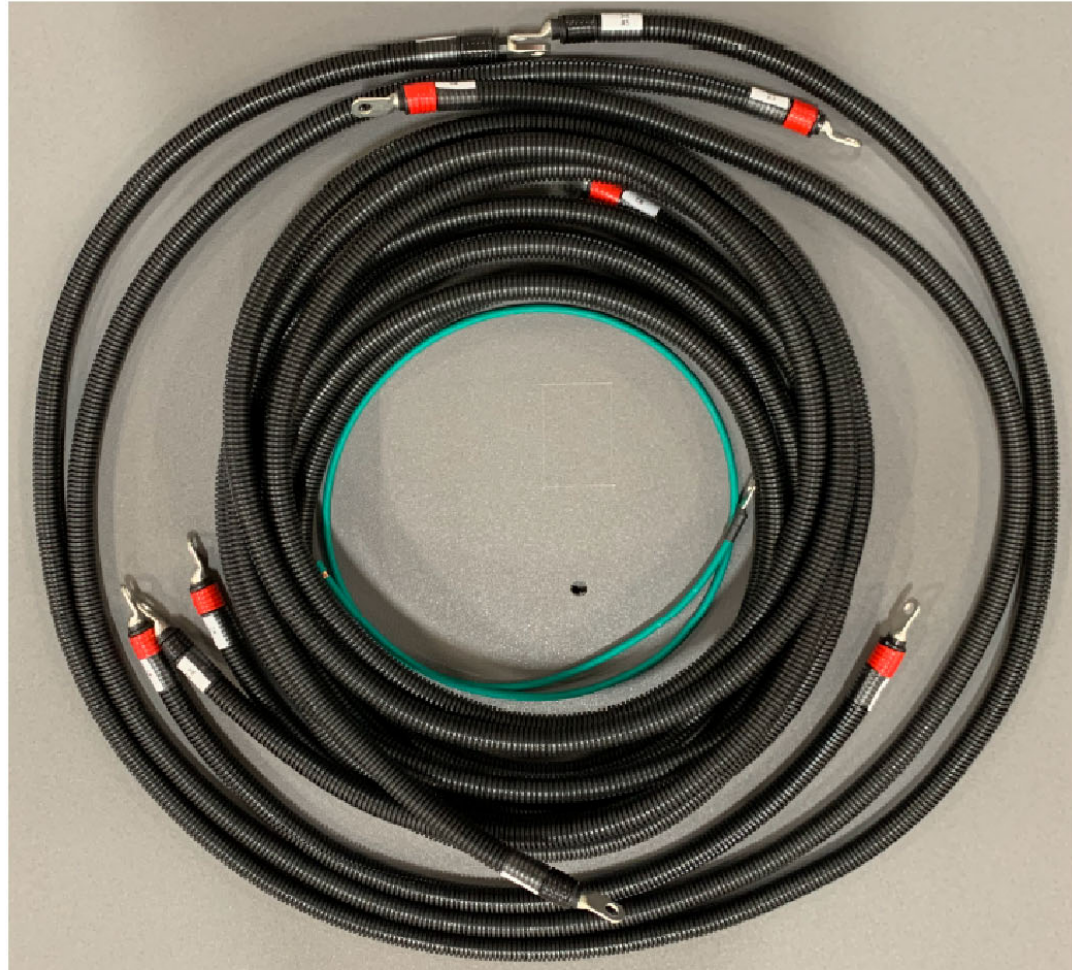

THIS DRAWING IS THE PROPERTY OF ADRIAN STEEL COMPANY AND IS NOT TO BE USED IN ANY MANNER DETRIMENTAL TO THE INTERESTS OF ADRIAN STEEL COMPANY

TOLERANCES & INSPECTION

UNLESS OTHERWISE SPECIFIED

ALL BEND ANGLES ARE 90 DEGREES

ALL DIMENSIONS ARE IN INCHES.

REFERENCE DIMENSIONS (X.XXX)

DO NOT REQUIRE INSPECTION

FEATURES	HOLES/SLOTS	ANGLES
0.0 = ± .125	0.0 = ± .062	0° = ± 2°
0.00 = ± .062	0.00 = ± .031	0.0° = ± 1°
0.000 = ± .031	0.000 = ± .015	

Material Thickness: per ASTM Std.
Weld Callouts per AWS

RELEASE & REVISIONS

INITIAL ECN: **26072**

CURRENT ECN: **26072**

ECN DESCRIPTION:

RELEASE FOR PRODUCTION

REVISED BY: **AJE**

PURCHASED COMPONENT

REFERENCED SUPPLIER AND/OR MANUFACTURER

VANNER

REFERENCED SUPPLIER AND/OR MANUFACTURER PART NUMBER

D020501

COLOR (ONLY LIST IF COLOR SPECIFIC)

COMODITY ITEM (Y/N) (YES = ALL DIMENSIONS AND NOTES ARE REFERENCE)
(NOTE: DIMENSIONS AND FEATURES MAY VARY FOR A COMODITY ITEM.)

NO

PRINTED DOCUMENT IS UNCONTROLLED

Sheet 1 of 1

PART / PRODUCT IDENTIFICATION



ADRIAN STEEL

ADRIAN STEEL COMPANY
906 JAMES STREET, ADRIAN, MI 49221

REVISION LEVEL

A

MAT'L USED: **PURCHASED**

DESIGNED BY: **AJE**

DESCRIPTION: **KIT CBL, 700W/1KW NO AUX MAVERICK-ICE**

WEIGHT (Lbs.):

10

SEGMENT CODE: **EIN**

PART NUMBER: **69834**

ITEMS IN BAG: 03199
 QTY 1, #012992 FUSE HOLDER QTY 1, #D020505 TIMER KIT
 QTY 1, #010098 150A FUSE
 QTY 10, #013131 CABLE TY

REVISIONS			
REV	DESCRIPTION	DATE	REA/ECO

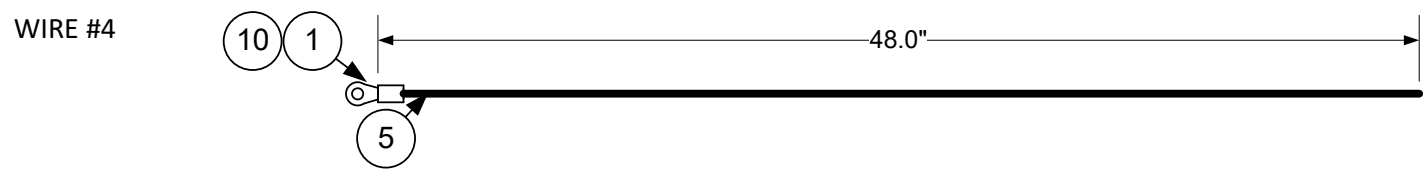
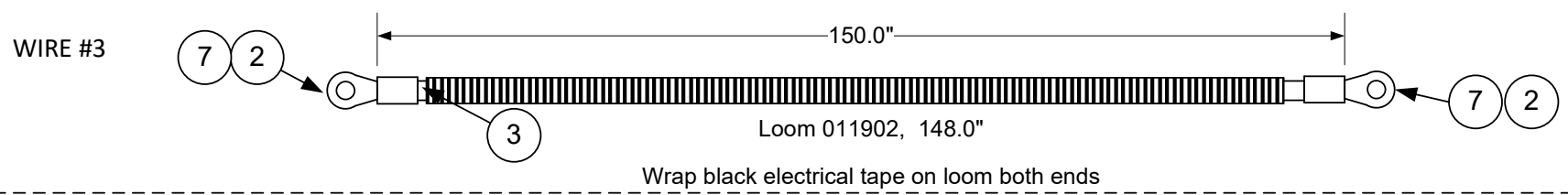
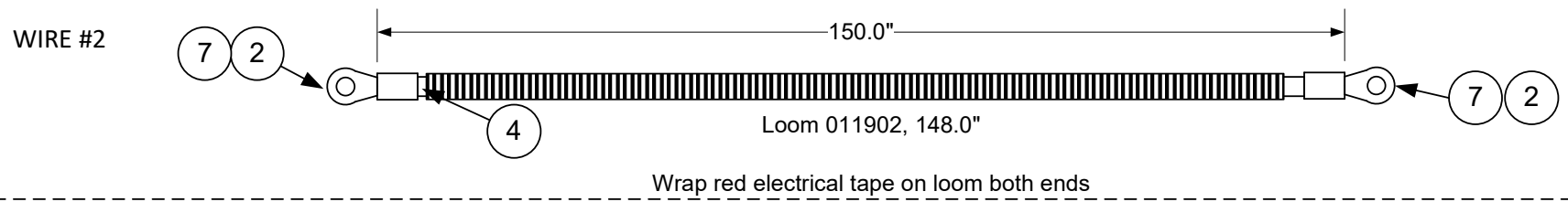
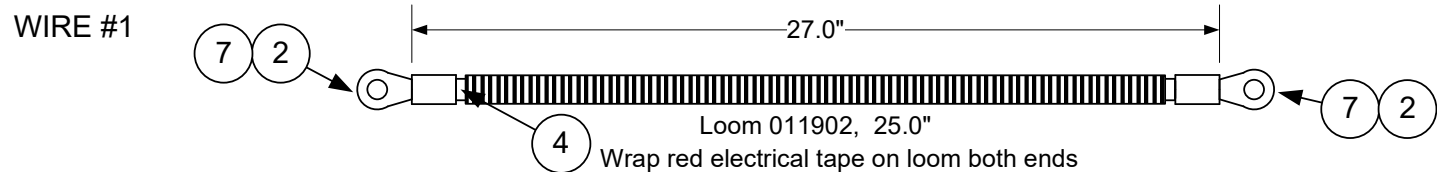

Notes:
 Each cable to have wire number as listed marked on both ends of wires, exterior of loom behind tape, harness suppliers discretion on materials used

SCALE: NONE	REA/ECO NO.: 5268	TOL. UNLESS OTHERWISE NOTED .x ± .025 .xx ± .015 .xxx ± .005	HILLIARD, OHIO USA
THIS DRAWING AND ALL INFORMATION CONTAINED HEREIN IS THE PROPERTY OF VANNER INC. AND MAY NOT BE COPIED, REPRODUCED OR DIVULGED TO UNAUTHORIZED PERSONS WITHOUT THE EXPRESS WRITTEN CONSENT OF VANNER INC. IT IS PROVIDED SOLELY FOR THE CONVENIENCE OF THE USER AND SHALL BE RETURNED UPON REQUEST.		DRN/DATE MEO 2/2/2022	
		TITLE: DWG, HRNS, TS 700/1000, 12.5, TVM, MAVERICK ICE	
		DRAWING/PART NO. D920501	SHEET 1 OF 2 REV A

This page for Adrian Steel
ONLY

REVISIONS			
REV	DESCRIPTION	DATE	REA/ ECO

Part Number	Description	Quantity	Balloon
D020501	HRNS, TS 700/1000, 12.5, TVM, MAVERICK ICE	0	5268
010098	FUSE, 150 AMP, BOLT TYPE, MEGA/AMG	1	
011902	LOOM, 1/2" I.D., NYLON, BLACK, HI-TEMP, SPLIT	26.75	
012573	HEATSHRINK, ADHESIVE, .375 ID, BLK	0.08	1
012575	HEATSHRINK, ADHESIVE, .75 ID, BLK	0.5	2
012992	FUSEHOLDER, BUSSMANN, AMG 100-300 AMPS	1	
013131	CABLE TY 6/6 NYLON 9.625"L X 0.145" W, BLACK, 40LB	10	
013942	WIRE, 2 AWG, SGX, SAE J1127, BLACK	12.5	3
013943	WIRE, 2 AWG, SGX, SAE J1127, RED	14.75	4
013944	WIRE, 8 AWG, GXL, SAE J1128, DARK GREEN	4	5
015481	LUG, 2 AWG, RING TONGUE, SEALED, 5/16 STUD	6	7
015696	BOX, SHIPPING, 16 X 16 X 6	1	
016444	TAPE VINYL PLASTIC ELECTRICAL, RED	0	
02424	TAPE VINYL PLASTIC ELECTRICAL, BLACK	0	
10705	TERMINAL RING TONGUE 8AWG 5/16STUD	1	10
03199	BAG ZIPLOCK 9X12 4MIL	1	
D020502	LABEL, SPEC, D020501	0	
D020505	HARNESS, ASSM, TVM, SWITCH, MAVERICK	1	
D08320	LABEL 3.00"X4.00" SILVER (BLANK)	1	
D920501	DWG, HRNS, TS 700/1000, 12.5, TVM, MAVERICK ICE	0	

SCALE: NONE

REA/ECO NO.: 5268

TOL. UNLESS
OTHERWISE NOTED

.x ± .025

.xx ± .015

.xxx ± .005

VANNER
INCORPORATED

HILLIARD, OHIO USA

THIS DRAWING AND ALL INFORMATION CONTAINED HEREIN IS THE PROPERTY OF VANNER INC. AND MAY NOT BE COPIED, REPRODUCED OR DIVULGED TO UNAUTHORIZED PERSONS WITHOUT THE EXPRESS WRITTEN CONSENT OF VANNER INC. IT IS PROVIDED SOLELY FOR THE CONVENIENCE OF THE USER AND SHALL BE RETURNED UPON REQUEST.

DRN/DATE
MEO
2/2/2022

CHK/DATE

TITLE: DWG, HRNS, TS 700/1000, 12.5,
TVM, MAVERICK ICE

DRAWING/
PART NO. D920501

SHEET
2 OF 2

REV
A