

Introduction / Comments:

Install Instructions For Exterior Plug & Play Lights For Silverado HD

Note:

Read all instructions prior to installation. Review the Adrian Steel **GENERAL PRECAUTIONS PAGES (56638)** before attempting installation. Only personnel familiar with using electrical best practices should perform this install. Reference **ELECTRICAL BEST PRACTICES MANUAL (54479)** before attempting installation.



Installation Instructions For Exterior Plug And Play Lights For Silverado Heavy Duty

Table of Contents:

Torque requirements.....2

Introduction Statement.....3

Overall Harness Diagram.....3

Tools needed.....3

Harnesses/Components Needed (If Applicable).....4

Component Placements.....5

Overall Harness Routing.....6-7

Beginning Install.....8

Strobe Installation Instructions.....11

Beacon/Lightbar Installation Instructions.....17

*****TORQUE*****
Torque all strobe fasteners to 10 in-lbs.
DO NOT OVER TIGHTEN

DO NOT MOUNT ON A CURVED SURFACE

****Please read statement below before moving forward****

Before installation, disconnect the OEM negative battery cable.

These plug and play kits are completely modular and can be configured in many different ways. Placement of lights will be determined by sales order drawings/customer ask. Therefore, these instructions are for the most standard configurations, and for reference only.

Please reference the order drawing and spec sheet to see what components are going to be installed on this particular upfit.

These installation instructions are for most cases and for reference. Not all installs will have strobes, beacons, and lightbars. Reference the instructions for only what you are installing.

Overall Harness Diagram

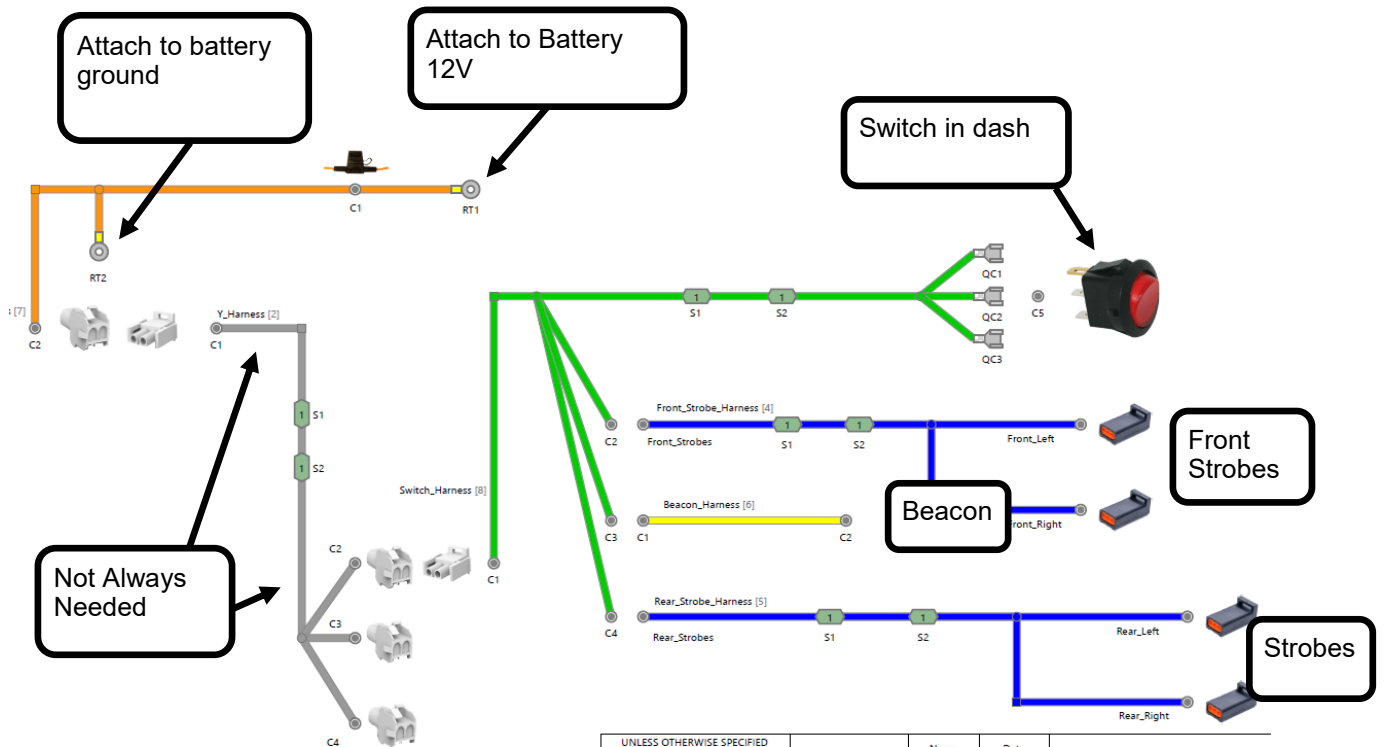

Tools required:

13 socket and 20 torx bit

Phillips bit and 5/16" step drill bit

Power drill and impact

Torque wrench

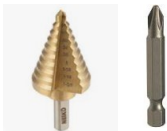

Components

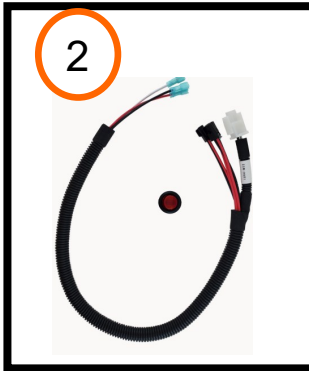
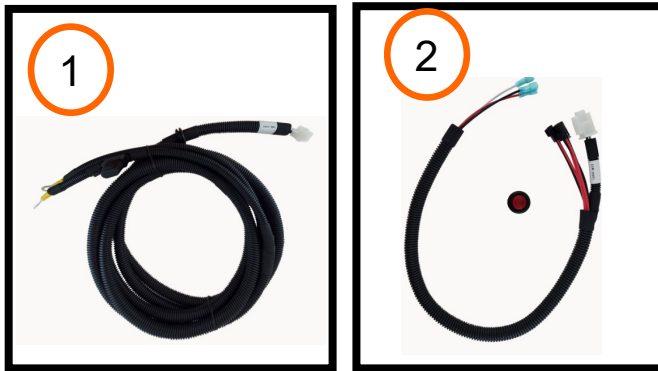

	Part Number	Description
1	67095	Power Harness #4
2	67097	Switch Harness #1
3	67103	Front Strobe Harness #3 (If Applicable)
4	67107	Rear Strobe Harness #2 (If Applicable)
5	67112	Beacon/Lightbar Harness #2 (If Applicable)
6	67686 or 67687	Strobes (If Applicable)
7	67689 or 67690	Beacons (If Applicable)
8	69468 or 70266	Beacon/Lightbar Mount (If Applicable)
9	67691 or 67692 or 96118 or 67693	Lightbars (If Applicable)



The purpose of plug and play lighting is to be completely modular. Due to this feature, refer to the order drawing for all exact lighting placements. These installation instructions are for most cases and for reference. Not all installs will have strobes, beacons, and lightbars. Reference the instructions for only what you are installing.

Harness pictures are for reference only.

Placements

Switch placement: Dash panel under headlight buttons

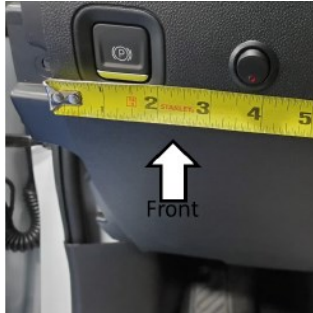

** (Button orientation depends on if there are OEM AUX switches) **



Front Strobes: Grill



** (Grill orientation depends on vehicle trim level) **

*****TORQUE STROBES TO 10-IN-LB'S MAXIMUM*****

Beacon or Lightbar: On CHMSL above 3rd brake light—on some sort of mount

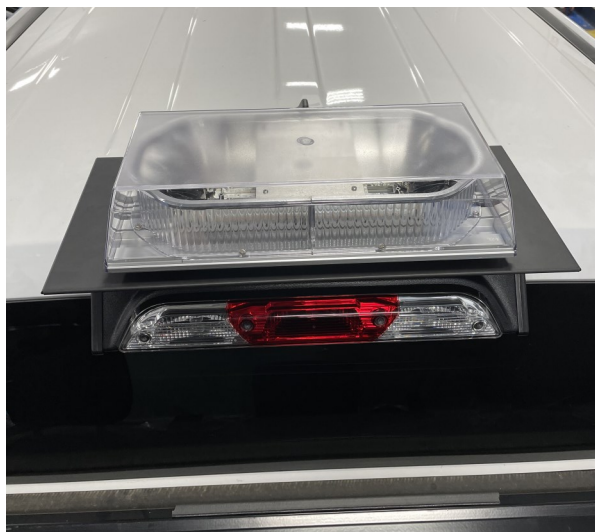

Rear Strobes: Rear Bumper



Routing Overview

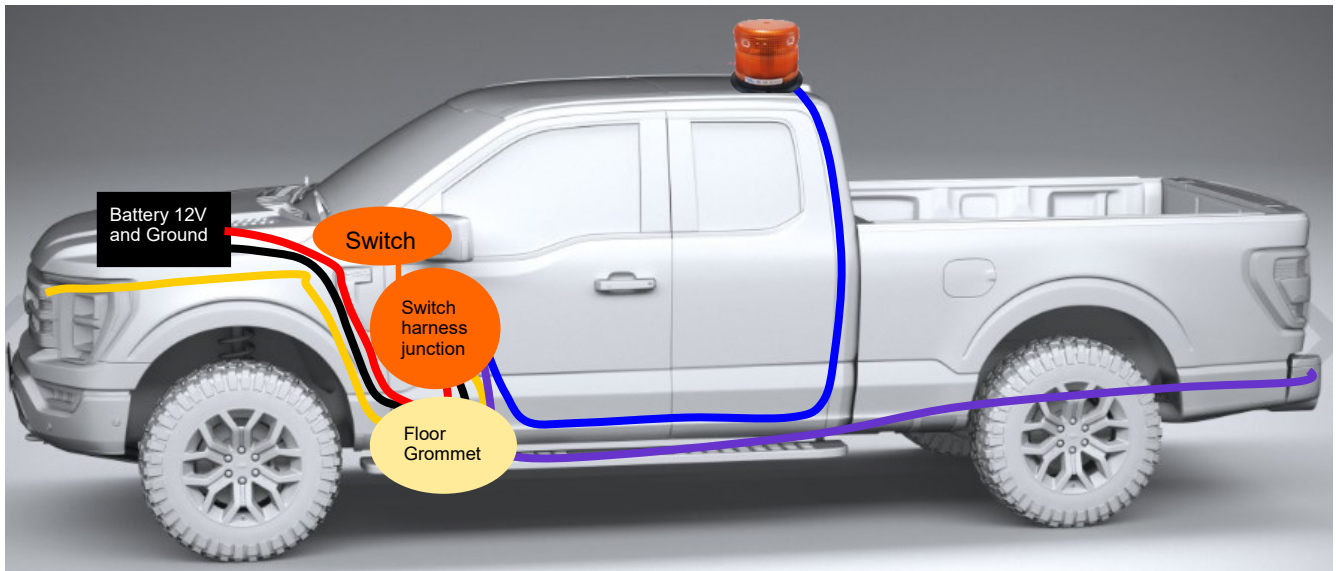
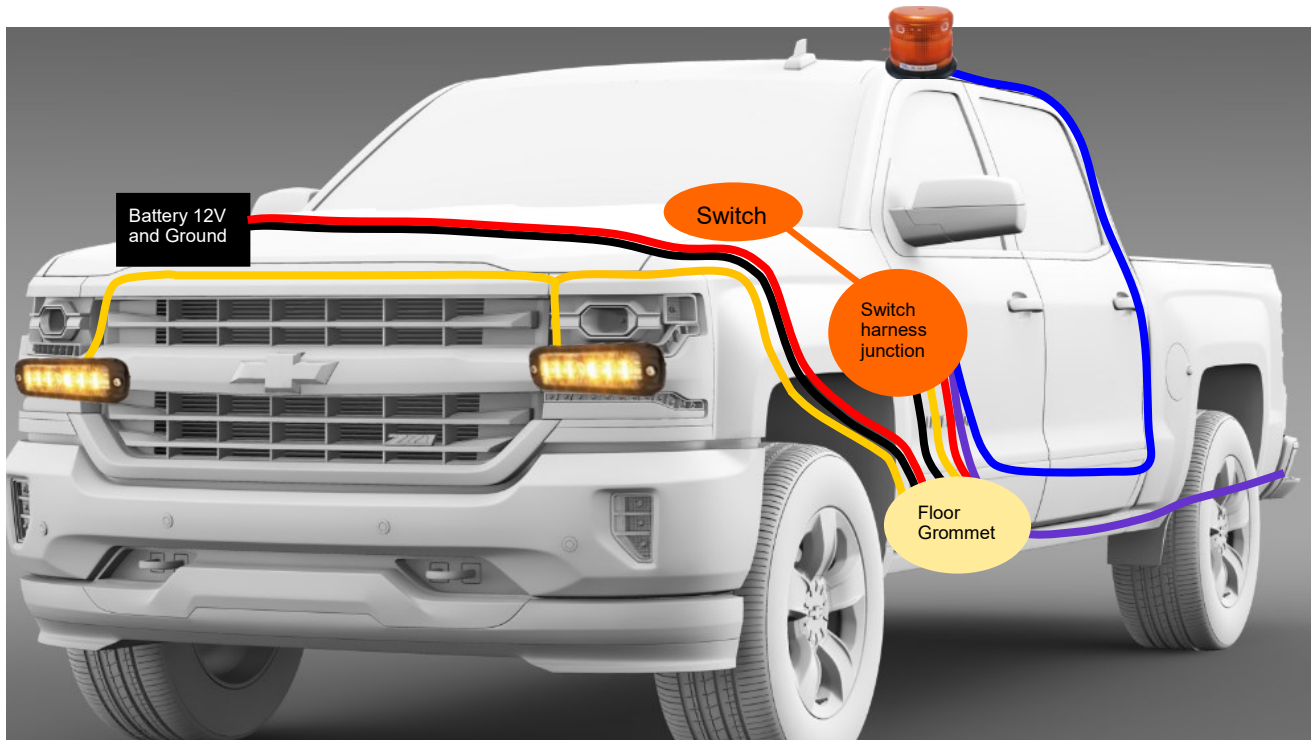

Color	Key - Items
Yellow	Strobes - Front strobe harness
Red/Black	Power harness: Battery to kick panel
Orange	Switch harness: Switch in dash
Blue	Lightbar harness: Switch to lightbar
Purple	Strobes - Rear strobe harness



Overview of Routing-Beacon/Lightbar Wire Harness:

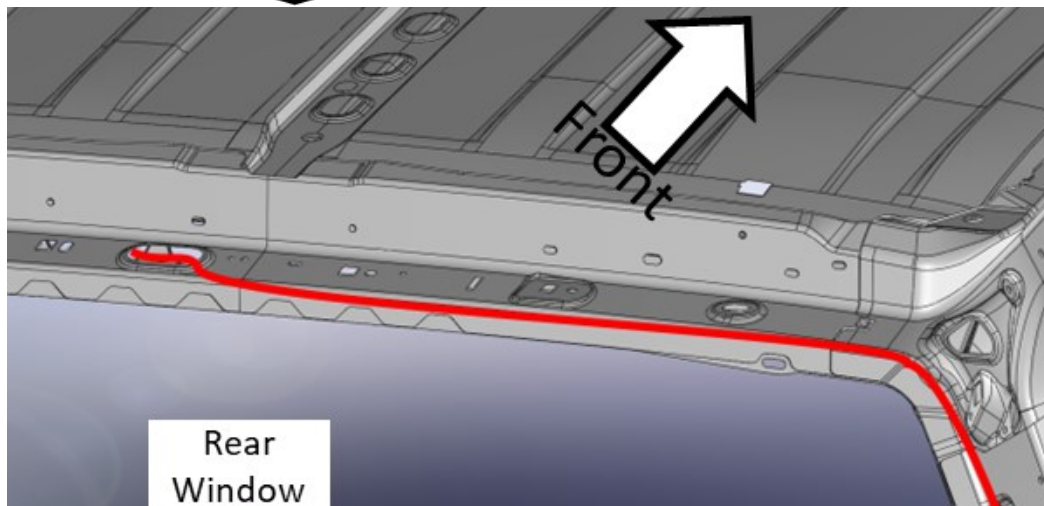
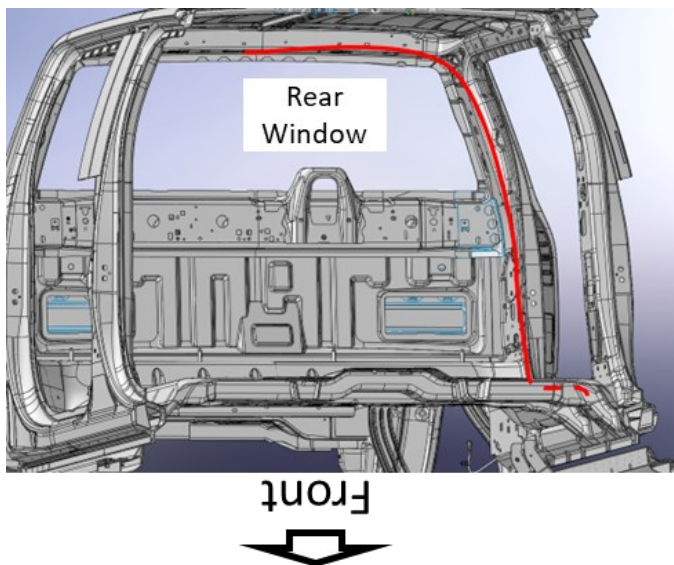
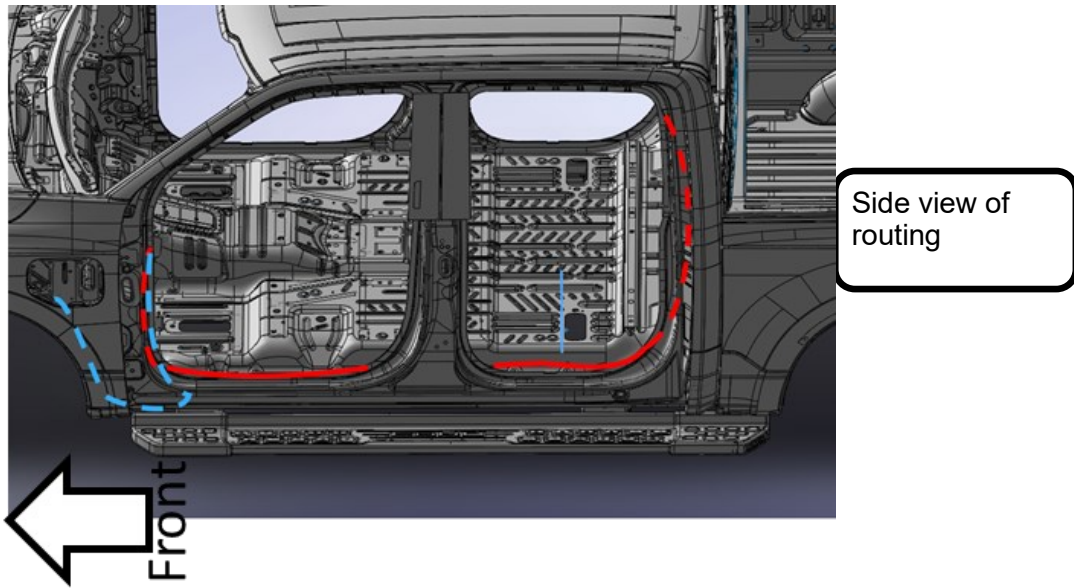

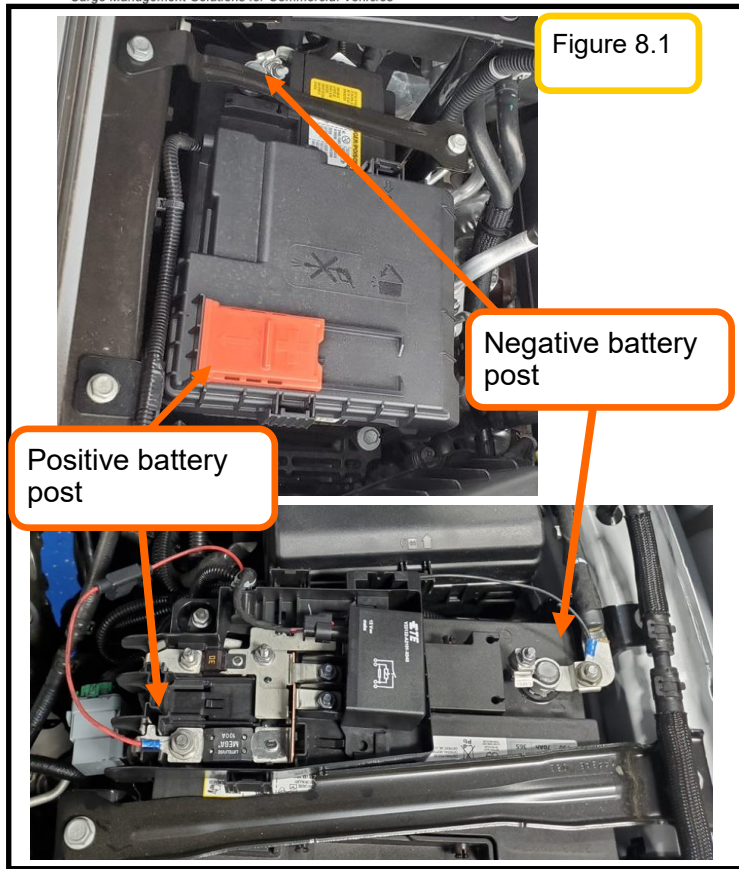

Figure 8.1

Step 1: Locate the power harness #67095.

Remove the fuse from the inline fuse holder until the end of the install
Locate the OEM battery under the hood.

Step 2: Remove the cover and attach the red wire with the ring terminal to the battery positive post.

Attach the black wire with the ring terminal to the battery negative post.
Figure 8.1.

Route the white connector end along the underside of the cab filter (see figure 8.2 red dotted line) to the firewall. Use edge-biters and zip ties to secure the wiring

Step 3: Locate the floor grommet in the cab, by the driver's foot well area. You will need to remove the trim and some carpet in order to see this. The grommet is circled in red.
Figure 8.3 and 8.4.

Drill a 3/4" hole (to fit the grommet in the kit—Part number 35735-0) in the OEM floor grommet.

****BE SURE TO CHECK THAT THE OPPOSING SIDE OF THE GROMMET IS CLEAR BEFORE DRILLING.****

Insert the grommet into the hole. Route the white connector end through the grommet (white connector end will be placed in the cab side) .

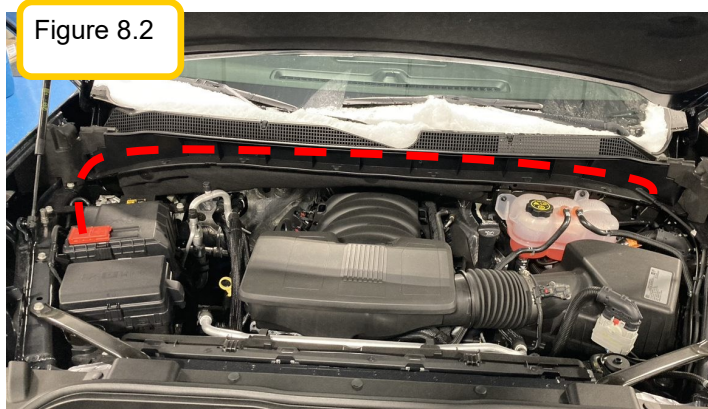

Figure 8.2



Figure 8.3

Trim to remove

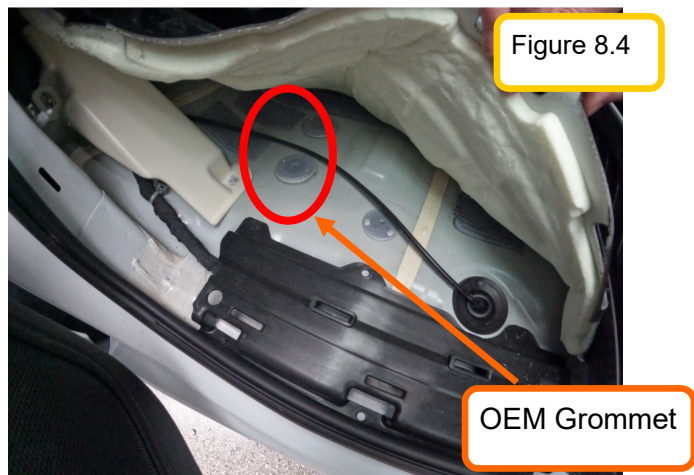

Figure 8.4

OEM Grommet

Power harness

Switch Harness



Step 4: Locate the switch harness #67097

Connect the switch harness connector to the power harness in the kick panel area.

****Try to disassemble the IP trim and remove the front kick panel. If it is easy, the vehicle has a standard trim level. If the panel doesn't remove easily, the vehicle has a heavy duty trim level. Based on trim level, follow the corresponding process below****

Figure 9.1

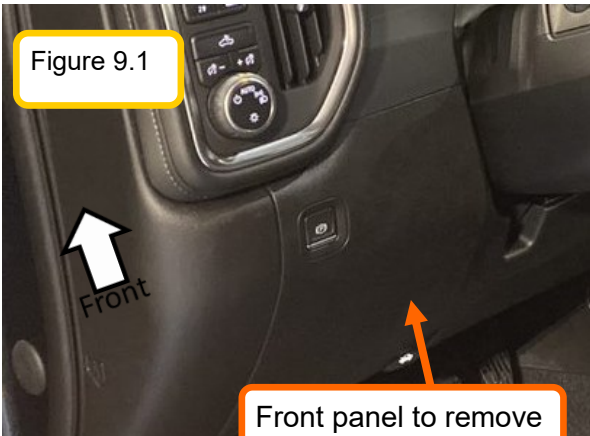

Standard Trim Level

****If you accurately place the switch to the measurements below, you may NOT need to take off the panels. Verify hole locations before drilling** Skip to Step 6 if you do not take the panel off.**

Disassemble the IP trim to gain access behind the dash. Figure 9.1 and 9.2.

Route the switch end of the switch harness up the dash and through the opening in the IP. Figure 9.2.

**Note the picture shows two switches, there will only be one for this install.*

Secure to the OEM harnesses behind the IP.

Behind the headlight trim panel

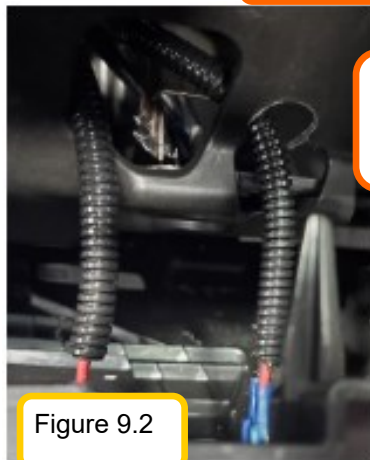

Step 5A: Drill a hole for the switch, in the trim panel like shown in the pictures to the left:

- If there are no OEM AUX Switches: The hole will be 3.75" from the edge of the trim panel and centered with the parking button. Figure 9.3.

- If there are OEM AUX Switches: The hole will be centered with the "AUX 3" button. The hole will be equidistant between the AUX switches and the top lip of the panel. Figure 9.4.

Figure 9.2

Route the harnesses through the hole

Front



Figure 9.3

Figure 9.4

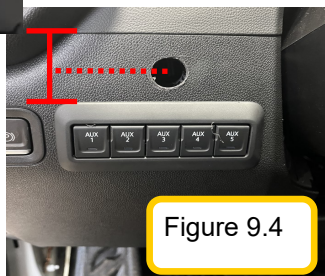

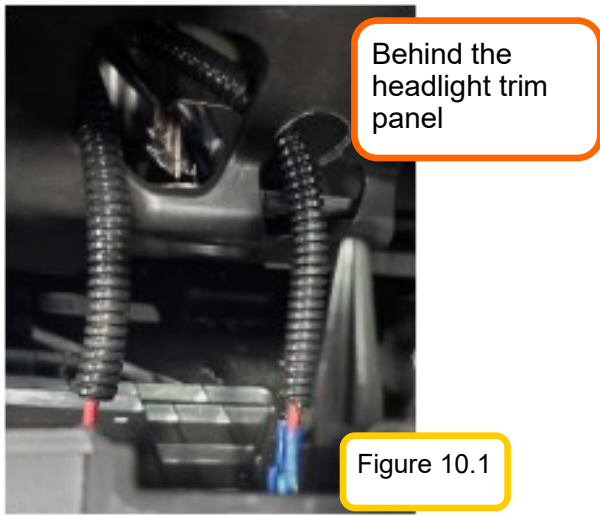

Figure 10.1

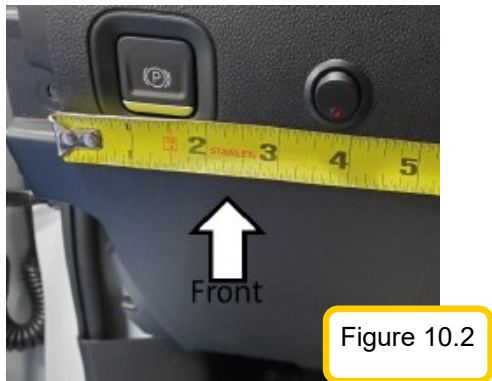

Figure 10.2

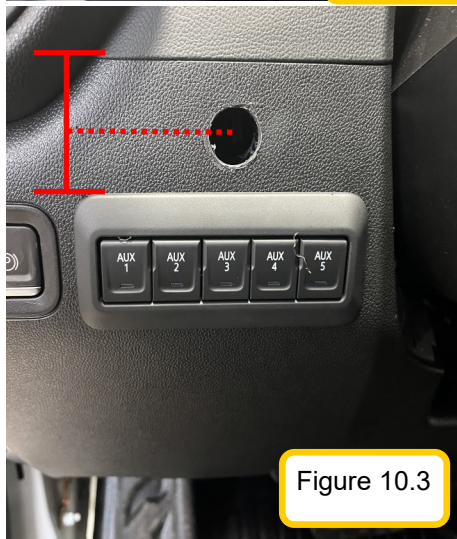

Figure 10.3



Figure 10.4

Heavy Duty Trim Level

While the kick panel cannot be removed easily, you can reach your hand up into the cavity where the switch will be mounted.

Route the switch end of the switch harness up the dash and through the opening in the IP. Figure 10.1.

**Note the picture shows two switches, there will only be one for this install.*

Secure to the OEM harnesses behind the IP.

Step 5B: *Make note that there is a thick sheet that makes wiring impossible after a certain length past the parking button (to the right of AUX 3 in Figure 10.3).*

Drill a hole for the switch, in the trim panel like shown in the pictures to the left:

- If there are no OEM AUX Switches: The hole will be 3.75" from the edge of the trim panel and centered with the parking button. Figure 10.2.

- If there are OEM AUX Switches: The hole will be centered with the "AUX 3" button. The hole will be about equidistant between the AUX switches and the top lip of the panel. Figure 10.3.

Route the harnesses through the hole
=====

Step 6: Reference Figure 10.4 for switch pin outs. Connect the ground spade to the gold pin on the rocker switch

Connect the white battery power spade to the opposite terminal on the switch.
Connect the red spade to the middle pin

Insert the switch into the hole and place the strobe/beacon decal (if supplied) around the switch.

Reassemble all trim and secure wiring.
Place the decal over the switch—if applicable.

Strobe Install—If Applicable

Strobe pictures are for reference only. Please refer to product structure/spec sheets for the actual strobes for the install.



Inside vehicle connector—switch harness



Outside strobe connector

Figure 11.1



Step 1:

Locate the rear strobe harness #67107.

Connect the rear strobe harness to the switch harness (one of the remaining unused connectors) in the driver's foot well. Figure 11.1.

Now locate the front strobe harness #67103. Connect the strobe harness to the switch harness like in the previous step.

Step 2: Route both the harnesses down through the grommet, to the underside of the vehicle body. Figure 11.2. **Silicone the grommet when done.**

Figure 11.2



Step 3: Grab the rear strobe harness, we will route the front strobe harness next.

(Refer to routing diagrams at the beginning of the instructions)

Route the strobe harness rearward following the frame (red dotted line). Secure with zip ties to the OEM harness. Figure 11.3 and 11.4.

Figure 11.3



Figure 11.4



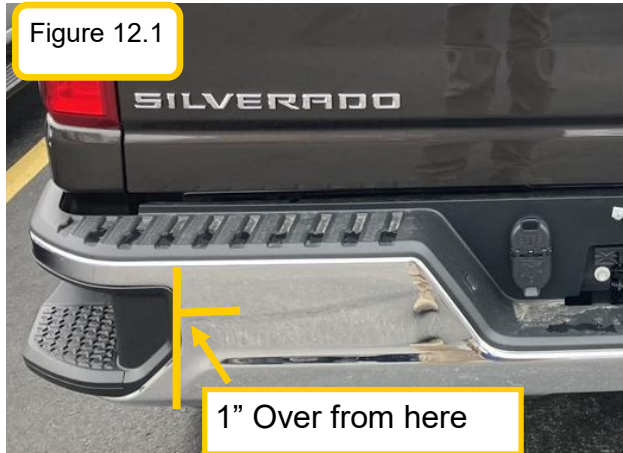

Step 4: Mounting Strobes

Locate the left edge of the rear bumper.

Place the strobe 1" right of the bumper trim, centered vertically on the bumper. Figure 12.1.

If there are reverse sensors, measure 1" over from the reverse sensor and 1" up (or also 1" down from the bumper step). Figure 12.2 and 12.3.

Use the strobe as a template, mark the center hole location on the bumper (for routing the wires through).

Drill a 3/8" hole for the wire pass through of the strobe. Use primer on the hole to prevent rusting.

Connect the strobe light to the harness and silicone the hole.

Place the strobes in their desired locations and fasten them onto the bumper with the **ASCO SUPPLIED SCREW AND NUT: FAS0501 and FAS0503 (for rear bumper only—front will use Ecco/Strobe supplied screws)**

*****TORQUE STROBES TO 10-IN-LB'S MAXIMUM*****

Repeat for the right side strobe.

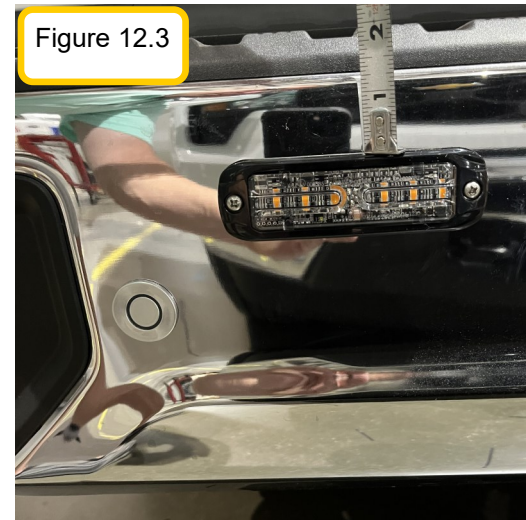
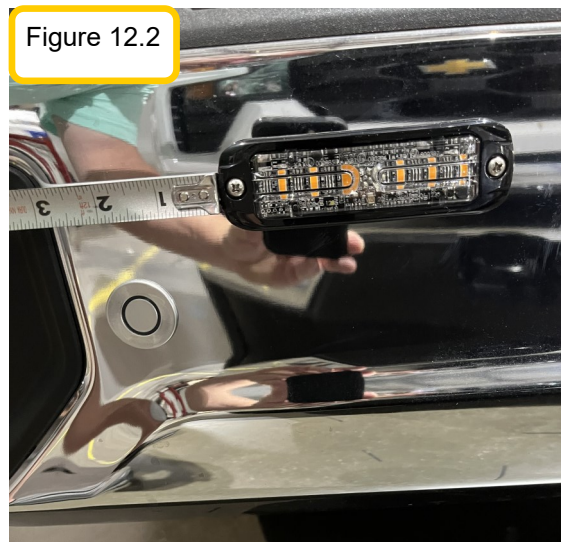

Final Strobe Picture





Figure 13.3

Step 5A: Mounting Front Strobes



Figure 13.1

Measure 9" from this edge

****OBSERVE THE FRONT GRILL OF YOUR VEHICLE. IF THE SAME AS PICTURED IN Figure 13.3 (Standard Trim Level), FOLLOW THIS INSTRUCTION****

Locate the driver's side front headlight.

Measure 9" over from the edge of the plastic trim (Tape touching the metal edge of the grill) under the headlight. See figure 13.1 for measure reference.

Place the edge of the strobe at the 9" mark and about 1/2" down from the bend on the trim. Figure 13.1 and 13.2.

Use the strobe as a template, mark the center hole location on the panel (for routing the wires through). Be sure there is room behind the plastic trim to route the wires through. You do not want to drill a hole into the headlight housing area. If you have to adjust your strobe left or right, please do so.



Figure 13.2

During this install be very careful not to damage the grill - do not bend or flex the grill.

Be sure the strobe will not be placed on a curved surface.

Drill a 3/8" hole for the wire pass through on the strobe.

Do not fasten down the strobes yet. You will do this after the harness is installed.

See figure 13.3. for final placement reference.

Figure 14.1



Step 6A: Locate the front strobe harness #67103 that was already routed through the floor grommet.

Route the harness up into the engine compartment, towards the grill. Continue routing across the front of the frame and over to the passenger's side strobe.

Secure with zip ties to the OEM harness and the holes in the metal.

Figure 14.1 and 14.2. (Red dashed line)

Connect 1 of the strobe harnesses ends to the passenger's side strobe (through the hole in the grill). Then connect the other end to the strobe harness. Figure 14.3.

Do the same with the driver's side strobe now.

Secure wiring with zip ties.

*****TORQUE STROBES TO 10-IN-LB'S MAXIMUM*****

Figure 14.2

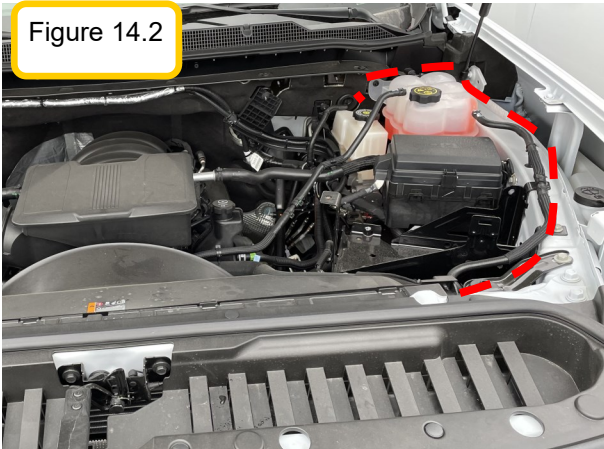
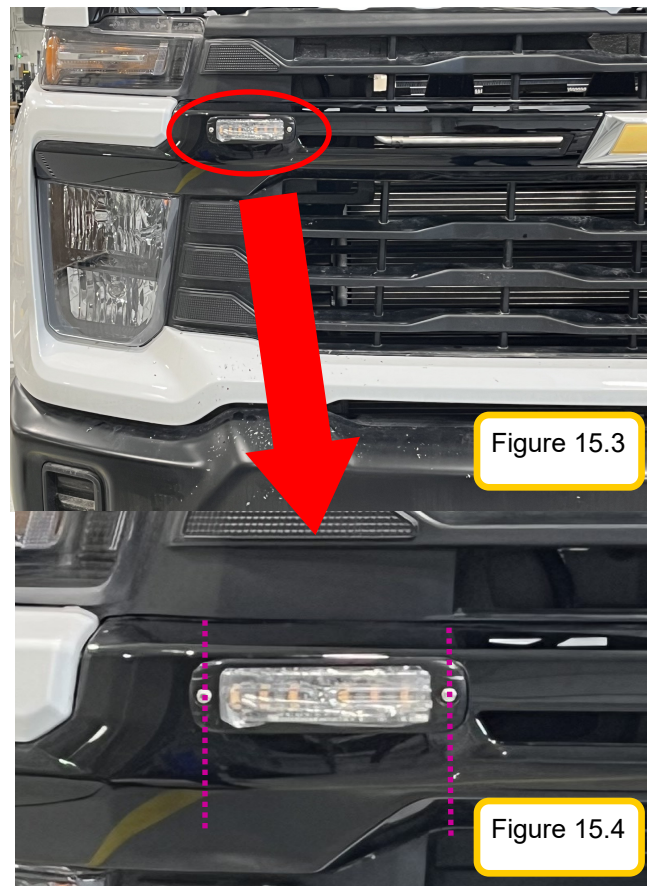

Figure 14.3





Step 5B: Mounting Front Strobes

****OBSERVE THE FRONT GRILL OF YOUR VEHICLE. IF THE SAME AS PICTURED IN Figure 15.2 (Heavy Duty Trim Level), FOLLOW THIS INSTRUCTION****

Locate the driver's side front headlight.

For visual, orient a strobe on left or right side of metal bar with the Chevy logo as shown to the left.

Hold up the strobe so that the mounting screws are in line with the ones shown in Figure 15.4. The left mount is about in line with the bottom of the dark grey trim line above the strobe, and the right mount is about in line with the right-sided end of that same dark grey trim.

Using the strobe as a template, mark the center hole location on the panel (for routing the wires through). Be sure there is room behind the plastic trim to route the wires through (even though in this case, that space will be very small). You do not want to drill a hole into the headlight housing area. If you have to adjust your strobe left or right, please do so.

During this install be very careful not to damage the grill - do not bend or flex the grill.

Be sure the strobe will not be placed on a curved surface.

Drill a 3/8" hole for the wire pass through on the strobe.

Do not fasten down the strobes yet. You will do this after the harness is installed.

See Figure 15.2 for final placement reference.

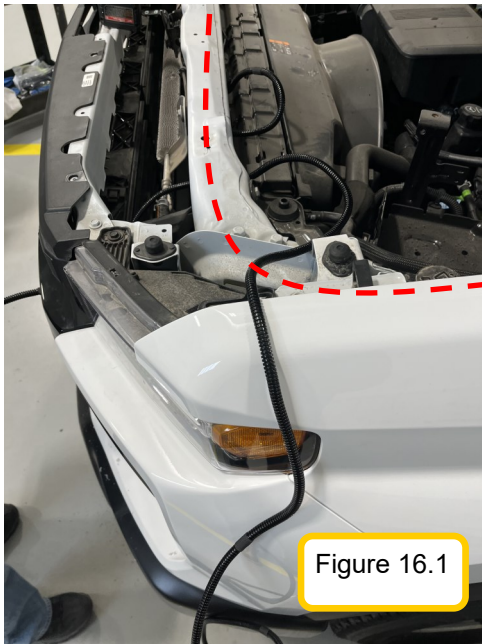

Step 6B: Locate the front strobe harness #67103 that was already routed through the floor grommet.

Route the harness up into the engine compartment, towards the grill. Continue routing across the backside of the radiator crossbeam and over to the passenger's side strobe. Figure 16.1

On the passenger side, route around the air intake column to reach the spot for the strobe.

Secure with zip ties to the OEM harness and the holes in the metal. Figure 16.1 and 16.2. (Red dashed line)

****There are two thin walls to drill holes through in order to power the strobe lights. If possible, drill the inside hole bigger than the outside one (where the strobe wiring connects). Then when connecting the strobe harness to the strobes, it will require a 90 degree turn to fit the connectors through the hole on the cab-side and to the strobe. It is an extremely tight squeeze, so the wider inside hole will be helpful.**

Connect 1 of the strobe harnesses ends to the passenger's side strobe (through the hole in the grill). Then connect the other end to the strobe harness. Figure 13.3.

Do the same with the driver's side strobe now.

Secure wiring with zip ties.

*****TORQUE STROBES TO 10-IN-LB'S MAXIMUM*****



Beacon/Lightbar Install—If Applicable

Lightbar/ beacon/ and mount pictures are for reference only. Please refer to product structure/ spec sheets for the actual beacon/lightbar/mount for the install.

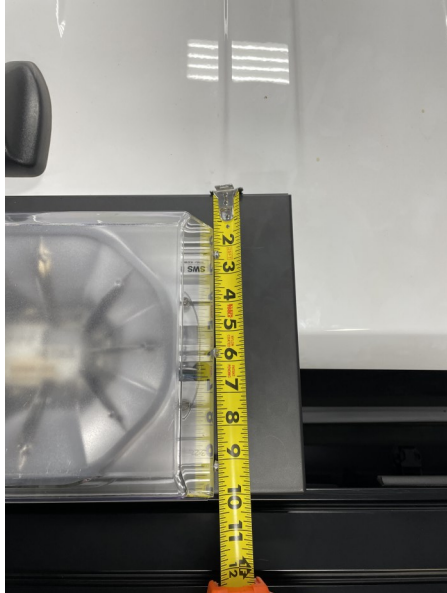

Step 1: On a table/bench: Assemble the light

Assemble the lightbar or beacon to the mount, using the supplied fasteners and rubber spacers with the lightbar.

If installing a Whelen lightbar, use the provided screws (FAS0869), washers (FAS0871), and nuts (FAS0501) in the ASCO kit. They are not provided with the light.

All other lights will have their own hardware.

Note: Lightbar (SWS Apollo) in pictures is for reference only.

Center the lightbar or beacon onto the mount, side to side, then slide the lightbar to the rear of the mount until it is flush. See pictures for reference.

Use the lightbar/beacon as template, mark the needed holes for mounting. Drill the needed holes for mounting.

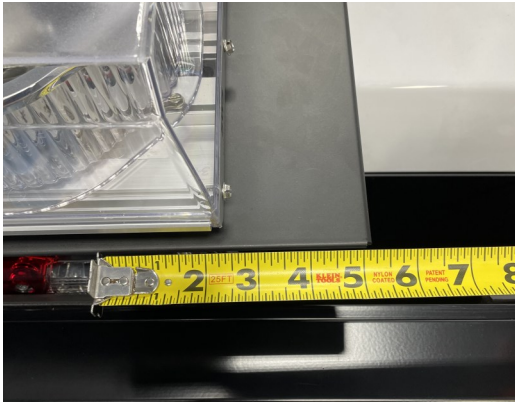

Drill the hole for the wiring pass through and insert the provided grommet (if applicable). **If there is a connector on the end of the lightbar/beacon, use the 1" grommet (36096-0). If there is not a connector, use the 3/8" grommet (70805) and refer to the next page.**

Silicone the grommet/pass thru wiring.

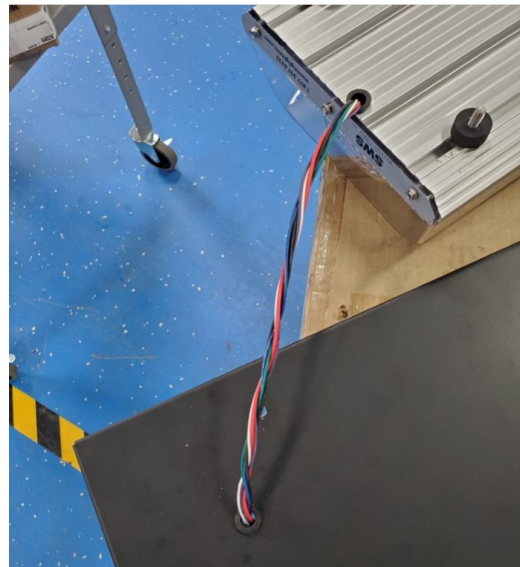
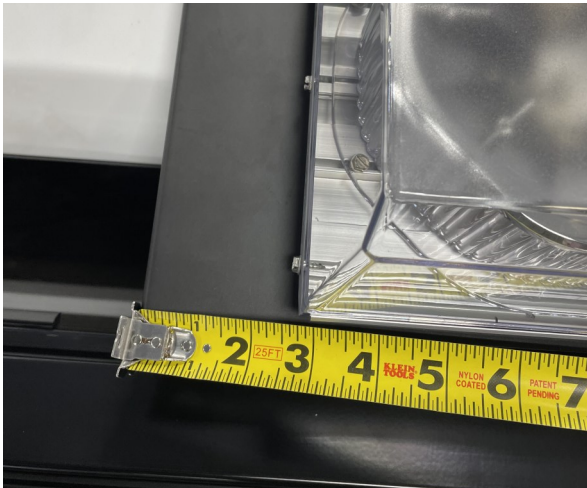

If Lightbar/Beacon does not have a connector on the wires:

Figure 18.1



Figure 18.2



After mounting the light to the Acari mount and pulling the wire through the grommet (70805)

Locate the connector housing inside the lightbar/beacon box. Figure 18.1.

Note if it has a red insert inside the connector or not. Refer to figure 18.2 for red insert inside the connector.

Insert the lightbar wire terminals into the connector. **See steps below:**

In these steps be very careful to place the terminals into the correct side of the connector.

Line the red wire terminal up with cavity #1 and the black wire terminal up with cavity #2. Figure 18.3.

Note the connector has a "1" and a "2" noted on the connector (circled in red). Figure 18.4. The red wire will be inserted into the #1 cavity of the connector. The black wire will be inserted into the #2 cavity on the connector.

Figure 18.3



Figure 18.4



Figure 18.5

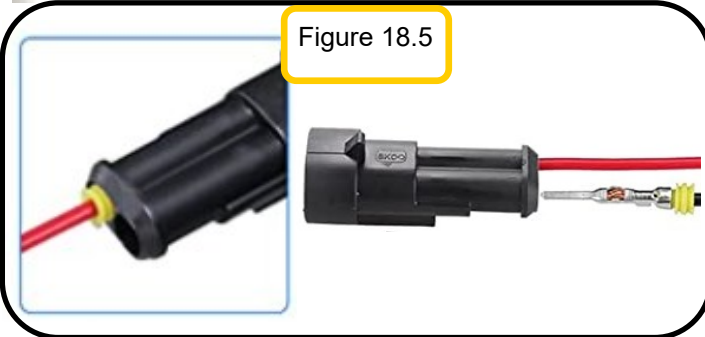

Be sure to align the terminal prongs up with the inside of the connector pin outs.

Carefully insert the terminals into their designated section. Figure 18.5.

Also be sure the terminals snap into position. You should feel or hear a click when they are correctly inserted.

Figure 18.6

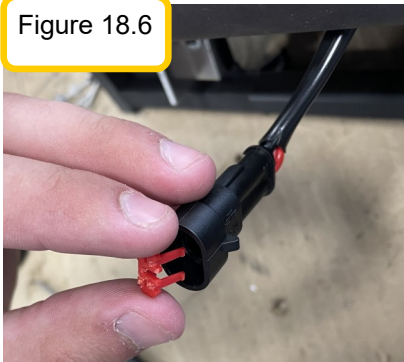
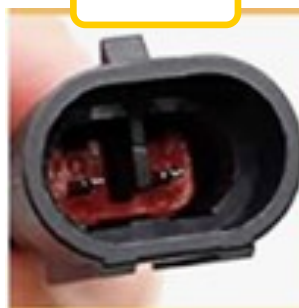

Figure 18.7



Pull on the wiring to be sure the connectors have been inserted completely.

If not already done:

Insert the red plastic piece into the top end of the connector. This will also click into place. Figure 18.6 and 18.7.

Silicone the grommet/wiring.

If there is no spoiler on the vehicle (regular cab trucks), please skip to the next page.

For vehicles that have a spoiler on the rear of the roof (double and crew cab models):

Please refer to this YouTube link for the Acari mount install.

Also please proceed to page 24 to view Acari's instructions for their portion of the install, then continue on page 19.

Removing the headliner and spoiler from the cab:
<https://www.youtube.com/watch?v=YGLkVlcCSlg>



Figure 20.1

Pictures to the left are for beacon/lightbar mounting references.
Figure 20.1, 20.2, and 20.3



Figure 20.3



Figure 20.2

Step 2: Disconnect OEM Light For non-spoiler CHMSL lights:

Remove the 3rd brake light on the CHMSL and disconnect the OEM harness. Figure 20.4 and Figure 20.5.



Figure 20.4

Step 3:

Locate the beacon/lightbar harness (67111).

Remove the cable gland off the beacon/lightbar harness. This will not be needed to the CHMSL mounted light install.

Connect the harness to the switch harness #2 (one of the remaining unused connectors) in the driver's foot well. Figure 20.6.

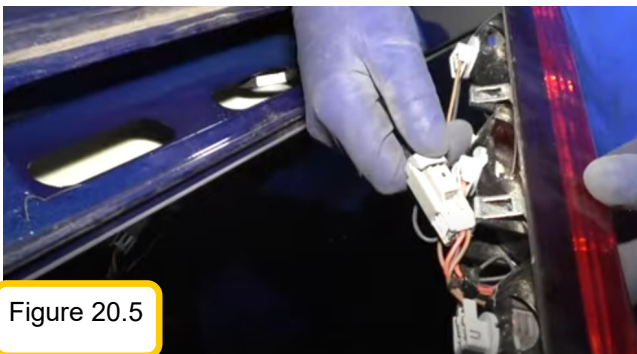
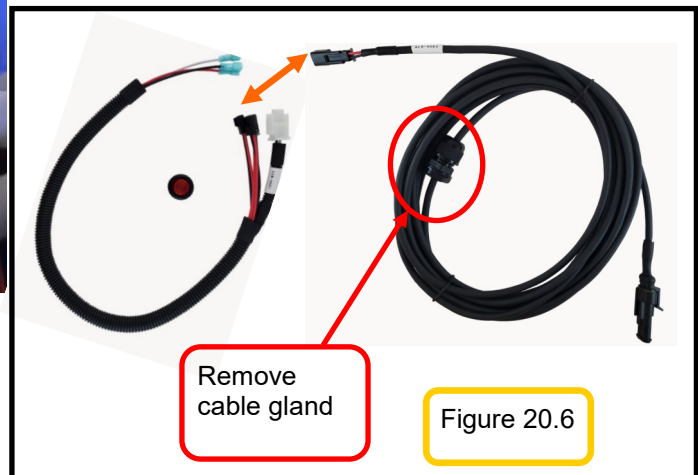

Figure 20.5



Remove cable gland

Figure 20.6

Beacon/Lightbar Install—If Applicable

Step 4: Routing (Refer to routing diagrams at the beginning of the instructions)

Route the beacon harness following the OEM harness rearward along the foot sill and then up the rear C pillar. Figure 21.1 and 21.2.

****BE SURE TO AVOID ALL SEAT BELT RETENTIONERS****

Step 5: Feed the fish tape through the CHMSL opening towards the driver's side C pillar. Tape the harness to the fish tape and pull through the CHMSL opening. Figure 21.3.

Make sure harness is tucked head liner and C pillar trim. Figure 21.4.

See pictures for routing references. Secure all wiring with cable ties and trim panels.

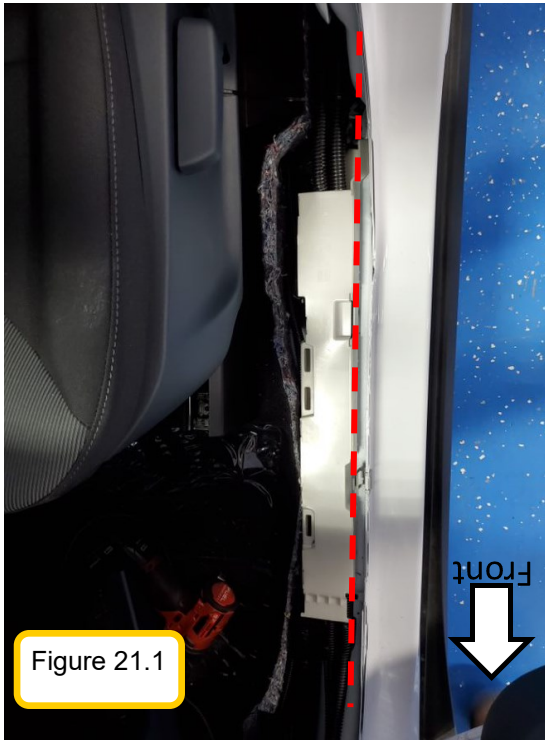
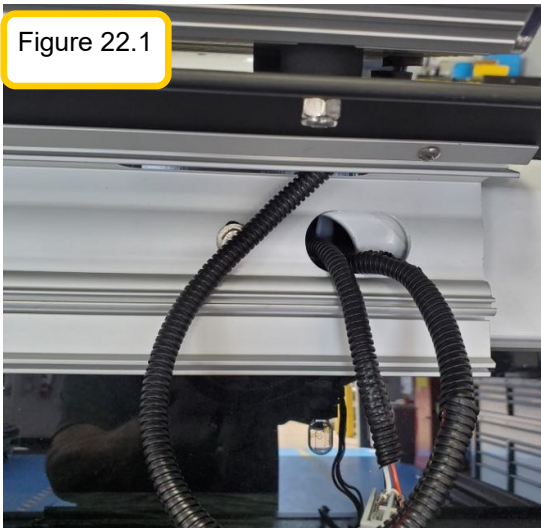

Figure 22.1



Step 5: Mounting the light:

Using the mount manufacturer supplied instructions, attach the mount to the vehicle body.

Pull the lightbar harness through the mount opening like seen in the picture to the left—before re-installing the OEM light and black trim plastic piece. Figure 22.1, 22.2, and 22.3.

Connect the beacon/lightbar harness with the beacon/lightbar.

Figure 22.2



Tape up all non-needed wires from the lightbar/beacon.

Assemble the rest of the needed lightbar/beacon mount pieces.

Re-connect all the OEM light wiring and attach the light back to the Acari mount/vehicle. Figure 22.4.

Figure 22.3



Figure 22.4





Insert the fuse into the inline-fuse holder on the power harness. The install is now complete. Secure all wiring with zip ties. Re-attach all trim. Re-assure all pass through holes have been silicone. Double check the functionality of the lights and switches.



Installation Guide:

Drill-Free Roof Top Mount

ACARI Talon

for 2019-20 GM & Chevrolet

1500 – 4500 with Spoiler Applique

ENGINEERING COMPANY, LLC

500 Main Street, Deep River, CT

Phone (860) 510-0134

Sales e-mail: sales@acariproducts.com

Safety First!

These instructions provide all the necessary directions and information to allow your ACARI product to be safely and properly installed. Before beginning the installation of your new ACARI product, please have the installer and the operator read these directions thoroughly. Important information regarding the safe installation and safe operation of your ACARI product is contained that could prevent serious damage and injury to yourself or others.

The ACARI RTM is designed to facilitate the quick and simple installation of devices normally mounted to the roof of a pickup truck. Our product provides a durable platform onto which these devices may be mounted without requiring holes to be drilled into the cab roof for fastening or wiring access. ACARI provides a system of weather-resistant gaskets and deflectors designed to redirect wind and moisture in common applications. **PLEASE NOTE: ACARI RTM is not designed to be weather-proof in the event of power washing, mechanical car washing, or other forces beyond normal highway operation.**

It is the responsibility of the owner/operator to periodically inspect the RTM to be sure the platform system remains secure and the weather resistant gasketing is snug.

The ACARI RTM is designed to provide a mounting platform for lighting, antennas, GPS, and other devices. In no way is the ACARI RTM to be used as a load bearing rack for ladders or other equipment or supplies. The recommended weight restriction of the ACARI RTM is **30 lbs.**

The ACARI RTM is designed to provide a mounting platform but in no way provides advice on the possible electronic effect of mounting various devices within any proximity to another. The ACARI RTM is manufactured of powder coated aluminum but is mounted to the vehicle with gaskets to provide a water-resistant bond and protect the finish of the vehicle. As such, the ACARI RTM **may not** be grounded to the vehicle without the installation technician applying an appropriate grounding mechanism.

MOUNTING THE UNIT:

The ACARI Talon Drill-Free Roof Top Mount (RTM) has been designed with a focus on simplicity of design and vehicle installation. As with any new task, the first installation will require greater time and effort than those that follow. We have outlined the essential tasks required with step by step instructions. There will be variations based on the options offered with the vehicle. Our experience was 55 minutes total time on our first install with a novice upfitter. By our fifth upfit we were down to 15-20 minutes

NOTE: To maximize protection of the factory finish of the Spoiler Applique, retain the product packaging to use in the assembly process.

1. **Vehicle Preparation:** Remove Body Side Rear Window Garnish Molding from quarter pylons on both sides of the rear interior of the cab. Per GM shop instructions, loosen cover, remove 7mm bolt, pull hook down and un-clip to remove, sliding down the safety belt assembly and out of the way.
2. Remove door frame trim molding along top and back edges and allow to hang in place.
3. Removing the headliner; find the screw cover plugs over the doorway and remove. Using an 8mm socket, remove the headliner mounting brackets above the doors and set aside. Carefully separate the rear edge of the headliner from the top of the window molding and unclip the two retainers and detach the wiring harness allowing the rear of the headliner to hang. Caution: the edge of the headliner panel and other vehicle components may be sharp. Protective gloves are recommended.
4. Using a 10 mm socket, remove the eight mounting nuts across the width of the spoiler applique.
5. Using a swivel head 10 mm drive, remove the four mounting bolts, two at each corner end.
6. With a team mate holding the spoiler applique from the exterior of the vehicle, compress the yellow bayonet clips with a pair of pliers and push through.
7. Remove the rubber wire harness gasket from the body of the vehicle and remove the spoiler applique to work bench.
8. Place the spoiler applique in an inverted position on a protective surface to prevent damage to the finish. Remove the four screws holding the Chimsel lamp housing and separate.
9. **Platform Preparation:** Open RTM package and remove all parts. Retain product packaging!
10. Mount and fasten lights and other apparatuses to be installed on the platform, attaching and fastening each to their manufacturers' installation requirements. **NOTE: any attachments may NOT use studs projecting greater than 1/2" or risk damage to spoiler applique finish.** All wiring should include 24 to 30 inch leads and connectors. At same time, make up the corresponding wire harness for connection inside the vehicle. Lengths with vary.

11. Invert the RTM with the attachments and place inside the retained shipping box as a cradle with the “C” tabs facing toward you. Hold the Spoiler Applique in an inverted position with the front edge facing toward you. Slide leading edge of Spoiler Applique into the “C” tabs channel slightly to the left of the center two studs. Pull apparatus wires through center opening of the Spoiler Applique, then lower onto the RTM. Slide the Spoiler Applique to the right to register the two center studs in the “C” tabs.
12. Re-lead the Chimsel lamp wire and re-install the lamp housing in the Spoiler Applique with the four screws. Confirm the apparatus wires are loose and free of pinching or abrasions.
13. Return the completed assembly to the roof of the vehicle and place on a work cloth to protect the factory finish, forward of the final location. Re-lead the Chimsel wire through the body and reinstall the factory gasket. GM provides three additional holes, each with a flexible watertight plug. **NOTE: The method of running the apparatus wiring through one or more of these holes in a watertight method is the sole responsibility of the upfitter/installer.**
14. Register the yellow bayonet clips in the appropriate holes and reinstall the Spoiler Applique onto the vehicle.
15. Run appropriate interior wiring for apparatus then complete steps 1 – 5 in reverse order to complete installation.



.....

USER DIRECT ONE YEAR WARRANTY

ACARI Engineering Company, LLC warrants products of its manufacture against defects in material and workmanship. This is provided that the product has been installed and operated in accordance with the manufacturers' recommendations. During the warranty period, an Authorized ACARI Repair Center will repair or replace (at its option) any parts or assemblies of the unit which disclose a defect in material or workmanship. The Repair Center will return the repaired unit, transportation cost prepaid.

The above warranty is between the first purchaser (ultimate user) only and ACARI Engineering Company, LLC (manufacture). No prior authorization is required for returning ACARI products for warranty consideration. Each ACARI product sold is covered only by the official warranty in effect at time of purchase.

This warranty is not applicable to any ACARI product that has failed due to abuse, misuse, improper installation, and excessive alterations to the product that affects, in the manufacture's judgment, intended use and service. ACARI will not be held liable for any incidental or consequential damages, and assumes no responsibility or liability for expenses incurred in the removal and/or re-installation of products requiring services and/or repair; nor the packaging, handling, and shipping to the Authorized ACARI Repair Center; nor the handling of products returned from the repair center after service or repair. **There are no other warranties, expressed or implied, including, but not limited to, any implied merchantability or fitness for a particular use.** ACARI Engineering Company, LLC reserves the right to modify this warranty statement at any time; or discontinue, modify, or upgrade any products of its manufacture with design improvements without prior notice.

This warranty gives you specific rights, and you may also have other rights which vary from state to state.

ACARI products are covered by a direct warranty for up to a maximum one year from date of purchase (not to exceed two years from the date of manufacture), with proof of purchase. In accordance with the policy statement described herein, the unit may be returned directly to the Authorized ACARI Repair Center for warranty consideration.

STEPS TO BE TAKEN FOR WARRANTY RETURN:

1. ACARI products are to be returned freight prepaid to the Authorized ACARI Repair Center.
2. A copy of the sales receipt must be returned with the defective unit to qualify for warranty coverage from date of purchase.
3. Include a short statement explaining the problem.
4. Include your name, address, and day-time telephone number.
5. ACARI and its Authorized Repair Centers will, via UPS, ship back the repaired unit **freight prepaid**, usually within a few days after its receipt.

The only AUTHORIZED ACARI REPAIR CENTER(S) are predetermined by the ACARI Factory via official listing obtained from ACARI Engineering Company, LLC.

PART NUMBER

13905-0

ITEM DESCRIPTION: WIRE TIE, NYLON 40Lb, 8.5" BLACK



MANUFACTURER: WAYTEK, INC. or equivalent
MANUFACTURERS PART NUMBER: 21093M or 21093C

SPECIFICATIONS: STANDARD CABLE TIE
 BLACK, NYLON
 8-1/2" LONG
 TENSILE STRENGTH: 40.0 LBS
 21093M = 1,000 quantity
 21093C = 100 quantity

SPECIAL NOTES: PART NUMBER IS BLACK.

SUPPLIED BY: THIS ITEM IS ADRIAN AVAILABLE!

PURCHASED PRODUCT DATA SHEET (PPDS)

THIS DRAWING/INFORMATION IS THE PROPERTY OF ADRIAN STEEL COMPANY AND IS NOT TO BE USED IN ANY MANNER THAT IS DETRIMENTAL TO THE INTEREST OF ADRIAN STEEL. COPYRIGHTS AND OR PATENTS THAT MAY BE THE PROPERTY OF APPLICABLE OWNERS MAY PROTECT INFORMATION AND/OR DRAWINGS OF SUPPLIED PRODUCTS.



ADRIAN STEEL
VAN AND PICKUP EQUIPMENT

906 JAMES STREET
ADRIAN, MI 49221
517-265-6194
WWW.ADRIANSTEEL.COM



WHEN INSTALLING EQUIPMENT IN OR ON VEHICLES CHECK FOR FUEL TANKS, FUEL LINES, CONTROL LINES AND ELECTRICAL WIRING BEFORE DRILLING! ALWAYS USE DRILL BITS WITH INTEGRAL STOPS WHENEVER POSSIBLE!

DRAWN BY MDG	DATE DRAWN 10/26/2006
ECN NUMBER 18021	ECN DATE 11/13/2015
PART WEIGHT 0.01 LBS.	REV. LEVEL D
PART NUMBER 13905-0	

PART NUMBER

26618-0

ITEM DESCRIPTION: SILICONE, 1oz. TUBE



SPECIFICATIONS: SU5005 RTV SILICONE
1oz. TUBE
CLEAR OR EQUIVALENT
SELF PIERCING CAP

SPECIAL NOTES:

SUPPLIED BY: THIS ITEM IS ADRIAN AVAILABLE!

PURCHASED PRODUCT DATA SHEET (PPDS)

THIS DRAWING/INFORMATION IS THE PROPERTY OF ADRIAN STEEL COMPANY AND IS NOT TO BE USED IN ANY MANNER THAT IS DETRIMENTAL TO THE INTEREST OF ADRIAN STEEL. COPYRIGHTS AND OR PATENTS THAT MAY BE THE PROPERTY OF APPLICABLE OWNERS MAY PROTECT INFORMATION AND/OR DRAWINGS OF SUPPLIED PRODUCTS.



ADRIAN STEEL
VAN AND PICKUP EQUIPMENT

906 JAMES STREET
ADRIAN, MI 49221
517-265-6194

WWW.ADRIANSTEEL.COM

CAUTION

WHEN INSTALLING EQUIPMENT IN OR ON VEHICLES CHECK FOR FUEL TANKS, FUEL LINES, CONTROL LINES AND ELECTRICAL WIRING BEFORE DRILLING! ALWAYS USE DRILL BITS WITH INTEGRAL STOPS WHENEVER POSSIBLE!

DRAWN BY
JLC

DATE DRAWN
7/21/2001

ECN NUMBER
16551

ECN DATE
7/22/2014

PART WEIGHT
0.02 LBS.

REV. LEVEL
C

PART NUMBER
26618-0

PART NUMBER

26618-0

ITEM DESCRIPTION: SILICONE, 1oz. TUBE



SPECIFICATIONS: SU5005 RTV SILICONE
1oz. TUBE
CLEAR OR EQUIVALENT
SELF PIERCING CAP

SPECIAL NOTES:

SUPPLIED BY: THIS ITEM IS ADRIAN AVAILABLE!

PURCHASED PRODUCT DATA SHEET (PPDS)

THIS DRAWING/INFORMATION IS THE PROPERTY OF ADRIAN STEEL COMPANY AND IS NOT TO BE USED IN ANY MANNER THAT IS DETRIMENTAL TO THE INTEREST OF ADRIAN STEEL. COPYRIGHTS AND OR PATENTS THAT MAY BE THE PROPERTY OF APPLICABLE OWNERS MAY PROTECT INFORMATION AND/OR DRAWINGS OF SUPPLIED PRODUCTS.



ADRIAN STEEL
VAN AND PICKUP EQUIPMENT

906 JAMES STREET
ADRIAN, MI 49221
517-265-6194

WWW.ADRIANSTEEL.COM

⚠ CAUTION ⚠

WHEN INSTALLING EQUIPMENT IN OR ON VEHICLES CHECK FOR FUEL TANKS, FUEL LINES, CONTROL LINES AND ELECTRICAL WIRING BEFORE DRILLING! ALWAYS USE DRILL BITS WITH INTEGRAL STOPS WHENEVER POSSIBLE!

DRAWN BY
JLC

DATE DRAWN
7/21/2001

ECN NUMBER
16551

ECN DATE
7/22/2014

PART WEIGHT
0.02 LBS.

REV. LEVEL
C

PART NUMBER
26618-0

PART NUMBER

36096-0

ITEM DESCRIPTION: GROMMET,RUBBER,1" ID



MANUFACTURER: CTW (or equiv.)
MANUFACTURERS PART NUMBER: G2930

SPECIFICATIONS: 1" I.D.
1-1/4" PANEL HOLE DIA.
3/16" MAX PANEL THICKNESS
1-1/2" O.D.
7/16" THICKNESS

SPECIAL NOTES: NONE

SUPPLIED BY: THIS ITEM IS ADRIAN AVAILABLE!

PURCHASED PRODUCT DATA SHEET (PPDS)

THIS DRAWING/INFORMATION IS THE PROPERTY OF ADRIAN STEEL COMPANY AND IS NOT TO BE USED IN ANY MANNER THAT IS DETRIMENTAL TO THE INTEREST OF ADRIAN STEEL. COPYRIGHTS AND OR PATENTS THAT MAY BE THE PROPERTY OF APPLICABLE OWNERS MAY PROTECT INFORMATION AND/OR DRAWINGS OF SUPPLIED PRODUCTS.



ADRIAN STEEL
VAN AND PICKUP EQUIPMENT

906 JAMES STREET
ADRIAN, MI 49221
517-265-6194

WWW.ADRIANSTEEL.COM

CAUTION

WHEN INSTALLING EQUIPMENT IN OR ON VEHICLES CHECK FOR FUEL TANKS, FUEL LINES, CONTROL LINES AND ELECTRICAL WIRING BEFORE DRILLING! ALWAYS USE DRILL BITS WITH INTEGRAL STOPS WHENEVER POSSIBLE!

DRAWN BY
HJE

DATE DRAWN
04/01/2008

ECN NUMBER
19252

ECN DATE
01/31/2017

PART WEIGHT
0.01 LBS.

REV. LEVEL
D

PART NUMBER
36096-0

ITEM DESCRIPTION: STROBE SWITCH DECAL SET

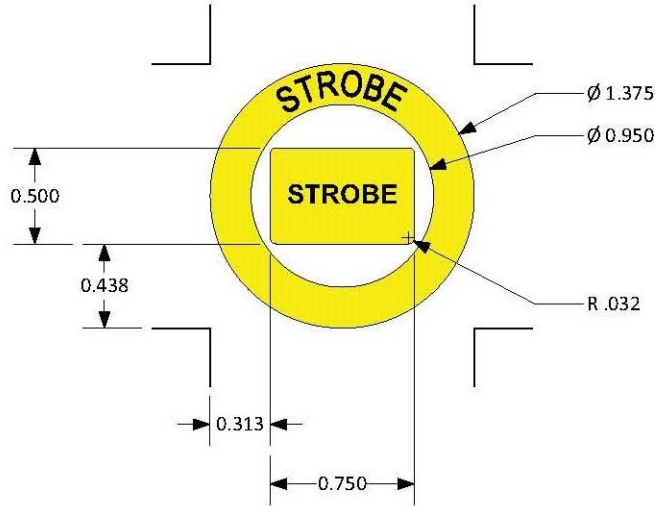

MANUFACTURER: VANNER
MANUFACTURERS PART NUMBER: TBD

SPECIFICATIONS: (1) Circular Yellow Decal (ID=0.950", OD=1.375") with "STROBE" in black letters
(1) Rectangular Yellow Decal (H=0.500", L=0.750") with "STROBE" in black letters

SPECIAL NOTES: For round rocker switch (OD=0.780") and Ford Transit Upfitter Switches.

SUPPLIED BY: THIS ITEM IS ADRIAN AVAILABLE!

PURCHASED PRODUCT DATA SHEET (PPDS)

THIS DRAWING/INFORMATION IS THE PROPERTY OF ADRIAN STEEL COMPANY AND IS NOT TO BE USED IN ANY MANNER THAT IS DETRIMENTAL TO THE INTEREST OF ADRIAN STEEL. COPYRIGHTS AND OR PATENTS THAT MAY BE THE PROPERTY OF APPLICABLE OWNERS MAY PROTECT INFORMATION AND/OR DRAWINGS OF SUPPLIED PRODUCTS.



**906 JAMES STREET
ADRIAN, MI 49221
517-265-6194
WWW.ADRIANSTEEL.COM**

⚠ CAUTION ⚠

WHEN INSTALLING EQUIPMENT IN OR ON VEHICLES CHECK FOR FUEL TANKS, FUEL LINES, CONTROL LINES AND ELECTRICAL WIRING BEFORE DRILLING! ALWAYS USE DRILL BITS WITH INTEGRAL STOPS WHENEVER POSSIBLE!

DRAWN BY RJB	DATE DRAWN 11/15/2017
ECN NUMBER XXXX	ECN DATE XXXXXX
PART WEIGHT 0.02 LBS.	REV. LEVEL A
PART NUMBER 55073	

REVISIONS			
REV	DESCRIPTION	DATE	REAE/CO

- NOTES:
1. MATERIAL : .002 YELLOW POLYESTER
 2. ARTWORK FROM D91XXXX-A PAGE 1, PMS BLACK
 3. .001 OVERLAMINATE
 4. ADHESIVE BACKED

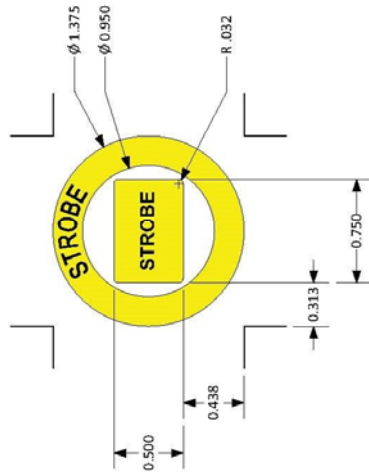

VANNER INCORPORATED HILLIARD, OHIO USA	
TOL. LABEL/METAL	.x ± .025 .xx ± .015 .xxx ± .005
TOL. CABLES	.xxx ± .25
DRNDATE	MEO 11/14/17
CHKDATE	XXX XXXXXX
TITLE:	LABEL, STROBE TXT, .95ID ROUND SWITCH
DRAWING/PART NO.	D01XXXX
SHEET	1 OF 1
REV	A
SCALE:	NONE
REAE/CO NO.:	XXXX
THIS DRAWING AND ALL INFORMATION CONTAINED HEREIN IS THE PROPERTY OF VANNER INC. AND MAY NOT BE COPIED, REPRODUCED OR DIVULGED TO UNAUTHORIZED PERSONS WITHOUT THE EXPRESS WRITTEN CONSENT OF VANNER INC. IT IS PROVIDED SOLELY FOR THE CONVENIENCE OF THE USER AND SHALL BE RETURNED UPON REQUEST.	

PART NUMBER
55073

THIS DRAWING/INFORMATION IS THE PROPERTY OF ADRIAN STEEL COMPANY AND IS NOT TO BE USED IN ANY MANNER THAT IS DETRIMENTAL TO THE INTEREST OF ADRIAN STEEL. COPYRIGHTS AND OR PATENTS THAT MAY BE THE PROPERTY OF APPLICABLE OWNERS MAY PROTECT INFORMATION AND/OR DRAWINGS OF SUPPLIED PRODUCTS.



906 JAMES STREET
ADRIAN, MI 49221
517-265-6194
WWW.ADRIANSTEEL.COM



WHEN INSTALLING EQUIPMENT IN OR ON VEHICLES CHECK FOR FUEL TANKS, FUEL LINES, CONTROL LINES AND ELECTRICAL WIRING BEFORE DRILLING! ALWAYS USE DRILL BITS WITH INTEGRAL STOPS WHENEVER POSSIBLE!

DRAWN BY RJB	DATE DRAWN 11/15/2017
ECN NUMBER XXXX	ECN DATE XXXXXXX
PART WEIGHT 0.02 LBS.	REV. LEVEL A
PART NUMBER 55073	

LOC | QTY | Part # | Description | Size

Material: IJ39 | Lamination: 8518

- 1: 6039597.Strobe Switch-1.52" x 2.07"



Note: Part will not be weeded, just cut.

Kit# 8001872 | Adrian Steel Part # 55073

06/01/2023 • JY
© 2022 DISTYLL Graphics Solutions. All rights reserved.

ASCO REV.1 6/14/2023

<p>DISTYLL GRAPHIC SOLUTIONS</p> <p>FINAL DESIGN</p>	CLIENT NAME:		Switch Decals		O-ID: O15319-1
	Adrian Steel				Rev #: XXXX
	DATE:	DESIGNER:			Opt #: A
O5/31/2023	TRN				

Please check information to confirm accurate vehicle specifications.

CLEANING INSTRUCTIONS All surfaces must be considered contaminated. Clean the vehicle surface immediately before applying the film. Dust and other contaminants can collect quickly on the surface and prevent the film from adhering properly. Even a freshly painted surface can collect dust before graphics can be applied.

For the best success with the films recommended for vehicle graphics, always apply the graphics when the air and vehicle surface are both above 60°F (16°C) and below 90°F (32°C) before beginning the installation.

PURCHASED COMPONENT KEY FEATURES

DESCRIPTION OF REQUIREMENTS

DIMENSIONAL REQUIREMENTS (AS SHOWN ON DRAWING)

N/A

LOAD/RATING REQUIREMENT

N/A

MATERIAL REQUIREMENT

N/A

PACKAGING REQUIREMENT

N/A

OTHER REQUIREMENTS

Note:
This is also from HellermannTyton:
Their Part Number is 156-00592



THIS DRAWING IS THE PROPERTY OF ADRIAN STEEL COMPANY AND IS NOT TO BE USED IN ANY MANNER DETRIMENTAL TO THE INTERESTS OF ADRIAN STEEL COMPANY

TOLERANCES & INSPECTION

UNLESS OTHERWISE SPECIFIED

ALL BEND ANGLES ARE 90 DEGREES

ALL DIMENSIONS ARE IN INCHES.

REFERENCE DIMENSIONS (X.XXX)
DO NOT REQUIRE INSPECTION

FEATURES	HOLES/SLOTS	ANGLES
0.0 = ± .125	0.0 = ± .062	0° = ± 2°
0.00 = ± .062	0.00 = ± .031	0.0° = ± 1°
0.000 = ± .031	0.000 = ± .015	

Material Thickness: per ASTM Std.
Weld Callouts per AWS

RELEASE & REVISIONS

INITIAL ECN: **22671**

CURRENT ECN: **22671**

ECN DESCRIPTION:

RELEASE TO PRODUCTION

REVISED BY: **EMS**

PURCHASED COMPONENT

REFERENCED SUPPLIER AND/OR MANUFACTURER

Fastenal

REFERENCED SUPPLIER AND/OR MANUFACTURER PART NUMBER

0787863

COLOR (ONLY LIST IF COLOR SPECIFIC)

COMODITY ITEM (Y/N) (YES = ALL DIMENSIONS AND NOTES ARE REFERENCE)
(NOTE: DIMENSIONS AND FEATURES MAY VARY FOR A COMODITY ITEM.)

NO

PRINTED DOCUMENT IS UNCONTROLLED

Sheet 1 of 1

PART / PRODUCT IDENTIFICATION



ADRIAN STEEL®

ADRIAN STEEL COMPANY
906 JAMES STREET, ADRIAN, MI 49221

REVISION LEVEL

A

MAT'L USED:

DESIGNED BY: **EMS**

DESCRIPTION:

Clip, Black UV Tie, HellermannTyton

WEIGHT (Lbs.): **0.5**

SEGMENT CODE: **ELE**

PART NUMBER: **59713**

PURCHASED COMPONENT KEY FEATURES

DESCRIPTION OF REQUIREMENTS

DIMENSIONAL REQUIREMENTS (AS SHOWN ON DRAWING)

N/A

LOAD/RATING REQUIREMENT

N/A

MATERIAL REQUIREMENT

N/A

PACKAGING REQUIREMENT

N/A

OTHER REQUIREMENTS



THIS DRAWING IS THE PROPERTY OF ADRIAN STEEL COMPANY AND IS NOT TO BE USED IN ANY MANNER DETRIMENTAL TO THE INTERESTS OF ADRIAN STEEL COMPANY

PRINTED DOCUMENT IS UNCONTROLLED

Sheet 1 of 1

TOLERANCES & INSPECTION

UNLESS OTHERWISE SPECIFIED

ALL BEND ANGLES ARE 90 DEGREES

ALL DIMENSIONS ARE IN INCHES.

REFERENCE DIMENSIONS (X.XXX)
DO NOT REQUIRE INSPECTION

FEATURES	HOLES/SLOTS	ANGLES
0.0 = ± .125	0.0 = ± .062	0° = ± 2°
0.00 = ± .062	0.00 = ± .031	0.0° = ± 1°
0.000 = ± .031	0.000 = ± .015	

Material Thickness: per ASTM Std.
Weld Callouts per AWS

RELEASE & REVISIONS

INITIAL ECN: **25378**

CURRENT ECN: **25378**

ECN DESCRIPTION:

RELEASE FOR PRODUCTION

REVISED BY:

PURCHASED COMPONENT

REFERENCED SUPPLIER AND/OR MANUFACTURER

AAMP GLOBAL

REFERENCED SUPPLIER AND/OR MANUFACTURER PART NUMBER

67095 OR PWR-HAR4

COLOR (ONLY LIST IF COLOR SPECIFIC)

COMODITY ITEM (Y/N) (YES = ALL DIMENSIONS AND NOTES ARE REFERENCE)
(NOTE: DIMENSIONS AND FEATURES MAY VARY FOR A COMODITY ITEM.)

NO

PART / PRODUCT IDENTIFICATION



ADRIAN STEEL®

ADRIAN STEEL COMPANY
906 JAMES STREET, ADRIAN, MI 49221

REVISION LEVEL

A

MAT'L USED: **PURCHASED**

DESIGNED BY: **E.BURKE**

DESCRIPTION: **POWER HARNESS EXTERIOR 4**

WEIGHT (Lbs.): **0.2**

SEGMENT CODE: **ELE**

PART NUMBER: **67095**

Coverings	
Id	Assembly
[7]	
[8]	

Notes	
①	Lock Tape Loom with Tesa 51036
②	Add 15A Mini Fuse
③	Add rubber grommet over harness loom; 150mm behind C2

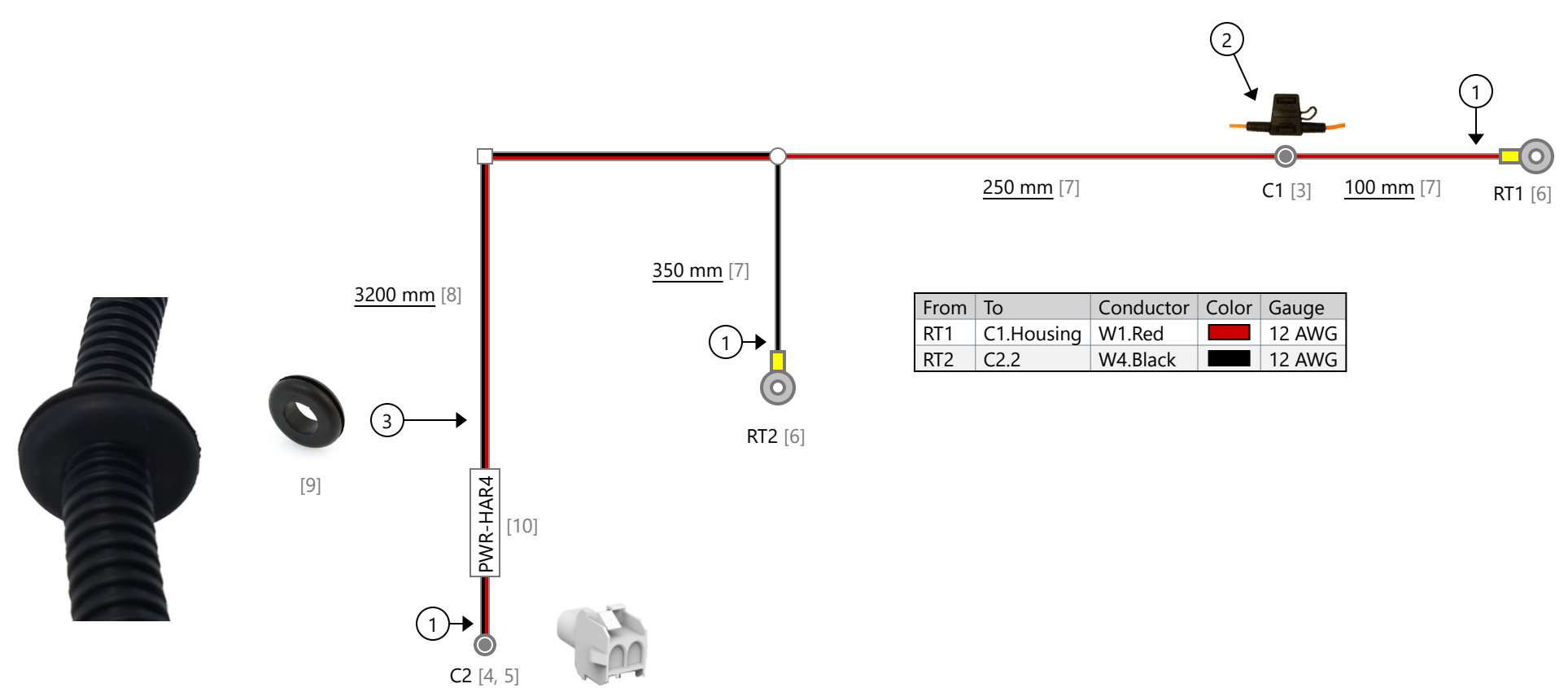

From	To	Conductor	Color	Gauge
RT1	C1.Housing	W1.Red		12 AWG
RT2	C2.2	W4.Black		12 AWG

From	To	Color	Gauge
C2.1	C1.Housing		12 AWG
C2.2	RT2		12 AWG



UNLESS OTHERWISE SPECIFIED DIMENSIONS ARE IN MILLIMETERS [INCHES] TOLERANCES: ±5MM		Name	Date
DESIGNED BY		Bennet Fisher	11/5/2021
ENGINEERING APPROVAL		----	----
MANUFACTURING APPROVAL		----	----
REVISION APPROVAL		----	----
QUALITY ASSURANCE		----	----

AAMP
— ADVANCING VEHICLE TECHNOLOGY —

Part Number: PWR-HAR4	Revision: ----
Description: Exterior Light Battery Harness	Sheet: 1 of 1

Revisions			
Rev.	Date	Author	Description
A	11/5/2021	Bennet Fisher	Initial Drawing

PURCHASED COMPONENT KEY FEATURES

DESCRIPTION OF REQUIREMENTS

DIMENSIONAL REQUIREMENTS (AS SHOWN ON DRAWING)

N/A

LOAD/RATING REQUIREMENT

N/A

MATERIAL REQUIREMENT

N/A

PACKAGING REQUIREMENT

N/A

OTHER REQUIREMENTS



THIS DRAWING IS THE PROPERTY OF ADRIAN STEEL COMPANY AND IS NOT TO BE USED IN ANY MANNER DETRIMENTAL TO THE INTERESTS OF ADRIAN STEEL COMPANY

TOLERANCES & INSPECTION

UNLESS OTHERWISE SPECIFIED

ALL BEND ANGLES ARE 90 DEGREES

ALL DIMENSIONS ARE IN INCHES.

REFERENCE DIMENSIONS (X.XXX)
DO NOT REQUIRE INSPECTION

FEATURES	HOLES/SLOTS	ANGLES
0.0 = ± .125	0.0 = ± .062	0° = ± 2°
0.00 = ± .062	0.00 = ± .031	0.0° = ± 1°
0.000 = ± .031	0.000 = ± .015	

Material Thickness: per ASTM Std.
Weld Callouts per AWS

RELEASE & REVISIONS

INITIAL ECN: **25378**

CURRENT ECN: **25378**

ECN DESCRIPTION:

RELEASE FOR PRODUCTION

REVISED BY:

PURCHASED COMPONENT

REFERENCED SUPPLIER AND/OR MANUFACTURER

AAMP GLOBAL

REFERENCED SUPPLIER AND/OR MANUFACTURER PART NUMBER

SSW-HAR1 OR 67097

COLOR (ONLY LIST IF COLOR SPECIFIC)

COMODITY ITEM (Y/N) (YES = ALL DIMENSIONS AND NOTES ARE REFERENCE)
(NOTE: DIMENSIONS AND FEATURES MAY VARY FOR A COMODITY ITEM.)

NO

PRINTED DOCUMENT IS UNCONTROLLED

Sheet 1 of 1

PART / PRODUCT IDENTIFICATION



ADRIAN STEEL®

ADRIAN STEEL COMPANY
906 JAMES STREET, ADRIAN, MI 49221

REVISION LEVEL

A

MAT'L USED: **PURCHASED**

DESIGNED BY: **E.BURKE**

DESCRIPTION: **SWITCH HARNESS 1 EXTERIOR LIGHTING**

WEIGHT (Lbs.): **0.2**

SEGMENT CODE: **ELE**

PART NUMBER: **67097**

Coverings	
Id	Assembly
[12]	

Notes	
①	Lock Tape Loom with Tesa 51608
②	75mm between end of loom and Quick Connects

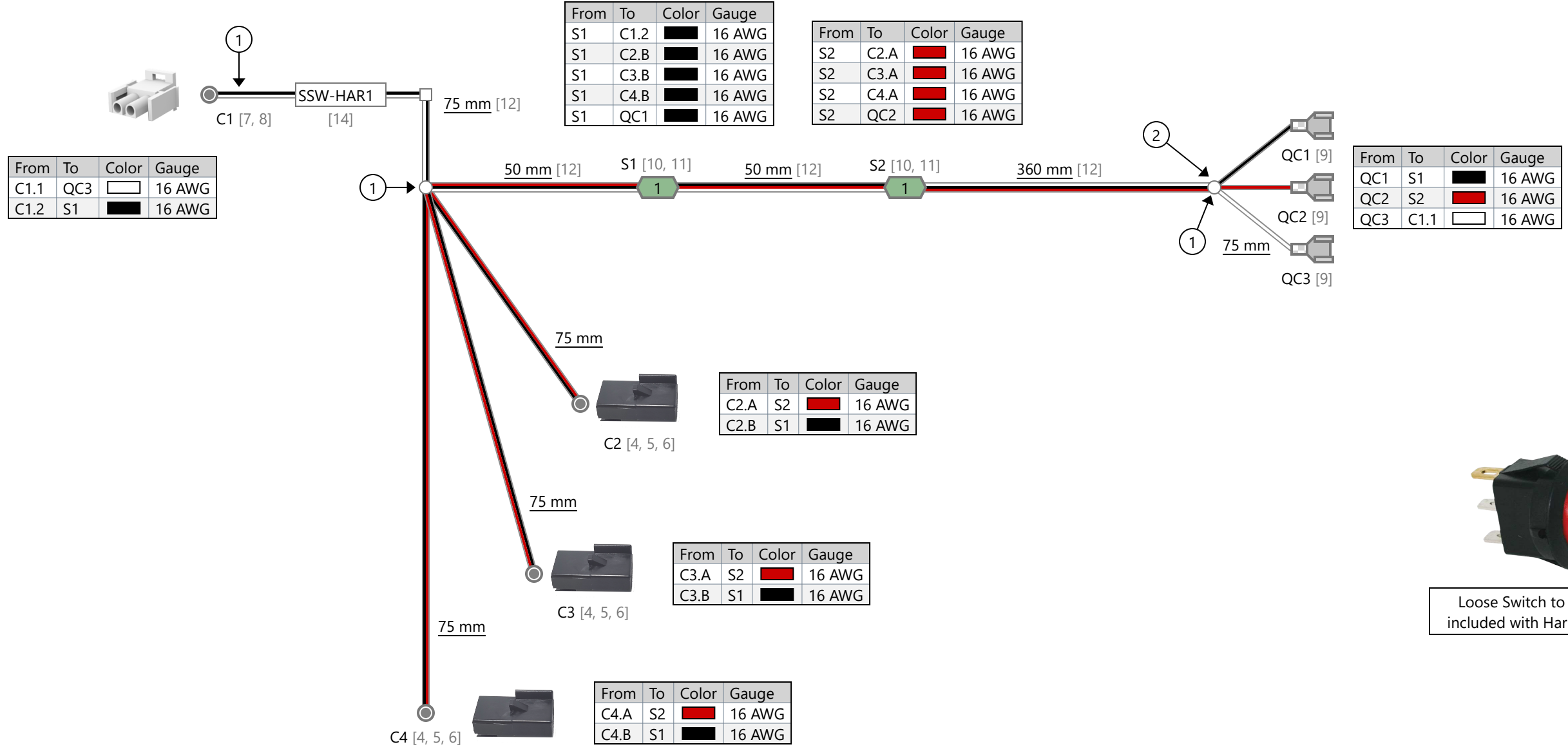

Revisions			
Rev.	Date	Author	Description
A	11/5/2021	Bennet Fisher	Initial Drawing

UNLESS OTHERWISE SPECIFIED DIMENSIONS ARE IN MILLIMETERS (INCHES) TOLERANCES: ±5MM		Name	Date
DESIGNED BY		Bennet Fisher	11/5/2021
ENGINEERING APPROVAL		----	----
MANUFACTURING APPROVAL		----	----
REVISION APPROVAL		----	----
QUALITY ASSURANCE		----	----

AAMP
— ADVANCING VEHICLE TECHNOLOGY —

Part Number: SSW-HAR1	Revision: ----
Description: Strobe Switch Harness - 3 Outputs	Sheet: 1 of 1

PURCHASED COMPONENT KEY FEATURES

DESCRIPTION OF REQUIREMENTS

DIMENSIONAL REQUIREMENTS (AS SHOWN ON DRAWING)

N/A

LOAD/RATING REQUIREMENT

N/A

MATERIAL REQUIREMENT

N/A

PACKAGING REQUIREMENT

N/A

OTHER REQUIREMENTS



THIS DRAWING IS THE PROPERTY OF ADRIAN STEEL COMPANY AND IS NOT TO BE USED IN ANY MANNER DETRIMENTAL TO THE INTERESTS OF ADRIAN STEEL COMPANY

TOLERANCES & INSPECTION

UNLESS OTHERWISE SPECIFIED

ALL BEND ANGLES ARE 90 DEGREES

ALL DIMENSIONS ARE IN INCHES.

REFERENCE DIMENSIONS (X.XXX)

DO NOT REQUIRE INSPECTION

FEATURES	HOLES/SLOTS	ANGLES
0.0 = ± .125	0.0 = ± .062	0° = ± 2°
0.00 = ± .062	0.00 = ± .031	0.0° = ± 1°
0.000 = ± .031	0.000 = ± .015	

Material Thickness: per ASTM Std.
Weld Callouts per AWS

RELEASE & REVISIONS

INITIAL ECN: **25378**

CURRENT ECN: **26321**

ECN DESCRIPTION:

RELEASE FOR PRODUCTION

REVISED BY:

PURCHASED COMPONENT

REFERENCED SUPPLIER AND/OR MANUFACTURER

AAMP GLOBAL

REFERENCED SUPPLIER AND/OR MANUFACTURER PART NUMBER

BLB-HAR1 OR 67111

COLOR (ONLY LIST IF COLOR SPECIFIC)

COMODITY ITEM (Y/N) (YES = ALL DIMENSIONS AND NOTES ARE REFERENCE)
(NOTE: DIMENSIONS AND FEATURES MAY VARY FOR A COMODITY ITEM.)

NO

PRINTED DOCUMENT IS UNCONTROLLED

Sheet 1 of 1

PART / PRODUCT IDENTIFICATION



ADRIAN STEEL

ADRIAN STEEL COMPANY
906 JAMES STREET, ADRIAN, MI 49221

REVISION LEVEL

B

MAT'L USED:

PURCHASED

DESIGNED BY: **E.BURKE**

DESCRIPTION:

BEACON/LIGHTBAR HARNESS 1

WEIGHT (Lbs.):

0.2

SEGMENT CODE:

EBE

PART NUMBER: **67111**

Bill of Materials				
Id	Type	Manufacturer	Part Number	Quantity
1	Cable		16AWG 2C FT2 TPU Cable	4620 mm
2	Connector	Aptiv	12047663	1
3	Contact	Aptiv	12047581	2
4	Lock	Aptiv	12047665	1
5	Heat Shrink		Adhesive-Lined Heat Shrink	2
6	Connector	TE Connectivity	282080-1	1
7	Contact	TE Connectivity	282110-1	2
8	Wire Seal	TE Connectivity	281934-2	2
9	Connector	TE Connectivity	282104-1	1
10	Wire Seal	TE Connectivity	282081-1	2
11	Label		Heat Shrink Style Label	1

- Notes
- Heat shrink cable jacket and wire 20mm behind connector (Heat shrink = 38mm long)
 - Place adhesive lined heat shrink over C2 connector wire cavities and cable jacket (Heat shrink = 38mm long)
 - Plug C3 into C2
 - C3 Cavities are sealed

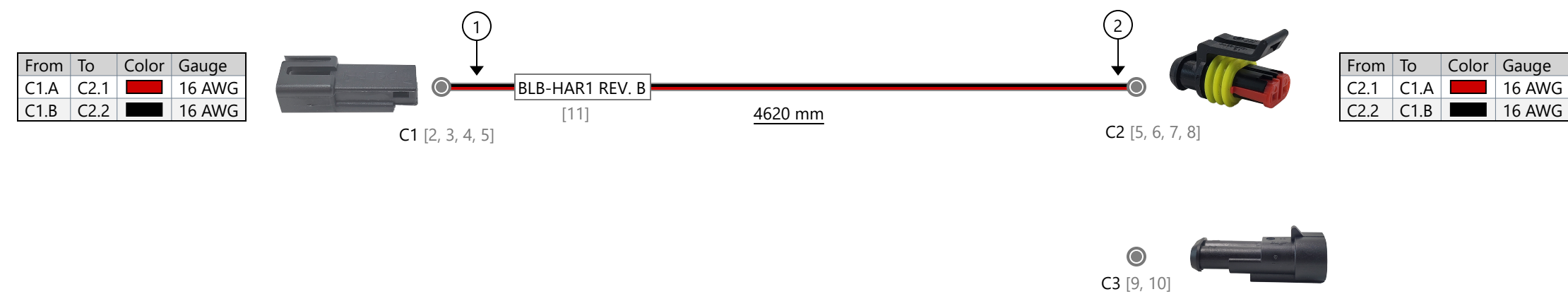

Revisions			
Rev.	Date	Author	Description
	11/5/2021	Bennet Fisher	Initial Drawing
	3/21/2022	Bennet Fisher	Added 300mm to harness; changed female connector
A	4/26/2022	Bennet Fisher	Added adhesive lined heat shrink to C2
B	4/3/2023	Bennet Fisher	Removed cable gland from harness

<p>UNLESS OTHERWISE SPECIFIED DIMENSIONS ARE IN MILLIMETERS [INCHES] TOLERANCES: ±5MM</p> <p>PROPRIETARY AND CONFIDENTIAL</p> <p>THE INFORMATION CONTAINED IN THIS DRAWING IS THE SOLE PROPERTY OF AAMP GLOBAL. ANY REPRODUCTION IN PART OR AS A WHOLE WITHOUT THE WRITTEN PERMISSION OF AAMP GLOBAL IS PROHIBITED.</p>		Name	Date	
	Designed By	Bennet Fisher	04/26/2022	
	Engineering Approval			
	Manufacturing Approval			
	Revision Approval			
Quality Assurance				
	Part Number: BLB-HAR1 REV. B_		Revision: B	
	Description:		Sheet:	
	Beacon/Light Bar Harness - 4.62 Meters		1	

PURCHASED COMPONENT KEY FEATURES

DESCRIPTION OF REQUIREMENTS

DIMENSIONAL REQUIREMENTS (AS SHOWN ON DRAWING)

N/A

LOAD/RATING REQUIREMENT

N/A

MATERIAL REQUIREMENT

N/A

PACKAGING REQUIREMENT

N/A

OTHER REQUIREMENTS

WHELEN LIGHTBAR: R2LPPCA WITH EXTERIOR PLUG AND PLAY CONNECTOR CLEAR LENS AMBER LED'S

CUSTOM R2LPPCA WITH W446, WPF. 2 SOCK CONNECTR KIT AMP WITH LOOM / GROMET / PATTERN WIRE TAPE / SETTING OF THE PATTERN

WHELEN PART NUMBER: R2LPPCA-AS CUSTOM / 01-0689088C1P0



THIS DRAWING IS THE PROPERTY OF ADRIAN STEEL COMPANY AND IS NOT TO BE USED IN ANY MANNER DETRIMENTAL TO THE INTERESTS OF ADRIAN STEEL COMPANY

TOLERANCES & INSPECTION

UNLESS OTHERWISE SPECIFIED

ALL BEND ANGLES ARE 90 DEGREES

ALL DIMENSIONS ARE IN INCHES.

REFERENCE DIMENSIONS (X.XXX)
DO NOT REQUIRE INSPECTION

FEATURES	HOLES/SLOTS	ANGLES
0.0 = ± .125	0.0 = ± .062	0° = ± 2°
0.00 = ± .062	0.00 = ± .031	0.0° = ± 1°
0.000 = ± .031	0.000 = ± .015	

Material Thickness: per ASTM Std.
Weld Callouts per AWS

RELEASE & REVISIONS

INITIAL ECN: **25921**

CURRENT ECN: **28678**

ECN DESCRIPTION:

Add Updated Part Number to PPDS

REVISED BY: **LJK**

PURCHASED COMPONENT

REFERENCED SUPPLIER AND/OR MANUFACTURER

WHELEN

REFERENCED SUPPLIER AND/OR MANUFACTURER PART NUMBER

R2LPPCA-AS CUSTOM / 01-0689088C1P0

COLOR (ONLY LIST IF COLOR SPECIFIC)

CLEAR LENS / AMBER LED'S

COMODITY ITEM (Y/N) (YES = ALL DIMENSIONS AND NOTES ARE REFERENCE)
(NOTE: DIMENSIONS AND FEATURES MAY VARY FOR A COMODITY ITEM.)

NO

PRINTED DOCUMENT IS UNCONTROLLED

Sheet 1 of 1

PART / PRODUCT IDENTIFICATION



ADRIAN STEEL®

ADRIAN STEEL COMPANY
906 JAMES STREET, ADRIAN, MI 49221

REVISION LEVEL

B

MAT'L USED: **PURCHASED**

DESIGNED BY: **EMB**

DESCRIPTION: **WHELEN LP LGHTBR AM W/CON**

WEIGHT (Lbs.): **1.5**

SEGMENT CODE: **EBE**

PART NUMBER: **67692**

PURCHASED COMPONENT KEY FEATURES

DESCRIPTION OF REQUIREMENTS

DIMENSIONAL REQUIREMENTS (AS SHOWN ON DRAWING)

N/A

LOAD/RATING REQUIREMENT

N/A

MATERIAL REQUIREMENT

N/A

PACKAGING REQUIREMENT

N/A

OTHER REQUIREMENTS

ACARI CHMSL NO DRILL MOUNT FOR SILVERADO 1500 AND HD - NO SPOILER

RTM-101-LP-WT KIT

INCLUDES MOUNTING HARDWARE

DOES NOT NCLUDE LIGHTBAR



THIS DRAWING IS THE PROPERTY OF ADRIAN STEEL COMPANY AND IS NOT TO BE USED IN ANY MANNER DETRIMENTAL TO THE INTERESTS OF ADRIAN STEEL COMPANY

TOLERANCES & INSPECTION

UNLESS OTHERWISE SPECIFIED

ALL BEND ANGLES ARE 90 DEGREES

ALL DIMENSIONS ARE IN INCHES.

REFERENCE DIMENSIONS (X.XXX)
DO NOT REQUIRE INSPECTION

FEATURES	HOLES/SLOTS	ANGLES
0.0 = ± .125	0.0 = ± .062	0° = ± 2°
0.00 = ± .062	0.00 = ± .031	0.0° = ± 1°
0.000 = ± .031	0.000 = ± .015	

Material Thickness: per ASTM Std.
Weld Callouts per AWS

RELEASE & REVISIONS

INITIAL ECN: **25944**

CURRENT ECN: **25944**

ECN DESCRIPTION:

RELEASE TO PRODUCTION

REVISED BY: **N/A**

PURCHASED COMPONENT

REFERENCED SUPPLIER AND/OR MANUFACTURER

ACARI

REFERENCED SUPPLIER AND/OR MANUFACTURER PART NUMBER

RTM-101-LP-WT

COLOR (ONLY LIST IF COLOR SPECIFIC)

N/A

COMODITY ITEM (Y/N) (YES = ALL DIMENSIONS AND NOTES ARE REFERENCE)
(NOTE: DIMENSIONS AND FEATURES MAY VARY FOR A COMODITY ITEM.)

NO

PRINTED DOCUMENT IS UNCONTROLLED

Sheet 1 of 1

PART / PRODUCT IDENTIFICATION



ADRIAN STEEL®

ADRIAN STEEL COMPANY
906 JAMES STREET, ADRIAN, MI 49221

REVISION LEVEL

A

MAT'L USED: **PURCHASED**

DESIGNED BY: **EMB**

DESCRIPTION: **MOUNT, CHMSL LP SI WT**

WEIGHT (Lbs.): **5.00**

SEGMENT CODE: **EBE**

PART NUMBER: **69468**

PURCHASED COMPONENT KEY FEATURES

DESCRIPTION OF REQUIREMENTS

DIMENSIONAL REQUIREMENTS (AS SHOWN ON DRAWING)

N/A

LOAD/RATING REQUIREMENT

N/A

MATERIAL REQUIREMENT

N/A

PACKAGING REQUIREMENT

N/A

OTHER REQUIREMENTS

**RUBBER GROMMET:
MCMaster-CARR 9600K33**

**INNER DIAMETER: 3/8"
PANEL HOLE DIAMETER: 7/16"
PANEL THICKNESS: 3/32"**

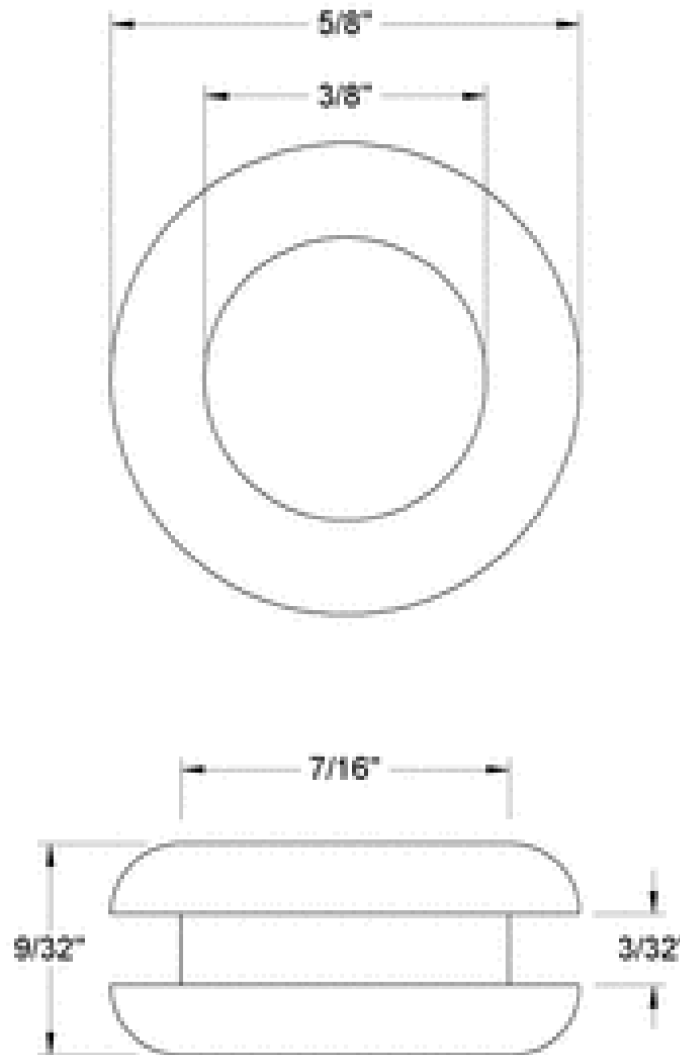

THIS DRAWING IS THE PROPERTY OF ADRIAN STEEL COMPANY AND IS NOT TO BE USED IN ANY MANNER DETRIMENTAL TO THE INTERESTS OF ADRIAN STEEL COMPANY

TOLERANCES & INSPECTION

UNLESS OTHERWISE SPECIFIED

ALL BEND ANGLES ARE 90 DEGREES

ALL DIMENSIONS ARE IN INCHES.

REFERENCE DIMENSIONS (X.XXX)
DO NOT REQUIRE INSPECTION

FEATURES	HOLES/SLOTS	ANGLES
0.0 = ± .125	0.0 = ± .062	0° = ± 2°
0.00 = ± .062	0.00 = ± .031	0.0° = ± 1°
0.000 = ± .031	0.000 = ± .015	

Material Thickness: per ASTM Std.
Weld Callouts per AWS

RELEASE & REVISIONS

INITIAL ECN: **26411**

CURRENT ECN: **26411**

ECN DESCRIPTION:

RELEASE TO PRODUCTION

REVISED BY: **N/A**

PURCHASED COMPONENT

REFERENCED SUPPLIER AND/OR MANUFACTURER

MCMaster-CARR

REFERENCED SUPPLIER AND/OR MANUFACTURER PART NUMBER

9600K33

COLOR (ONLY LIST IF COLOR SPECIFIC)

BLACK/RUBBER

COMODITY ITEM (Y/N) (YES = ALL DIMENSIONS AND NOTES ARE REFERENCE)
(NOTE: DIMENSIONS AND FEATURES MAY VARY FOR A COMODITY ITEM.)

NO

PRINTED DOCUMENT IS UNCONTROLLED

Sheet 1 of 1

PART / PRODUCT IDENTIFICATION



ADRIAN STEEL®

ADRIAN STEEL COMPANY
906 JAMES STREET, ADRIAN, MI 49221

REVISION LEVEL

A

MAT'L USED: **PURCHASED**

DESIGNED BY: **EMB**

DESCRIPTION: **GROMMET, 3/8"ID 7/16"OD**

WEIGHT (Lbs.): **0.01**

SEGMENT CODE: **EBE**

PART NUMBER: **70805**