

CATALOG NUMBER

Wire Harness

69281

Backup Alarm



PRODUCT FEATURES

- This product is compatible with the Chevy Colorado.
- Included in this kit is a white noise backup alarm (61501) and a wire harness (64014).
- There are no OEM options required with this product.
- This kit has no OEM options that it is not compatible with.
- This kit does not work for model year 2024+.

Model Year Validated:

2023

PURCHASED COMPONENT KEY FEATURES

DESCRIPTION OF REQUIREMENTS

DIMENSIONAL REQUIREMENTS (AS SHOWN ON DRAWING)

N/A

LOAD/RATING REQUIREMENT

N/A

MATERIAL REQUIREMENT

N/A

PACKAGING REQUIREMENT

N/A

OTHER REQUIREMENTS

Note:

AAMP Part # BUA-97WNC



THIS DRAWING IS THE PROPERTY OF ADRIAN STEEL COMPANY AND IS NOT TO BE USED IN ANY MANNER DETRIMENTAL TO THE INTERESTS OF ADRIAN STEEL COMPANY

TOLERANCES & INSPECTION

UNLESS OTHERWISE SPECIFIED

ALL BEND ANGLES ARE 90 DEGREES

ALL DIMENSIONS ARE IN INCHES.

REFERENCE DIMENSIONS (X.XXX)
DO NOT REQUIRE INSPECTION

FEATURES	HOLES/SLOTS	ANGLES
0.0 = ± .125	0.0 = ± .062	0° = ± 2°
0.00 = ± .062	0.00 = ± .031	0.0° = ± 1°
0.000 = ± .031	0.000 = ± .015	

Material Thickness: per ASTM Std.
Weld Callouts per AWS

RELEASE & REVISIONS

INITIAL ECN: **23456**

CURRENT ECN: **25415**

ECN DESCRIPTION:

Revise MPN on Alarm PPDS

REVISED BY: **JLT**

PURCHASED COMPONENT

REFERENCED SUPPLIER AND/OR MANUFACTURER

AAMP

REFERENCED SUPPLIER AND/OR MANUFACTURER PART NUMBER

BUA-97WNC

COLOR (ONLY LIST IF COLOR SPECIFIC)

COMODITY ITEM (Y/N) (YES = ALL DIMENSIONS AND NOTES ARE REFERENCE)
(NOTE: DIMENSIONS AND FEATURES MAY VARY FOR A COMODITY ITEM.)

NO

PRINTED DOCUMENT IS UNCONTROLLED

Sheet 1 of 1

PART / PRODUCT IDENTIFICATION



ADRIAN STEEL®

ADRIAN STEEL COMPANY
906 JAMES STREET, ADRIAN, MI 49221

REVISION LEVEL

A

MAT'L USED:

DESIGNED BY: **PEN**

DESCRIPTION:

B/U ALM, WHITE NOISE TR

WEIGHT (Lbs.): **2**

SEGMENT CODE: **ELE**

PART NUMBER: **61501**

PURCHASED COMPONENT KEY FEATURES

DESCRIPTION OF REQUIREMENTS

DIMENSIONAL REQUIREMENTS (AS SHOWN ON DRAWING)

N/A

LOAD/RATING REQUIREMENT

N/A

MATERIAL REQUIREMENT

N/A

PACKAGING REQUIREMENT

N/A

OTHER REQUIREMENTS

Plug & play harness, does not include alarm.

2020 MDY
XL trim level required



THIS DRAWING IS THE PROPERTY OF ADRIAN STEEL COMPANY AND IS NOT TO BE USED IN ANY MANNER DETRIMENTAL TO THE INTERESTS OF ADRIAN STEEL COMPANY

TOLERANCES & INSPECTION

UNLESS OTHERWISE SPECIFIED

ALL BEND ANGLES ARE 90 DEGREES

ALL DIMENSIONS ARE IN INCHES.

REFERENCE DIMENSIONS (X.XXX)
DO NOT REQUIRE INSPECTION

FEATURES	HOLES/SLOTS	ANGLES
0.0 = ± .125	0.0 = ± .062	0° = ± 2°
0.00 = ± .062	0.00 = ± .031	0.0° = ± 1°
0.000 = ± .031	0.000 = ± .015	

Material Thickness: per ASTM Std.
Weld Callouts per AWS

RELEASE & REVISIONS

INITIAL ECN: **24579**

CURRENT ECN: **25280**

ECN DESCRIPTION:

Scan supplier's print

REVISED BY: **AMB**

PURCHASED COMPONENT

REFERENCED SUPPLIER AND/OR MANUFACTURER

AAMP

REFERENCED SUPPLIER AND/OR MANUFACTURER PART NUMBER

P-BUA-RANGER

COLOR (ONLY LIST IF COLOR SPECIFIC)

COMODITY ITEM (Y/N) (YES = ALL DIMENSIONS AND NOTES ARE REFERENCE)
(NOTE: DIMENSIONS AND FEATURES MAY VARY FOR A COMODITY ITEM.)

YES

PRINTED DOCUMENT IS UNCONTROLLED

Sheet 1 of 1

PART / PRODUCT IDENTIFICATION



ADRIAN STEEL®

ADRIAN STEEL COMPANY
906 JAMES STREET, ADRIAN, MI 49221

REVISION LEVEL

A

MAT'L USED:

DESIGNED BY: **A. BUSSING**

DESCRIPTION:

HARN, BUA RA

WEIGHT (Lbs.): **1.0**

SEGMENT CODE: **ALA**

PART NUMBER: **64014**

Revisions

Rev.	Date	Author	Description
1	10/6/2020	Bennet Fisher	Initial Drawing

Coverings

Id	Assembly
[34]	
[35]	

From	To	Color	Gauge
C1.1	S2	Black	16 AWG
C1.2	C2.2	Yellow	16 AWG
C1.3	C2.3	Blue	16 AWG
C1.4	S1	Green	16 AWG
C1.5	C2.5	Orange	16 AWG

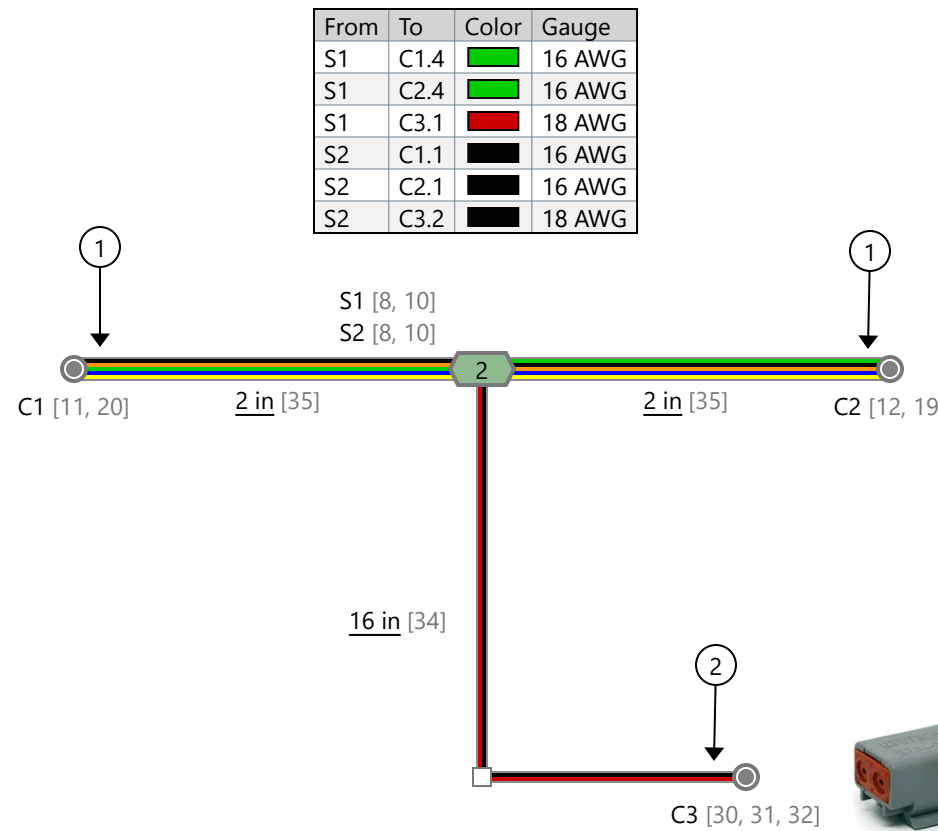

From	To	Color	Gauge
S1	C1.4	Green	16 AWG
S1	C2.4	Green	16 AWG
S1	C3.1	Red	18 AWG
S2	C1.1	Black	16 AWG
S2	C2.1	Black	16 AWG
S2	C3.2	Black	18 AWG

From	To	Color	Gauge
C2.1	S2	Black	16 AWG
C2.2	C1.2	Yellow	16 AWG
C2.3	C1.3	Blue	16 AWG
C2.4	S1	Green	16 AWG
C2.5	C1.5	Orange	16 AWG

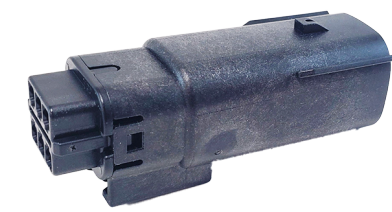

From	To	Color	Gauge
C3.1	S1	Red	18 AWG
C3.2	S2	Black	18 AWG



Notes

- ① Cover wiring with cloth tape; leave 1/2" of exposed wiring behind connector
- ② Lock tape split loom behind C3

Title	----	Part Number	P-BUA-RANGER_	
Description	2020 Ford Ranger - No Bliss/with Incandescent Backup Alarm Harness		Revision	----

	Name	Date
Drawn By	----	----
Eng Approved	----	----
Mfg Approved	----	----
QA	----	----



This document contains confidential and proprietary information that cannot be reproduced or divulged, in whole or in part, without written authorization.

“Compare Installation Instructions that come with the Product to Installation Instructions in ASCO System for accuracy.”



P-BUA-RANGER

Wiring Harness for Backup Alarm 2019-2021 Ford Ranger

INSTALLATION MANUAL





Thank you for purchasing the
P-BUA-RANGER



Table of Contents

Page 3 - Tools Required For Installation

WHAT'S INCLUDED:

- **Vehicle Specific Wire Harness (P-BUA-RANGER)**

COMPATIBLE ACCESSORIES:

- **97dB Backup Alarm (BUA-97C)**
- **97dB White Noise Backup Alarm (BUA-97WNC)**



TOOLS REQUIRED:



1.

2.

3.

1. 10mm Nut-setter
2. Impact Drill
3. Diagonal Cutters



STEP 1:

Locate the OEM tail lamp connector that is on the outside of the driver side frame rail



STEP 2:

Unplug the OEM connector and install the P-BUA-RANGER harness between the OEM connectors



STEP 3:

Route the harness over the top side of the frame rail, toward the center of the truck



STEP 4:

Use an impact drill and 10mm nut-setter to install a compatible backup alarm on the underside of the vehicle

Note: (2) 10mm TEK screws are provided with the compatible backup alarm



STEP 5:

Plug the backup alarm connector into the mating connector on the P-BUA-RANGER harness. Secure any excess wiring with cable ties. Use diagonal cutters to remove excess cable tie material.

STEP 6:

Test the backup alarm





Phone – 866-766-2267

E-Mail – support@aampglobal.com



EchoMaster is a Power Brand of AAMP Global

EchoMaster.com

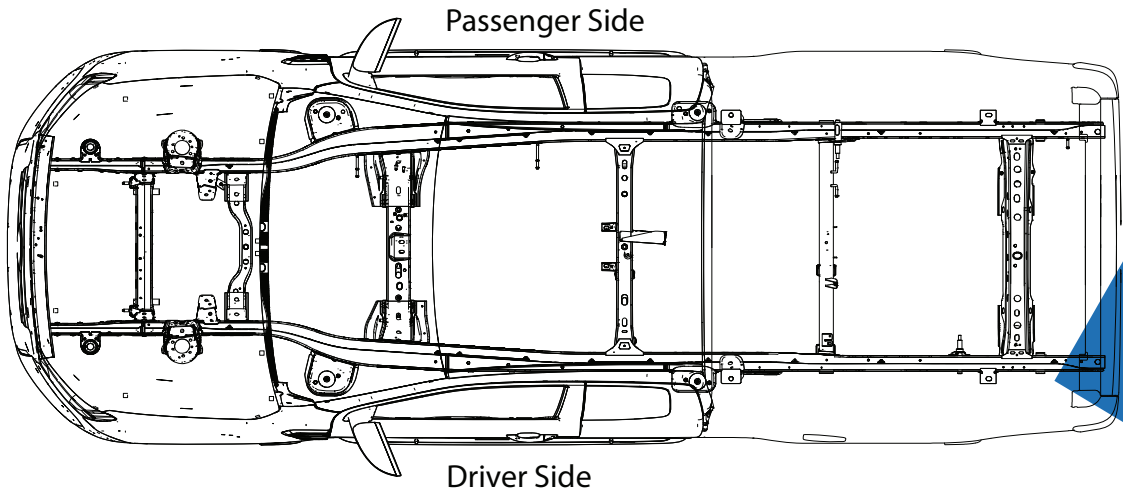

Inline connector is located on outside of driver side frame rail near rear of vehicle

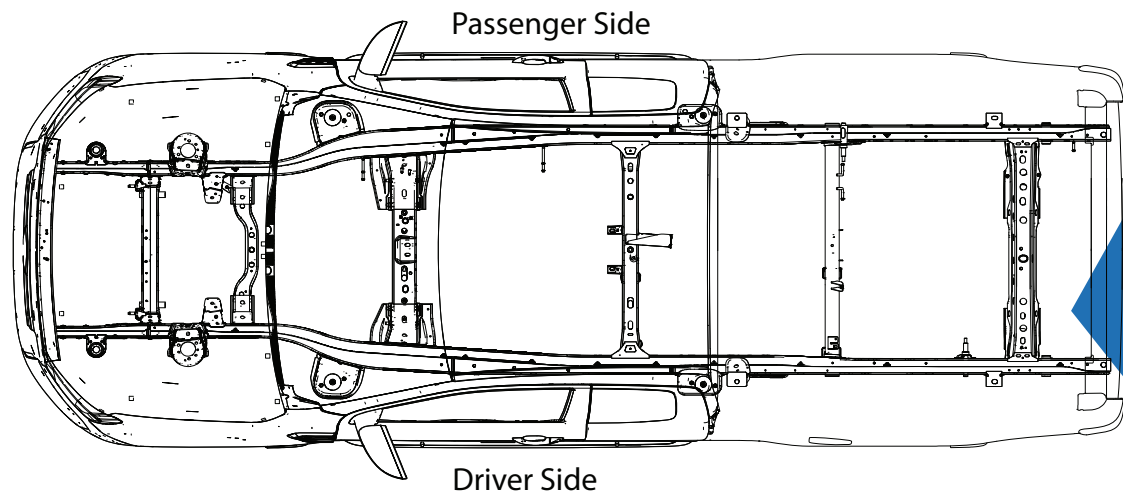

Backup alarm is located inside of driver side frame rail