

Introduction / Comments:

1.5kW & 2kW Inverter Kit for Ford Transit

Please Note:

1. Read all instructions prior to installation. Review the Adrian Steel **GENERAL PRECAUTIONS PAGES (56638)** before attempting installation. Only personnel familiar with using electrical best practices should perform this install. Reference **ELECTRICAL BEST PRACTICES MANUAL (54479)** before attempting installation.
2. Review order drawings to determine inverter placement.
3. Also if any power strip kits will need to be installed also and their placement.
4. Not all applications will use all the components listed.
5. **These instructions cover Transit with one or two Chassis Batteries (1CB or 2CB) & 1 and 2 Auxiliary (AUX) Batteries.**

For All Ford Transits



1500W



2000W



[66707]

1.5kW & 2kW Inverter Kit for Ford Transit



Section 1: Table of Contents

Table of Contents: [1.5kW & 2kW Inverter Kit for Ford Transit]

Page 1:	Cover Page/Introduction	1	
Section 1:	TOC & Safety Precautions Information	2	
Section 2:	Cable Kit Part Identification	4	
Section 3:	Tools Needed & Fastener ID/Torque Table	12	
Section 4:	General Vehicle Layout	15	
Section 5:	General Wiring Diagrams		
	• Two AUX Batteries + Contactor [KIT 66007]	20	
	• One AUX Battery + Timer [Kit ±66221]	20	
	• One AUX Battery + 67C Option [Kit *62046]	21	
	• Two AUX Battery + 67C Option [Kit 60331]	21	
	• Auxiliary Fuse Locations	22	
Section 6:	Chassis Battery Wiring		
	• Chassis Battery (CB) Access	24	
	• 6A: Single Chassis Battery (1CB) CABLE Routing [KITS 66007 and ±66221]	25	1CB
	• 6B: Two Chassis Battery (2CB) CABLE Routing [KIT *62046 and 60331]	31	2CB
Section 7:	Vehicle Integration		
	• 7A: Vehicle Interface For Non-67C Application (No upfitter switches)		
	• Locating the Remote Switch	32	N-67C
	• Remote Switch Harness Layout [KIT 66007]	33	
	• Remote Switch Harness Layout [KIT ±66221]	35	
	• Switch Installation	37	
	• Remote Wiring Routing	40	
	• 7B: Vehicle Interface For 67C Application (*62046 and 60331)		67C
	• Accessing 43-Way Vehicle Connector	45	
	• Connecting to 43-Way Upfitter Connector	47	
	• 67C Remote Wire Routing	51	
Section 8:	Sales Order Drawing Discussion	54	
Section 9:	Install/mount Contactor + Fuse Holders		
	• 9A: Contactor/Voltage Controller [KIT 66007]	55	
	• 9B: Fuse Holders [KIT ±66221 & *62046]	63	
Section 10:	Install/mount AUX batteries		
	• Plus Nuts Mounting	66	
Section 11:	Wire CABLE Routing CB to AUX batteries		
	• 11A: Routing from CB to 2 AUX Batteries (KIT 66007 & 60331)	71	2 AUX
	• 11B: Routing from CB to 1 AUX Battery (KITS ±66221 & *62046)	77	1 AUX
Section 12:	Inverter Installation		
	• Wire and Cabling	80	
	• Partition/Bracket	84	
Section 13:	Fuse Installation	85	
Section 14:	Important Labeling		
	• Remote switch labels (Yellow)	87	
	• Power switch notice label (Blue)	87	
	• Caution labels/ battery tags	88	
Section 15:	Test and Check	89	
Section 16:	Appendices		
	A. FLEET Requested docs (Schematics, tools, Torque table)	91	
	B. Plusnut Installation Guide	97	

Section 1: Table of Contents







These symbols are used in the document to warn installer to make sure there is understanding beyond general precautions used when working on electrical installations.

	ANSI Z535.6-2006 refers to the use of blue when “addresses practices not related to personal injury”.
	Yellow labelling level of personal injury = could result in minor injury.
	Red labelling level of personal injury = could/ will result in death

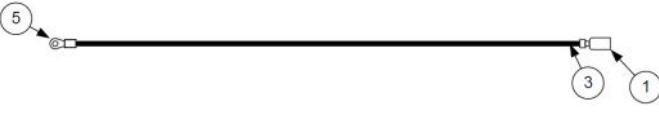

Section 2: Cable Kit Part Identification [KIT 66007: 2-3kW] :

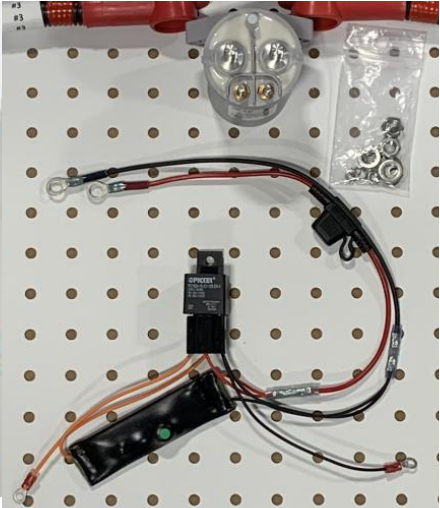
Part Description & Label	Part Photo/Diagram
<p>Kit PPDS Photo [Example: 66007: 2-3kW (1CB/CONT/2AUX)]:</p> <ul style="list-style-type: none"> • Harness wires #1-#13, 250,250,400 • Fuses, • Fuse holders, • Fuse holder Bracket, • Switch Harness Kit • Misc. Wire ties and fasteners • Contactor & VSS-VC Harness 	
<p>OEM Battery POSITIVE to FUSE, “WIRE #1”- 32”, RED, Black Corrugate, POSITIVE</p>	<p>WIRE #1</p>
<p>FUSE to CONTACTOR, “WIRE #2”- 62”, RED, Black Corrugate, POSITIVE</p>	<p>WIRE #2</p>
<p>CONTACTOR to AUX FUSE, “WIRE #3”- 10”, RED, Black Corrugate, POSITIVE</p>	<p>WIRE #3</p>
<p>AUX FUSE to AUX 1 Battery POSITIVE & AUX 1 Battery POSITIVE to INVERTER, FUSE “WIRE #4”- 30”, RED, Black Corru- gate, POSITIVE</p>	<p>WIRE #4 Two PCS</p>
<p>AUX 1 Battery POSITIVE to AUX 2 Battery POSITIVE, “WIRE #5”- 40” RED wire, Black Corrugate, POSITIVE</p>	<p>WIRE #5</p>
<p>INVERTER FUSE to INVERTER, “WIRE #6”- 56”, RED, Black Corrugate, POSITIVE</p>	<p>WIRE #6</p>
<p>OEM Battery NEGATIVE cable to AUX 1 Battery NEGATIVE, “WIRE #7”- 102”, BLACK, Black Corrugate, NEGATIVE</p>	<p>WIRE #7</p>
<p>AUX 1 Battery NEGATIVE to AUX 2 Battery NEGATIVE, “WIRE #8”- 30” BLACK wire, Black Corru- gate, NEGATIVE</p>	<p>WIRE #8</p>
<p>AUX 2 Battery NEGATIVE to INVERTER, “WIRE #9”- 74”, BLACK, Black Corrugate, NEGATIVE</p>	<p>WIRE #9</p>
<p>INVERTER GROUNDING WIRE to Chassis, “WIRE #10”- 40”, GREEN wire, GROUND</p>	<p>WIRE #10</p>

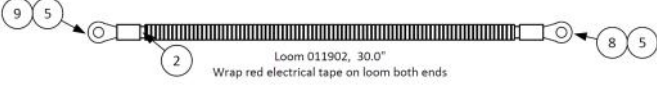
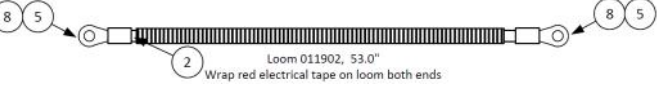
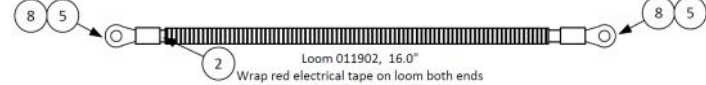
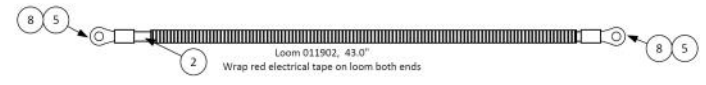

Section 2: Cable Kit Part Identification [66007: 2-3kW Continued]:

Part Description & Label	Part Photo/Diagram
<p>Kit PPDS Photo [Example: 66007: 2-3kW (1CB/CONT/2AUX)]: Remote SW [Example: D019620]:</p> <ul style="list-style-type: none"> • QTY 5, #013131 CABLE TY • QTY 1, #D015694 SWITCH LABEL • QTY 1, #D020124 JUMPSTART LABEL • QTY 1, #015674 SWITCH • QTY 1, #017591 5A MICRO FUSE 	
<p>ADD-A-FUSE WIRE to SWITCH, “WIRE #11”- RED wire, Black Corrugate, HAAT</p>	<p>WIRE #11</p> 
<p>GROUND WIRE to SWITCH, “WIRE #12” - BLACK wire, GROUND</p>	<p>WIRE #12</p> 
<p>SWITCH to INVERTER, “WIRE #13” - ORANGE wire, Black Corrugate, Remote Signal</p>	<p>WIRE #13</p> 
<p>VSS-VC Harness [Preassembled] and CONTACTOR with Terminal covers</p>	
<p>Vanner Remote Switch (Red Rocker Switch)</p>	

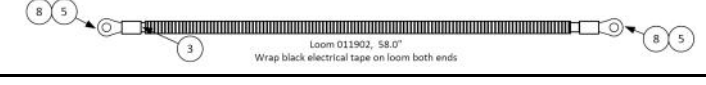
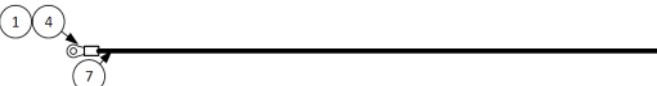

Section 2: Cable Kit Part Identification [KIT 66221: 1.5kW]:

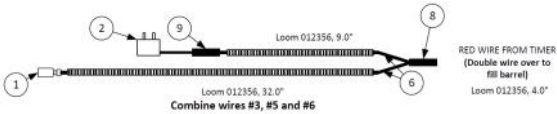
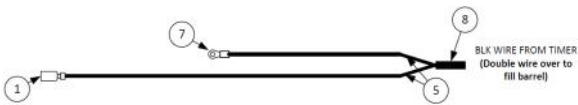
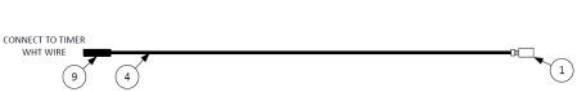
Part Description & Label	Part Photo/Diagram
Kit [Example: 66221 : 1.5kW (1CB/1AUX)] PPDS Photo 250,250,200 <ul style="list-style-type: none"> • Harness wires #1-#7+, • Fuses, • Fuse holders, • Fuse holder Bracket, • Switch Harness Kit • Misc. Wire ties and fasteners • Contactor & VSS-VC Harness 	
OEM Battery POSITIVE to CB FUSE, " WIRE #1 "- 32", RED, Black Corrugate, POSITIVE	WIRE #1  Loom 011902, 30.0" Wrap red electrical tape on loom both ends
CB FUSE to AUX FUSE, " WIRE #2 "- 55", RED, Black Corrugate, POSITIVE	WIRE #2  Loom 011902, 53.0" Wrap red electrical tape on loom both ends
AUX FUSE to AUX 1 Battery POSITIVE & AUX 1 Battery POSITIVE, " WIRE #3 "- 18", RED, Black Corrugate, POSITIVE **Two PIECES**	WIRE #3 Two PCS  Loom 011902, 16.0" Wrap red electrical tape on loom both ends
INV FUSE to INVERTER " WIRE #4 "- 45", RED, Black Corrugate, POSITIVE	WIRE #4  Loom 011902, 43.0" Wrap red electrical tape on loom both ends
OEM Battery NEGATIVE cable to AUX 1 Battery NEGATIVE, " WIRE #5 "- 76", BLACK, Black Corrugate, NEGATIVE	WIRE #5  Loom 011902, 74.0" Wrap black electrical tape on loom both ends
AUX 1 Battery NEGATIVE to INVERTER, " WIRE #6 "- 60", BLACK, Black Corrugate, NEGATIVE	WIRE #6  Loom 011902, 58.0" Wrap black electrical tape on loom both ends
INVERTER GROUNDING WIRE to Chassis, " WIRE #7 "- 24", GREEN wire, GROUND	WIRE #7 

Section 2: Cable Kit Part Identification [KIT 66221: 1.5kW Continued]:

Part Description & Label	Part Photo/Diagram
Kit [Example: 66221 : 1.5kW]: PPDS Remote SW Photo [Example: D919531]: <ul style="list-style-type: none"> • QTY 3, #D018361 FUSE HOLDER • QTY 1, #D018595 TVM/SW • QTY 1, #D016967 FUSE PLATE • QTY 5, #013131 CABLE TY • QTY 1, BAG 02423 	
ADD-A-FUSE WIRE to SWITCH and TIMER, “WIRE #8” - RED wire, Black Corrugate, HAAT	WIRE #8 
GROUND WIRE to SWITCH and TIMER, “WIRE # 9” - BLACK wire, GROUND	WIRE #9 
REMOTE SWITCH to TIMER “WIRE # 10” - WHITE wire, Black Corrugate, Switch Signal	WIRE #10 
TIMER to INVERTER “WIRE # 11” - OR- ANGE wire, Black Corrugate, Remote Signal	WIRE #11 
Vanner Remote Switch and Timing circuit in- cluded in the kit above	

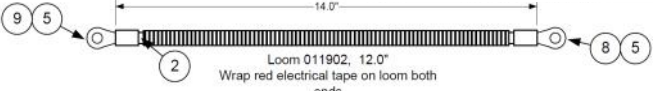
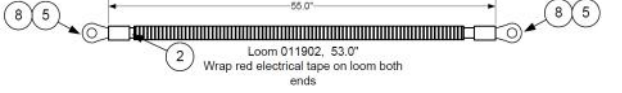
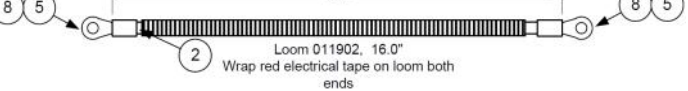
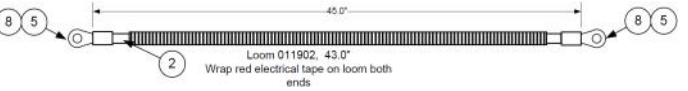

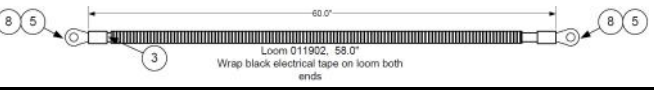
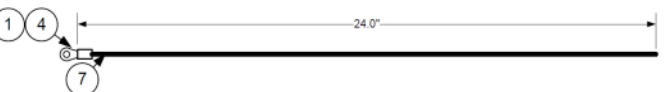



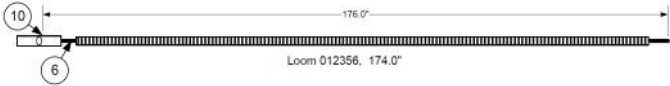

Section 2: Cable Kit Part Identification [KIT *62046: 1.5kW-67C]:

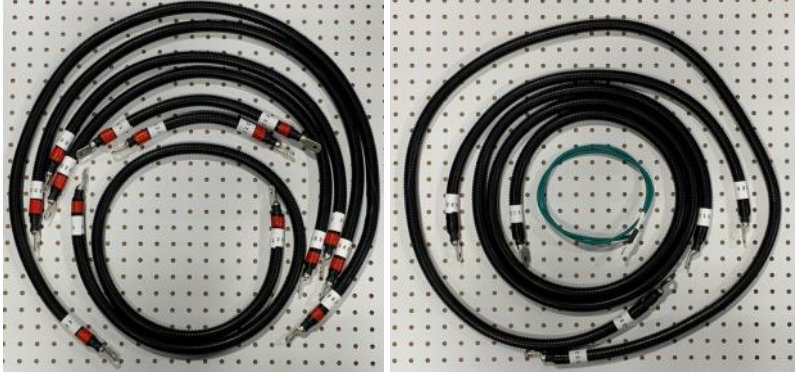
Part Description & Label	Part Photo/Diagram
Kit [Example: 62046: 1.5kW (2CB/1AUX)] PPDS Photo 250,250,200 <ul style="list-style-type: none"> • Harness wires #1-#7+, • Fuses, • Fuse holders, • Fuse holder Bracket, • Misc. Wire ties and fasteners 	
OEM Battery POSITIVE to CB FUSE, “WIRE #1” - 32”, RED, Black Corrugate, POSITIVE	WIRE #1 
CB FUSE to AUX FUSE, “WIRE #2” - 55”, RED, Black Corrugate, POSITIVE	WIRE #2 
AUX FUSE to AUX 1 Battery POSITIVE & Battery POSITIVE to INV FUSE, “WIRE #3” - 18”, RED, Black Corrugate, POSITIVE **Two PIECES**	WIRE #3 Two PCS 
INV FUSE to INVERTER “WIRE #4” - 45”, RED, Black Corrugate, POSITIVE	WIRE #4 
OEM Battery NEGATIVE to AUX 1 Battery NEGATIVE, “WIRE #5” - 76”, BLACK, Black Corrugate, NEGATIVE	WIRE #5 
AUX 1 Battery NEGATIVE to INVERTER, “WIRE #6” - 60”, BLACK, Black Corrugate, NEGATIVE	WIRE #6 
INVERTER GROUNDING WIRE to Chassis, “WIRE #7” - 24”, GREEN wire, GROUND	WIRE #7 

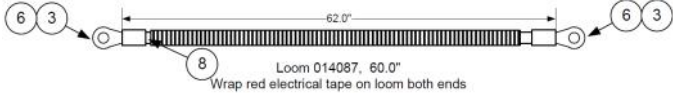

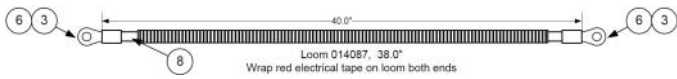
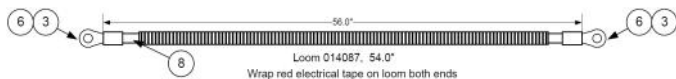

Section 2: Cable Kit Part Identification [KIT *62046: 1.5kW-67C Continued]:

Part Description & Label	Part Photo/Diagram
Kit [Example: 62046 : 1.5kW]: PPDS Remote SW Photo [Example: D919744]: <ul style="list-style-type: none"> • QTY 3, #D018361 FUSE HOLDER • QTY 1, #D016967 FUSE PLATE • QTY 5, #013131 CABLE TY • QTY 1, BAG 02423 	
Remote SWITCH to INVERTER, " WIRE #8 " - 176", ORANGE wire	

Section 2: Cable Kit Part Identification [KIT 60331: 2kW-67C] :

Part Description & Label	Part Photo/Diagram
<p>Kit PPDS Photo [Example: 60331: 2kW (2CB/CONT/2AUX)]:</p> <ul style="list-style-type: none"> • Harness wires #1-#11, • Fuses, 250,250,400 • Fuse holders, • Fuse holder Bracket, • Switch Harness Kit • Misc. Wire ties and fasteners • Contactor & VSS-VC Harness 	
<p>OEM Battery POSITIVE to FUSE, “WIRE #1”- 14”, RED, Black Corrugate, POSITIVE</p>	<p>WIRE #1</p> 
<p>FUSE to CONTACTOR, “WIRE #2”- 62”, RED, Black Corrugate, POSITIVE</p>	<p>WIRE #2</p> 
<p>CONTACTOR to AUX FUSE, “WIRE #3”- 10”, RED, Black Corrugate, POSITIVE</p>	<p>WIRE #3</p> 
<p>AUX FUSE to AUX 1 Battery POSITIVE & AUX 1 Battery POSITIVE to INVERTER, FUSE “WIRE #4”- 30”, RED, Black Corru- gate, POSITIVE</p>	<p>WIRE #4 Two PCS</p> 
<p>AUX 1 Battery POSITIVE to AUX 2 Battery POSITIVE, “WIRE #5”- 40” RED wire, Black Corrugate, POSITIVE</p>	<p>WIRE #5</p> 
<p>INVERTER FUSE to INVERTER, “WIRE #6”- 56”, RED, Black Corrugate, POSITIVE</p>	<p>WIRE #6</p> 
<p>OEM Battery NEGATIVE cable to AUX 1 Battery NEGATIVE, “WIRE #7”- 102”, BLACK, Black Corrugate, NEGATIVE</p>	<p>WIRE #7</p> 
<p>AUX 1 Battery NEGATIVE to AUX 2 Battery NEGATIVE, “WIRE #8”- 30” BLACK wire, Black Corru- gate, NEGATIVE</p>	<p>WIRE #8</p> 
<p>AUX 2 Battery NEGATIVE to INVERTER, “WIRE #9”- 74”, BLACK, Black Corrugate, NEGATIVE</p>	<p>WIRE #9</p> 
<p>INVERTER GROUNDING WIRE to Chassis, “WIRE #10”- 40”, GREEN wire, GROUND</p>	<p>WIRE #10</p> 

Section 2: Cable Kit Part Identification [60331: 2kW-67C Continued]:

Part Description & Label	Part Photo/Diagram
<p>Kit PPDS Photo [Example: 60331: 2kW (2CB/ CONT/2AUX)]: Remote SW [Example: D019620]:</p> <ul style="list-style-type: none"> • QTY 5, #013131 CABLE TY • QTY 1, #D015694 SWITCH LABEL • QTY 1, #D020124 JUMPSTART LABEL • QTY 1, #015674 SWITCH • QTY 1, #017591 5A MICRO FUSE 	
<p>Remote SWITCH to INVERTER, “WIRE #11” - 177”, ORANGE wire</p>	
<p>VSS-VC Harness [Preassembled] and CON-TACTOR with Terminal covers</p>	
<p>Vanner Remote Switch (Red Rocker Switch)</p>	

This kit also comes with rocker switch, so it has both Non-67C and 67C options

Section 3: Tools Needed & Fastener ID/Torque Table:



- 1) Insulated Splice Crimper
- 2) Wire Strippers
- 3) Diagonal Cutters
- 4) Plastic Trim Tool
- 5) Drill driver
- 6) Measuring tape
- 7) Phillips Bit with Bit holder
- 8) 3/4" Hole or Step Drill (Unibit)
- 9) Medium and Small (-) Screwdriver
- 10) Large #3 Phillips (+) Screwdriver
- 11) Sockets:
 - 8mm, 10mm, 13mm
 - 5/16", 3/8", 7/16", 1/2"
 - Socket driver and extensions
- 12) Torque Wrench [~8-20Nm range]
- 13) Tin Snips
- 14) #3 Philips (+) & Medium slotted torque socket
- 15) Marker [Not Shown]
- 16) Plusnut gun
- 17) Drill Bits:
 - 5/16", 3/8", 1/2"
 - 1 - 3/16" hole saw (if applicable)

Figure 3-1: Tools Needed for Installation

Section 3: Tools Needed & Fastener ID/Torque Table:

Torque Table:

ITEM NO.	ASC PN	Description	PCS	Torque Range	Use Wrench or Size
1	BAG0406-A	4" x 6" 3MIL AUTOBAG	1	--	
2	FAS0055	Nut, Hex Flange, Nylock 1/4-20	4	12Nm [+/- 1.8Nm] (106lb.in).	7/16"
3	FAS0018	SCREW, HH SFLNG 1/4-20X.62 ZP	4	12Nm [+/- 1.8Nm] (106lb.in).	7/16"
4	FAS0048	Screw, Button Hd Hex Soc, 5/16-18X2, ZN	8	15Nm [+/- 1.8Nm] (132lb.in).	3/8" Allen
5	FAS0025	Screw, Truss Hd. Ph, #10-24x0.50	4	3Nm [+/- 0.5Nm] (27lb.in).	#2 Phillips
6	FAS0029	NUT, HEX NLK 10-24 ZP	4	3Nm [+/- 0.5Nm] (27lb.in).	3/8"
7	FAS0159	NUT, HEX TPLK M6X1.0	2	8Nm [+/- 1.2Nm] (71lb.in).	10mm
8	FAS0091	Plusnut, 5/16	8	--	--
9	FAS0833	WASHER, CUP FLANGED 1.5"	8	--	--
10	03927-1	SPACER, FLR, 1010, 11/32 ZP	8	--	--
11	FAS0148	Screw, Self Drill/Tap, Pan Ph. Hd., #10x0.5, NI-ZN	1	3Nm [+/- 0.5Nm] (27lb.in).	#2 Phillips
12	FAS0360	SCREW, ST, THP 14-10X.75 SS	4	3Nm [+/- 0.5Nm] (27lb.in).	#2 Phillips
13	FAS0629	Screw, Self Drill/Tap, Wafer Ph. Hd., #10x1.5NI-ZN	2	3Nm [+/- 0.5Nm] (27lb.in).	#2 Phillips
14	FAS0032	Screw, Flat Phillips Hd, #10-24x1.0	2	3Nm [+/- 0.5Nm] (27lb.in).	#2 Phillips
15	FAS0020	Nut, Hex Flange, #10-24	2	3Nm [+/- 0.5Nm] (27lb.in).	3/8"

Figure 3-2: Fasteners included in Kit

Please **NOTE**: Certain fasteners or hardware may not be used for certain kits or installations.

BAG66631

Kit Installation Fasteners:

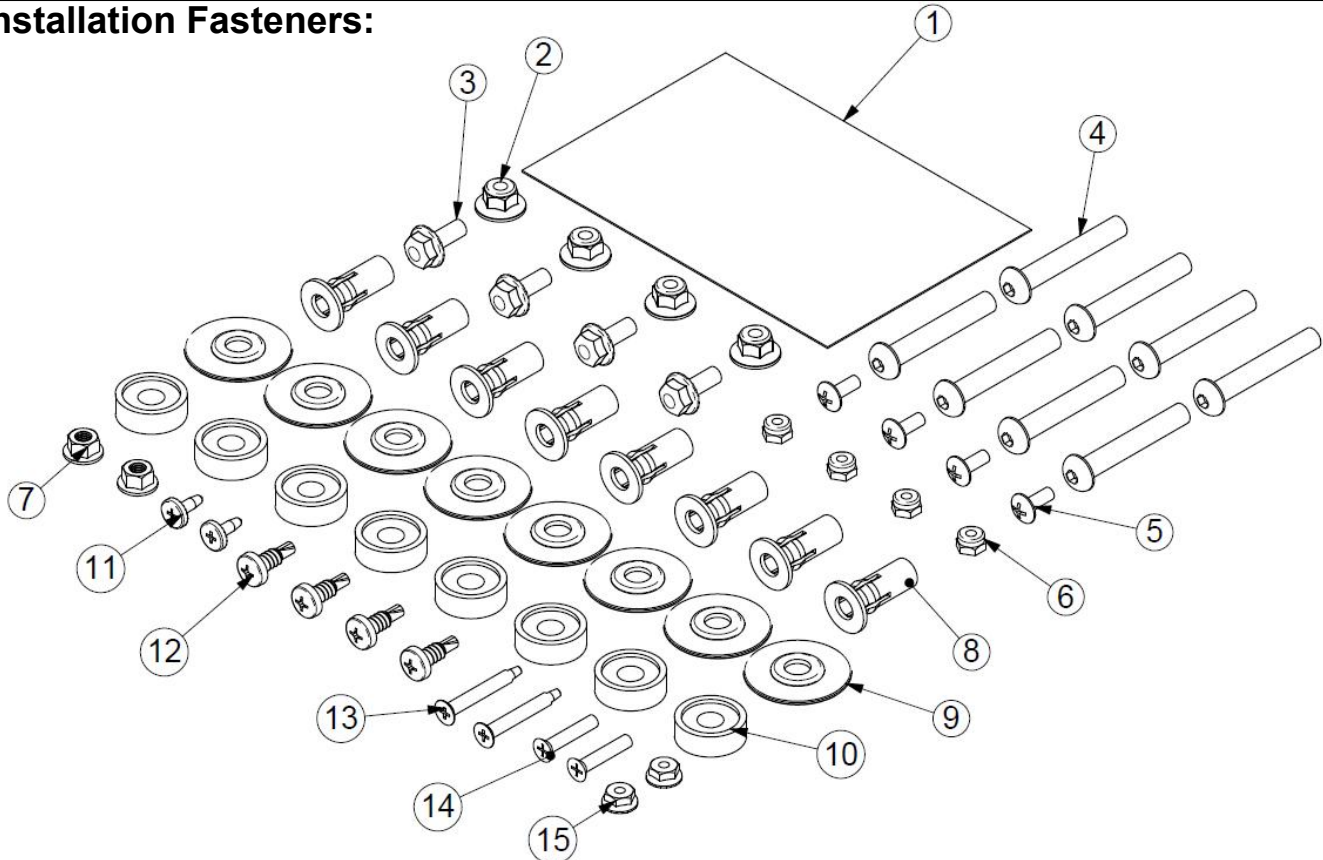

Figure 3-3: Fastener Diagram

Section 3: Tools Needed & Fastener ID/Torque Table:





Ref. NO.	ASC PN	Description	PCS	Torque Range	Use Wrench or Size
16		Positive Battery Terminal busbar 	1	8Nm [+/- 1.2Nm] (71 lb.in).	5/16"
17		Positive Battery Terminal busbar (used for 1 CB KITS 66007 & 66221) 	1	-Will USE FAS0159 will be 8Nm [+/- 1.2Nm] (71 lb.in).	—
18		Cables to VANNER Fuse Holder 	4	12Nm [+/- 1.8Nm] (106lb.in).	1/2"
19		Chassis Battery Fuse Holder to bracket nuts [KEPS] 	2	3Nm [+/- 0.5Nm] (27lb.in).	3/8"
20		Inverter +/- Terminals Phillips and slotted screws	Three (3) Positions	8Nm [+/- 1.2Nm] (71 b.in).	#3 Phillips and 1/4" Standard driver bits
21		Contactor Mains 	2	10.2Nm [+/- 1.1Nm] (~90 lb.in).	1/2"
22		Contactor coil 	2	2.5 Nm [+/- 0.9 Nm] (~22.5 lb.in).	3/8"
Other Fasteners in Vehicle					
23		CB Positive Battery Post Clamp —	1	8Nm [+/- 1.2Nm] (71 lb.in).	10mm Nut
24		CB Negative Battery Cable to Battery Clamp —	1	8Nm [+/- 1.2Nm] (71 lb.in).	13mm Nut
25		AUX positive and negative terminal fasteners —	2 or 4	8Nm [+/- 1.2Nm] (71 lb.in).	1/2" Nut
26		Fuse holder & Battery Hold Down T-Bracket —	2	10Nm [+/- 1.5Nm] (89 lb.in).	8mm OR 10mm Screw

Figure 3-4: Other Fasteners

Please NOTE: Certain fasteners or hardware may not be used for certain kits or installations.

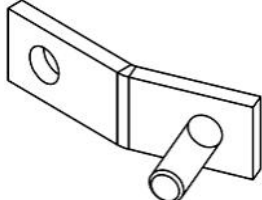
Section 4: General Vehicle Layout [Two AUX Batteries + Contactor (KIT 66007)]:

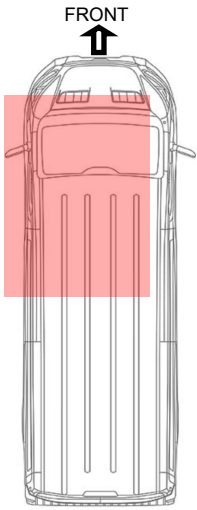

NOTE: New Fuse Box shape (on Pg.20) and fuse locations for MDY2026 and beyond.

*Position 32, F191, is 10A Ignition hot.
Position 8, F108, is Battery hot.*

- Use sales order drawing to place all equipment.
- Inverter can be located on either side of the partition.

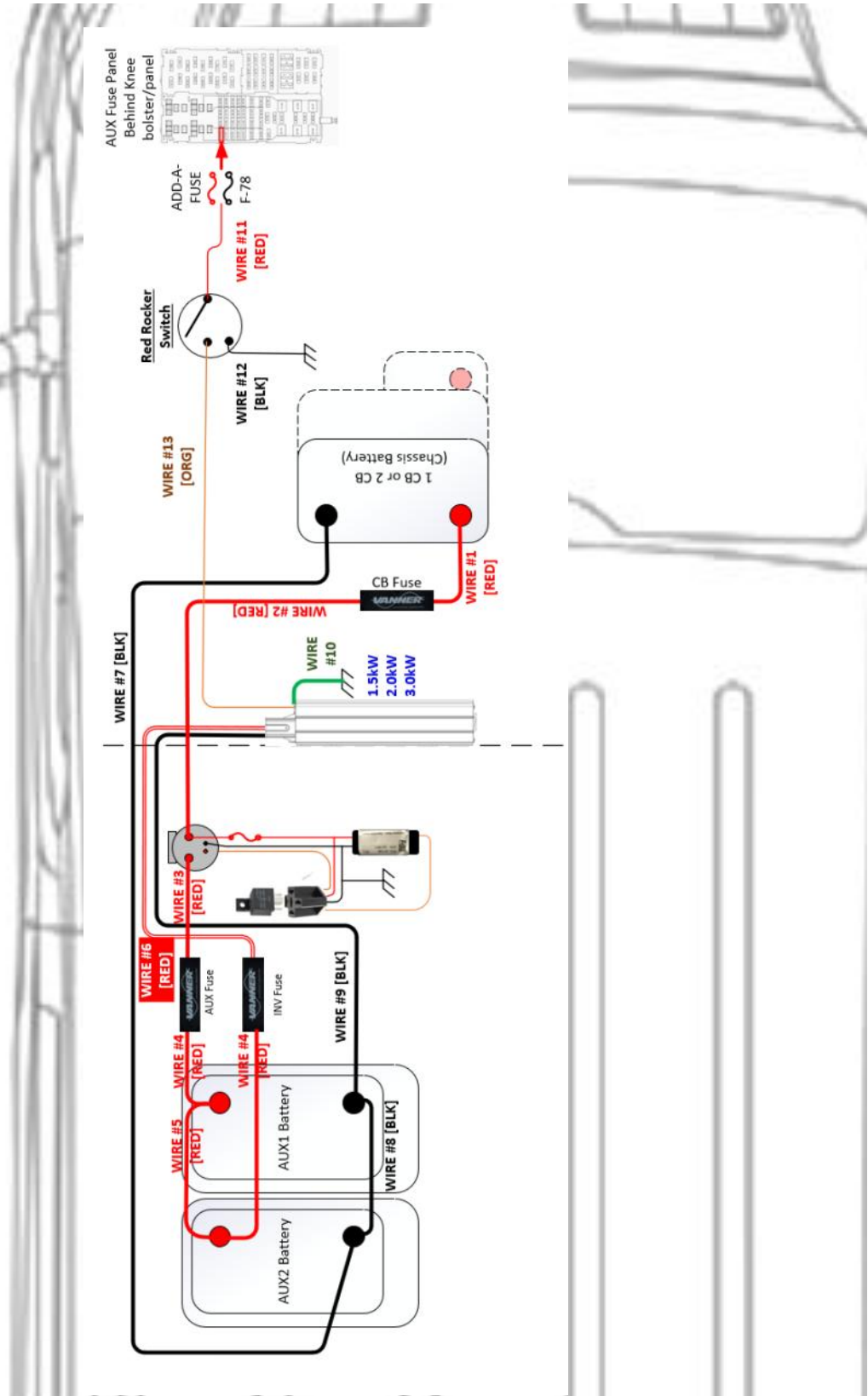
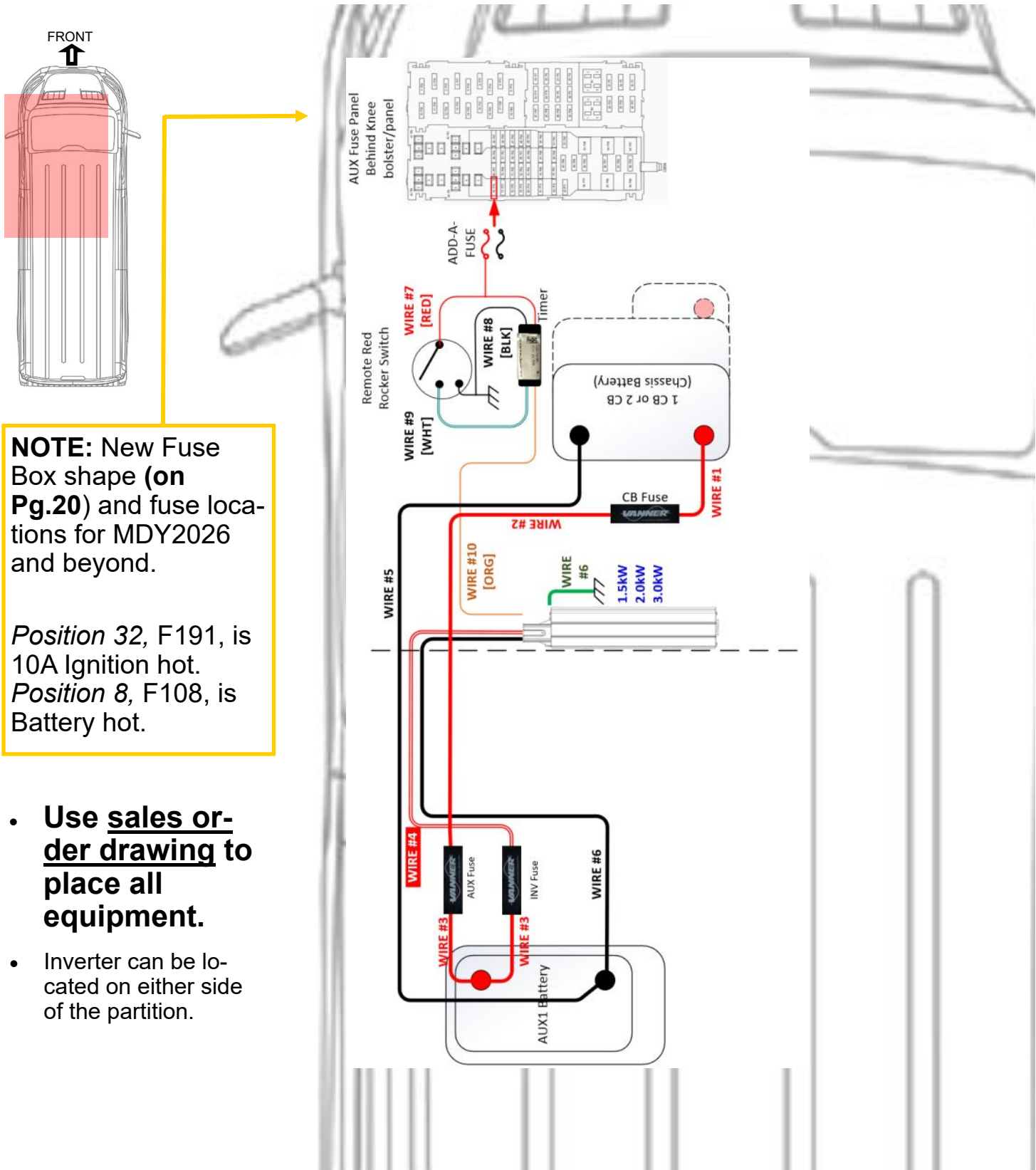

Figure 4-1: Transit NON-67C Diagram [Top]

Section 4: General Vehicle Layout [One AUX Battery + Timer (Kit 66221)]:



NOTE: New Fuse Box shape (on Pg.20) and fuse locations for MDY2026 and beyond.

Position 32, F191, is 10A Ignition hot.
Position 8, F108, is Battery hot.

- Use sales order drawing to place all equipment.
- Inverter can be located on either side of the partition.

Figure 4-2: Transit NON-67C Diagram [Top]

Section 4: General Vehicle Layout [One AUX Battery + 67C Option (Kit *62046)]:

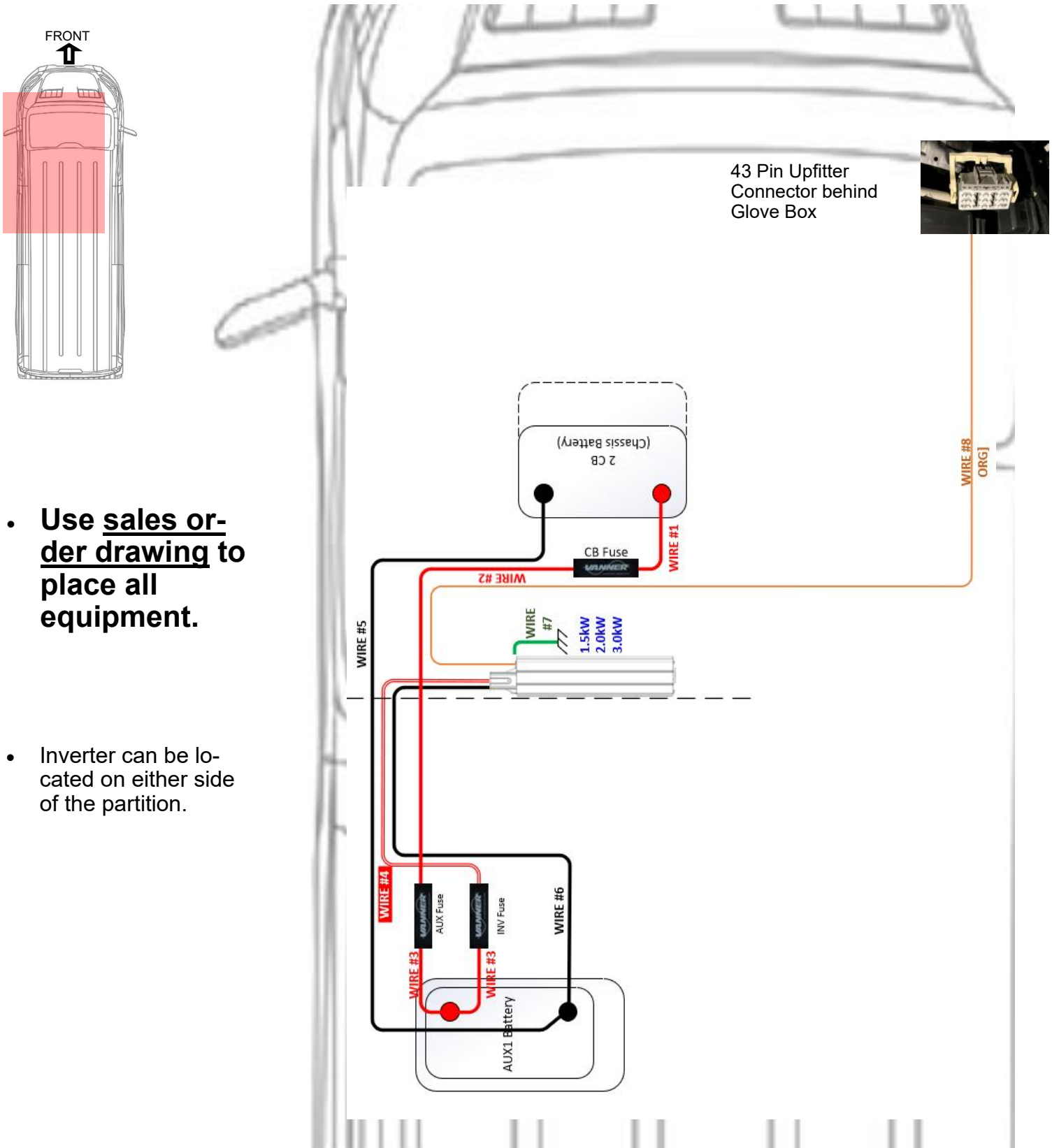

- **Use sales order drawing to place all equipment.**

- Inverter can be located on either side of the partition.

Figure 4-2: Transit NON-67C Diagram [Top]

Section 4: General Vehicle Layout [Two AUX Batteries + 67C + Contactor (KIT 60331)]:

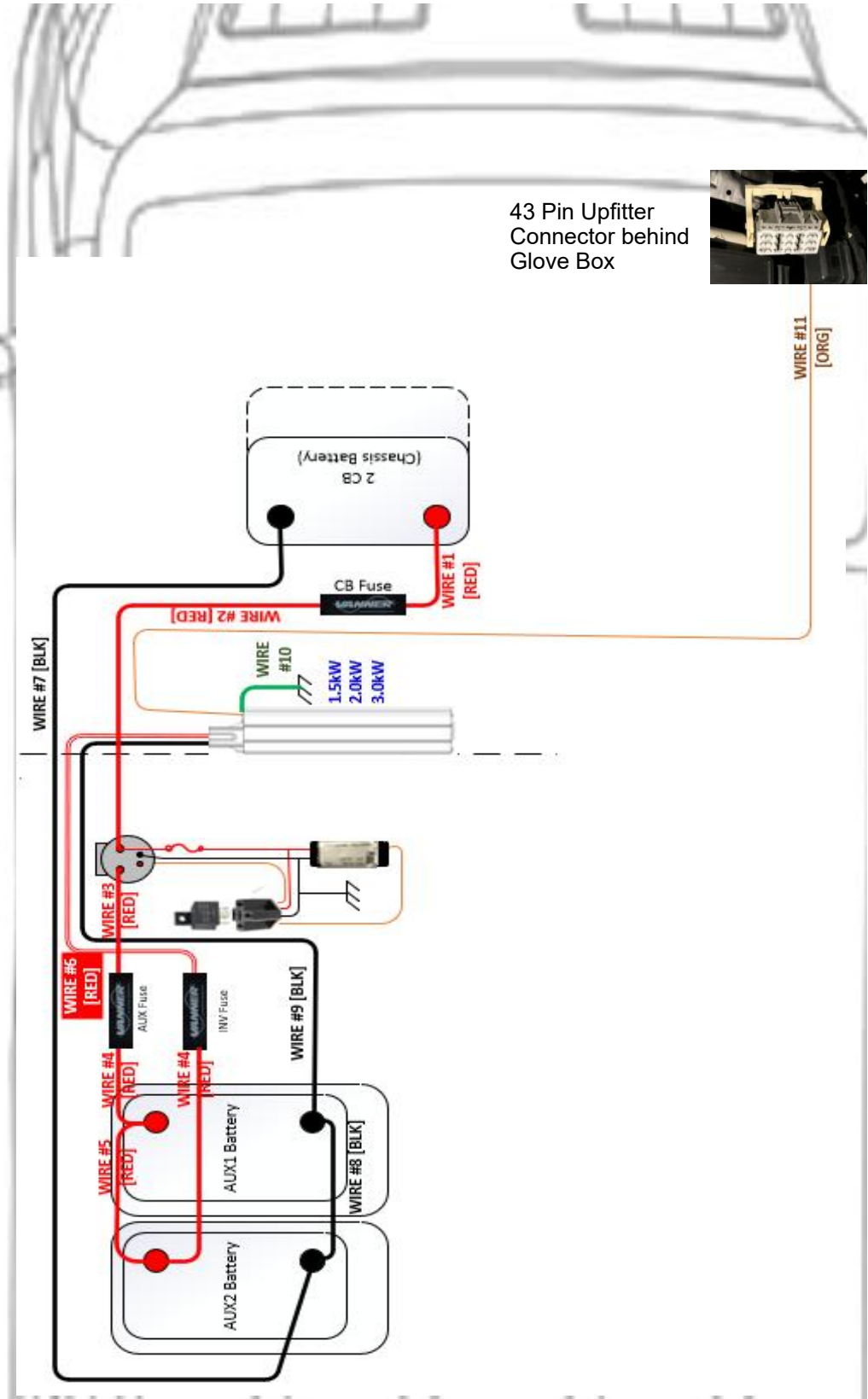
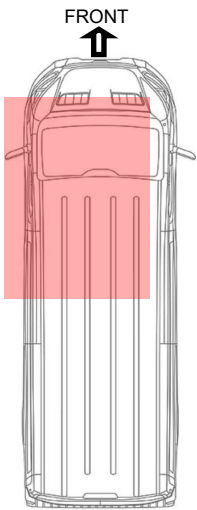

- Use sales order drawing to place all equipment.

- Inverter can be located on either side of the partition.

This kit also comes with rocker switch, so it has both Non-67C and 67C options

Figure 4-1: Transit NON-67C Diagram [Top]

Section 4: General Vehicle Layout [One & Two AUX Battery]:

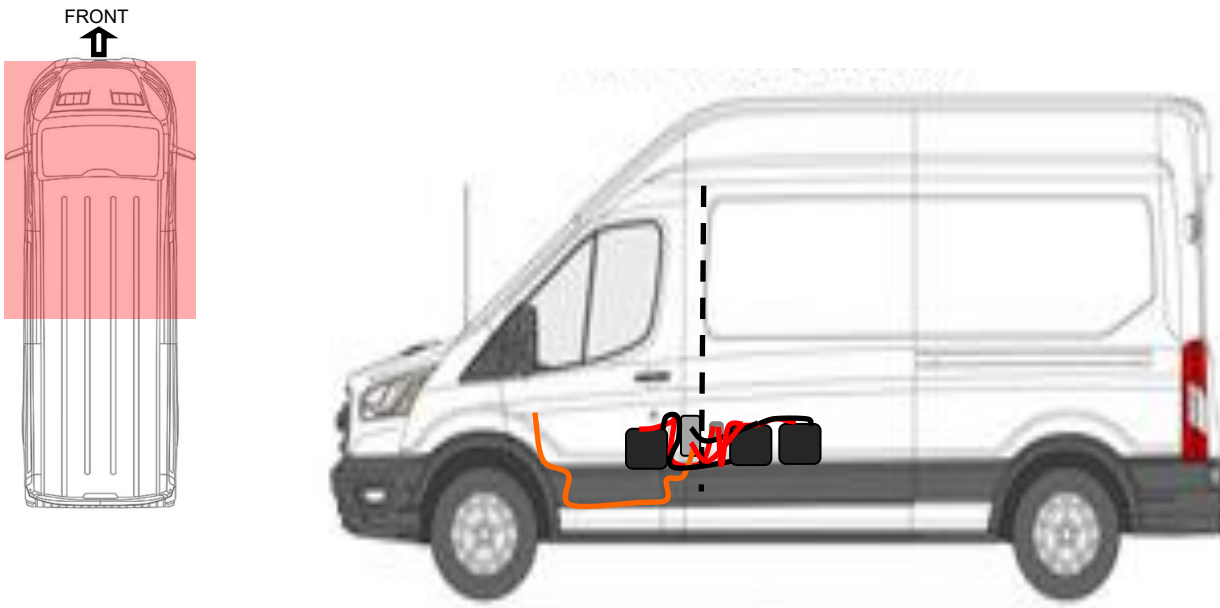

Figure 4-3: Transit Two AUX Battery Diagram

- **Use sales order drawing to place all equipment.**

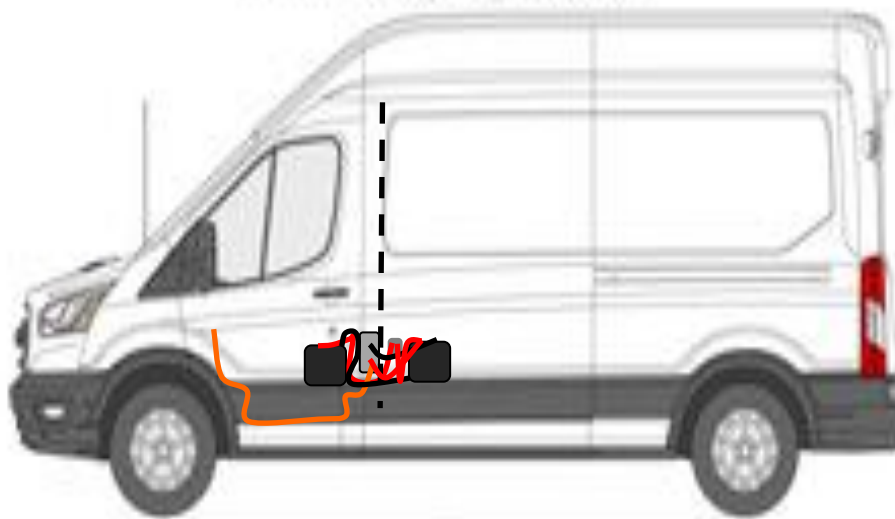
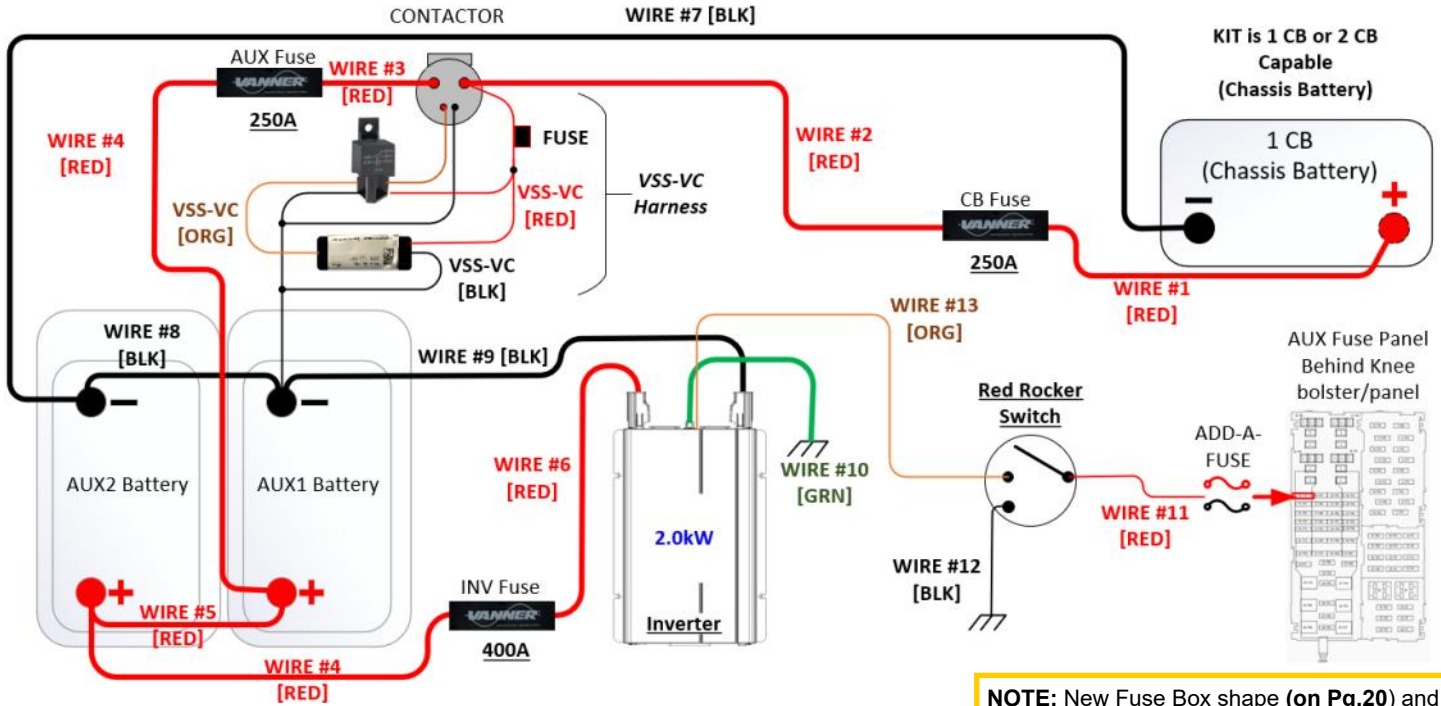

Figure 4-4: Transit One AUX Battery Electrical Diagram

Section 5: General Wiring Diagrams:

Two AUX Batteries + Contactor (KIT 66007)



NOTE: New Fuse Box shape (on Pg.20) and fuse locations for MDY2026 and beyond.

Figure 5-1: Complete Wiring Diagram for kit with a Contactor

One AUX Battery + Timer (Kit #66221) :

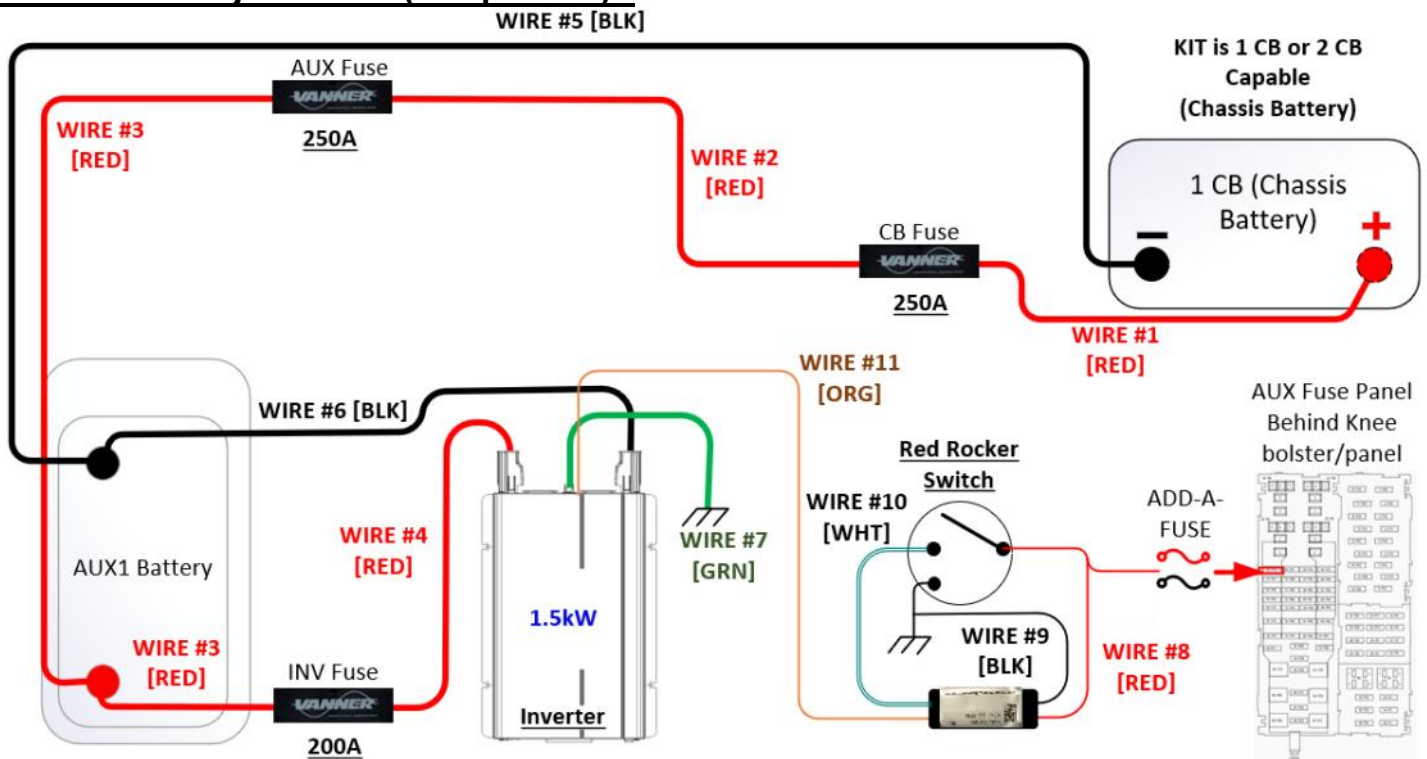

NOTE: New Fuse Box shape (on Pg.20) and fuse locations for MDY2026 and beyond.

Figure 5-2: Complete Wiring Diagram for kit with a timer switch

Section 5: General Wiring Diagrams:

One AUX Battery + 67C Option (Kit *62046)

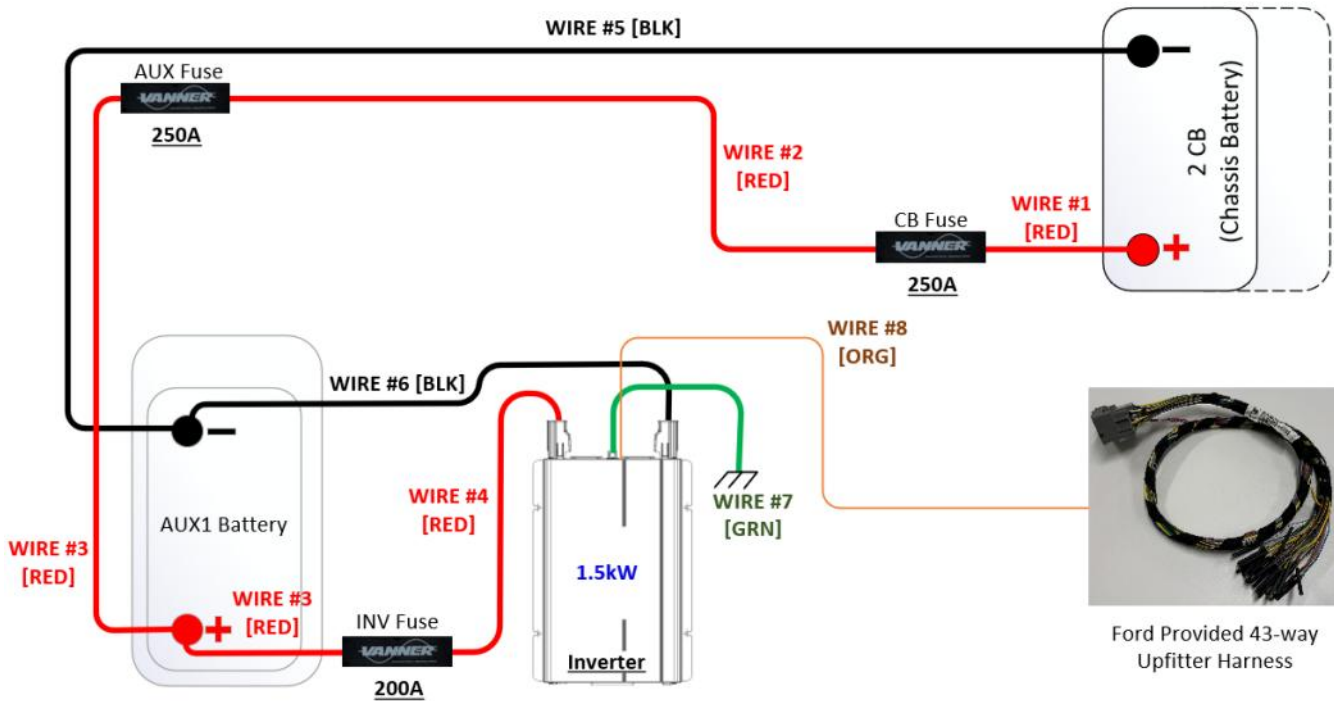
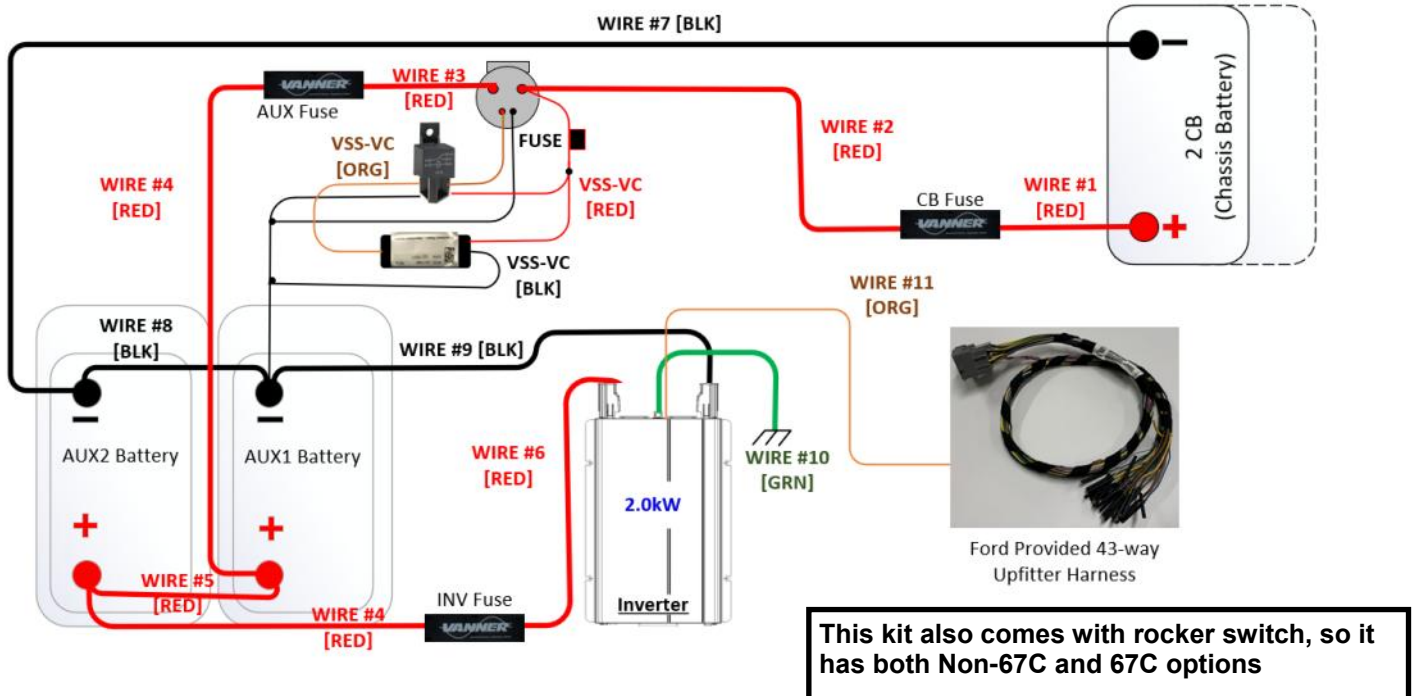

Figure 5-3: Complete Wiring Diagram for 67C Option Included

Two AUX Batteries + 67C (with Switch Option) + Contactor (Kit 60331)



This kit also comes with rocker switch, so it has both Non-67C and 67C options

Section 5: General Wiring Diagrams:

Fuse Panel: Add-A-Fuse location [KITS 66007 & 66221]

For Model Year 2026+ Fuse Panel Add-a-Fuse Location, see next page

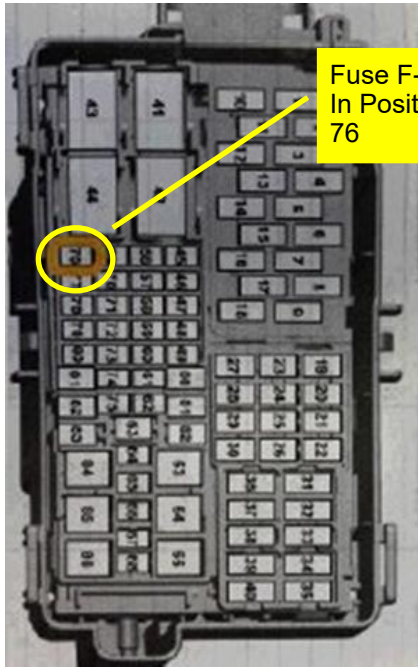
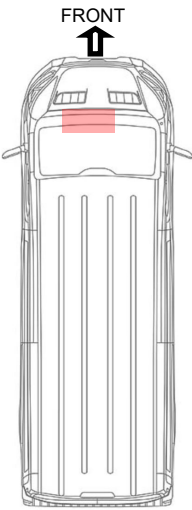

Fuse F-78, In Position 76

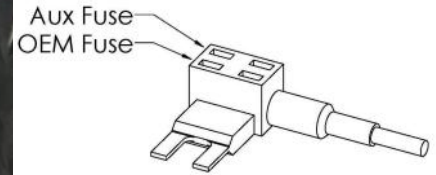
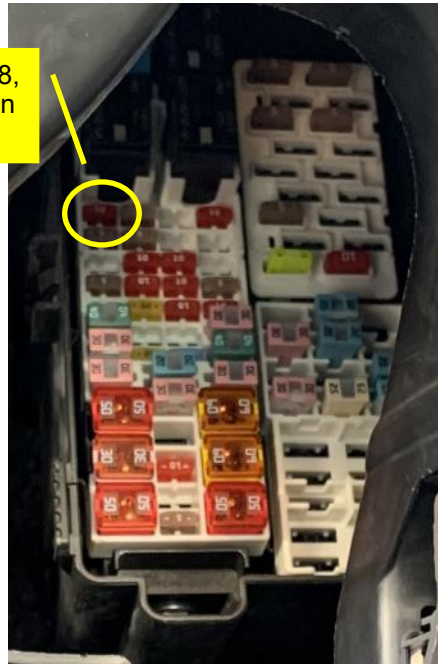
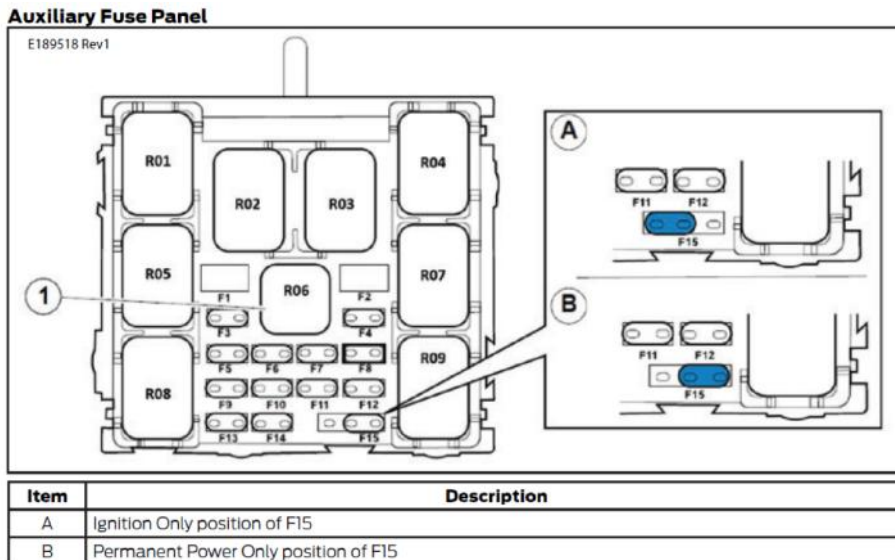
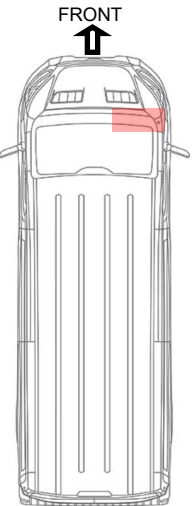

Figure 5-5: Diagram of Add-A-Fuse

- The Fuse Panel is located behind the knee bolster and can be accessed after bolster removal step.

Figure 5-3: Fuse Panel Diagram Figure 5-4: Fuse Panel Photo

Fuse Panel: 67C Option Switch power source location [KIT *62046]



- The Auxiliary Fuse Panel is located behind the glovebox and can be accessed after glove box removal step.
- Move fuse 15 to position labeled "B" to the blue Permanent power only position in Figure 5-5 to the left.

Figure 5-5: Option 67C Auxiliary Fuse Panel

Model Year 2026+ Fuse Panel Add-a-Fuse Location

Note: New Fuse Box shape for 2026 and beyond. Same fuse locations with or without 67C.

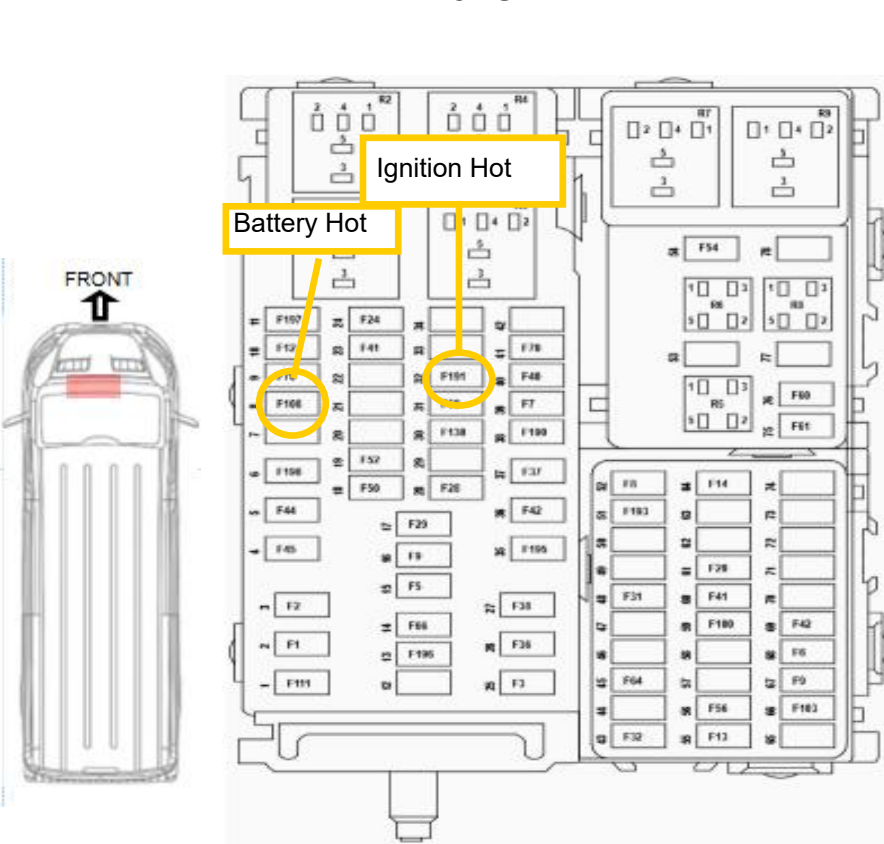

Without 67C

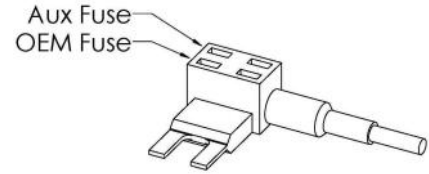

- The Fuse Panel is located behind the knee bolster and can be accessed after bolster removal step.
- Position 32 F191 is 10A Ignition hot.
- Position 8 F108 is Battery hot.

With 67C

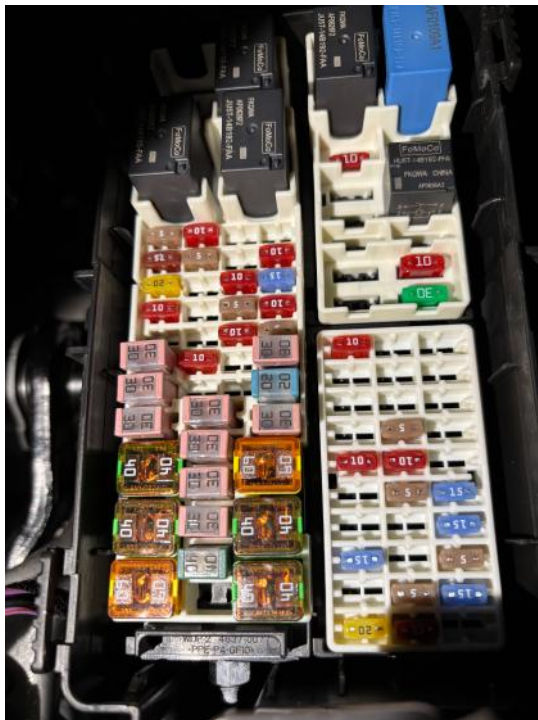

Section 6: Chassis Battery (CB) Access:

Step 6-1. Remove Carpet Strip Behind Drivers Seat

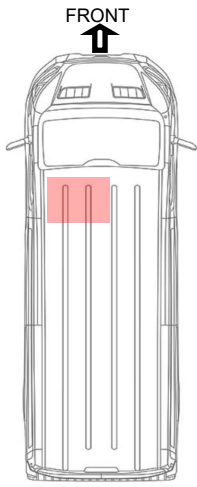

- Move the driver's seat fully forward and adjust to highest height if possible.
- Remove carpet strip if present [Yellow Arrow].
- It mounts with plastic fasteners in holes. A plastic trim tool may help to pry out the fasteners that hold down the carpet strip.

Step 6-2. Remove Loom Clipped to T-Bracket



- Remove clip holding a wire loom leaving the battery box.
- The same loom's grommet will be able to slide out as the bracket is being removed.

Step 6-3. Remove Rear T-Bracket Fasteners

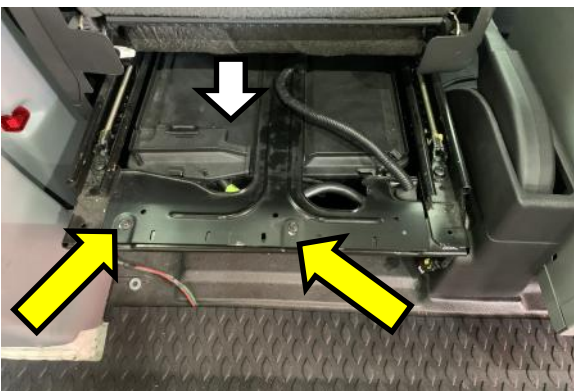

- Remove both T-bracket fasteners as shown (Yellow Arrows) at the rear of the seat [8mm or 10mm socket].
- Remove the steel T-bracket by pulling rearward.
- Remove the battery compartment (White Arrow) cover. Remove side clips retaining the plastic cover and remove to gain access to the battery terminals.

Section 6A: Single Chassis Battery (1CB) CABLE Routing [KITS 66007 and ±66221]

Step 6A-1. Identify Correct Lug Hole Diameters

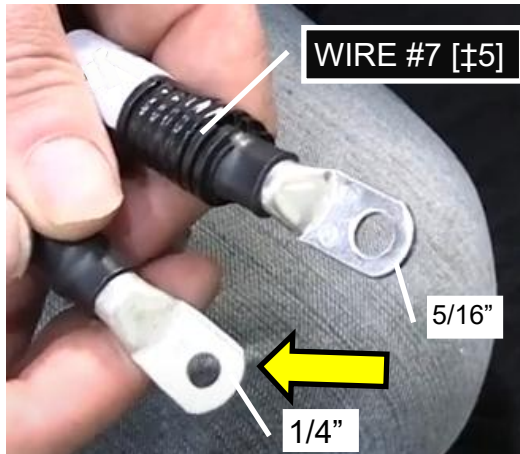
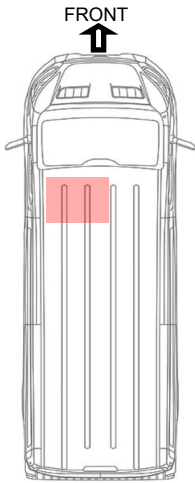

- Observe both ends of **WIRE #7 [±5]**.
- One end has a 1/4" hole in the terminal, the other end has a 5/16" hole in the terminal.
- The 1/4" hole lug [Yellow Arrow] will be installed onto the terminal on the CB negative battery clamp.

Key: If two "WIRE" numbers: Use WIRE #x for KIT 66007 and [±y] for KIT 66221

Step 6A-2. Wire #5 to Negative Battery Post



Caution: Control this negative cable, place the free end away from the battery. Tape off free end if possible.

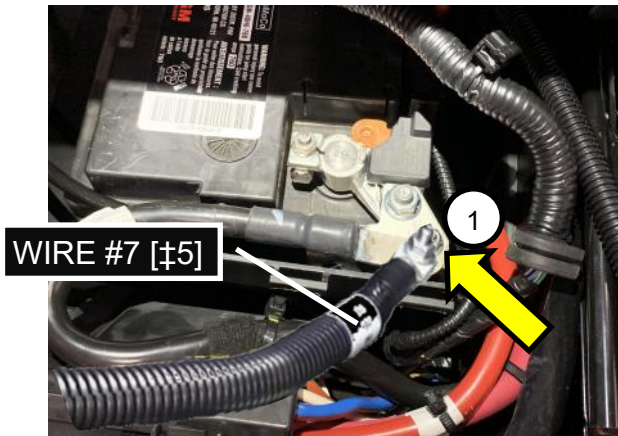

- Remove the nut on the battery ground [See Yellow Arrow] and install **WIRE #7 [±5]** [1/4" lug terminal] onto this smaller terminal.

- 1 Torque the **WIRE #7 [±5]** to 8Nm [+/- 1.2Nm] (71lb.in) with 10mm socket

Step 6A-3. Mount the MEGA Fuse Holder to Plate



Do not torque down the KEPS nuts. It may split the plastic. Hand tighten firm (~4Nm /36in lb.).

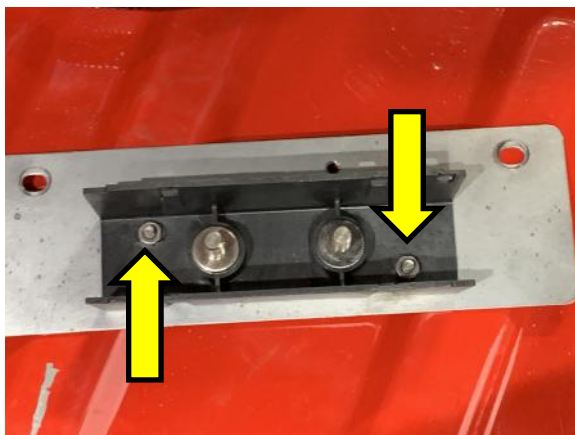

- Remove the cover and parts from the Vanner MEGA fuse holder.
- Assemble the flat washer, split washer, and then nuts on the terminals for safe keeping (or set aside).
- Place the bottom portion on the metal plate bracket included in the kit.
- Fasten down [KEPS nuts (Ref. NO.:19)] with nut with serrated washers. Use 3/8" nut driver and ensure they are snug.

Section 6A: Single Chassis Battery (1CB) CABLE Routing [KITS 66007 and ±66221]

Step 6A-4. Connect WIRE #1 to Fuse Holder

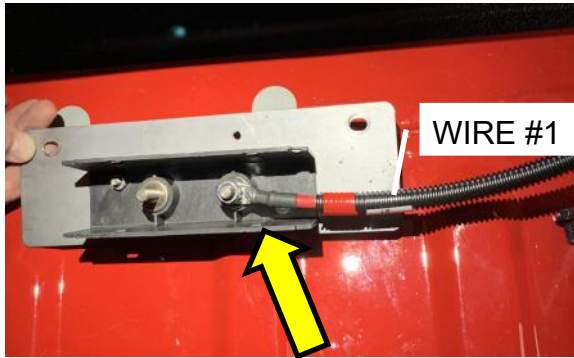
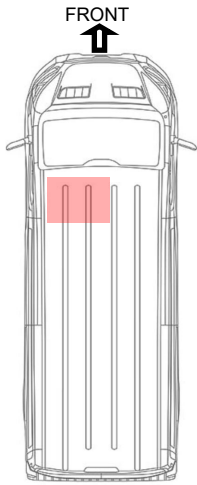

Caution: The fuse holder protects the end of the WIRE #1 from grounding

- **NOTE - WIRE #1** has 1/4" and 5/16" lug similar to **WIRE #7 [±5]** .
- Connect the end of **WIRE #1** with the 5/16 hole to the empty fuse lug as shown (Terminal to the right).
- Gently tighten fuse nut (Ref. NO.:18) to hold cable onto stud. (Use 1/2" Nut driver)
- This wire is secured against grounding.

Key: If two "WIRE" numbers: Use WIRE #x for KIT 66007 and [±y] for KIT 66221

Step 6A-5. Prepare Positive Battery Terminal

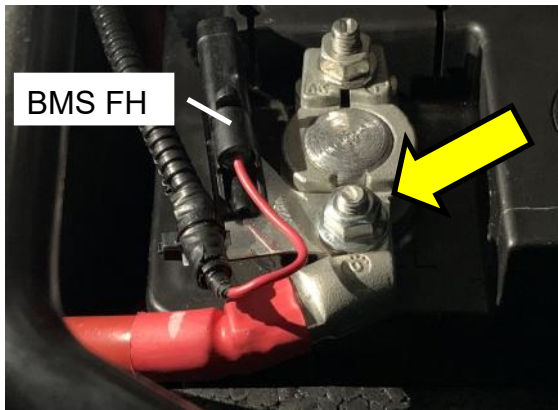
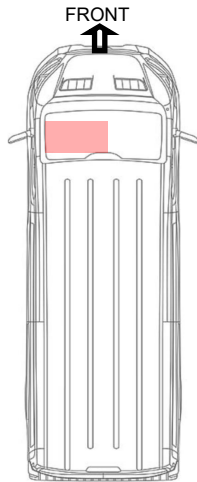

- Move the seat carefully rear-ward so that positive (+) battery terminal can be accessed.
- Loosen nut [see Yellow Arrow] and remove BMS Fuse Holder (FH) fastener (Ref. NO.:16)
- From the back of the seat, pull the 1/4" lug of **WIRE #1** near the positive post.

Step 6A-6. Prepare Busbar



- The 1/4" hole end of **WIRE #1** and the BMS fuse holder will attach to this busbar (Ref. NO.:17) terminal [at Yellow Arrow] (using FAS0159 (Ref. NO.: 7)).
- The busbar will be connected to the terminal on the positive battery clamp (See Blue Arrow).

Section 6A: Single Chassis Battery (1CB) CABLE Routing [KITS 66007 and ±66221]

Step 6A-7. Connection to Busbar

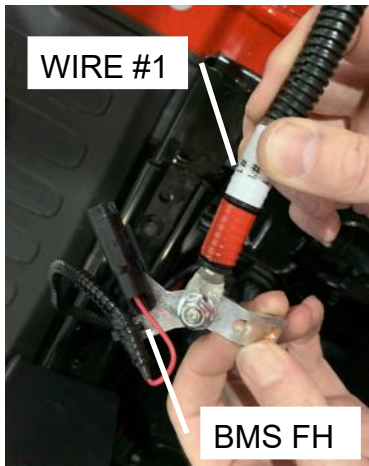
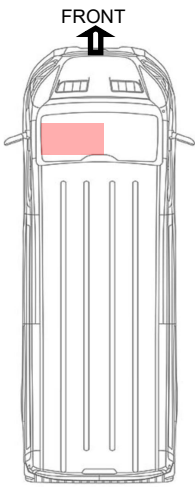

- Use the supplied FAS0159 nut, connect **WIRE#1** and the BMS fuse holder to the busbar terminal.
- The busbar is prepared to be assembled onto the battery clamp terminal.
- Leave the fasteners finger tight for adjustment and tightening in next step.

Step 6A-8. Attach the Busbar



Caution: Use high caution or insulated wrenches when tightening on battery post!



- The busbar assembled with the wires is placed onto the terminal on the battery clamp.
- 1 Torque the busbar to battery clamp to 8Nm [+/- 1.2Nm] (71lb.in) with 10mm Socket.
 - 2 Torque the **WIRE #1** and BMS fuse holder on the busbar to 8Nm [+/- 1.2Nm] (71lb.in) with 10mm Socket.

Step 6A-9. Neatly Route WIRE #1

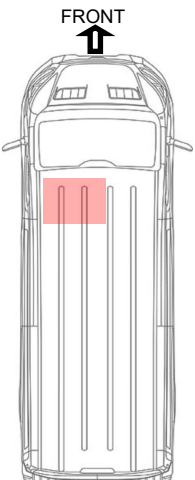

- Push the seat all the way forward and go to area behind the seat.
- The **WIRE #1** battery cable will be pushed, routed and tucked straight back into the space between the battery and the plastic battery bin.

Section 6A: Single Chassis Battery (1CB) CABLE Routing [KITS 66007 and ±66221]

Step 6A-10. Replace Plastic Battery Cover

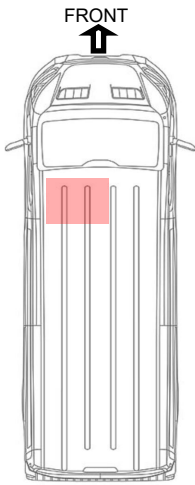

- The cover will slide in and snap onto the plastic battery box.
- The small plastic negative battery post cover is removed so that it may be notched.

Step 6A-11. Notch Battery Cover for Cables



- A pair of tin snips can be used to cut the notch in the cover so that the thick cable may exit the battery area when the covers are in place.

Step 6A-12. Steel T- Bracket Installation



Caution: The battery is secured by this bracket— ensure proper positioning.

- Replace the T-bracket
- Make sure the leading edge [Yellow Arrow] of bracket is secured in the correct location beneath the edge of the front of the seat base.

Section 6A: Single Chassis Battery (1CB) CABLE Routing [KITS 66007 and ±66221]

Step 6A-13. Steel T- Bracket Installation

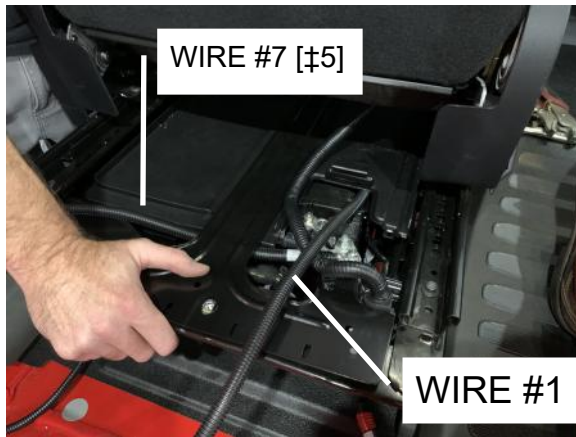
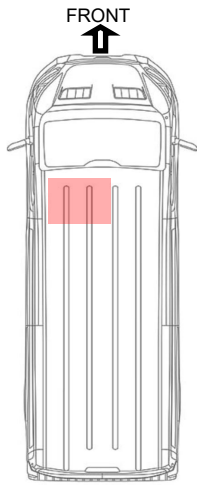

Caution: The battery is secured by this bracket— position properly.

- The T-bracket is pushed forward and the two wires [WIRE #1 & WIRE #7 [±5]] are brought / routed above the bracket.
- The other loom is then pushed back into the grommet slot on the T-bracket.

Key: If two “WIRE” numbers: Use WIRE #x for KIT 66007 and [±y] for KIT 66221

Step 6A-14. Neatly Route Cables

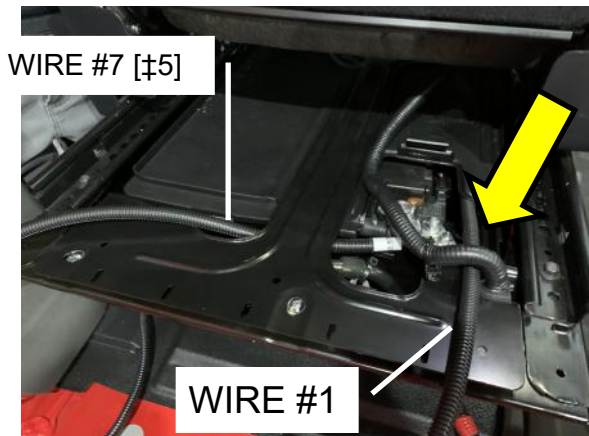

- The **WIRE #1** fits well under the corrugated harness (Yellow arrow pointing at loop). This harness is pushed into groove on steel bracket and clipped at the edge opposite the groove.
- Make sure **WIRE #7 [±5]** is routed out from under to above the bracket.

Step 6A-15. Re-install Negative Battery Post Cover



- Loosely reposition the plastic Negative Battery Post cover to locate where notch shall be for **WIRE #7 [±5]**.
- Cut or trim notch in plastic cover so that it can snap in with **WIRE #7 [±5]** present.

Section 6A: Single Chassis Battery (1CB) CABLE Routing [KITS 66007 and ±66221]

Step 6A-16. Fasten WIRE #2 to Fuse Holder

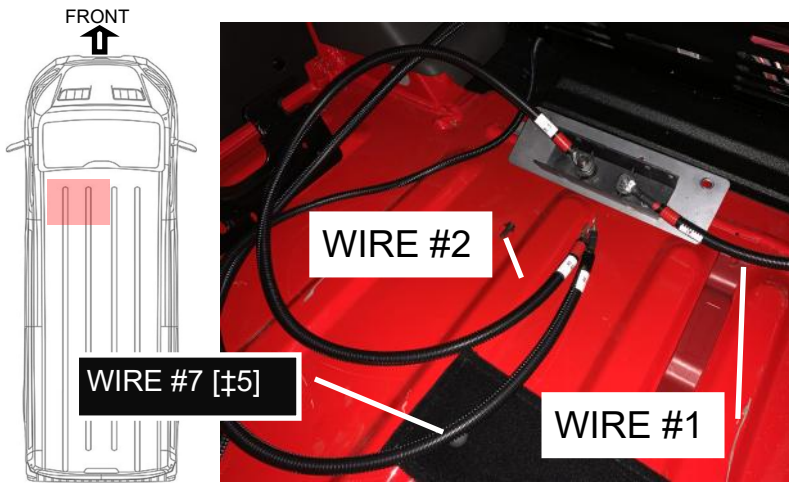

Caution: There will be no fuse installed at this point.

- On the fuse holder that is already attached to **WIRE #1**, attach **WIRE #2** to the other fuse holder post and lightly tighten the fastener (Ref. NO.:18).
- Notice **WIRE #7 [±5]** from the negative post is present in the photo.
- These two wires [**WIRE #2 & WIRE #7 [±5]**] will be connected to the AUX Battery setup.

Key: If two "WIRE" numbers: Use WIRE #x for KIT 66007 and [ty] for KIT 66221

Step 6A-17. Re-install Carpet Strip & Mount Fuse



- Replace the carpet strip into its position (Yellow Arrow).
- Flip it forward to expose holes for the steel battery hold down T-Bracket.
- Using the fasteners (Ref. NO.:26) that secure the T-Bracket over the battery, line up holes in fuse holder bracket with the T-Bracket and install the fuse holder on top of T-Bracket.
- The tightening torque for these 8mm/10mm fasteners is 10Nm [±1.5Nm] (89lb.in).
- Extra length of **WIRE#1** will push in beneath the battery cover and go into space beside battery as mentioned in Step **6A-9**.

Section 6B: Two Chassis Battery (2CB) CABLE Routing [KIT *62046 and 60331]

Step 6B-1. Observe Double Battery Orientation

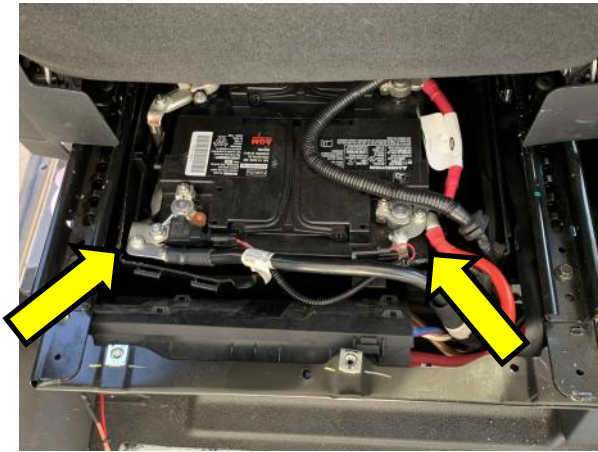
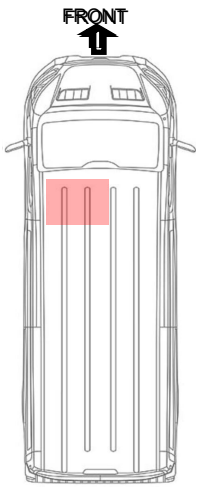

Section 6B Key: If two “WIRE” numbers: Use WIRE “#(y)” for KIT 62046 and “[y]” for KIT 60331. If one “WIRE” number, both use same wire number.

- In this configuration, the batteries are arranged so that both of the terminal on the battery Positive (+) and Negative (-) clamps are accessible from only behind the seat.
- Push seat fully forward and lift to highest position if possible.

Step 6B-2. Identify Correct Lug Hole Diameters

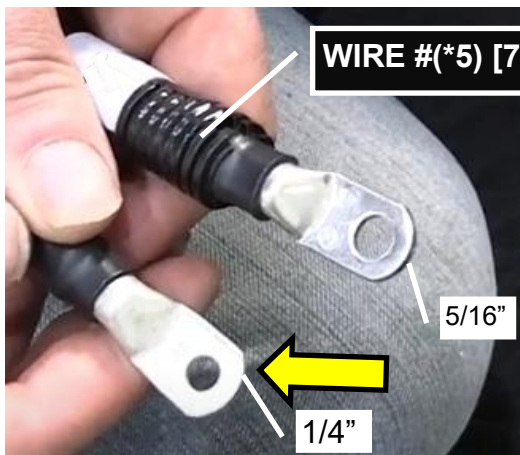

- Observe both lug ends of **WIRE #(5) [7]**.
- One end has a 1/4” hole in the terminal, the other end has a 5/16” hole in the terminal.
- The 1/4” hole lug will be installed onto the terminal on the CB negative battery clamp.

Step 6B-3. Install Wire # to Negative Battery Post

60331

62046

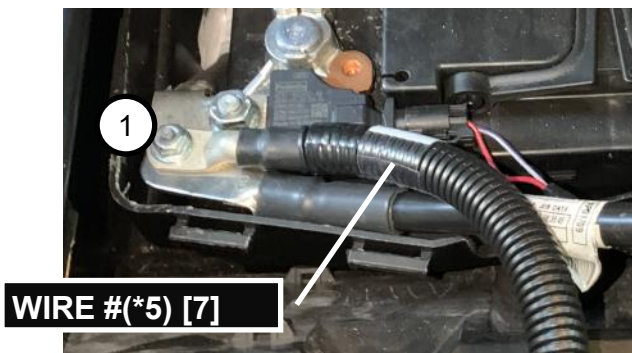

- With the supplied (FAS0159 (Ref. NO.:7)) nut install **WIRE #(*5) [7]**, [1/4” terminal] onto this smaller terminal.
- ① Torque the wire to 8Nm [+/- 1.2Nm] (71lb.in) with 10mm socket.
- Tuck the other end of the **WIRE #(*5) [7]** out of the way. For safety it may be taped with electrical tape.

Section 6B: Two Chassis Battery (2CB) CABLE Routing [KIT *62046 and 60331]

Step 6B-4. Identify Correct Lug Hole Diameters

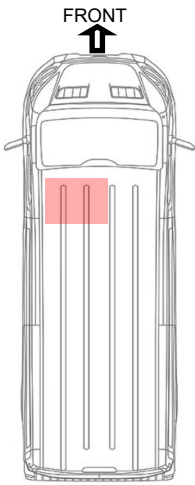

- The cabling kit that is used may have a shorter **WIRE #1**. This is because the positive battery post is closer to the MEGA Fuse mounting location.
- Observe the different sized holes.

WIRE #1 has 1/4" and 5/16" lug (similar to **WIRE #(5) [7]**).

Step 6B-5. Connect WIRE #1 to CB Fuse Holder



Caution: The fuse holder protects the end of the WIRE #1 from grounding



- Fasten down the fuse holder to the mounting plate [KEPS nuts (Ref. NO.:19) with nut with serrated washers. Use 3/8" nut driver and ensure they are snug.
- Connect the end of **WIRE #1** with the 5/16 hole to the empty fuse lug as shown (Terminal to the right).
- Temporarily, gently tighten fuse nut (Ref. NO.: 18) to hold cable onto stud. (Use 1/2" Nut driver).

Step 6B-6. Locate and Loosen *BMS* Fuse Holder Fastener

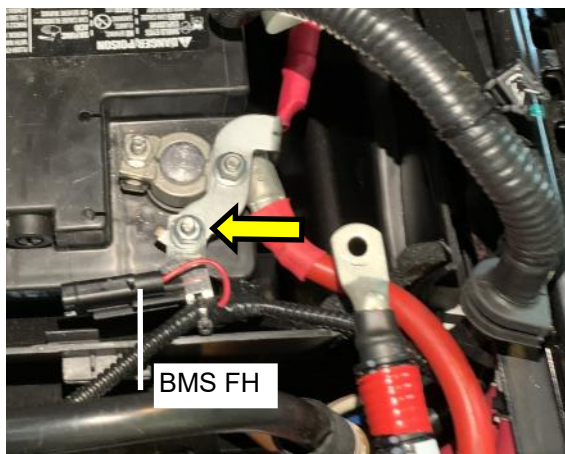

- Loosen nut [see Yellow Arrow] and remove *BMS* fuse holder (FH) fastener.

60331

62046

Section 6B: Two Chassis Battery (2CB) CABLE Routing [KIT *62046 and 60331]

Step 6B-7. Connection to Positive Terminal

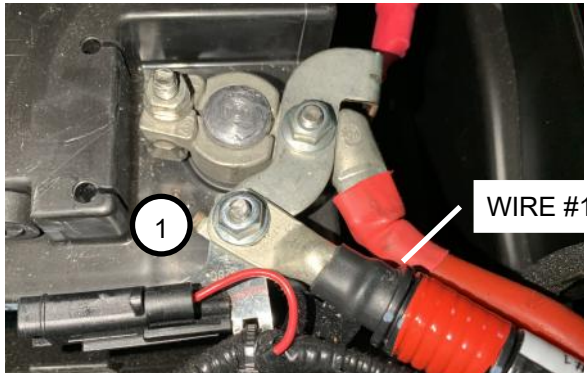
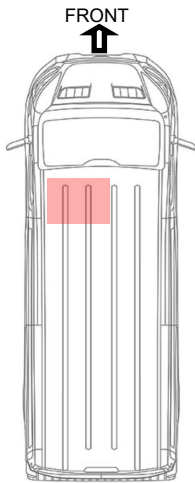

Caution: Use high caution or insulated wrenches when tightening on battery post!

- Use the supplied FAS0159 (Ref. NO.: 7) nut, connect **WIRE #1** and the *BMS* fuse holder to the terminal.
- ① Torque the **WIRE #1** and *BMS* fuse holder on the busbar to 8Nm [\pm 1.2Nm] (71lb.in) with 10mm Socket.

Step 6B-8. Cable Routing

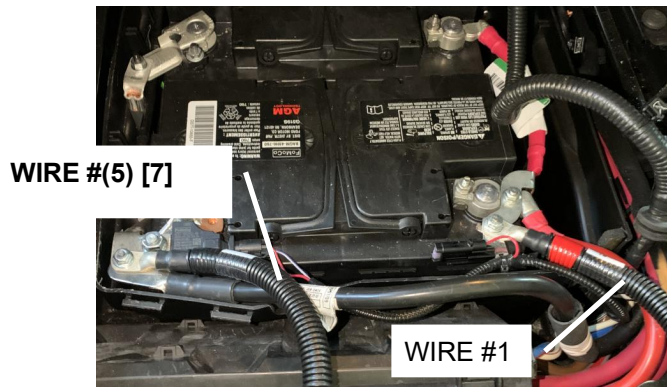

- Observe cable routing to prepare for notches to cut into battery cover.

Step 6B-9. Neatly Route WIRE #1

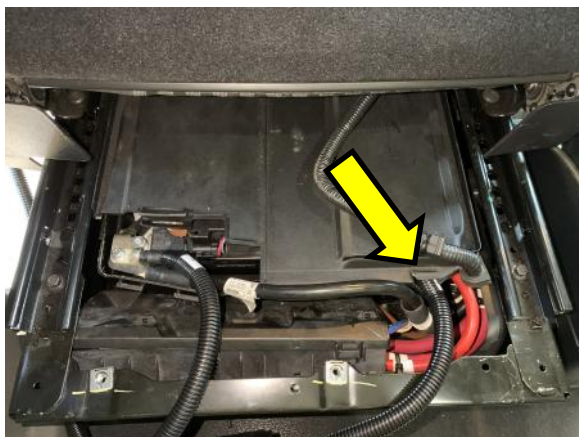

- Return the battery cover back over the batteries.
- Observe the notch cut for **WIRE #1** (Yellow Arrow).

60331

62046

Section 6B: Two Chassis Battery (2CB) CABLE Routing [KIT *62046 and 60331]

Step 6B-10. Connection to Positive Terminal

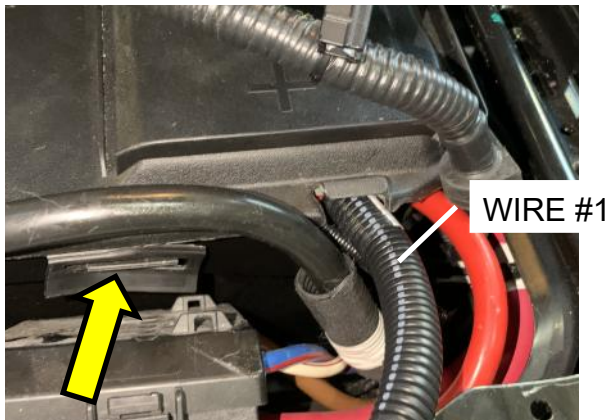
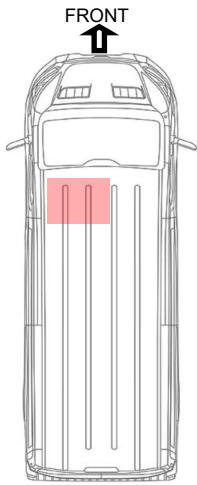

- Be sure battery cover can snap down over **WIRE #1** (At Yellow Arrow).

Step 6B-11. Cable Routing for WIRE #(*5)



- Observe **WIRE #(5) [7]** cable routing to prepare for notches to cut into small battery cover.

Step 6B-12. Adjust Small Negative Battery Terminal Cover

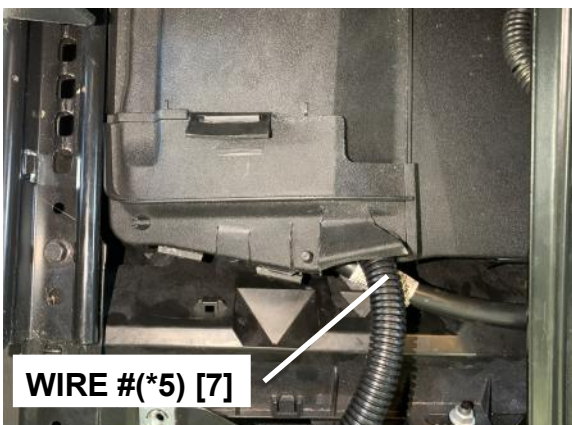

- In order to have the cover fasten back to larger battery cover, making a notch is necessary.
- The notch is cut using tin snips.
- The cover should be able to utilize existing snap on points to the larger cover.

60331

62046

Section 6B: Two Chassis Battery (2CB) CABLE Routing [KIT *62046 and 60331]

Step 6B-13. Re-installing the T-Bracket

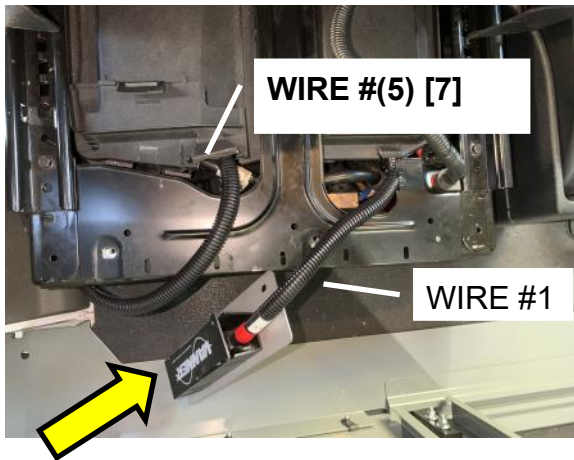
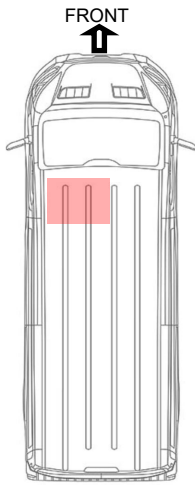

- Return the T-Bracket over the batteries and under **WIRE #1 & WIRE #(5) [7]**
- The MEGA fuse holder base plate (Yellow Arrow) will match with the two fastener holes for the T-Bracket.

Step 6B-14. Re-installing MEGA Fuse Holder



Caution: There shall be no fuse installed at this point.

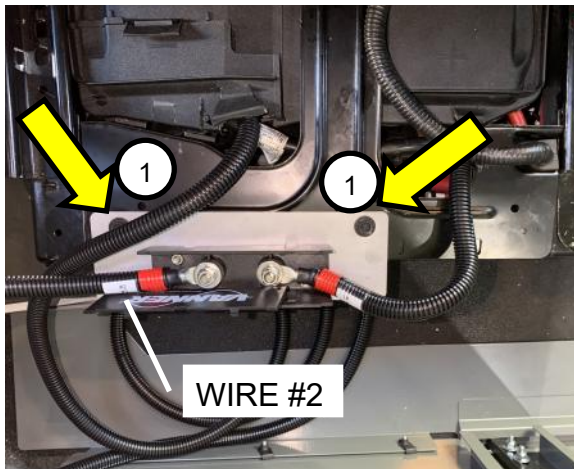

- Line up holes in fuse holder bracket with the T-Bracket and install the fuse holder on top of T-Bracket.
- ① The tightening torque for these 8mm fasteners (Ref. NO.:26) is 10Nm [+/- 1.5Nm] (89lb.in).
- Attach **WIRE #2** to the open post on the MEGA fuse holder. Hand tighten its 1/2" nut (Ref. NO.:18).

Step 6B-15. Re-installing Carpet Strip

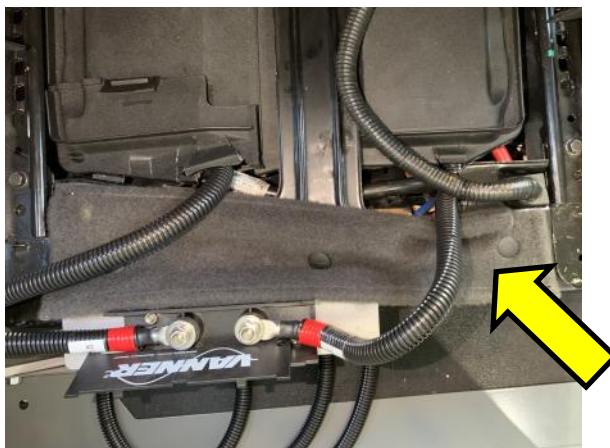

- Replace carpet strip if present [Yellow Arrow].

60331
62046

Section 7A: Vehicle Interface For Non-67C Application [KITS 66007 and ±66221]

Step 7A-1. Locating the Remote Switch

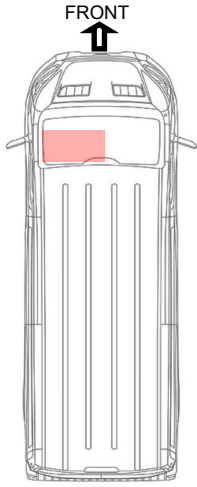

- Slide seat *back* to access the area beneath the steering wheel.
- The recommended location of the Inverter remote switch is shown with a red dot on the knee bolster.
- Measurements shown in Step 7A-3 below.

Step 7A-2. Locating the Remote Switch



- Remove knee bolster beneath the steering wheel. It can be removed by pulling straight towards the driver seat. A plastic trim tool may aid in removal.
- Red dot is approximate placement of switch. A hole will be placed in this position.

Step 7A-3. Measuring and Making Switch Hole



Be aware that there are supports and circuitry behind the panel— this hole and switch needs to be located as to not interfere.

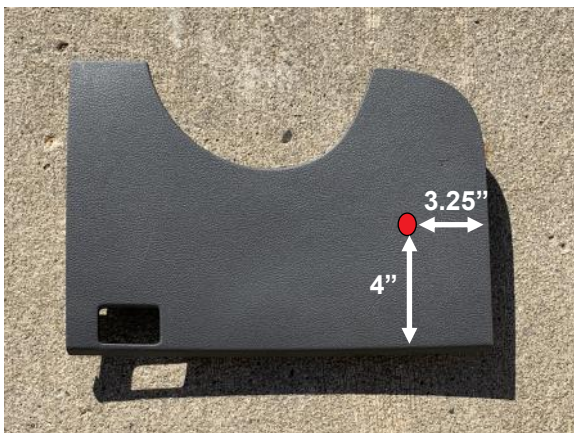

- The button location is 3.25" from the right side edge and 4" above the bottom edge of the knee bolster panel.
- A hole diameter of 3/4" [19mm] is necessary to install the snap in switch [do not insert switch yet].

Section 7A: Vehicle Interface For Non-67C Application [KIT 66007 ONLY]

Step 7A-5. 66007 Remote Switch Harness Layout



Diagram 7A-1: Remote Switch Harness Kit



Be aware that the switch will not be connected until after the harness is installed and the knee panel is being installed.

- ①① ADD-A-FUSE WIRE to SWITCH, “**WIRE #11**”- RED wire, Black Corrugate, HAAT
- ①② GROUND WIRE to SWITCH, “**WIRE #12**” - BLACK wire, Ground
- ①③ TIMER to INVERTER “**WIRE #13**” - ORANGE wire, Black Corrugate, Remote Signal

DIAGRAM 7A-5: The 66007 Remote Switch Harness Diagram.

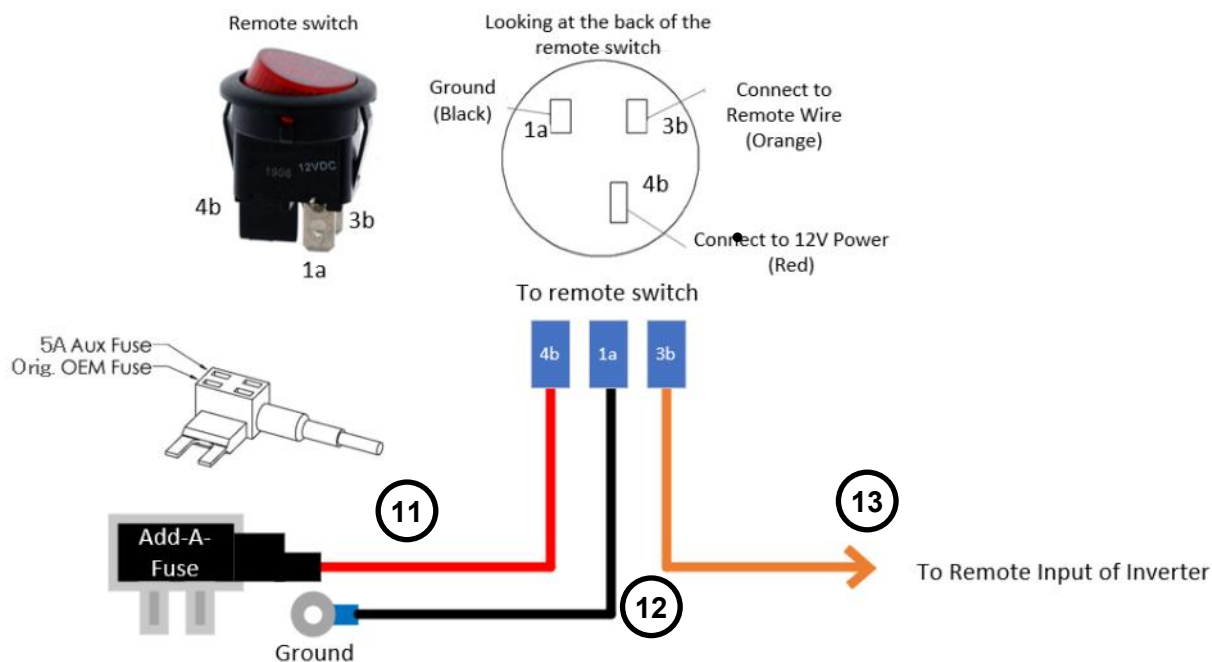
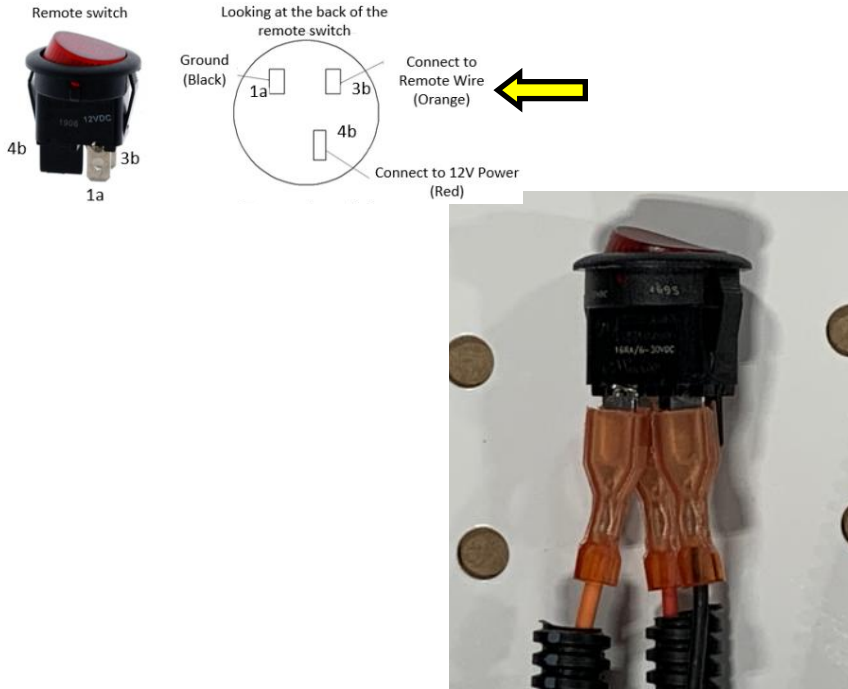

Diagram 7A-2: Remote Switch Harness Kit Schematic

- A diagram of the remote switch harness assembly is shown in image above.
- It is pre-assembled excluding the switch, which is separate.
- The remote switch will be installed in the panel under the steering wheel as shown in Step **7A-2**.
- The three spade connectors attached to color coded wire will be attached to the terminals of the switch after pulling them through the hole made in the knee bolster as shown above.

Section 7A: Vehicle Interface For Non-67C Application [KIT 66007 ONLY]

Step 7A-6. Preparation to Connect 66007 Remote Switch



- The crimped on spade terminals of **WIRES #11, #12, and #13** will be pushed firmly onto the stakes of the provided switch (according to Diagram 7A-2) ***after*** being pulled through the switch hole drilled earlier in the knee bolster.

Diagram 7A-3: KIT 66007 Remote Switch Connections

Section 7A: Vehicle Interface For Non-67C Application [KIT #66221 ONLY]

Step 7A-7. PRE-ASSEMBLED 66221 Timer Harness Layout

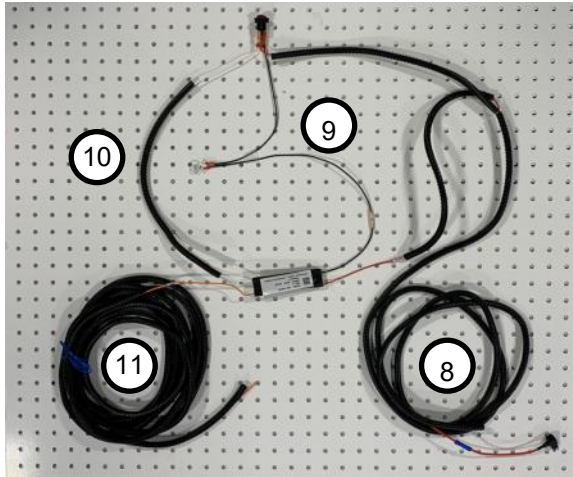

Diagram 7A-4: Remote Harness Layout



Be aware that the switch will not be connected until after the harness is installed and the knee panel is being installed.

- 8 ADD-A-FUSE WIRE to SWITCH and TIMER, “WIRE # 8”- RED wire, Black Corrugate, HAAT
- 9 GROUND WIRE to SWITCH and TIMER, “WIRE # 9” - BLACK wire, Ground
- 10 REMOTE SWITCH to TIMER “WIRE # 10” - WHITE wire, Black Corrugate, Switch Signal
- 11 TIMER to INVERTER “WIRE # 11” - ORANGE wire, Black Corrugate, Remote Signal

DIAGRAM 7A-8: The 66221 Remote Switch Harness Diagram.

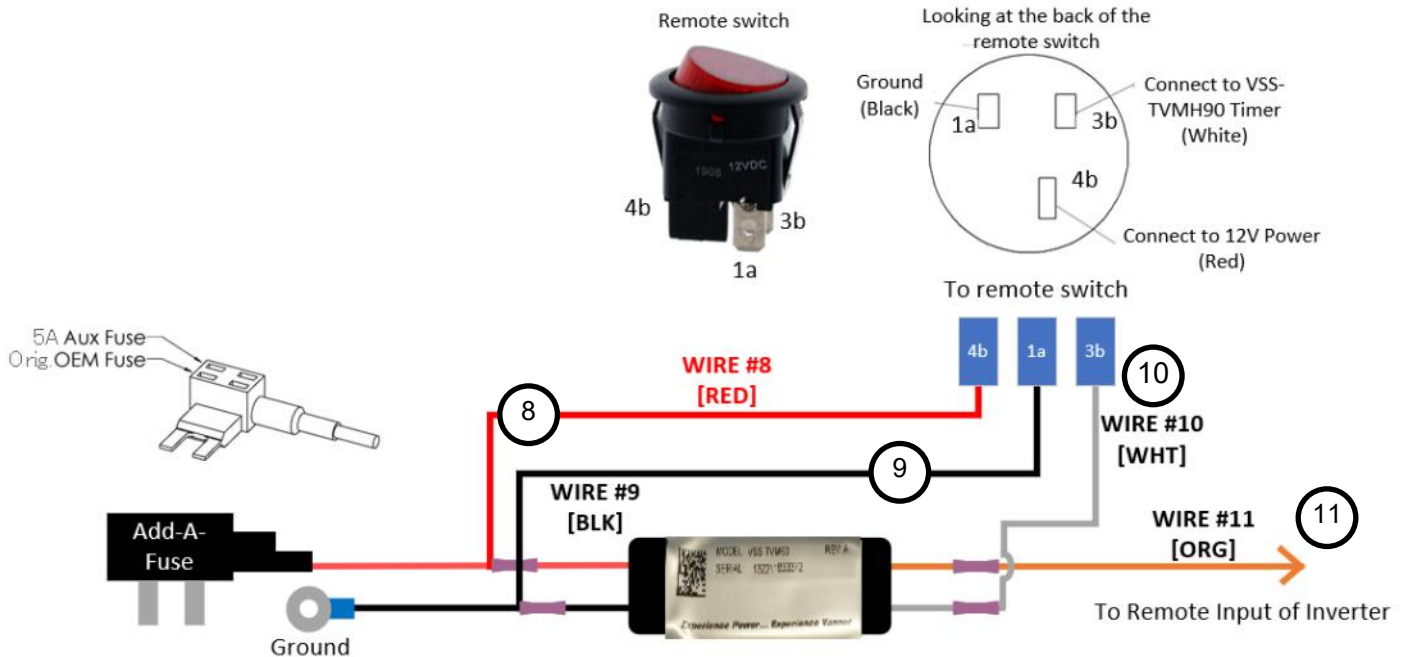
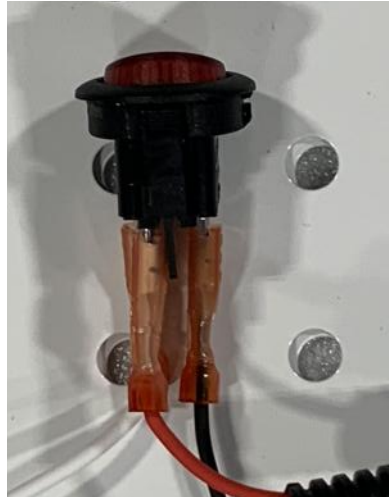
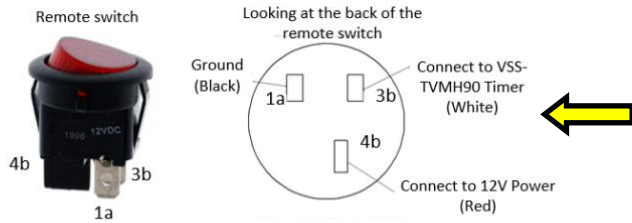

Diagram 7A-5: Remote Switch & Timer Harness Kit

- A diagram of the remote switch and timer harness assembly is shown in image above.
- It is pre-assembled excluding the switch, which is separate.
- The remote switch will be installed in the panel under the steering wheel as shown in Step 7A-2.
- The three spade connectors attached to color coded wire will be attached to the terminals of the switch after pulling them through the hole made in the knee bolster as shown above.

Section 7A: Vehicle Interface For Non-67C Application [KIT #66221 ONLY]

Step 7A-9. Preparation to Connect 66221 Remote Switch



- The crimped on spade terminals of **WIRES #8, #9, and #10** will be pushed firmly onto the stakes of the provided switch (according to Diagram 7A-5) **af-ter** being pulled through the switch hole drilled earlier in the knee bolster.

Diagram 7A-6: KIT 66221 Remote Switch Connections

Section 7A: Vehicle Interface For Non-67C Application [KITS 66007 and ±66221]

Step 7A-9. Switch Installation

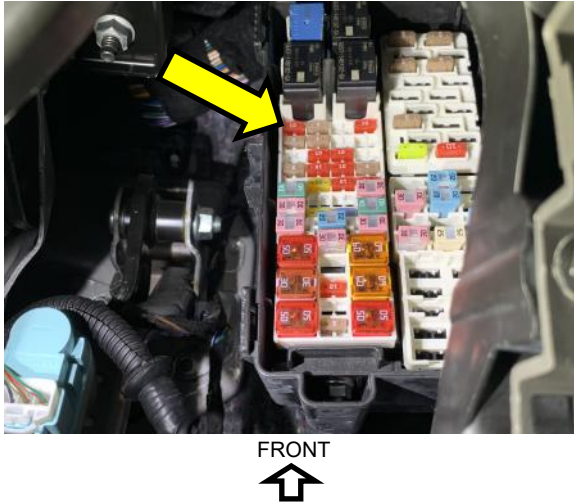
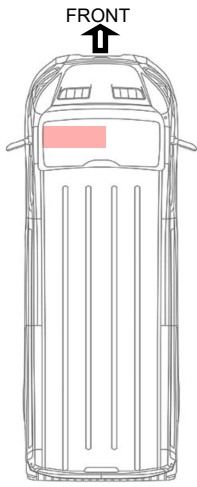

For Model Year 2026+ Fuse Panel Add-a-Fuse Location, see next page

- Find F-76 according to the fuse block diagram in Section 5, **Figures 5-3/5-4**.
- Remove Fuse (F-76: 10A [Red])

Step 7A-10. Insert Fuses into Add-A-Fuse

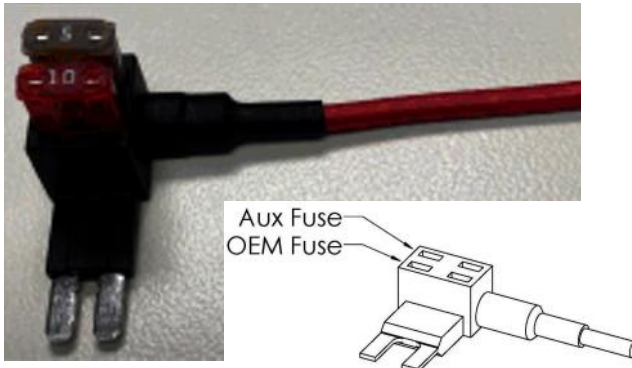

- Remove Fuse #76's Fuse and put it into the Add-A-Fuse holder as shown [10A Red].
- The 5A AUX Fuse piggyback fuse is for the inverter's remote switch.

Step 7A-11. Insert the Add-A-Fuse into Panel



- The Add-A-Fuse will be pushed into the space of Fuse #76.
- The other side of the wire is a covered terminal for prevention of shorting to ground.
- That terminal will be connected to the timer/switch or switch depending on KIT.

Model Year 2026+ Fuse Panel Add-a-Fuse Location

Note: New Fuse Box shape for 2026 and beyond. Same fuse locations with or without 67C.

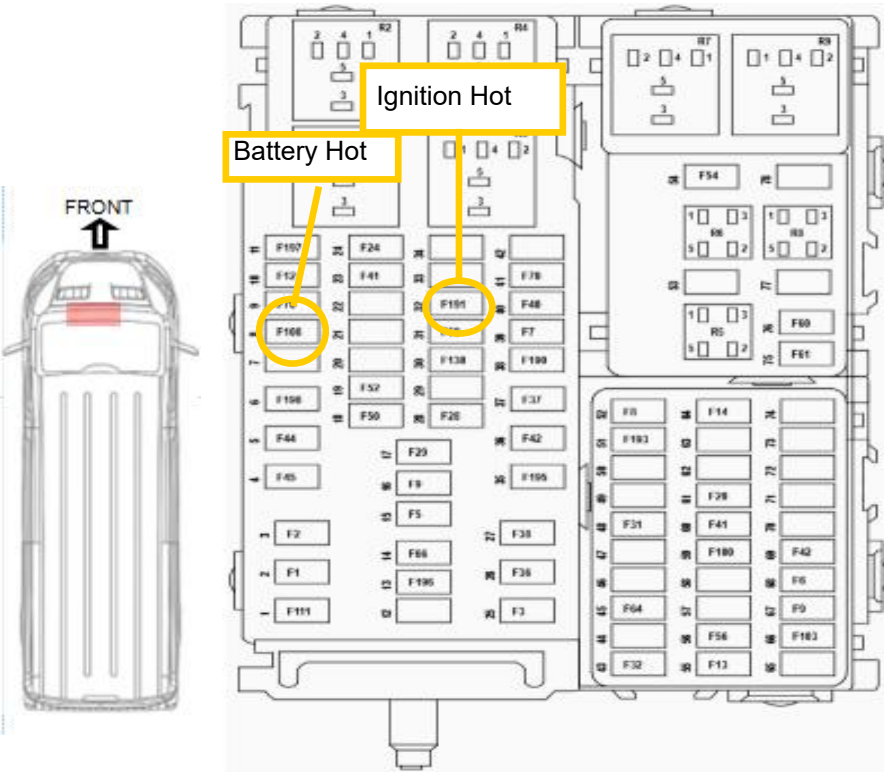

Without 67C

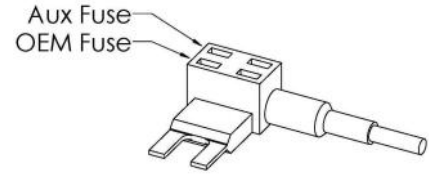

- The Fuse Panel is located behind the knee bolster and can be accessed after bolster removal step.
- Position 32 F191 is 10A Ignition hot.
- Position 8 F108 is Battery hot.

With 67C

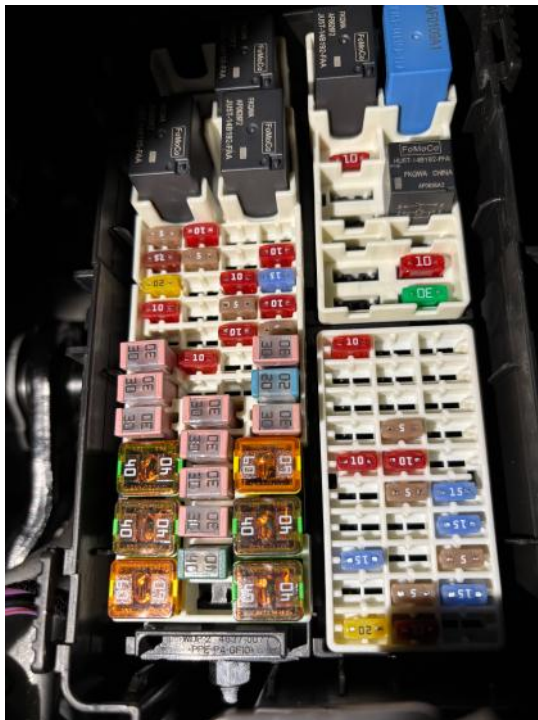

Section 7A: Vehicle Interface For Non-67C Application [KITS 66007 and ±66221]

Step 7A-12. Switch or Switch/Timer Fitment in Dash Cavity

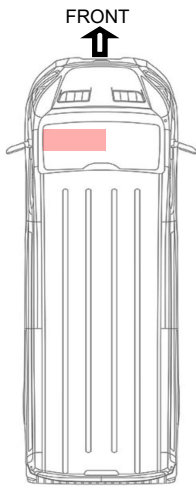

- With the Add-A-Fuse installed, the switch/timer (KIT 66221) or just switch (KIT 66007) harnessing may be brought into the area where the knee bolster would be installed for fitment.
- The harnessing should be tucked into the cavity out of the way of any moving parts and near a surface that it can be wire-tied appropriately.

Step 7A-13. Ground Ring Terminal with Self-tapping Screw

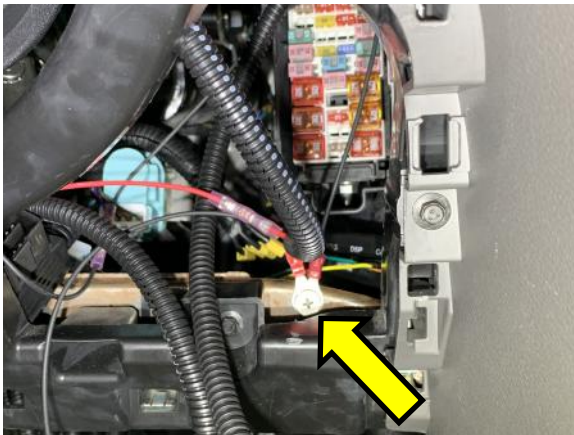

- The ground ring terminal on ground **WIRE #12 [±9]** is fastened to the steel sub-structure using a self-tapping screw (Tek screw Ref. NO.:11).
- Location chosen here (Yellow Arrow) allows easy fastening.

Key: Use **WIRE #x** for KIT 66007 and **[±y]** for KIT 66221

Step 7A-14. Remote Wire Routing

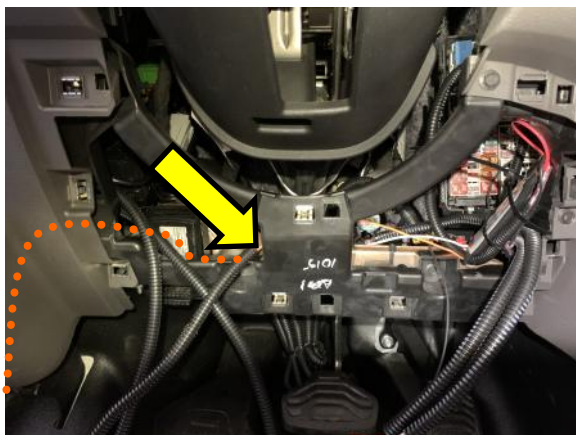

- The long Orange **WIRE #13 [±11]** remote wire will be fed behind and across the area under the steering wheel— behind the knee bolster support structure.
- This wire loom is routed to the street side and brought down through the inside door trim where it can be pulled through. Following path of orange dotted line.
- Avoid any steering linkage area.

Section 7A: Vehicle Interface For Non-67C Application [KITS 66007 and ‡66221]

Step 7A-15. Anchoring the Timer and Harness



Be aware that here are supports and circuitry behind the panel.



- Use nearby holes to wire tie fasten the excess wires to the inside of the dash where it will not interfere with the reinstallation of the knee bolster panel.
- Note the three switch spade terminal wires [Yellow Arrow] may need to be adjusted after they are pulled through the 3/4" hole just before panel is reinstalled [see below].
 - **For KIT 66007:** This three wire bundle will contain Red, BLK, & the separate Orange remote wire
 - **For KIT 66221:** this three wire bundle will contain Red, Black, & White wires from the timer harness.

Step 7A-16. Connect the Remote Switch

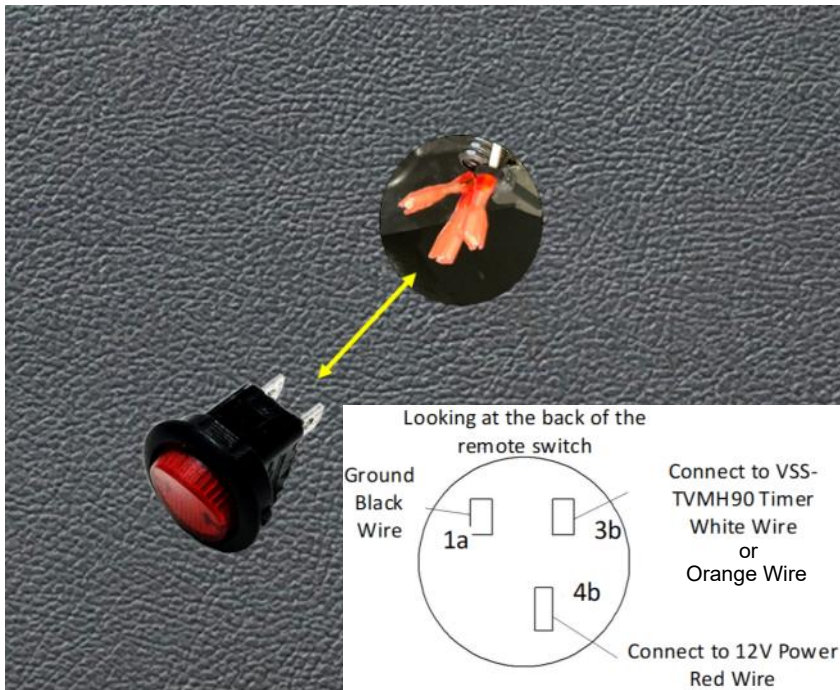

- Pull the three switch spade terminal wires through the knee bolster hole and connect according to wire color and stake diagram:
 - **For KIT 66007:** [1a (Black), 3b (White), 4b (Red)].
 - **For KIT 66221:** [1a (Black), 3b (Orange), 4b (Red)].
- Install the knee bolster after Orange WIRE #13 [‡11] is routed.

Key: Use WIRE #x for KIT 66007 and [‡y] for KIT 66221

Section 7A: Vehicle Interface For Non-67C Application [KITS 66007 and ±66221]

Step 7A-17. Remote Wire Routing

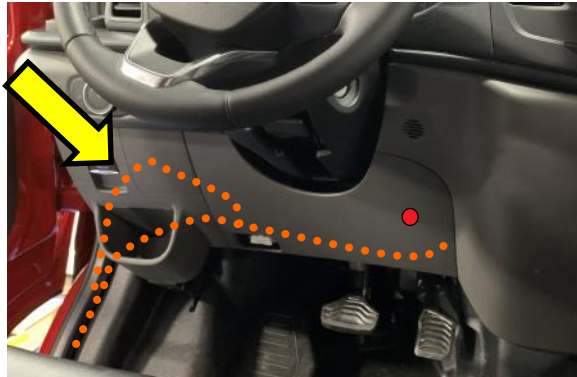
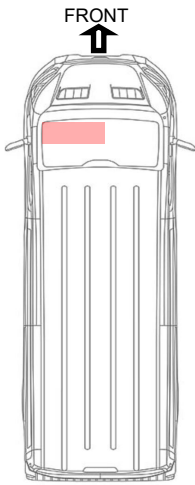

- When finished, the Orange **WIRE #13 [±11]** will follow a path similar to either of the orange dotted lines shown here.

Step 7A-18. Planning Routing for Orange



Caution: Be aware of steering shaft and any other mechanism-follow other wire routing.

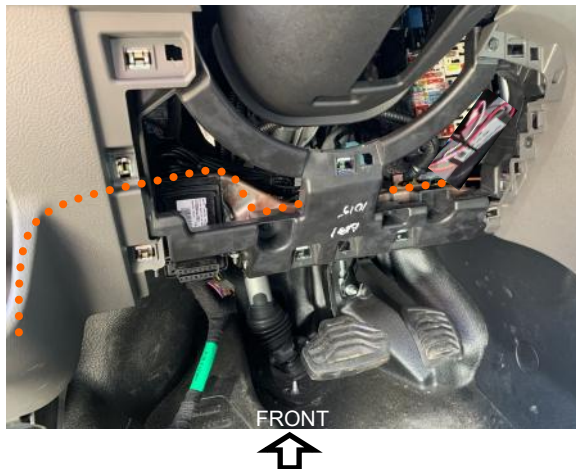

- The Orange **WIRE #13 [±11]** will route beneath the steering wheel inside the area behind the knee bolster. Be sure it lay flattened and cannot be caught up in the steering linkage. Use wire ties to anchor it down.
 - It may be routed behind the dash down through the driver's door frame trim.
- Key: Use WIRE #x for KIT 66007 and [±y] for KIT 66221**

Step 7A-19. Route Planning for Orange Remote Wire



- When reaching the end of the dash panel, the loom may be routed down through a channel to the door trim.

OR

- Routed down near the cup holder and then tucked up and to the side under the edge of the dash panel nearest to the door.

Section 7A: Vehicle Interface For Non-67C Application [KITS 66007 and 66221]

Step 7A-20. Routing of Remote Wire

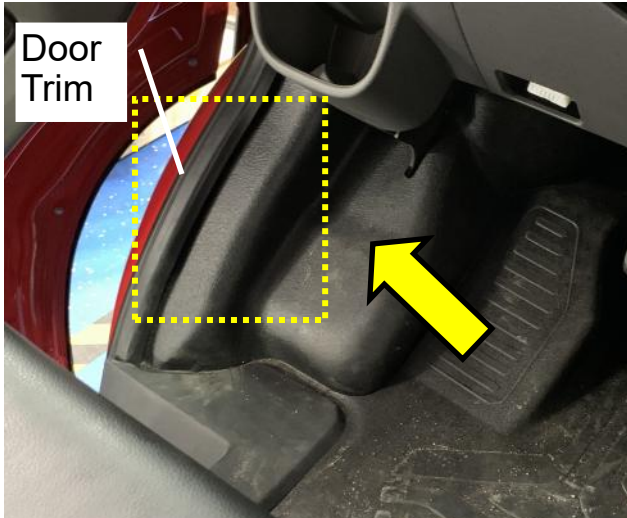
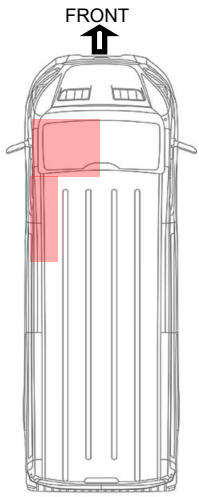

- As shown in Step 7A-19, the Orange **WIRE #13 (11)** loom will be hidden under this doorway trim.



Key: Use **WIRE #x** for KIT 66007 and **[y]** for KIT 66221

Step 7A-21. Moving Trim to Fit Wire Loom

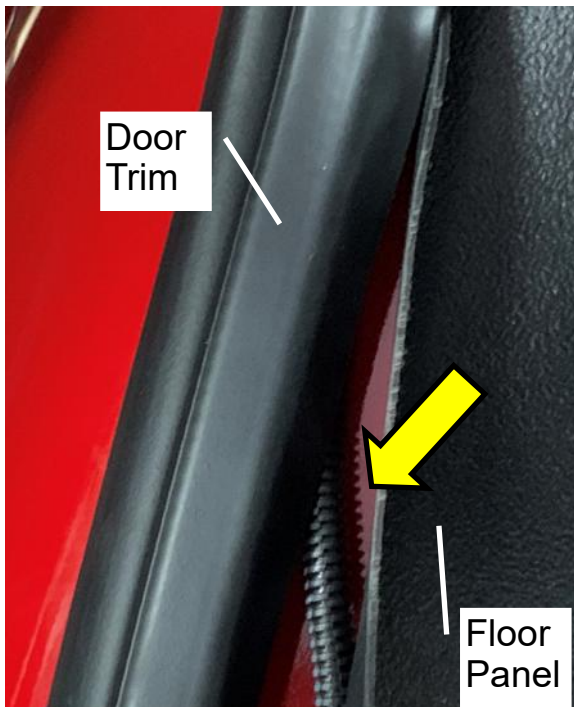

- After it has been pulled through from behind the dash board after the installation of the timer, the remote wire loom [corrugate shield] will compress and be hidden under the door trim.
- The floor panel should be returned in its position under the edge of the trim after loom is pressed beneath door trim.

Section 7A: Vehicle Interface For Non-67C Application [KITS 66007 and ±66221]

Step 7A-22. Routing of Remote Wire beneath Door Threshold

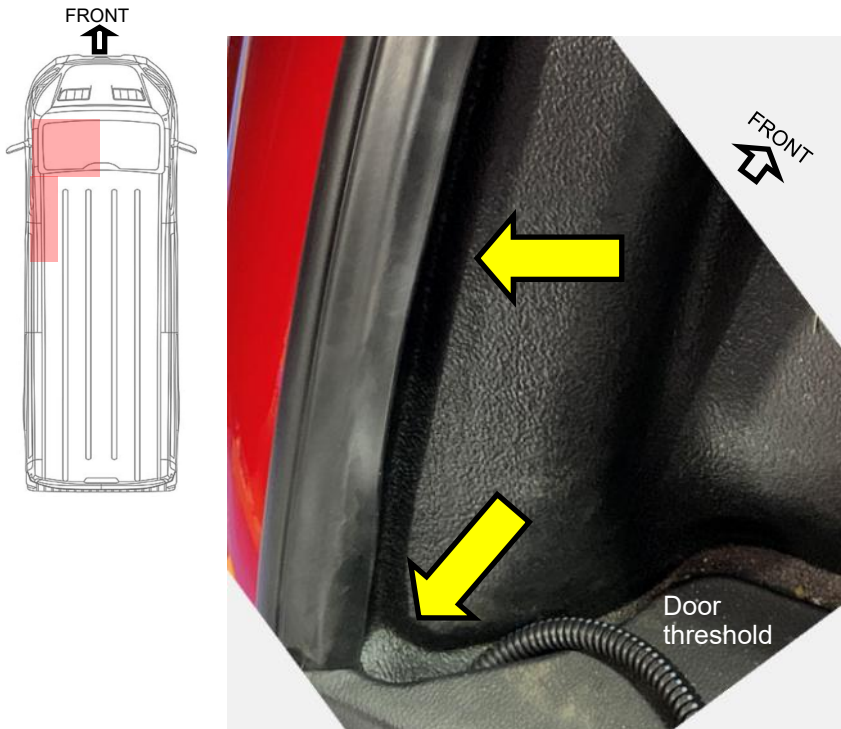

- The floor panel is replaced and the routing of the loom continues under the door threshold.

Step 7A-23. Installation Under the Door Threshold

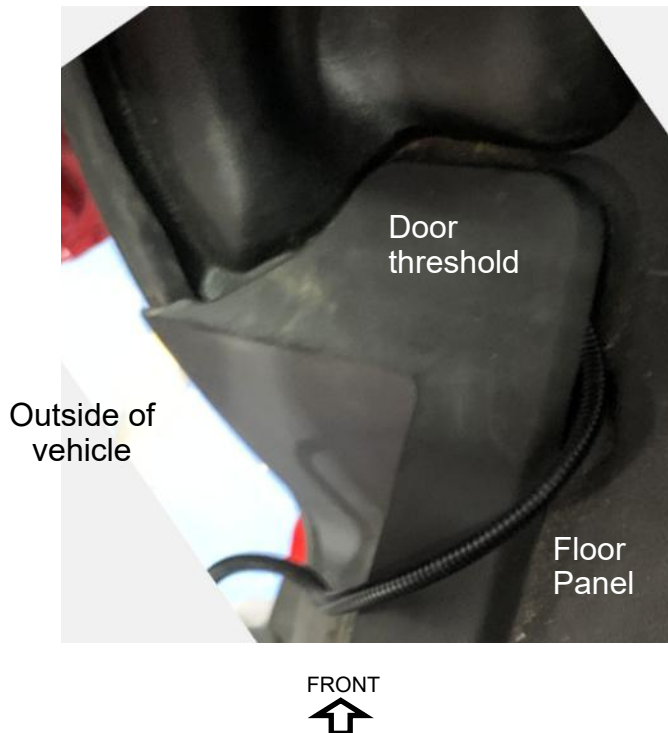

- The remote loom continues along under the edge of the door threshold toward the driver seat base.

Section 7A: Vehicle Interface For Non-67C Application [KITS 66007 and ±66221]

Step 7A-24. Routing of Remote Wire Towards Seat

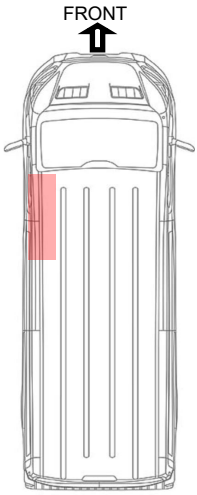

- Routing of the loom continues under the door threshold until it reaches the driver seat base.

Step 7A-25. Installation under Seat Base Flange



- A plastic trim tool is used to assist and to push the remote wire into space beneath the edge of the driver seat base.

Section 7A: Vehicle Interface For Non-67C Application [KITS 66007 and ±66221]

Step 7A-26. Routing of Remote Wire along Seat

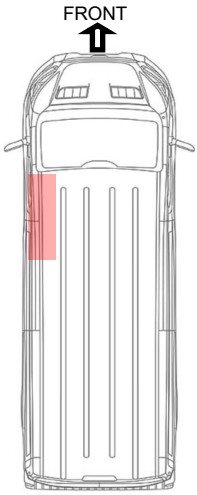

- The wire then goes along the street side edge of the driver seat base.
- Stuff it beneath the seat base flange to secure and hide the wire/corrugated loom.

Step 7A-27. Remote Wire Routing behind Driver Seat

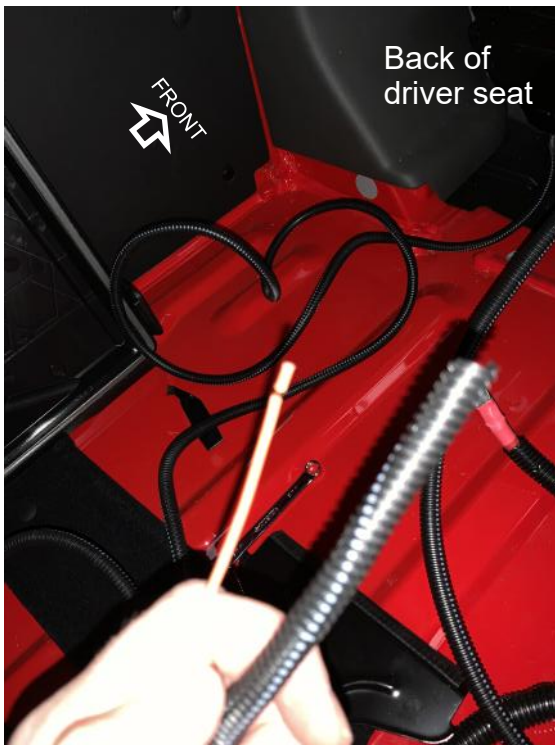
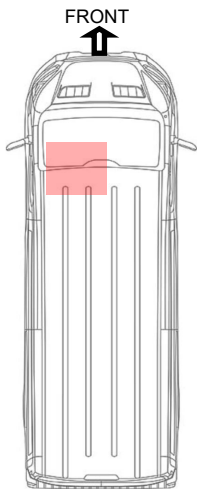

- The remote wire loom exits the back of the seat base and will have extra length.
- This will be trimmed at a later step.
- Two Cables and one Orange wire will be ready for following connections.

Section 7B: Vehicle Interface For 67C Application (*62046 AND 60331)

Step 7B-1. Accessing the 43-way Connector Behind Glove Box

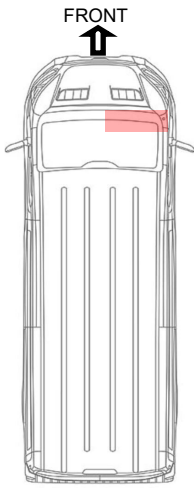

Section 7B Key: If two “WIRE” numbers: Use WIRE “#(y)” for KIT 62046 and “[y]” for KIT 60331. If one “WIRE” number, both use same wire number.

- The Ford Transit with the 67C option package utilizes some of the existing electrical circuitry in the vehicle.
- It is behind the glove box access door.
- The passenger door will need to be opened.

Step 7B-2. Glove Box Removal

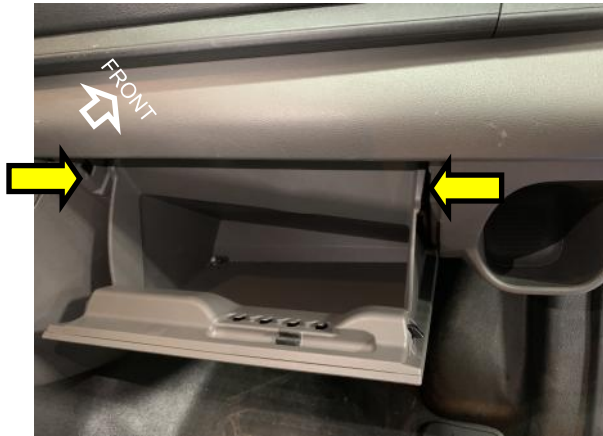

- Empty the glove box.
- There are release latches/stops on both sides of the glovebox back surface (see arrows).
- Press these stops inward to release the glove box so that it drops toward the floor.

Step 7B-3. Access Door Removal



- There is another access door that can be removed in the cup holder by the passenger knee bolster.
- This can be pulled out by the top handle and rotated downward and out.

60331

62046

Section 7B: Vehicle Interface For 67C Application (*62046 AND 60331)

Step 7B-4. 67C Orange Remote Wire Route planning

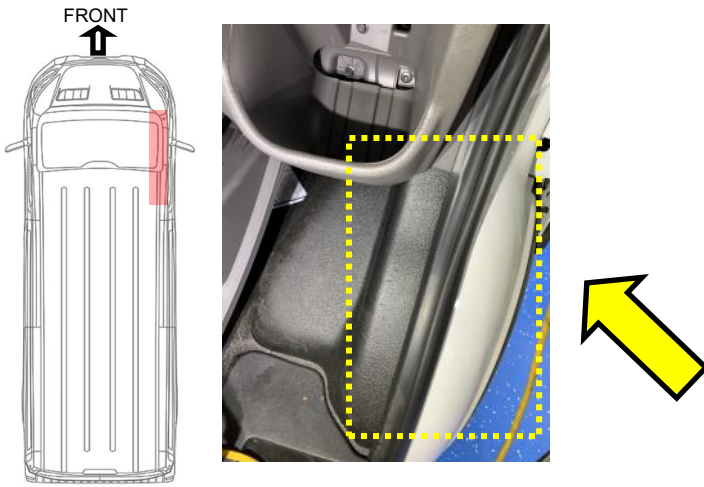

- The **WIRE #(8) [11]** orange remote wire loom will be hidden under this doorway trim.
- But first it must be pushed up into the cavity behind the dashboard. Alternately – it may be brought down from behind the glove box and tucked behind the knee panel and then doorway trim.

Step 7B-5. 67C Orange Remote Wire Route planning

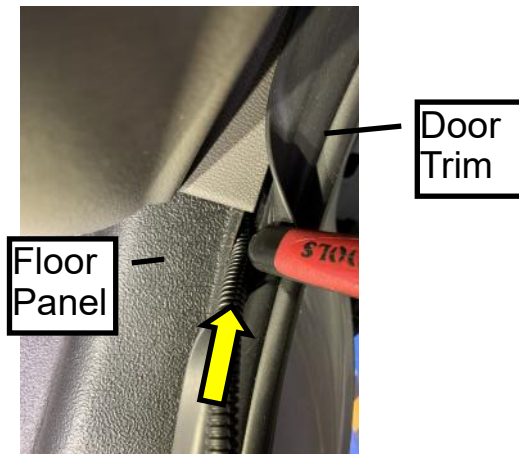

- Pull away the door trim and floor panel enough to be able to push the wire loom upward and behind the dashboard.
- The corrugate loom should be able to be pushed up about 16”.

Step 7B-6. 67C Orange Remote Wire Routing

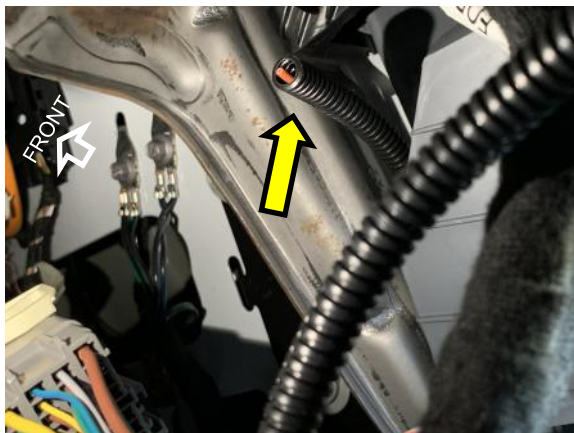

- Using the push up from below method, looking in through the glove box port [to the right], towards the curbside fender sheet metal, the **WIRE #(8) [11]** orange wire corrugate can be seen.
- Pull the wire and corrugate while feeding in another ~18”.
- The **WIRE #(8) [11]** Orange Remote wire may also be routed in through the glovebox and wedged into place under the glovebox trim if preferred.

60331

62046

Section 7B: Vehicle Interface For 67C Application (*62046 AND 60331)

Step 7B-7. Connecting to 43-Way Upfitter Connector

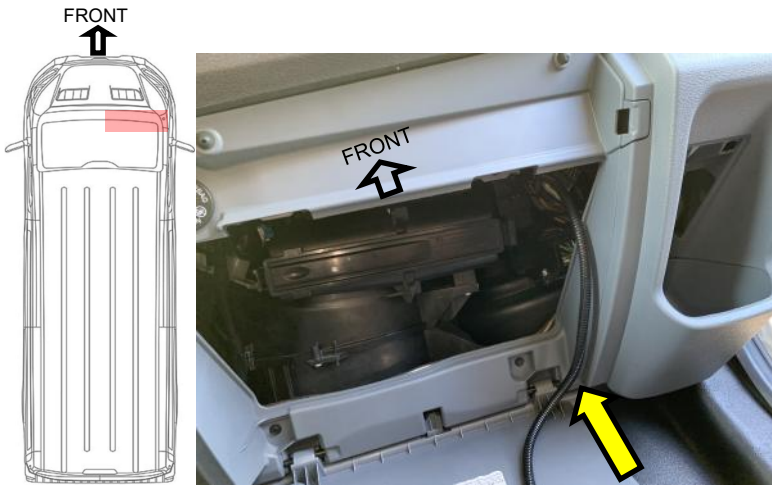

- The **WIRE #(8) [11]** corrugate Orange wire loom is shown here pulled out and ready for next step.

Step 7B-8. Strip Orange wire



- The end to the **WIRE #(8) [11]** Orange wire will need to be stripped so that it can be joined to the wire in the 67C Up-fitter's connector.

Step 7B-9. Identifying AUX 1 Switch wire on connector



60331
62046

- The upfitter connector will be delivered with the vehicle. It may be in the glove box in a bag.
- This 43 way connector is called the "High Specification Vehicle Interface"

Section 7B: Vehicle Interface For 67C Application (*62046 AND 60331)

Step 7B-10. Identifying AUX 1 Switch wire on connector

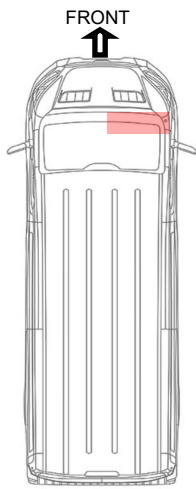

High Specification Vehicle Interface Connector

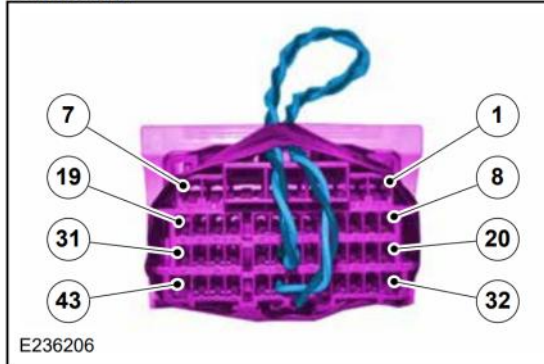

- This is a photo of the blank connector for illustration purposes.
- Pin 1 is the Switched Upfitter Output #1.
- Locate Pin 1 on the connector itself to verify wire color
- This wire should be a larger **16AWG GREEN** wire in the harness.

Step 7B-11. Strip the AUX 1 Green Wire



- This **16AWG GREEN** wire will be stripped so that it may be butt spliced to the **WIRE #(8) [11]** Orange remote wire.

Step 7B-12. Connecting Green and Orange wires

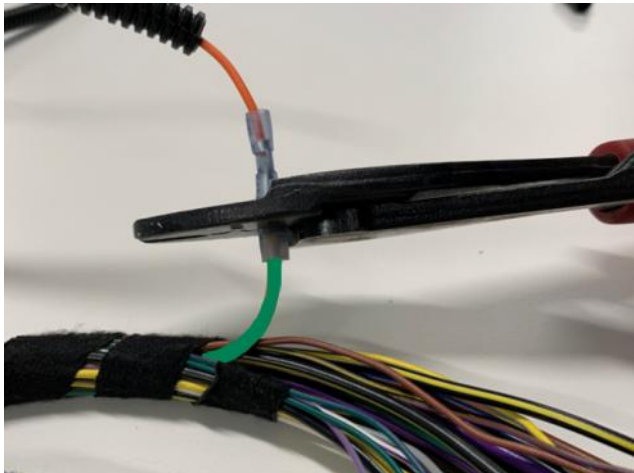

- Insert the **WIRE #(8) [11]** Orange wire into butt splice crimp already on the Green 67C connector wire and crimp firmly.

60331

62046

Section 7B: Vehicle Interface For 67C Application (*62046 AND 60331)

Step 7B-13. Sealing joint between Green and Orange wires

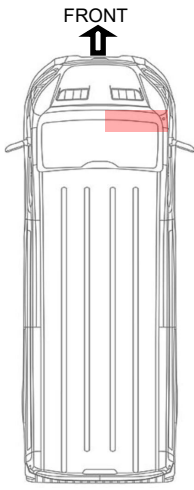

- The crimp insulation can be shrunk if heat gun is available.

Step 7B-14. Upfitter Connector Preparation



- Remove blank High Specification Vehicle Interface connector and place in safe location for future use if necessary.

Step 7B-15. Upfitter Connector Preparation



- The remaining side of the harness will accept the prepared upfitter connector and its harness.

60331

62046

Section 7B: Vehicle Interface For 67C Application (*62046 AND 60331)

Step 7B-16. Upfitter Connector Connection

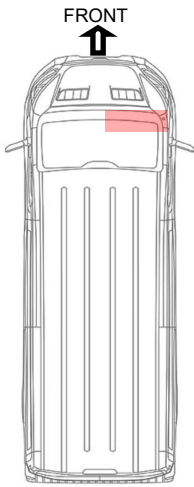

- Plug in the harness and make sure the lock is rotated and snapped in place to ensure the connectors are fully seated into each other.

Step 7B-17. Change Auxiliary Fuse Position

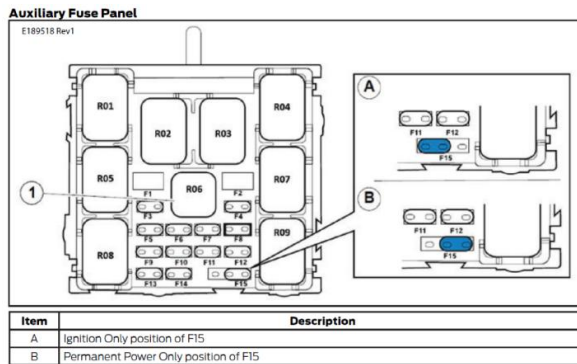

- [NOTE: AT THIS POINT REFER TO FIGURE 5-5: OPTION 67C AUXILIARY FUSE PANEL—BE SURE THE FUSE IS IN POSITION “B”.](#)

Step 7B-18. Completed Upfitter Connector Stowage

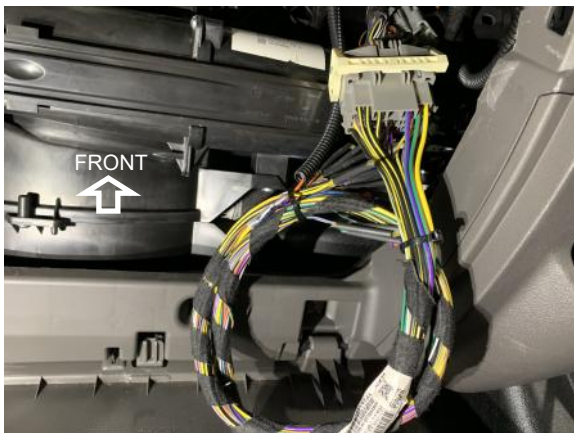

- Use Ty wraps to neatly bundle the harness to stow out of the way behind the cupholder area.

60331
62046

Section 7B: Vehicle Interface For 67C Application (*62046 AND 60331)

Step 7B-19. Completed Upfitter Connector Stowage

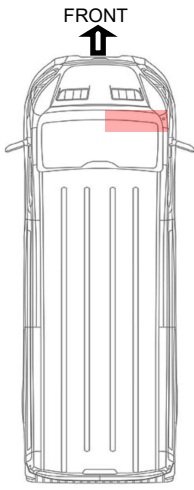

- The harness can be tie wrapped onto any solid point.
- Be sure it will not interfere with the glove box when it is installed.

Step 7B-20. Re-Installation of Glove Box



- Install the glove box and cup holder access panel.

Step 7B-21. Routing of the Orange Remote wire

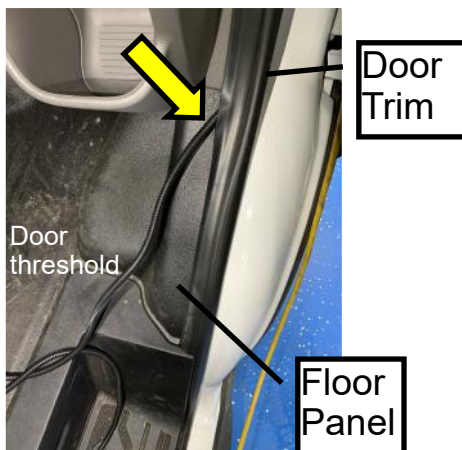
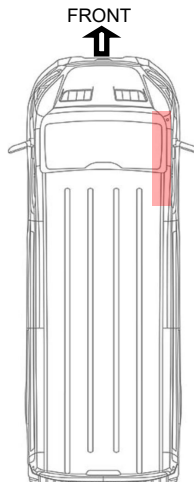

60331
62046

- The **WIRE #(8) [11]** orange remote wire loom [corrugate shield] will compress under the door trim.
- The floor panel should be returned in its position under the edge of the trim after the loom is pushed in.

Section 7B: Vehicle Interface For 67C Application (*62046 AND 60331)

Step 7B-22. Routing of the Orange Remote wire

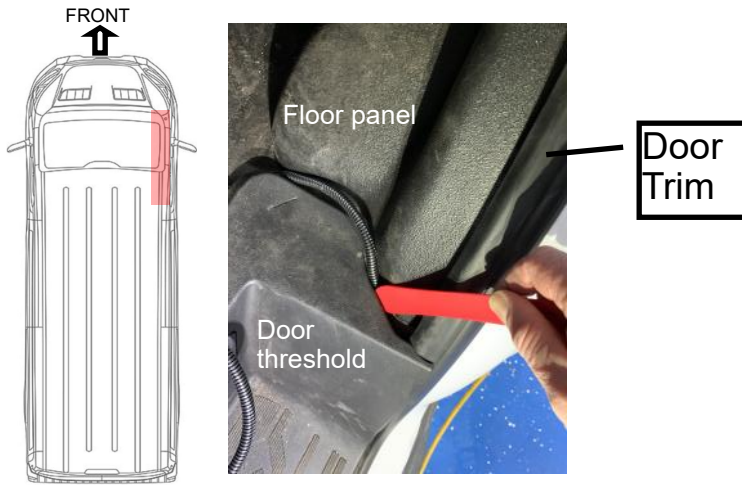

- Use the plastic trim tool to carefully guide the **WIRE #(8) [11]** orange wire loom underneath the door threshold trim.

Step 7B-23. Routing of the Orange Remote wire beneath threshold



- The loom will continue to be pushed beneath the door threshold trim until it meets the bottom flange of the passenger seat base.

Step 7B-24. Routing of the Orange Remote wire beneath seat mount



- A plastic trim tool is used to assist and to push the remote wire into space beneath the edge of the drivers seat base.
- The wire then goes along the curb side edge of the passengers seat base.
- Stuff it beneath the seat base flange to secure and hide the wire/corrugated loom.

60331

62046

Section 7B: Vehicle Interface For 67C Application (*62046 AND 60331)

Step 7B-25. Routing of the Orange Remote wire behind seat mount



- When the **WIRE #(8) [11]** orange wire loom reaches the end of the seat flange, it can then continue behind the seat.
- The **WIRE #(8) [11]** orange wire can be tucked underneath the floor covering in any manner to keep it shielded from any damage.

Step 7B-26. Routing of the Orange Remote wire behind seating

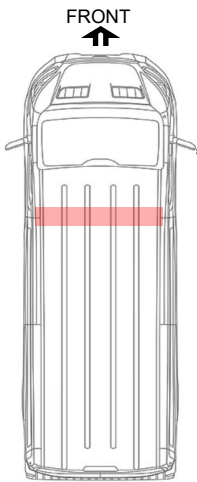

- The **WIRE #*8 [11]** orange wire can also be continued to be tucked beneath the passenger's seat base flange.

Step 7B-27. Routing of the Orange Remote wire to the Inverter area



- The **WIRE #(8) [11]** orange wire loom will be routed to the area behind the driver's seat to meet the inverter when it is installed.
- **WIRE #2 & WIRE #(5) [7]** will also be there waiting for the next step of inverter installation.

60331

62046

Section 8: Sales Order Drawing Discussion:

One or Two Auxiliary Battery Installation

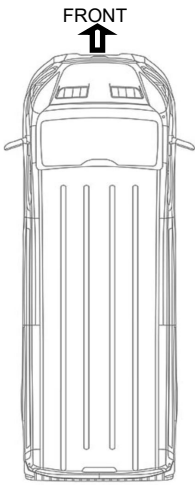

Sales Order Drawing :

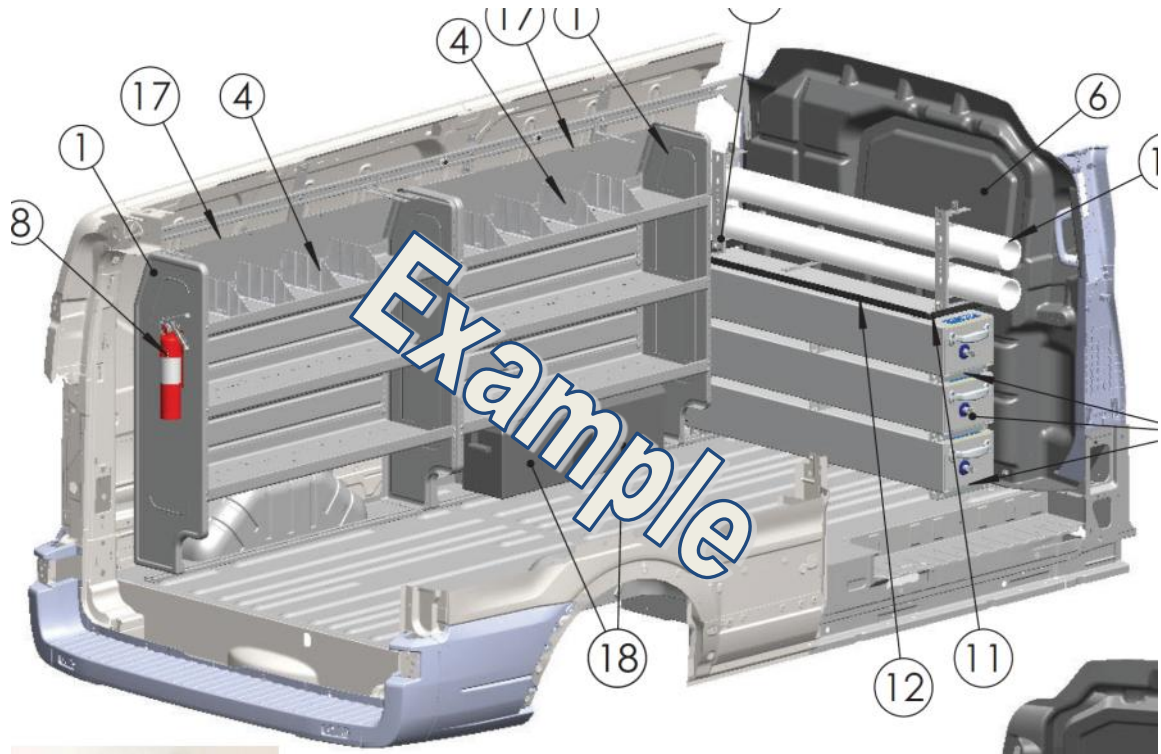

Important:

- 1) The Sales order drawing, in accompaniment with this instruction, is necessary to determine placement of the inverter and the auxiliary batteries within the limits of the cabling and out of zones prohibited due to safety considerations (Fuel, HV, etc.).
- 2) This installation document covers the steps of installation and suggested locations, but cannot cover exact placement of key components like the contactors, fuses and auxiliary batteries due to specific customization of the structures (shelves, cabinets, etc.) in the cargo area.
- 3) The instructions herein show approximate placement, which is mainly dictated by the length of the cables. Variations are OK as long as :
 - Proposed placement does not place components directly in area where objects may fall on the inverter or any of the cable terminals, *and*
 - There is full coverage of all connections and proper fitment of batteries and other components mounted to the vehicle, *and*
 - Fastening guidelines are followed with proper hardware appropriate for mounting of components without environmental or vibration damage.
- **SUMMARY:** Usually the Sales order drawing does not give specific locations of some of the key components for the inverter system, but installer is still responsible for proper installation with the proper location and safety considerations, mounting hardware and tightening torques when required.

Section 9A: Install/mount Contactor + Fuse Holders [KIT 66007 and 60331]

Step 9A-1. Pre-planning for AUX Battery Boxes



Caution: There are areas on the vehicle that upfitters are not permitted to put holes in the floor. Please be aware and pre-plan to avoid these areas.

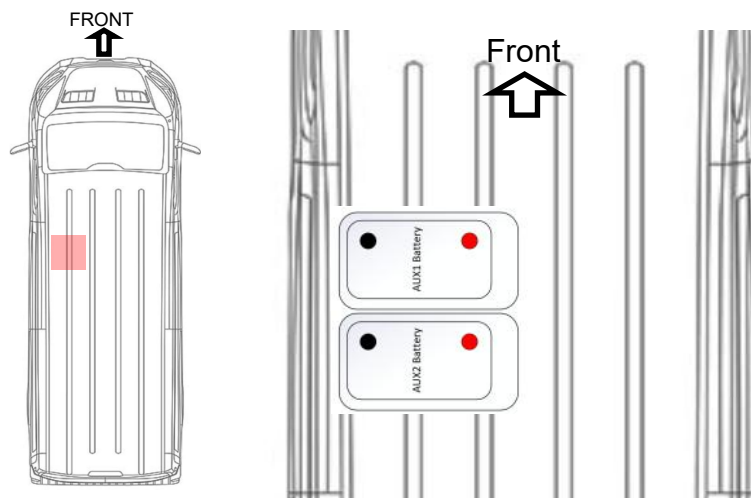

- The battery boxes position should be preplanned based upon the location of the contactor and fusing as well as the lengths of the wires.
- Generally the batteries will be oriented side to side with a short edge toward the side wall of the vehicle.

- Take care that the batteries do not block the fusing when they are placed.
- Some examples of relative placement are shown to the below:

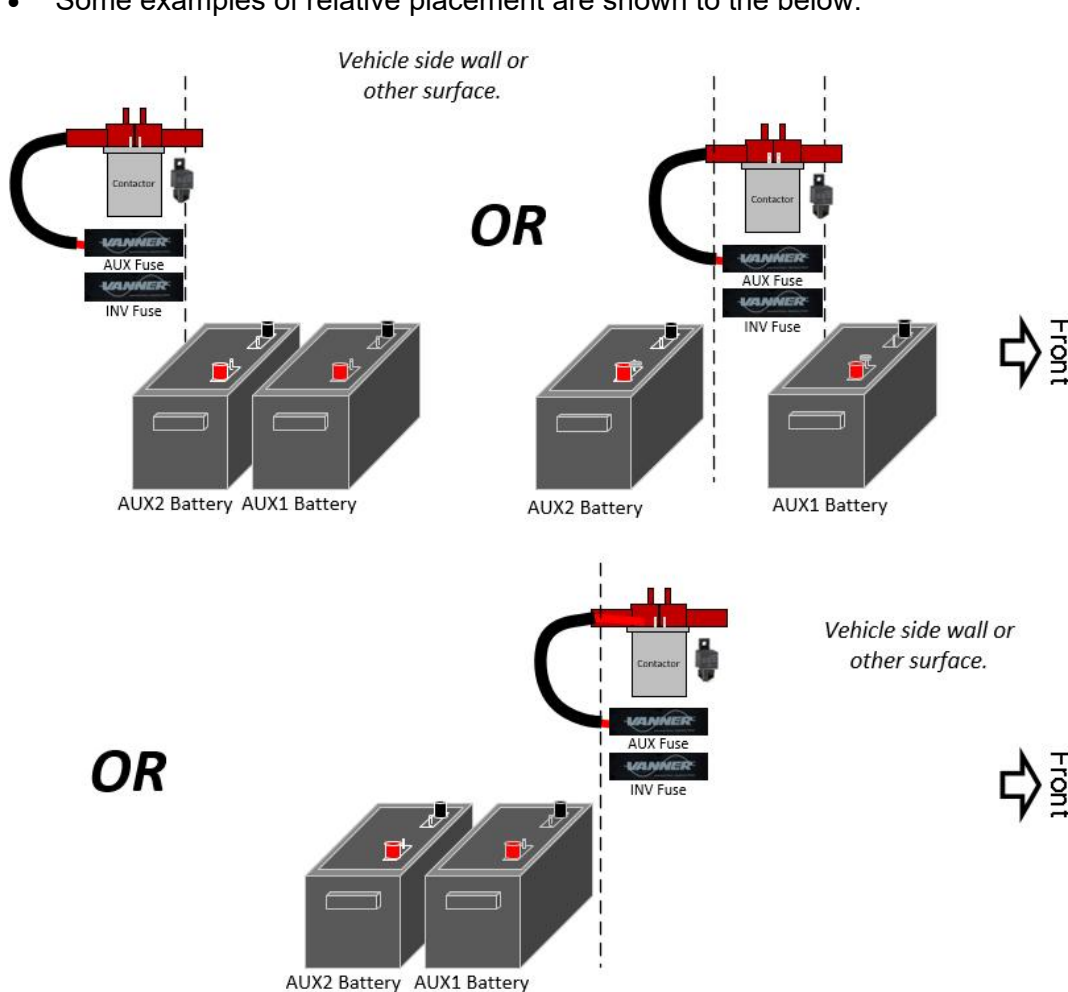

Diagram 9A-1: KIT 66007 2 AUX Battery Arrangements

66007

60331

- Mounting the battery boxes is one of the most variable activities in the installation of the Auxiliary batteries.
- Essentially the batteries will need to be fastened solidly to the floor in positions that allow the wire lengths to be used along with easy access to the fuses.
- There are several scenarios in which the batteries will be installed. The floor surface may be covered or bare, and there may also be shelf mounts to straddle in the installation area.
- For the purposes of this instruction, the batteries will be mounted to slide rails in the cargo area floor.

Section 9A: Install/mount Contactor + Fuse Holders [KIT 66007 and 60331]

Step 9A-2. Fasten WIRE#2 to the Contactor



Caution: There will be no fuse installed at this point

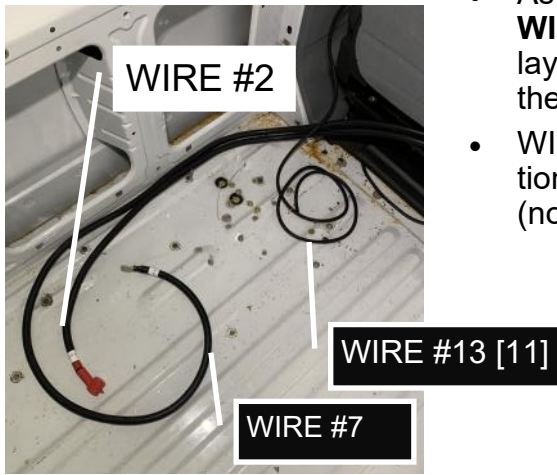
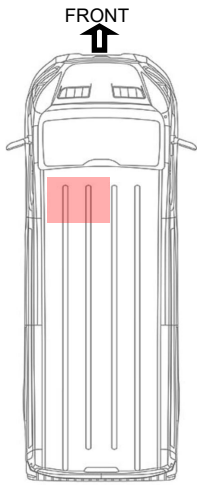

- As mentioned after Step 7A-27 or 7B-27 , **WIRE #7**, **WIRE #2** and **WIRE #13** (orange remote wire) will be laying behind the seat in the area on the cab side of the partition.
- WIRE #7 and WIRE #2 will be brought past the partition to the Auxiliary Batteries and the related circuitry (not shown in this photo).

Section 9A Key: If two “WIRE” numbers: Use WIRE “#y” for KIT 66007 and “[y]” for KIT 60331. If one “WIRE” number, both use same wire number.

Step 9A-3. Contactor Placement



- Mount the contactor using two self-tapping sheet metal screws. The mount should be firm, but avoid over torquing. Use FAS0629 (Ref. NO.:13) torqued to 3Nm [+/- 0.5Nm] (27lb.in). 66007
- The contactor will be mounted to a solid surface in the cargo area. It can be mounted to the inside supports for the transit exterior walls or cabinetry which will be around the Auxiliary [AUX] batteries. 60331
- NOTE: Make sure access is not impeded by the installed batteries.

Step 9A-4. Alternate Contactor Mounting Hardware

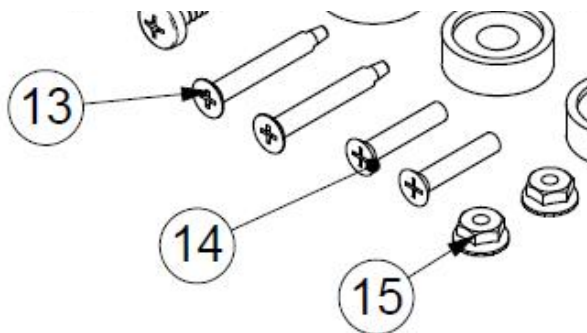
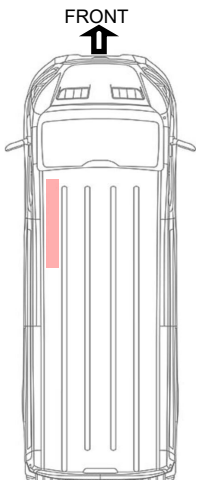

- If the contactor is being mounted on a cabinet, please use Fasteners Ref. NO.:14 and 15 to install through pre-drilled sheet metal holes.

Section 9A: Install/mount Contactor + Fuse Holders [KIT 66007 and 60331]

Step 9A-5. Install Terminal Insulator

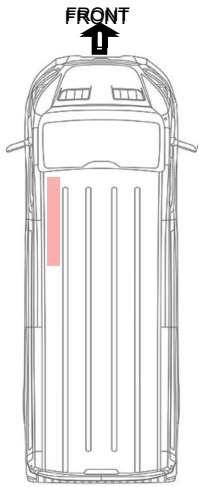

Caution: The Terminal insulators are important to install to avoid accidental connections to contact terminals.

- Please push **WIRE #2** into the RED TERMINAL INSULATOR.

Step 9A-6. Prepare VSS-VC Harness

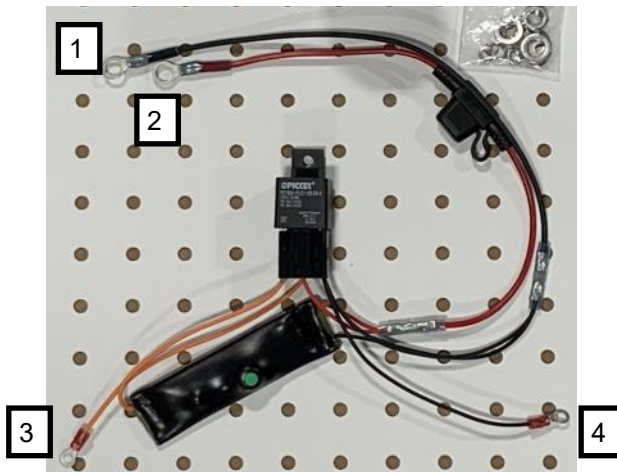

- The VSS-VC Harness consists of:
 1. Negative AUX 1 Battery wire (BLK - Ring Terminal)
 2. Positive Contactor wire (RED - Ring Terminal)
 3. Contactor Coil (+) wire (ORG- Small Terminal)
 4. Contactor Coil (-) wire (BLK - Small Ring Terminal)

66007

60331

Step 9A-7. Wire #2 and VSS-VC Red Wire Routing

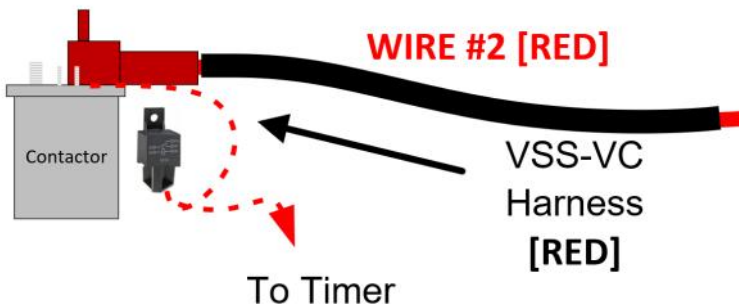

- Along with **WIRE #2**, the **VSS-VC RED - Ring Terminal wire** will be connected to the contactor terminal as shown in the diagram to the left.

Section 9A: Install/mount Contactor + Fuse Holders [KIT 66007 and 60331]

Step 9A-8. WIRE #2 Routing

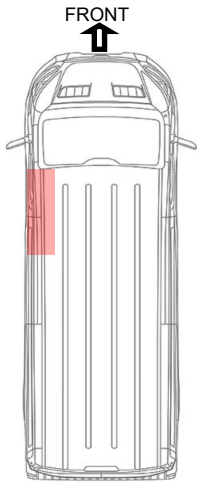

- Pull back the RED TERMINAL INSULATOR on **WIRE #2** and place the lug onto the CONTACTOR Post.

Step 9A-9. Wire #2 and VSS-VC Red Wire Routing



66007

- Install the VSS-VC Harness red wire 5/16 Ring terminal (See diagram in Step 9-7) on top of **WIRE #2** on the CONTACTOR terminal.

60331

Step 9A-10. Fasten Wire #2 and VSS-VC Red Wire

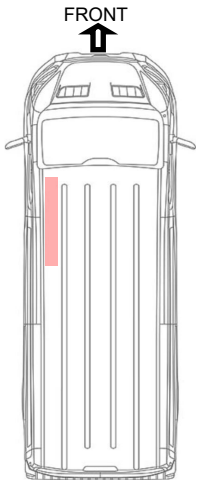

- 1 Fasten the washers and nut (Ref. NO.:21). The torque will be: 10.2Nm [+/- 1.1Nm] (~90 lb.in).

Section 9A: Install/mount Contactor + Fuse Holders [KIT 66007 and 60331]

Step 9A-11. Planning Placement for AUX and INV Fuse Holders

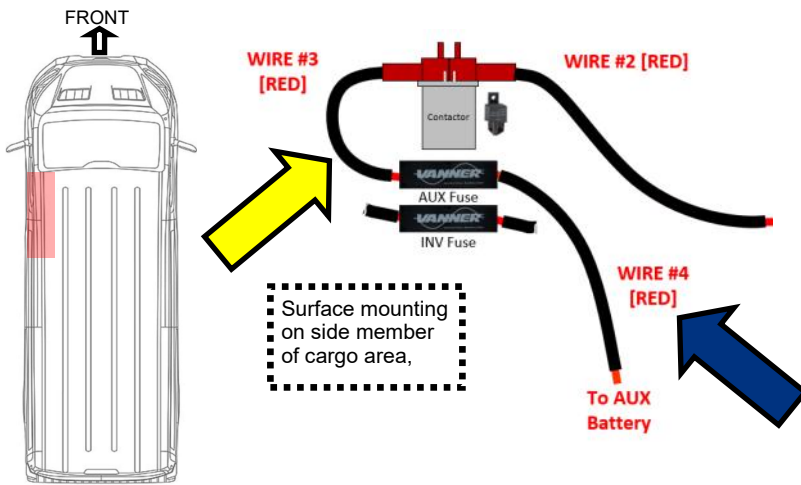

- Below or nearby the contactor, the AUX Fuse will be mounted.
- The **WIRE #3** (See Yellow Arrow) will be very short, forcing the mounting location of the AUX fuse holder very near to the contactor.
- The key here is the mounting location of the AUX Batteries - the **WIRE #4** (See Blue Arrow) length is limited in order to reduce voltage drop - the contactor must be planned to be very near the AUX fuse holder and the AUX batteries.

Step 9A-12. Preparing WIRE #3 with Red Terminal Insulator



66007

- Push the RED TERMINAL INSULATOR onto any end of **WIRE #3**

60331

Step 9A-13. Installing and fastening WIRE #3

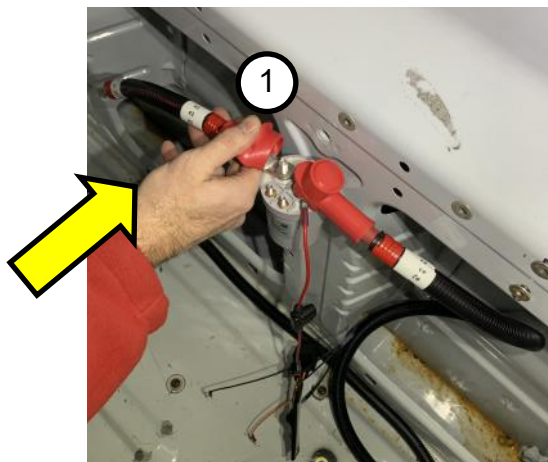

- Install **WIRE#3** onto the left-most post.
 - Fasten the washers and nut (Ref. NO.:21).
- ① The torque will be: 10.2Nm [+/- 1.1Nm] (~90 lb.in).

Section 9A: Install/mount Contactor + Fuse Holders [KIT 66007 and 60331]

Step 9A-14. Attaching VSS-VC Harnessing to Contactor

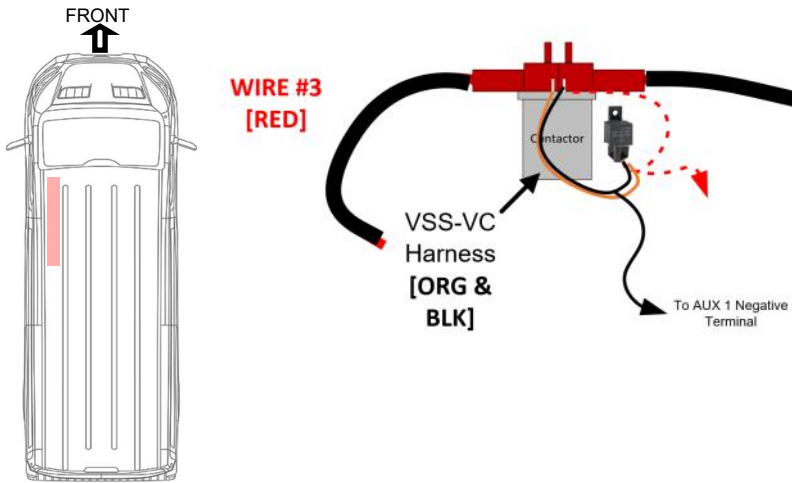

- Fasten the ORANGE VSS-VC Wire with “#10” Ring Terminal to the contactor’s positive coil terminal.
- Fasten the “#10” BLACK VSS-VC ring terminal to the contactor’s negative coil terminal.

Step 9A-15. Attaching VSS-VC Harnessing to Contactor

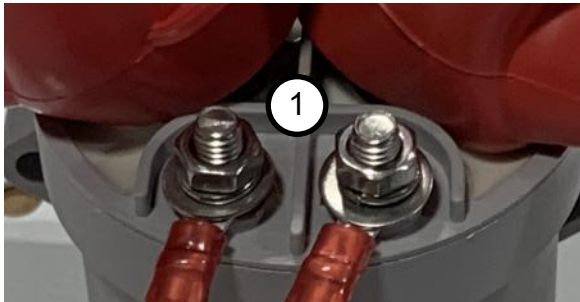

- Fasten the washers and nut with a 3/8” driver.
- ① The torque will be: 2.5Nm [+/- 0.8Nm] (~22.5 lb.in).

Step 9A-16. Remote Wire Routing



- The VSS-VC Voltage controlled relay for the contactor will now be connected to the contactor.

Section 9A: Install/mount Contactor + Fuse Holders [KIT 66007 and 60331]

Step 9A-17. VSS-VC controller Wire Routing

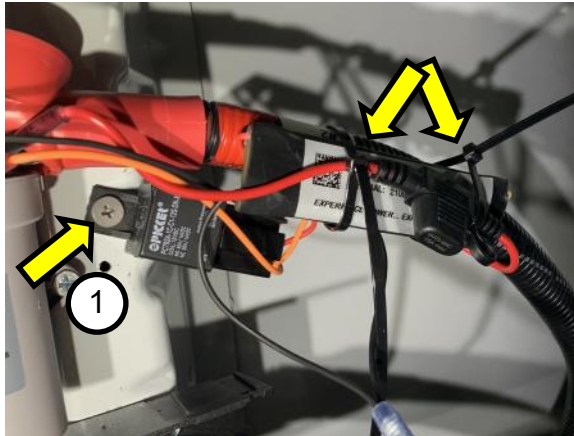
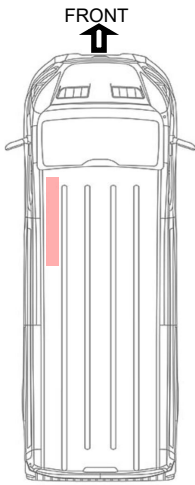

- In this example, the relay is mounted next to the Contactor and the VCC-VS harnessing is wire tied to the **WIRE # 2** [see Yellow Arrows]
- ① Use FAS0148 (Ref. NO.:11) and lightly torque to 3Nm [+/- 0.5Nm] (27lb.in).

Step 9A-18. Mounting AUX Fuse Holder very near Contactor



- Be sure **WIRE #3** can reach the Fuse holder terminal from its attachment on the contactor.
- Use FAS0360 (Ref. NO.:12) self tapping screws to mount the AUX Fuse holder firmly.
- Connect **WIRE #3** and finger tighten the lug to the terminal with the 1/2" nut and washers.
- The fuse will be put in near the end of the procedure for safety.

66007

60331

Step 9A-19. Alternate AUX & INV Fuse Holder Mounting Hardware

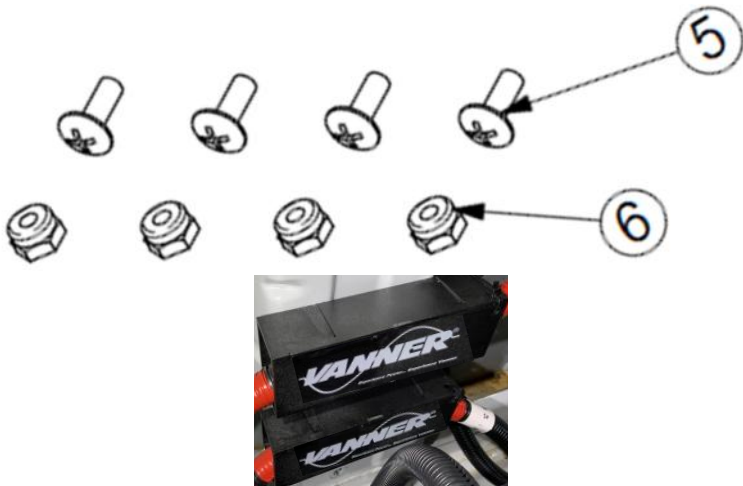

Alternative mounting option:

- If installing on a sheet metal shelving unit or partition, mount the **AUX** and **INV** fuse holders with 10-24 screws FAS0025 (Ref. NO. : 5) and 10-24 Ny-lock flange nuts FAS0029.(Ref. NO. :6).

Section 9A: Install/mount Contactor + Fuse Holders [KIT 66007 and 60331]

Step 9A-20. INV Fuse Holder Mounting

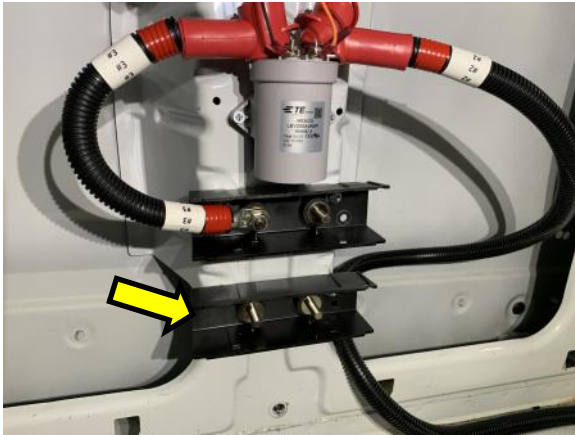

- The inverter (INV) fuse holder should be conveniently mounted near the AUX Fuse holder. Use FAS0360 (Ref. NO.:12) self tapping screws to mount the INV Fuse holder firmly.
- They are not directly connected but putting them in the same area allows planning for access later.
- NOTE: These should not be installed behind the AUX batteries, or else the batteries will need to be moved to access the fuses.

Step 9A-21. Remote Wire Routing



66007

- **WIRE #4** (1 of 2) Can be fastened onto the other terminal of the AUX Fuse holder (See Yellow Arrow) and the fastener finger tightened (Ref. NO.: 18).
- **WIRE #4** will go to an AUX 2 Battery Terminal as shown in Diagram 4-1.
- Again no fuse will be installed at this time for safety.

60331

Section 9B: Install/mount Fuse Holders [KIT #66221 & *62046]

Step 9B-1. Pre-planning for 1 AUX Battery Box



Caution: There are areas on the vehicle that upfitters are not permitted to put holes in the floor. Please be aware and pre-plan to avoid these areas.

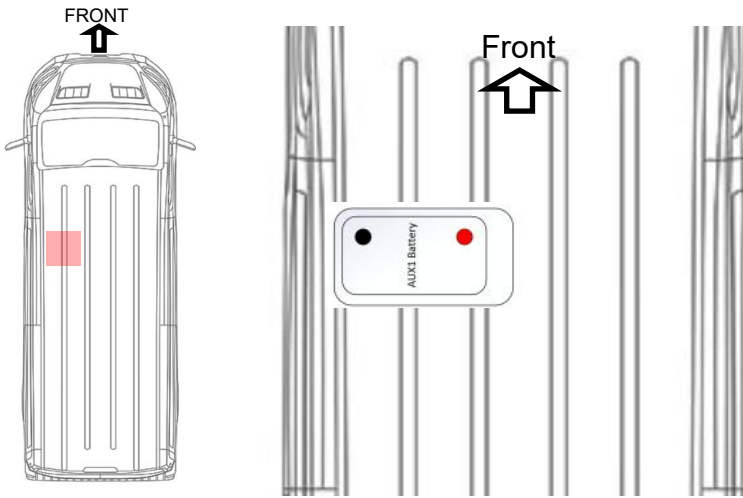

- The battery box position should be pre-planned based upon the location of the contactor and fusing as well as the lengths of the wires.
- Generally the battery will be oriented side to side with a short edge toward the side wall of the vehicle.

- Take care that the battery does not block the fusing when it is placed.
- Some examples of relative placement are shown to the below:

Vehicle side wall or other surface.

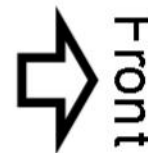
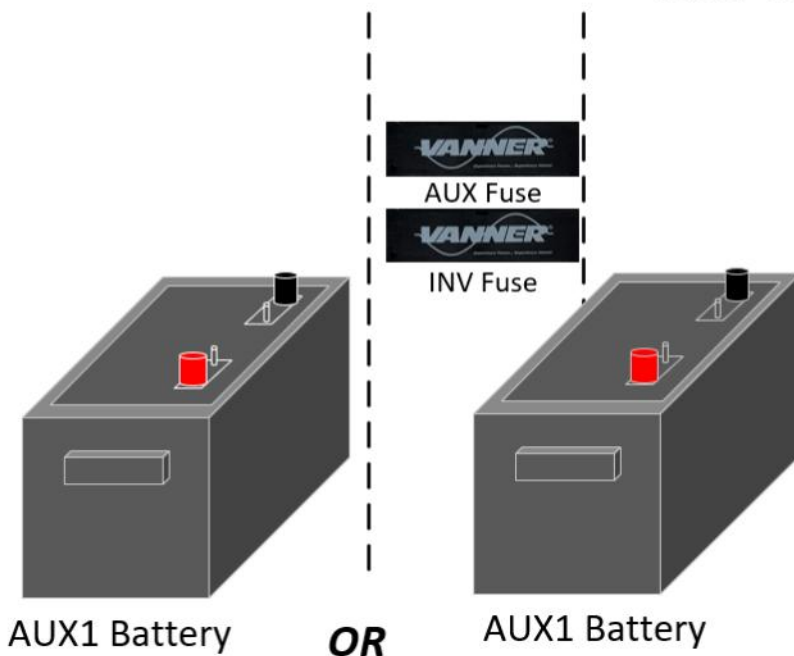

- Mounting the battery box is one of the most variable activities in the installation of the Auxiliary batteries.
- Essentially the battery will need to be fastened solidly to the floor in a position that allow the wire lengths to be used along with easy access to the fuses.
- There are several scenarios in which the batteries will be installed. The floor surface may be covered or bare, and there may also be shelf mounts to straddle in the installation area.
- For the purposes of this instruction, the batteries will be mounted using plusnuts directly installed in the cargo area floor.

Section 9B: Install/mount Fuse Holders [KIT #66221 & *62046]

Step 9B-2. Fasten WIRE#2 to the AUX Fuse Holder



Caution: There will be no fuse installed at this point

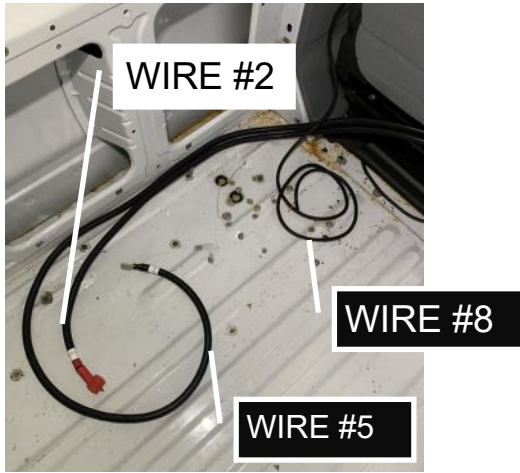
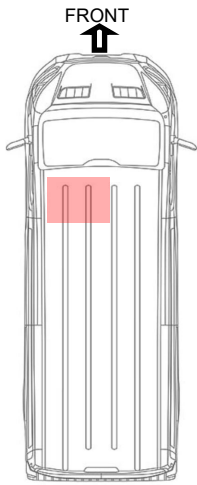

- After Steps 7A-27 [for 66221] and 7B-27 [for 62046], **WIRE #5** and **WIRE #2** and **WIRE #8** (orange remote wire) will be laying behind the seat in the area on the cab side of the partition.
- **WIRE #5** and **WIRE #2** will be brought past the partition to the Auxiliary Battery and the related circuitry (not shown in this photo).

Step 9B-3. Planning Placement

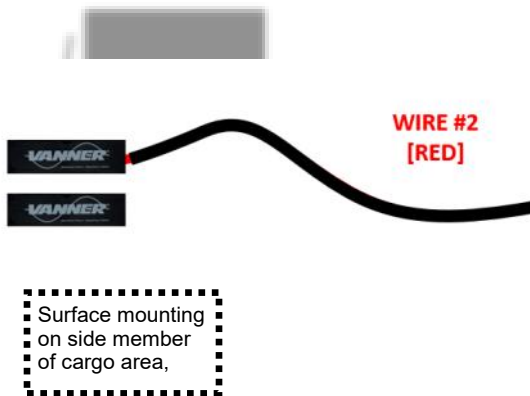

- The fuse holders will be mounted onto a solid surface in the cargo area. They can be mounted to the inside supports for the Transit exterior walls or cabinetry which will be around the Auxiliary [AUX] batteries.
- NOTE: Make sure fuse access is not impeded by the installed batteries. The fuse holders should not be installed behind the AUX batteries, or else the batteries will need to be removed in case of servicing.

Step 9B-4. Cable Routing

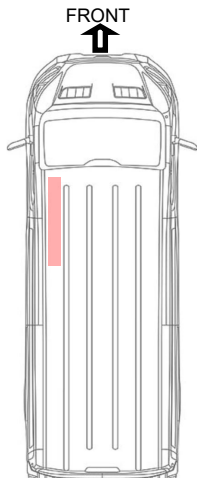

- Use FAS0360 (Ref. NO.:12) self tapping screws to mount the AUX Fuse holder firmly.
- Connect **WIRE #2** and finger tighten the lug to the terminal with the 1/2" nut and washers.
- The fuse will be put in near the end of the procedure for safety.

Section 9B: Install/mount Fuse Holders [KIT ±66221 & *62046]

Step 9B-5. Alternate AUX & INV Fuse Holder Mounting Hardware

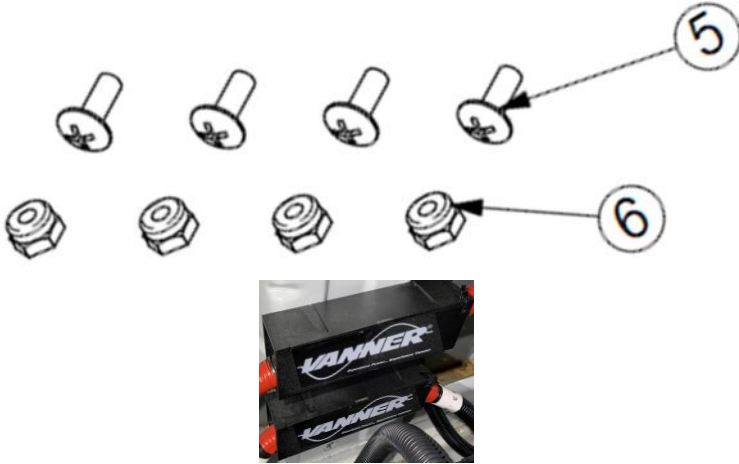

Alternative mounting option:

- If installing on a sheet metal shelving unit or partition, mount the **AUX and INV** fuse holders with 10-24 screws FAS0025 (Ref. NO. : 5) and 10-24 Ny-lock flange nuts FAS0029.(Ref. NO. :6).

Step 9B-6. AUX and INV Fuse holder Placement

FRONT
↑



- All of the cables can be attached to the terminals of the fuseholders after locating Auxiliary battery box.
- The steps below will show suggested steps.

Step 9B-7. Cable Lengths to Auxiliary Battery Box

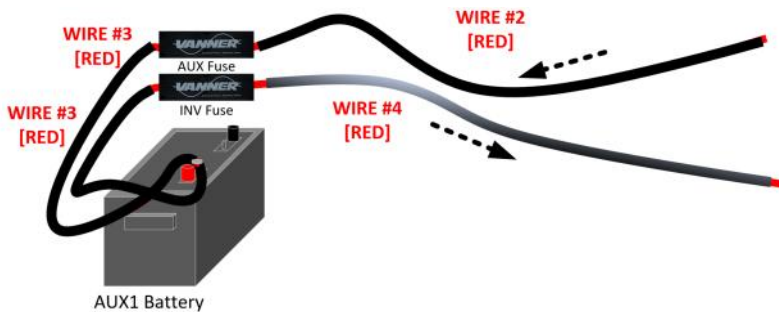

- Again, plan to have the auxiliary battery box mounted within range of the supplied KIT ±66221 & *62046 cables.

Section 10: Install/mount AUX batteries– Plus Nuts Mounting:

Step 10-1. Battery Box Preparation

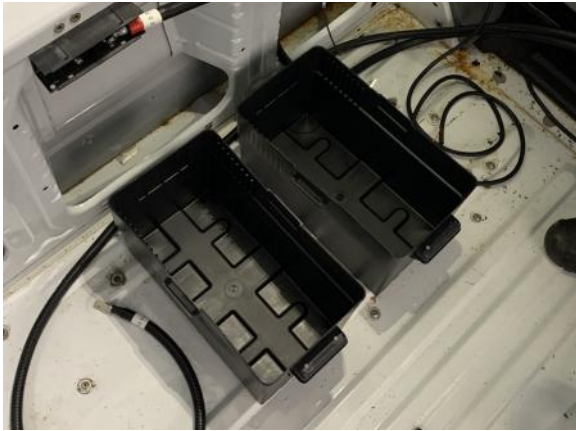
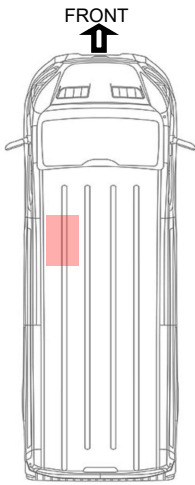

- NOTE: One or Two AUX Batteries can be placed using this method.
- Place the battery box(es) in the desired location to be sure the location of the system is near enough to the inverter and ensures optimal placement next to the fuse holders.
- Battery Box(es) will be solidly mounted by plus-nuts and screws in the vehicle floor.

Step 10-2. Marking the positions of holes



- The battery box(es) are put upon the floor and holes are marked in the bottom of the battery box via marker.
- The holes should line up with the valleys on the floor profile (straddling the ridges in the floor).
- Mark the desired positions of the mounting screws.

Step 10-3. Remote Wire Routing



- The boxes are marked and ready to drill.

Section 10: Install/mount AUX batteries– Plusnuts Mounting:

Step 10-4. Battery Box Preparation

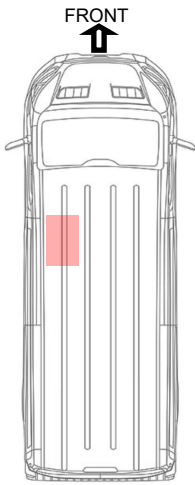

- After the hole locations are marked, the box is put onto a safe drilling surface and a 1/2" hole is drilled at four locations on each boxes.
- The boxes again are placed in their intended positions and the positions of the holes on the floor are marked through the holes in the bottom of the battery box (be sure to read Section 8 about position planning of the boxes).

Step 10-5. Battery Box mounting holes and plusnut installation



- Once again remove the boxes and use a 1/2" drill to put holes into the floor to receive the plusnuts.
- If there is a floor covering, 1" holes will need to be put into just the floor covering to allow for the plusnut to be installed flush to the floor surface.
- Utilize the plus nut gun to install the plus nuts (installation instructions are not supplied in this instruction– please use plusnut gun manufacturer's instructions).

Step 10-6. Battery Box mounting holes and plusnut installation

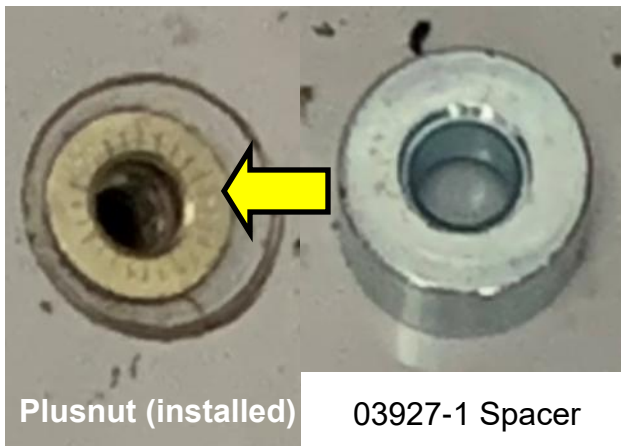

Plusnut (installed)

03927-1 Spacer

- Place 03927-1 spacers over each plus nut. This gives the battery box stability, allowing solid mounting while straddling the ridges in the floor.
- NOTE: For more detailed plusnut installation instructions– [See Appendix 16-B: Plusnut Installation Guide](#)

Section 10: Install/mount AUX batteries– Plusnuts Mounting:

Step 10-7. Battery Box Mounting



NOTE: The battery box straps are important to install for each box to ensure safety.

- Set the battery box in its location. Be sure the Nylon strap is under the box.
- Mount the boxes with four (4) 5/16"-18 x 2" screws FAS0048 (Ref. NO.:4) and four (4) cup flanged washers FAS0833 (Ref. NO.:9) as shown in photo.
- These four screws will be driven into the plusnuts already installed in the vehicle floor.
- Torque the screws down to 15Nm [+/- 1.8Nm] (132lb.in).

Step 10-8. Battery Box Preparation

Vehicle side or shelf wall

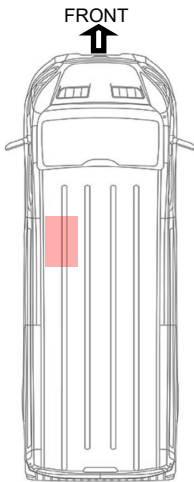

- The batteries are placed into the boxes with the negative terminals closest to the side of the vehicle's cargo area which will have the contactor and/or fuses mounted to it.
- The Battery carry straps may be tucked flat or removed from each battery and stored in extra space of battery box (they are removed in the photo to the left).

Step 10-9. Battery Box bracket

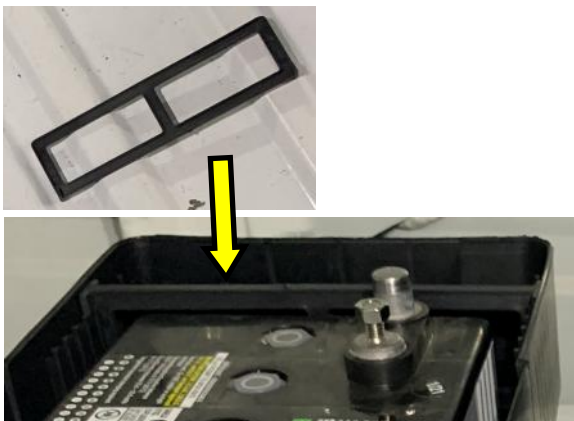

- The adjustment bracket will need to be placed in the ribs on the top inside portion of the opening in the box. This bracket keeps the battery from sliding within the oversized box.
- The straps will be applied around the outside of the battery box in a later step.

Please Note: There may be several different batteries provided for this install. For batteries 70038 and crown battery 79382 use the normal instructions on how to connect the inverter wires. For the Full River Battery (79381) please follow the next 2 pages on how to install the inverter wires to the aux battery.

Product Communication Bulletin – Inverter Cables to Battery

Dear valued partners,

This bulletin follows Deviation-1285 (due to supply shortages of Discover battery). To preempt any confusion, we want to bring awareness to you concerning the attachment points on the blue Full River battery. This communication is because the instructions for the kits have not been changed to account for the differences in terminal posts. Instruction change is a work in progress. There are four points of clarification for this deviation:

1. The Full River battery comes with brass automotive posts and M8 bolts and hardware in the battery's box. When shipped there are no fasteners on the battery.
2. Instead of fastening the cable lugs onto the threaded marine terminals of the Discover batteries, the technician will fasten the cable lug to the battery by putting the bolt through the lugs and then fastening onto the battery.
3. There is a specific order in applying the washers onto the bolt before affixing it through the lug (See instructions).
4. Do not exceed the recommended torque or under tighten these bolts, as both conditions can lead to potential failure mode of the system.

Impact:

The different battery terminals (compared to kit instructions) may result in uncertainty of technicians installing the auxiliary batteries, and possible improper assembly of the lugs to the battery.

Resolution:

Please review the instruction addendum and take appropriate steps to make sure we continue a high-quality installation when attaching these batteries.

INSTRUCTION ADDENDUM:

1. The Full River battery comes with brass automotive posts and M8 bolts and hardware bagged in the battery's box. When shipped there are no fasteners installed on the battery.



INSTRUCTION ADDENDUM (continued):

2. Instead of fastening the cable lugs onto the threaded marine terminals of the Discover batteries (like on the left), the technician will fasten the cable lug to the battery by putting the bolt and washers through the lug and then fastening onto the battery.



3. There is a specific order in applying the washers onto the bolt before affixing it through the lug.

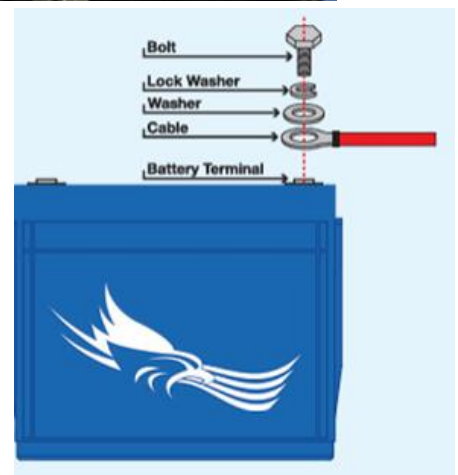

4. Do not exceed the recommended torque or under tighten these bolts, as both conditions can lead to potential failure mode of the system.

**Torque the M8 bolts to 7Nm
on the Full River Battery.**



Section 11A: Routing from CB to 2 AUX Batteries (KIT 66007 and 60331):

Step 11A-1. Routing AUX Fuse to AUX 1 Battery

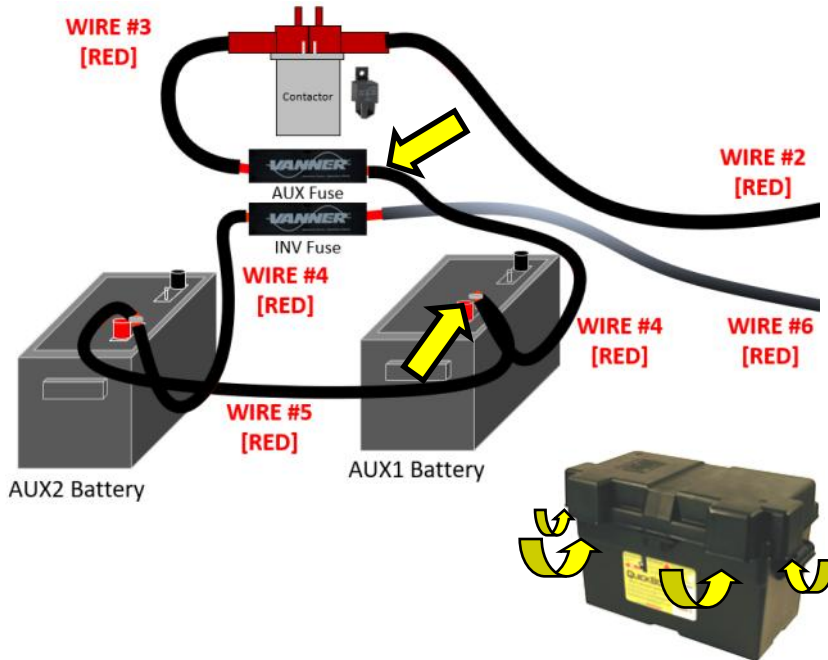

Section 11A Key: If two “WIRE” numbers: Use WIRE “#y” for KIT 66007 and “[y]” for KIT 60331. If one “WIRE” number, both use same wire number.

- **FROM Step 9A-21:** The **WIRE #4** is then routed to the positive terminal on the AUX 1 Battery. [Yellow Arrow to Yellow Arrow].
- **WIRE #5** is used to connect between AUX 1 and AUX 2 Positive terminals.
- Put the **WIRE #5** lug on the AUX 1 terminal (on the same terminal as the previous **WIRE #4**) and finger tighten the battery terminal nut (Ref. NO.:25). The nut will be holding down both lugs .
- The cable routing is important to ensure the battery box covers can be put on correctly. There are areas in the cover that allow the wires to pass down and out beneath the cover. See diagram to the left.

66007

Step 11A-2. Routing AUX 1 to AUX 2 Battery

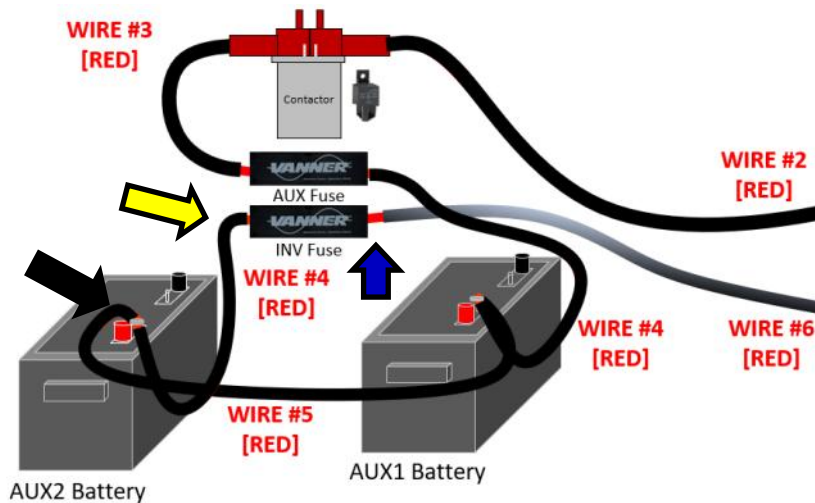

NOTE: at this point there are no fuses or grounds to complete this circuit, but always be aware of the position of each wire when installing

60331

- On the AUX 2 Positive Battery **terminal** (Black Arrow), put on the second lug of **WIRE #5** and second lug of the **WIRE #4** going to the INV Fuse (Yellow Arrow).
- The other lug of the second **WIRE #4** will be fastened to the inverter (INV) Fuse- finger tight the fastener (Ref. NO.:25) for the moment.
- Take one end of **WIRE #6** and fasten it to the other side of the INV Fuse- finger tight [see blue arrow].
- **WIRE #6** will be routed to the Inverter Positive Terminal in a future step.

Section 11A: Routing from CB to 2 AUX Batteries (KIT 66007 and 60331):

Step 11A-3. Routing AUX Fuse to AUX 1 Battery

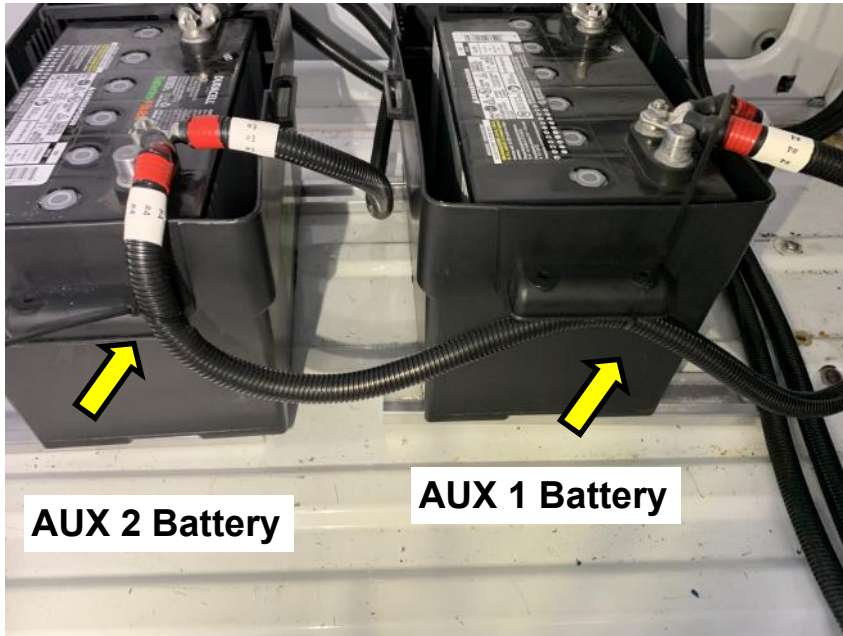

- You can see in the photo to the left that the **WIRE #5** has been cable tied to the handles of the battery boxes [See Yellow Arrows]. This prevents the loop from lying on the floor possibly as a trip hazard.
- The handles have holes to accommodate this.
- Notice, also that the battery carry handles are removed from the batteries in order to avoid interference when routing the wires.

66007

Step 11A-4. Routing the Wires to minimize battery footprint

60331

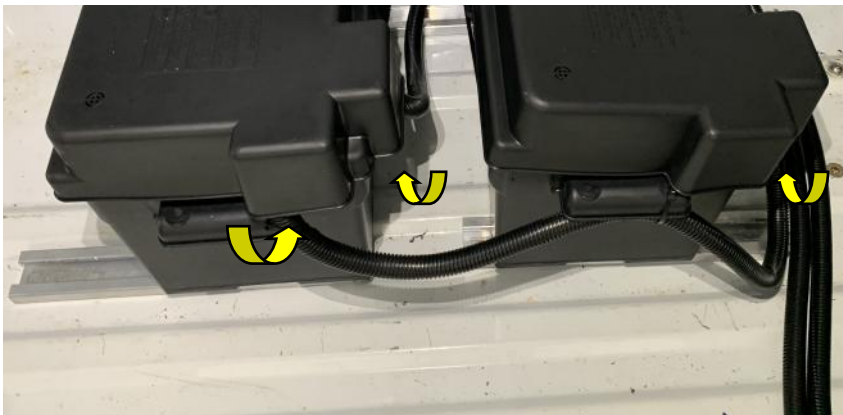

- For a look forward, you can see how the routing of the cables is important as to utilize the room given on the battery box lid. Do not torque down the cables on the terminals until the lugs are aligned so that the cables easily route out of the battery box utilizing the gaps on the cover.

Section 11A: Routing from CB to 2 AUX Batteries (KIT 66007 and 60331):

Step 11A-5. Negative Cable connections

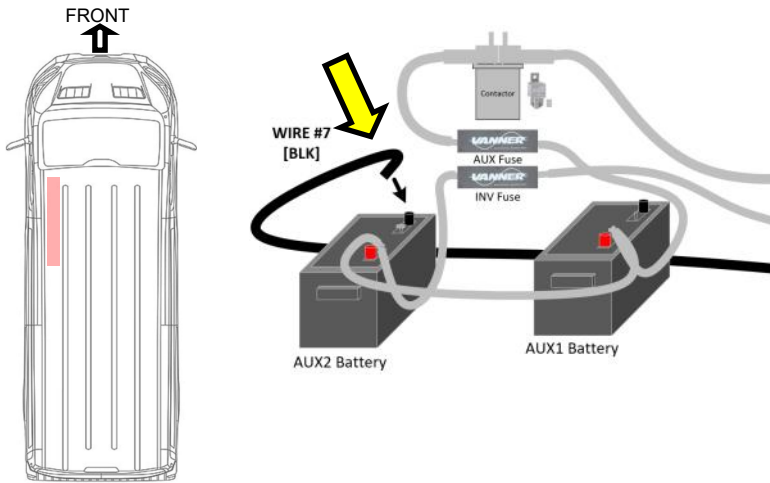

- Previously, **WIRE #7**, which is the ground wire from the chassis battery, has not been used and sitting on the floor of the cargo area.
- Bring this wire behind the AUX 1 & 2 batteries along the cargo area wall and connect to the AUX 2 *Negative* battery terminal.

Step 11A-6. Ground Cable Routing



Caution: Be aware that the other end of WIRE #8 should avoid accidental connections to any Positive terminals.

66007

- In this photo it can be seen that **WIRE #7** is brought around the negative post of AUX 2 Battery to be installed on the negative *Terminal*.
- The next **WIRE #8** that connects the AUX 2 to AUX 1 negative battery terminals is also put on same terminal.
- Finger tighten the battery terminal nut (Ref. NO.:25). The nut will be holding down both lugs.

60331

Step 11A-7. Remote Wire Routing

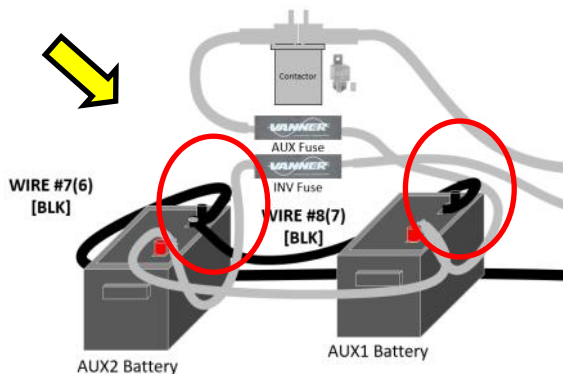

- Be aware of how the wires are routed so that they can easily come from beneath the cover.



Section 11A: Routing from CB to 2 AUX Batteries (KIT 66007 and 60331):

Step 11A-8. Ground Ring Terminal with Self-tapping Screw

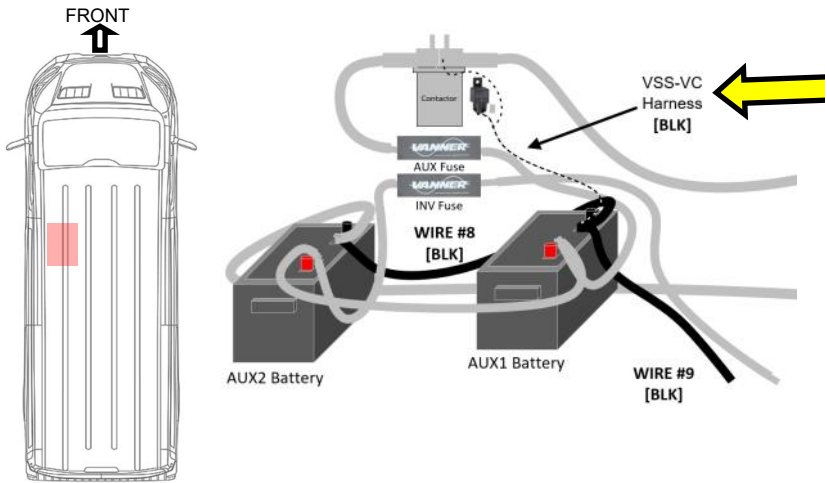

- Bring **WIRE #8** from the AUX 2 battery and attach to the negative terminal of AUX 1 Battery– hold it there.
- At the *same* time, bring **WIRE #9** that will be attached to the negative terminal of the inverter and stack one of it's lugs on top of the **WIRE#8** lug.
- At this point, bring the back ring terminal from the VSS-VC Harness and also stack it onto AUX 1 Battery negative terminal (See Yellow Arrow).

Step 11A-9. Remote Wire Routing

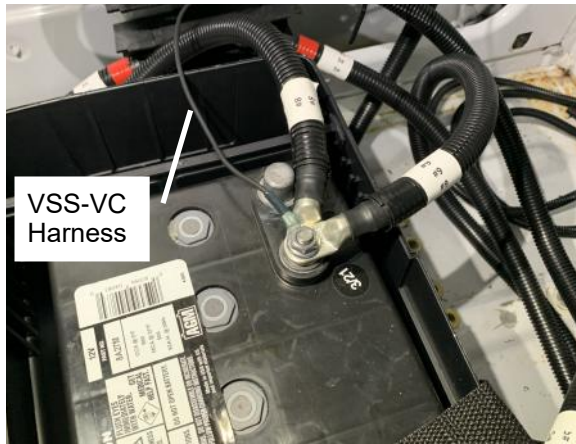

66007

- At this point all three wires will be on AUX 1 Battery negative terminal. Finger tighten the battery terminal fastener nut (Ref. NO.:25). to hold the wires in place.

60331

Step 11A-10. Remote Wire Routing



- At this point, the cables should roughly be all in place ready for tightening.

Section 11A: Routing from CB to 2 AUX Batteries (KIT 66007 and 60331):

Step 11A-11. Hold the cables while tightening

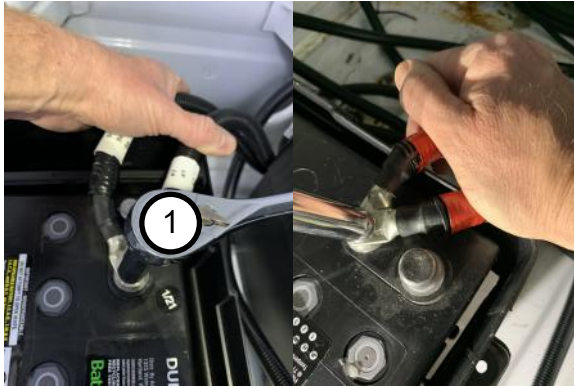
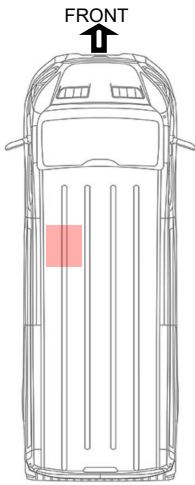

- As the terminals are tightened, hold them into alignment for the openings in the tops of the battery boxes.

- 1 The Auxiliary battery terminal fastener nuts (Ref. NO.:25). will be torqued down to 8Nm [+/- 1.2Nm] (71 lb.in) with a 1/2" socket.

Step 11A-12. Position and Routing of Battery Box Straps



66007

- Ensure the battery straps are positioned under the battery boxes (here they are routed underneath and the ends are overlapped onto the top of the batteries temporarily).

60331

Step 11A-13. Install the Battery Box Lids



- While installing the tops, guide the cables into the openings on the edges of the lids.
- The tops of the boxes are to be snapped on and the battery straps should be tightened around each box.

Section 11A: Routing from CB to 2 AUX Batteries (KIT 66007 and 60331):

Step 11A-14. System ready for connection of Inverter

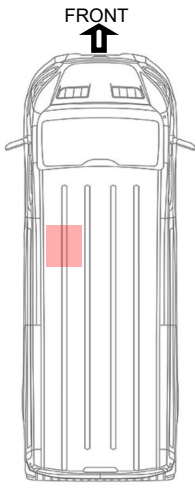

- The boxes should be secure and there should be just two battery cables coming from the auxiliary batteries (**[RED] WIRE #6 & [BLK] WIRE #9**).
- There should be the remaining Orange remote control wire (**WIRE #13 [11]**) and a remaining Green chassis ground (**WIRE #10**).

66007

60331

Section 11B: Routing from CB to 1 AUX Battery (KITS #66221 & *62046):

Step 11B-1. Routing AUX Fuse to AUX 1 Battery then to INV

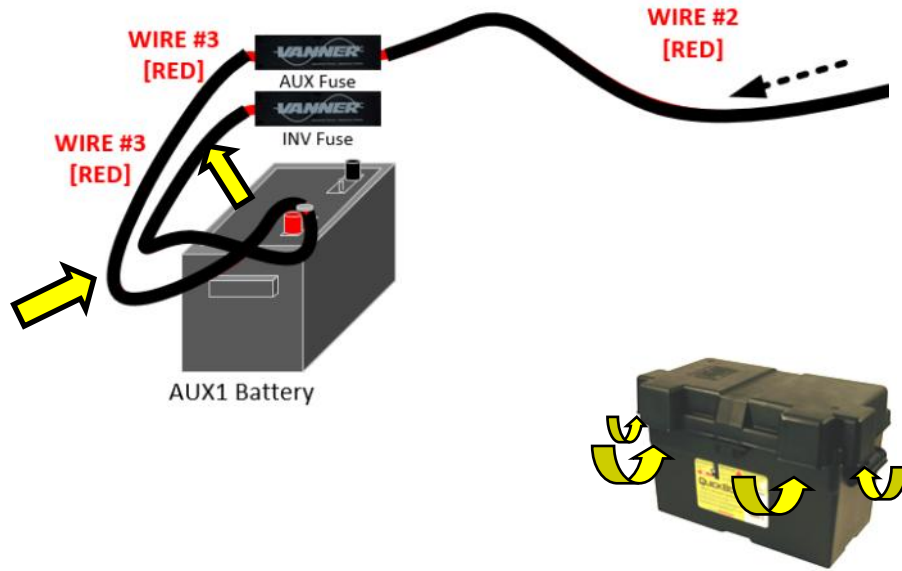

- FROM Step 9B-7: The **WIRE #3** is then routed from AUX Fuse to the positive terminal on the AUX 1 Battery. [Yellow Arrow to Yellow Arrow].
- On the AUX 1 Positive Battery **terminal** (White Arrow), put on the second lug of the second **WIRE #3**.
- **The other end of WIRE #3** will go back to the INV Fuse (Yellow Arrow). Install the INV Fuse terminal fastener finger tight at this time.
- The cable routing is important to ensure the battery box covers can be put on correctly. There are areas in the cover that allow the wires to pass down and out beneath the cover. See diagram to the left.

Step 11B-2. Routing AUX 1 to AUX 2 Battery

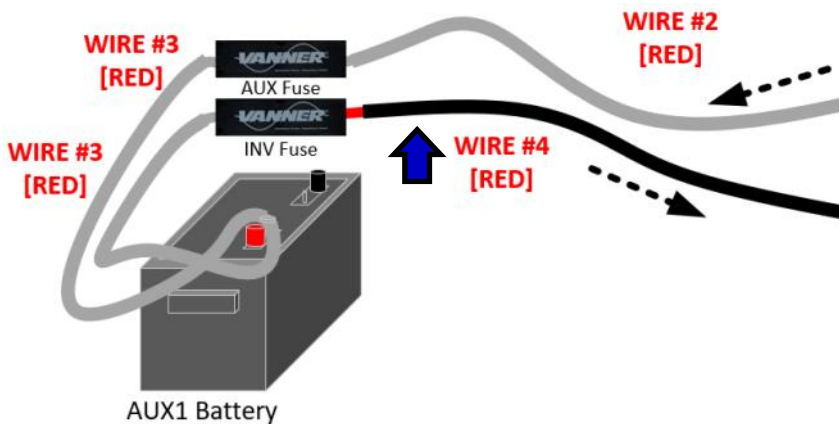

NOTE: at this point there are no fuses or grounds to complete this circuit, but always be aware of the position of each wire when installing

- Take one end of WIRE #4 and fasten it to the other side of the INV Fuse— finger tight [See Blue Arrow].
- **WIRE #4** will be routed to the Inverter Positive Terminal in a future step.

Section 11B: Routing from CB to 1 AUX Battery (KITS #66221 & *62046):

Step 11B-5. Negative Cable connections

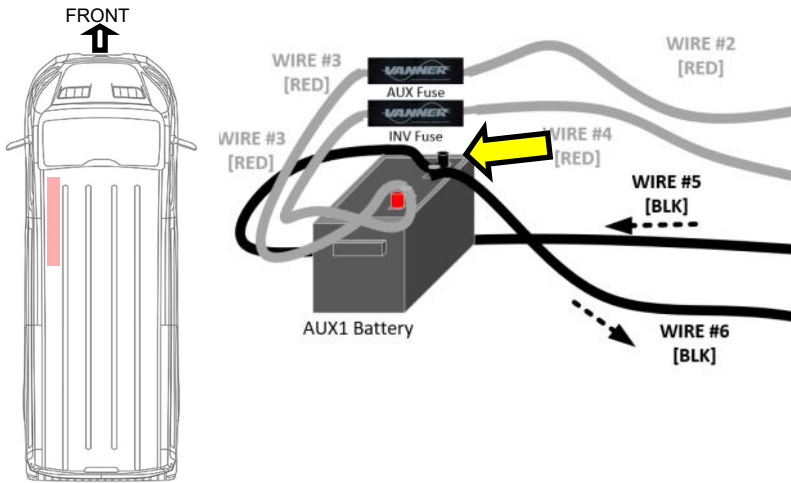

Caution: Be aware that the other end of **WIRE #6** should avoid accidental connections to any *Positive* terminals.

- Previously, **WIRE #5**, which is the ground wire from the chassis battery(ies), has not been used and sitting on the floor of the cargo area.
- Bring this wire behind the AUX 1 battery along the cargo area wall and connect to the AUX 1 *Negative* battery terminal. (See Yellow Arrow).
- At the same time **WIRE #6** is connected to that terminal and will be routed back to the inverter. Finger tighten the battery terminal nut. The nut will be holding down both lugs.

Step 11B-6. Ground Cable Routing



- Be aware of how the wires are routed so that they can easily come from beneath the cover.

Step 11B-7. Remote Wire Routing

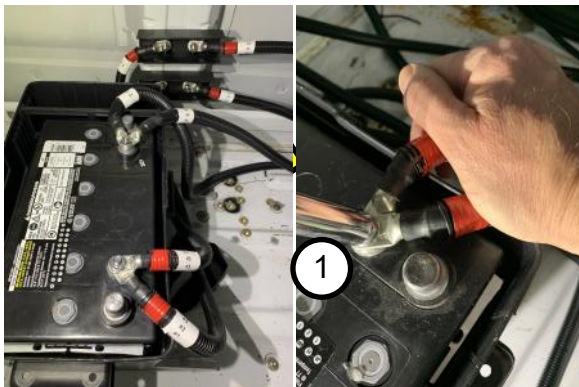

- At this point, the cables should roughly be all in place ready for tightening.
 - Hold them into alignment for the openings in the tops of the battery boxes.
- ① The Auxiliary battery terminal fastener nuts (Ref. NO.:25). will be torqued down to 8Nm [+/- 1.2Nm] (71 lb.in) with a 1/2" socket.

Section 11B: Routing from CB to 1 AUX Battery (KITS #66221 & *62046):

Step 11B-8. Battery Box Closed and Strapped

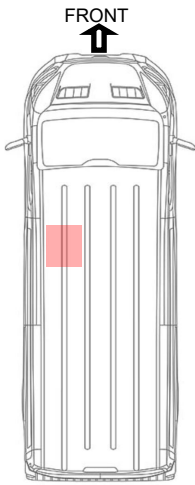

- Ensure the battery straps is positioned under the battery box.
- While installing the top, guide the cables into the openings on the edges of the lid.
- The top of the boxes isto be snapped on and the battery strap should be tightened around each box

Step 11B-9. System ready for connection of Inverter



- The box should be secure and there should be just two battery cables coming from the auxiliary battery area: WIRE #4 [RED] and WIRE #5 [BLK].
- There should be the remaining Orange remote control wire and a remaining green chassis ground wire to finish electrically connecting the system at this point [aside for any accessories like power strips, which is not included in this instruction].

Section 12: Inverter Installation-Wiring and Cabling:

Step 12-1. 1.5 & 2kW Inverter Preparation



- Before mounting inverter to the partition, there will likely be limited space to connect the wiring. It is advised that the connections are made before installation, depending on the access.
- Loosen the 1/2" nut and washers on terminals and remove them for a moment.

Step 12-2. Terminal Covers



- The terminal covers are important to include when installing the wires to the Inverter.
- The screws will hold them over the terminals.

Step 12-3. 1500W Inverter Cable Setup



- Put the terminal covers on the cables in the proper direction before installing.
- Loosen the 1/2" nut washers on terminals and remove.

Section 12: Inverter Installation-Wiring and Cabling:

Step 12-4. Orientation of Cables into Inverter

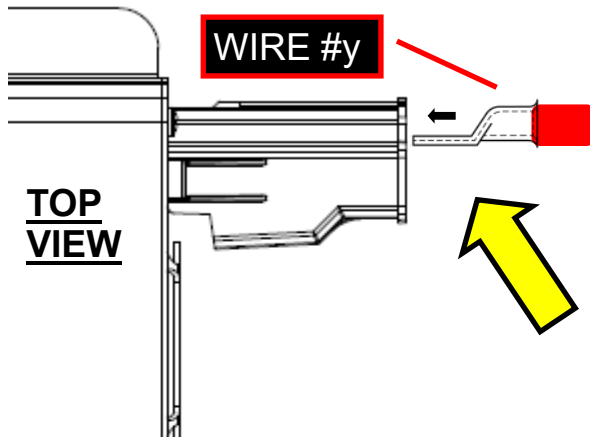

The lugs should fit squarely into the terminal covers and sit flat upon the terminal surface. They may need to be turned over.

- Bring the cables from the AUX Battery (ies) neatly to the terminals on the inverter.
- Be sure to orient [see Yellow Arrow] the cable lug so that it fits squarely into the inverter terminal (flat side towards the terminal).

← **TOP VIEW**

Step 12-5. Fastening Cables to Terminals

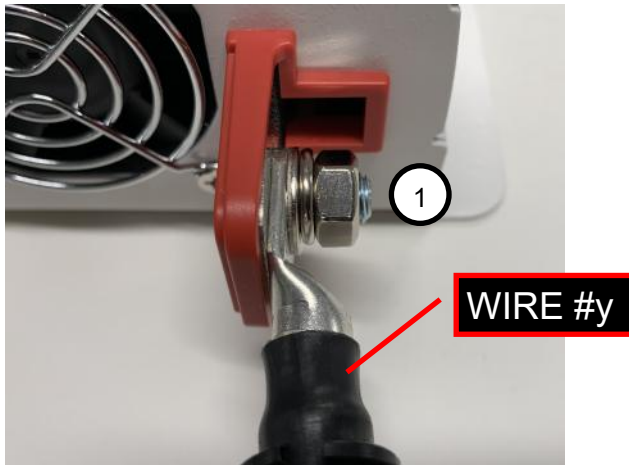

Caution: All DC connections should be tightened to proper torque to avoid loosening during time in service.

- 1 These Positive and Negative connections shall be torqued to 12.4Nm [+/- 0.7Nm] (110 lb.in.).

Step 12-6. Installation of Covers over Terminals



- Bring the terminal covers over the torqued cable lugs and use screws to snugly fastener them (they will only fit in one orientation).

Section 12: Inverter Installation-Wiring and Cabling:

Step 12-7. Inverter Chassis Ground Installation



Caution: All DC connections should be tightened to proper torque to avoid loosening during time in service.

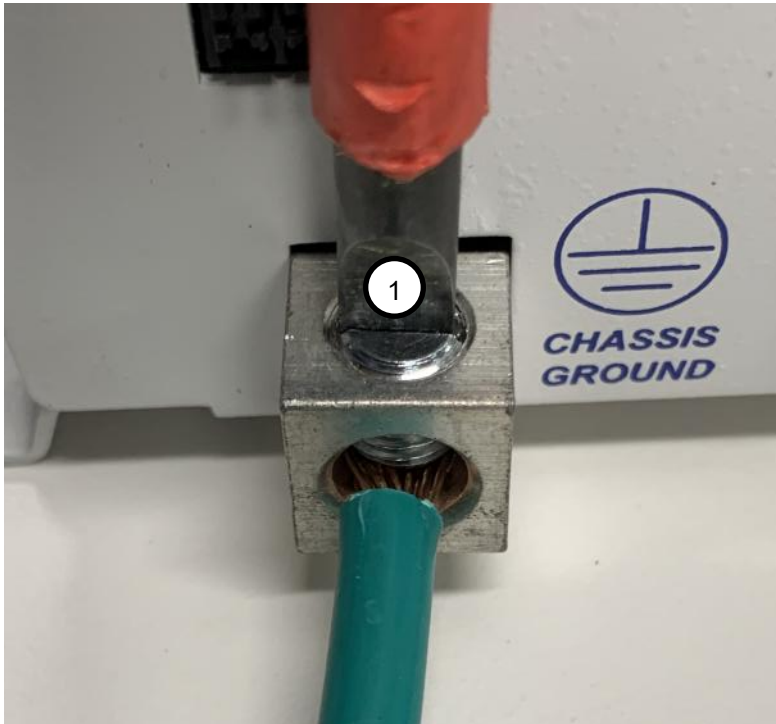

- The 8AWG **GREEN** Inverter ground **WIRE #10 (or 6 or 7)** [depending on cable kit] has an end with the insulation pre-cut

- Remove the insulation and clamp into the Chassis Ground terminal.

1

This connection shall be torqued to 12.4Nm [+/- 0.7Nm] (110 lb.in).

Step 12-8. Remote Wire Connection to Inverter

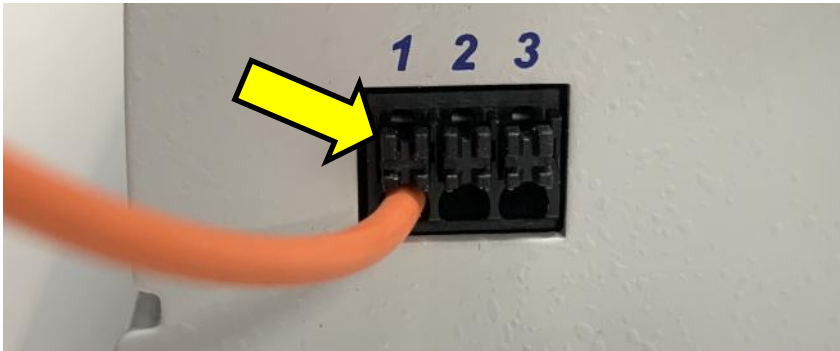

- The remote **Orange WIRE #13 (or 10 or 8 or 11)** installed earlier is length adjusted so there is not excessive extra length. It can also be coiled and fastened with wire tie.
- The Orange **WIRE 13 (or 10 or 8 or 11)** is stripped about 3/8", twisted to avoid strays, and pushed into the #1 terminal in the black remote control header.
- If it must be released for any reason, push the square button above the terminal hole *and hold* to disengage the spring clamp, then pull the wire out.

Section 12: Inverter Installation-Wiring and Cabling:

Step 12-9. Inverter Front Face



- This side of the inverter will face the center of the vehicle.
- On the front side of the inverter, insure the setting switches are correct...

Step 12-10. Function Switches

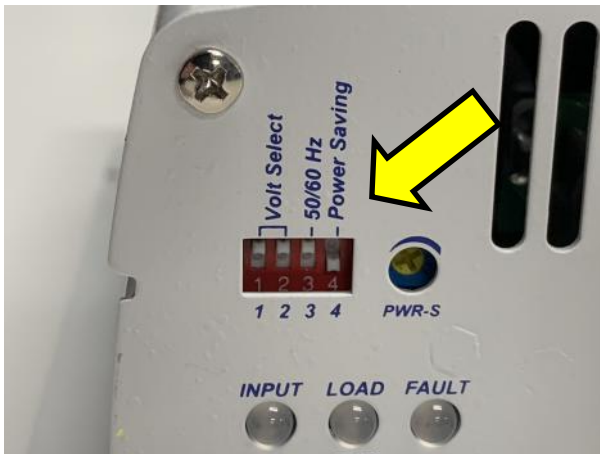

- The inverter function switches should be set to:
- 1-UP/2-UP/3-UP/4-Down [120V, 60Hz, with power saving OFF].

Step 12-11. Remote Switch Confirmation

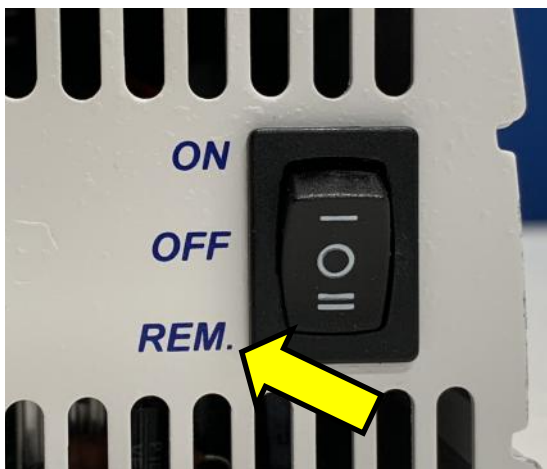

- The Inverter switch must be switched to "REM." (remote) to avoid inadvertent discharge of the battery(ies).

Section 12: Inverter Installation-Partition/Bracket:

Step 12-12. Inverter Installation to Partition

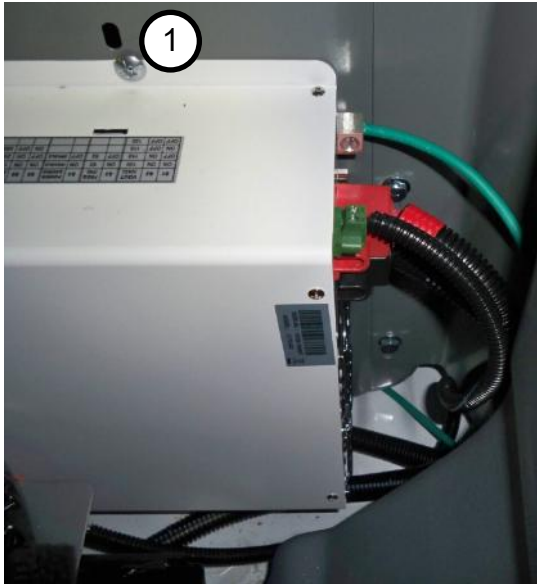
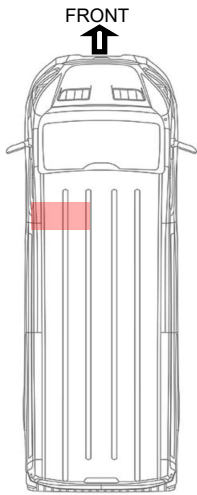

- Install the inverter horizontally in the pre-drilled holes in the partition (There may be several hole positions for different sized inverters) OR mount to the appropriate holes in the Composite Partition Accessory Mounting Kit (sold separately).
- Use FAS0055 (Ref. NO.: 2) and FAS0018 (Ref. NO.: 3) to mount the inverter to the partition itself or rails provided on the partition.

① The recommended tightening torque for these fasteners is 12Nm [+/- 1.8Nm] (106lb.in) with a 7/16" socket.



Step 12-13. Inverter Ground Wire



- The other end green inverter ground **WIRE #10 (or 6 or 7)** will have a ring terminal that must be fastened to a local chassis ground.
- The partition hold down fastener near the inverter holding the partition to the floor is recommended.
- Utilize torque specification found for that fastener in the partition installation kit.

Section 13: Fuse Installation

Step 13-1. Fuse Size Reference

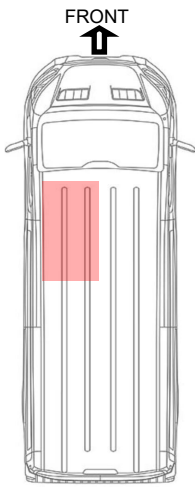

- For Reference, the fuses sized to each kit are here.
- Do not use a fuse exceeding the rating of the system.
- KIT 66007: 250,250,400A
- KIT 66221: 250,250,200A
- KIT 62046: 250,250,200A
- KIT 60031: 250,250,400A

Step 13-2. Insert MEGA Fuse into CB Fuse Holder



Caution: The WIRE #1(1) is a live wire. It needs to be controlled while adding fuse.

- Make Sure Red Rocker Switch is in off position.
- Carefully unscrew and remove the nuts/washers from the fuse terminals while holding the **WIRE #1** and **WIRE #2** down on the posts.
- Place the **250A** fuse across the terminals and fasten the nut on **WIRE #1 first**.
- Fasten the other nut onto the **WIRE #2** terminal.

Step 13-3. Close Fuse Holder

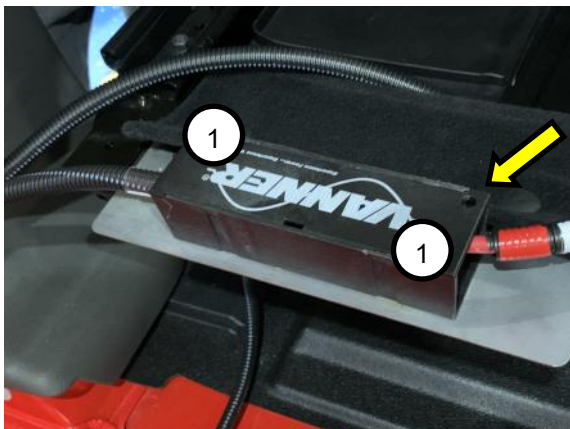

Caution: During torquing be aware of touching other grounded metal parts!

- 1 Both fuse fasteners should be torqued to 12Nm (106lb-in) with 1/2" socket.
- Replace the safety cover onto the fuse holder and assure that it snaps in place.
- Use a cable tie to secure the safety cover. There are holes in the corner of the cover and plastic body of the holder (see Yellow Arrow) to feed through a tie and cinch.

Section 13: Fuse Installation:

Step 13-4. Insert MEGA Fuse into AUX Fuse Holder

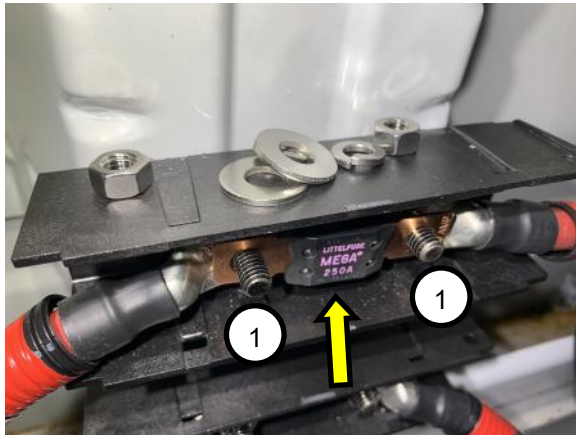
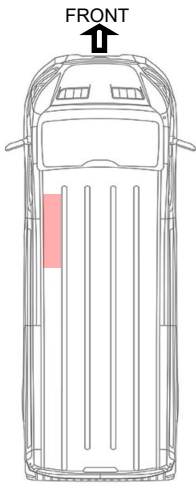

Caution: The AUX Fuse WIRE #2 & WIRE #3 are live wires. They need to be controlled while adding fuse.



Caution: During torquing be aware of touching other grounded metal parts!

- Remove fasteners and washers from the AUX Battery fuse holder.
- Please hold wires to ensure they stay on the terminals until fuse is installed.
- Insert the second **250A** Fuse over the terminals in the fuse holder and re-fasten washers and nuts.

- ① Both fuse fasteners should be torqued to 12Nm (106lb-in) with 1/2" socket.

Step 13-5. Insert MEGA Fuse into INV Fuse Holder

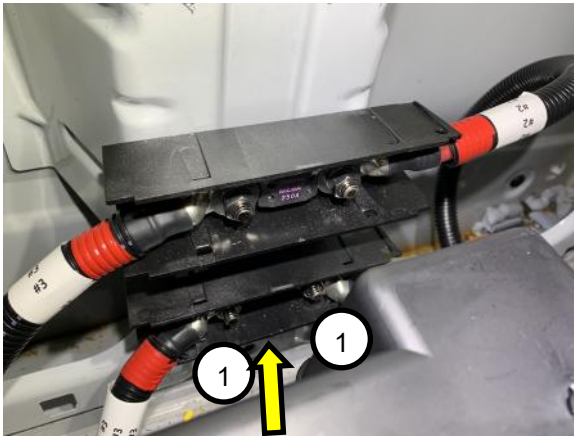

Caution: The INV Fuse WIRE #3 is a live wire. It needs to be controlled while adding fuse.



Caution: During torquing be aware of touching other grounded metal parts!

- Remove fasteners and washers from the INV Battery fuse holder [Yellow Arrow].
- Insert the **400A (or 200A)** Fuse over the terminals in the fuse holder and re-fasten washers and nuts.

- ① Both fuse fasteners should be torqued to 12Nm (106lb-in) with 1/2" socket.

Step 13-6. Close Fuse Holder



- Replace the safety cover onto the fuse holder and assure that it snaps in place.
- Use a cable tie to secure the safety cover. There are holes in the corner of the cover and plastic body of the holder (see Yellow Arrow) to feed through a cable tie and cinch.

Section 14: Important Labeling

Step 14-1. Apply Remote Inverter Switch Label (Kits 66007 & 66221)

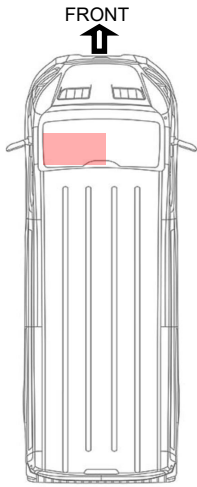

- Install the circular “INVERTER 120V AC” label at the red remote switch on the knee bolster panel.

Step 14-2. Apply Remote Inverter Switch Label (67C Kit 60031 and 62046)



- Install the rectangular “INVERTER 120V AC” label at the upfitter Switch: AUX 1 in the center front seat console.

Step 14-3. Apply Remote Inverter Switch Label

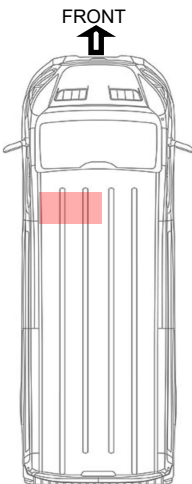

- Install the Blue Notice Label on the side of the inverter that is facing up after installation.

NOTICE
The power switch on this unit MUST be left in the REM (REMOTE) position to ensure correct operation of the inverter system. Changing the position of the switch can deplete the OEM batteries and require a jumpstart.

Section 14: Labeling:

Step 14-4. Apply Auxiliary Battery Caution Label

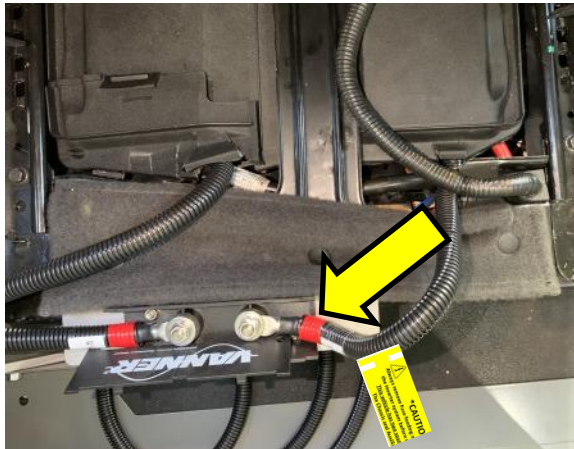
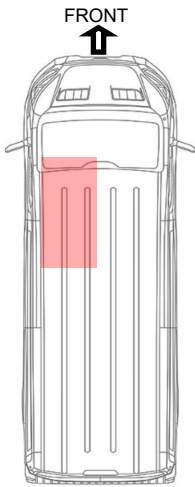

- Install the Yellow tag with Zip Tie to battery cables at OEM Battery and AUX 1 Battery.

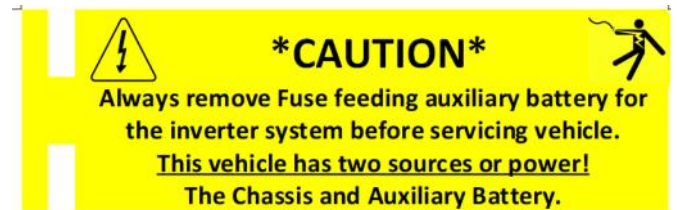

Section 15: Test and Check

Step 15-1. Test the inverter function

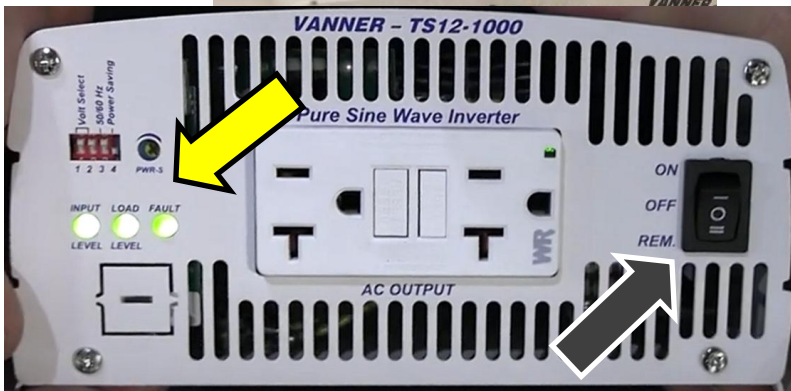

Warning: Make sure all AC connections are made appropriately before power up.

Test: Verify Inverter Powers Up

- Ensure the INVERTER power switch is set to "REMOTE" [Grey Arrow]
- Start the engine or turn ignition to "ON" position.
- Turn on the RED remote inverter switch in the dash.

What to expect:

- Verify all three round green LEDs light up green with nothing plugged in [See Yellow Arrow].
- If any of the LEDs are not Green, turn off the system and check all wiring.

Step 15-2. Check GFCI operation

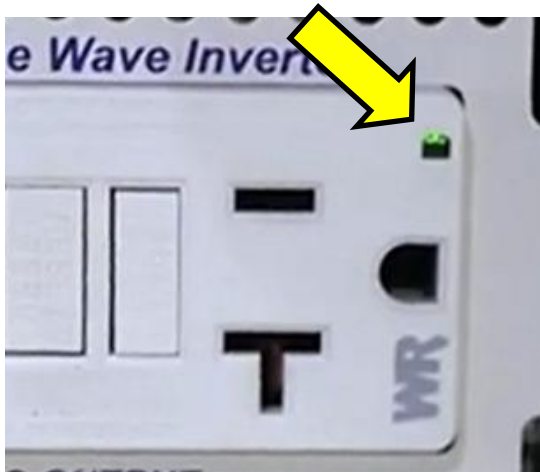

Test: Verify GFCI Light is Green.

- While the inverter is powered, confirm the GFCI green light is on. Again- nothing should be plugged in.

What to expect:

- If the light is Green, go to the next step
- If the light is red, push the GFCI RESET button. This should reset the device to green.

Step 15-3. Test the inverter power output



Test: Insert Inverter Output.

- **Plug in** any accessories such as power strips included with the kit.
- Utilize an extension cord with the Voltage meter/ GFCI Tester into one of the outlets on the inverter.
- GFCI outlet Tester will indicate any faults.

What to expect:

- The power output should be at correct voltage and polarity. A reading of 114Vac – 122Vac is expected.
- GFCI should indicate "Correct" or OK.
- If voltage is not in that range please STOP and notify Team Lead.

Section 15: Finish & Test:

Step 15-4. Routing and Clipping



- Turn off dash switch for transportation and leave the black inverter mounted switch in “REM”.
- Using the supplied wire ties make sure all wiring is secured and clear of sharp objects, moving parts, and heat sources.
- Ensure all trim removed in previous steps is secure and neat.

**INSTALLATION INSTRUCTIONS
HAVE FINISHED**

Section 16-A: Fleet Appendix-Wiring Diagrams

Two AUX Batteries + Contactor (KIT 66007)

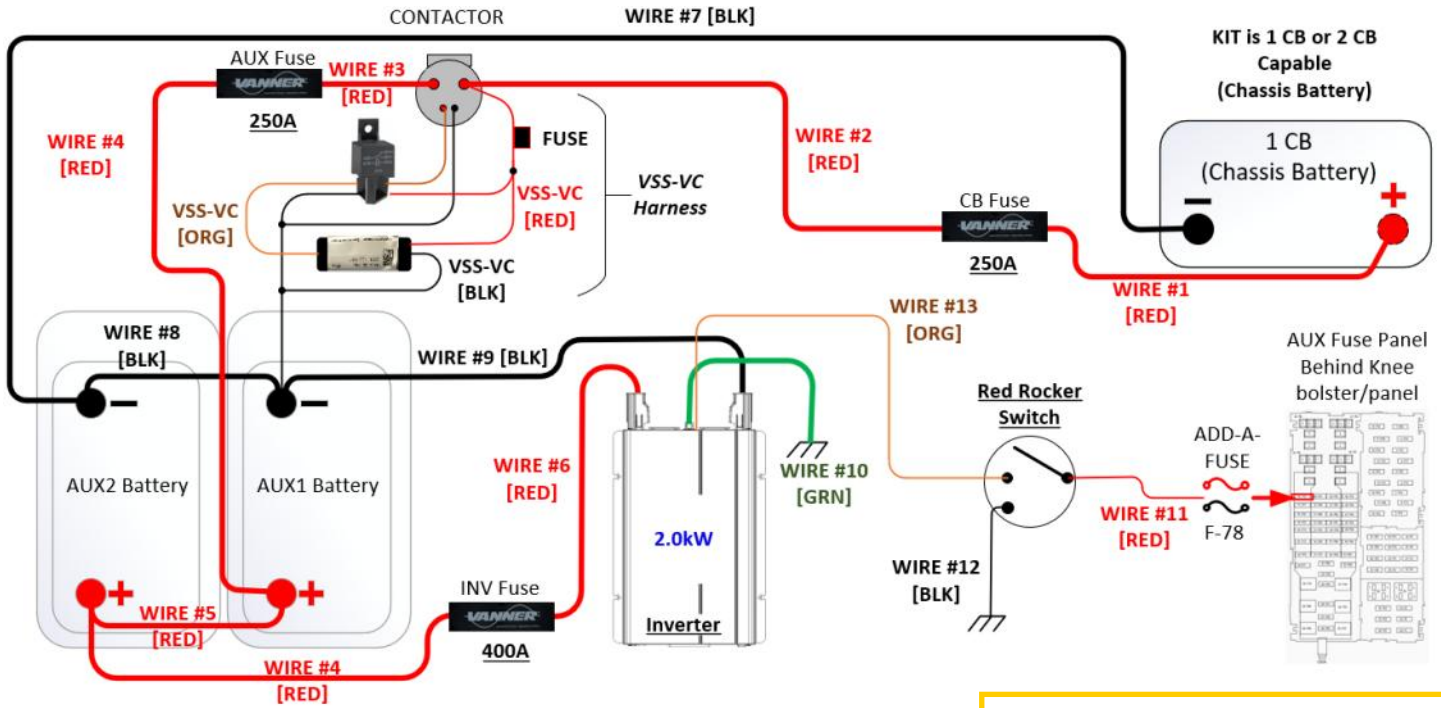

Figure 5-1: Complete Wiring Diagram for kit with a Contactor

NOTE: New Fuse Box shape (on Pg.20) and fuse locations for MDY2026 and beyond.

One AUX Battery + Timer (Kit #66221) :

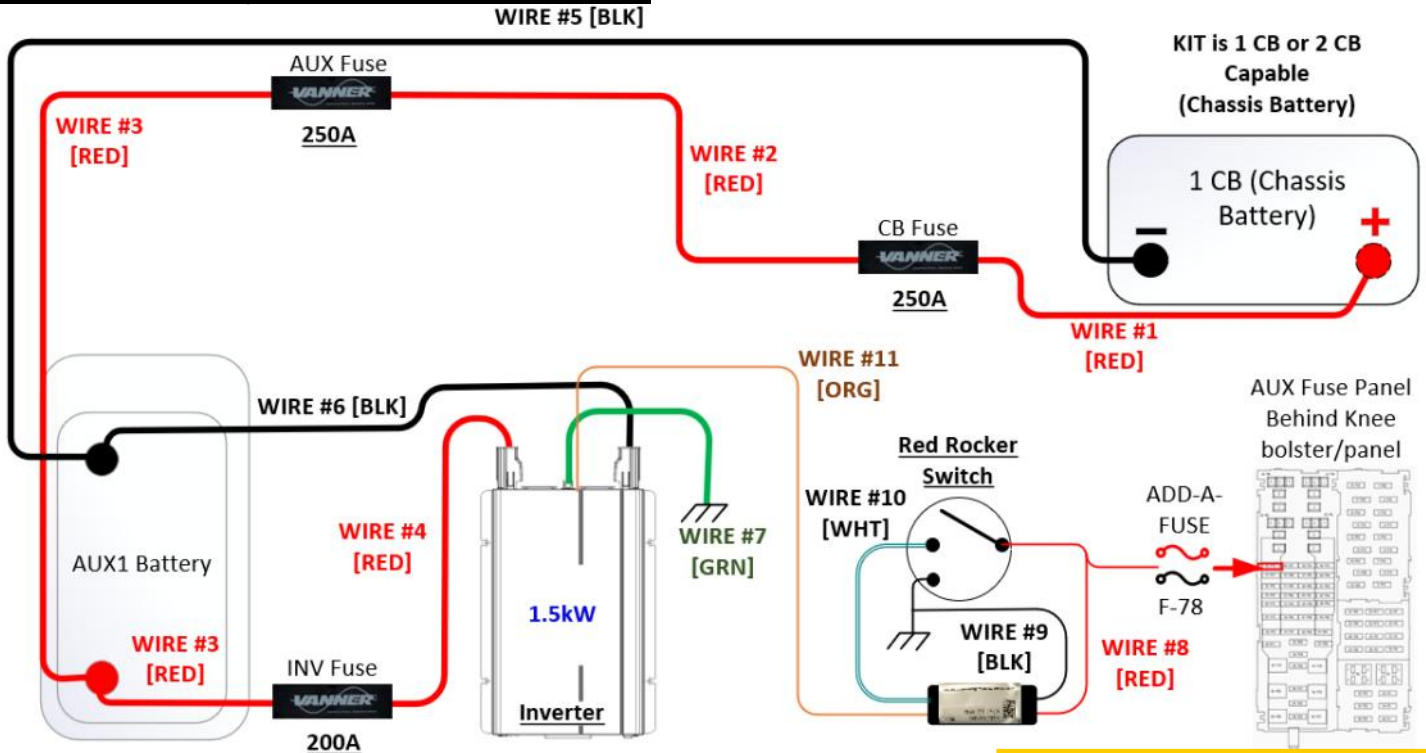

Figure 5-2: Complete Wiring Diagram for kit with a timer switch

NOTE: New Fuse Box shape (on Pg.20) and fuse locations for MDY2026 and beyond.

Section 5: General Wiring Diagrams:

One AUX Battery + 67C Option (Kit *62046)

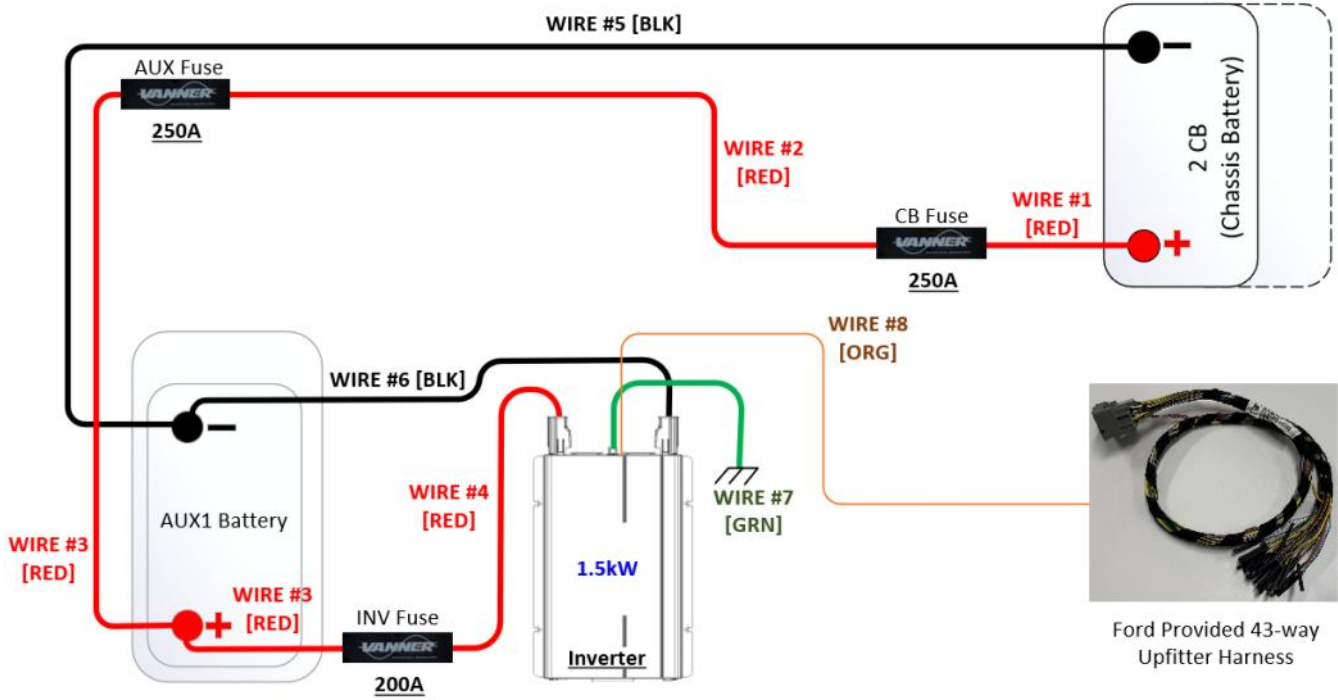
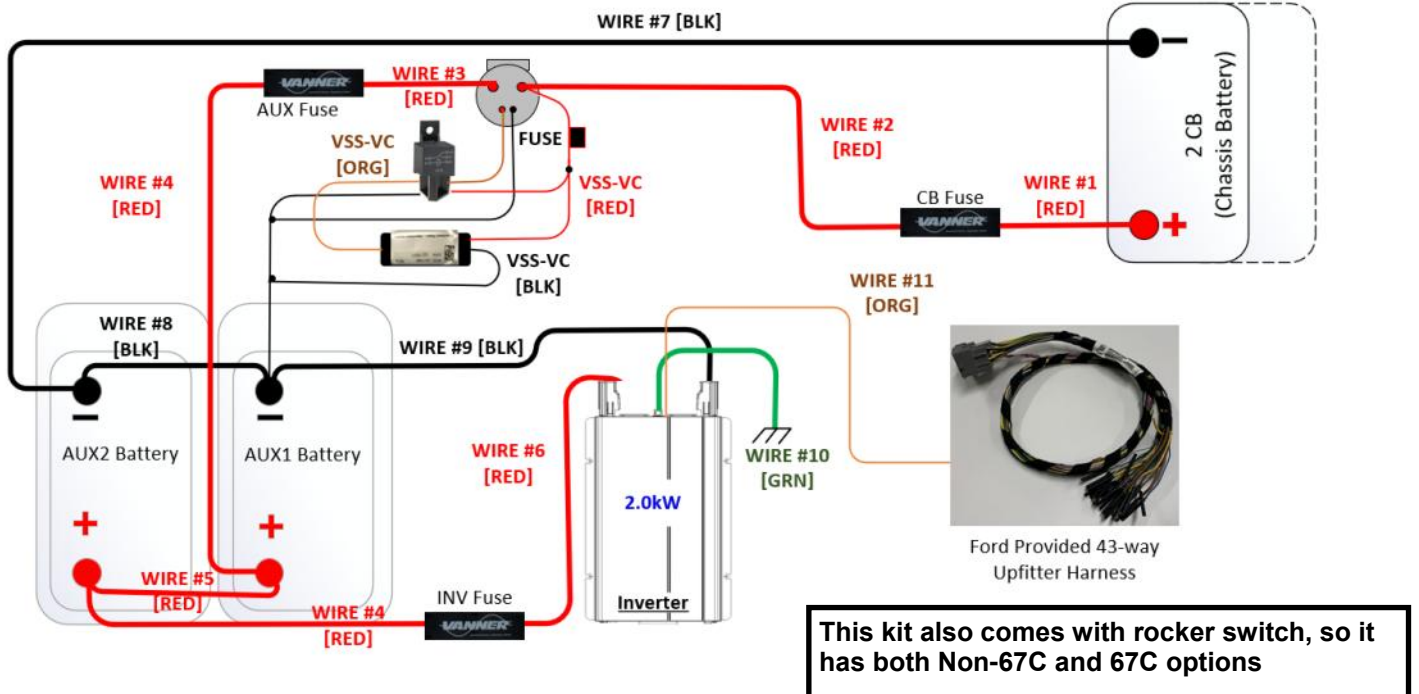

Figure 5-3: Complete Wiring Diagram for 67C Option Included



This kit also comes with rocker switch, so it has both Non-67C and 67C options

Section 16-A: Fleet Appendix– Tools Needed



1. Insulated Splice Crimper
2. Wire Strippers
3. Diagonal Cutters
4. Plastic Trim Tool
5. Drill driver
6. Measuring tape
7. Phillips Bit with Bit holder
8. 3/4" Hole or Step Drill (Unibit)
9. Medium and Small (-) Screwdriver
10. Large #3 Phillips (+) Screwdriver
11. Sockets:
 - 8mm, 10mm, 13mm
 - 5/16", 3/8", 7/16", 1/2"
 - Socket driver and extensions
12. Torque Wrench [~8-20Nm range]
13. Tin Snips
14. #3 Philips (+) & Medium slotted torque socket
15. Marker [Not Shown]
16. Plusnut gun
17. 3/8", 1/2" drill, 1" hole saw (if applicable)

Figure 3-1: Tools Needed for Installation

Section 16-A: Fleet Appendix– Additional Notes

NOTES:

- Battery Negative is not disconnected for these procedures. For safety it is generally recommended, but Ford BBS suggests not unhooking unless the battery is being changed.
- Only insert large MEGA fusing when ready to check functionality of the system after is installed.
- Be sure the MEGA fuse is correct size according to Inverter Cabling Kit PPDS.
- Installing on a Composite Partition requires extra procedure of installing accessory brackets.
- When installing on cargo side of partition, be sure cables are fed through the holes with grommets installed.
- The Green 8AWG WIRE [#10 for KIT 66007 & #7 for KITS 66221 and 62046] may need to be installed on mounting fastener of the inverter or other location if the partition does not have grounded fasteners holding it to chassis.

DC Input Side Panel Wiring Diagram:

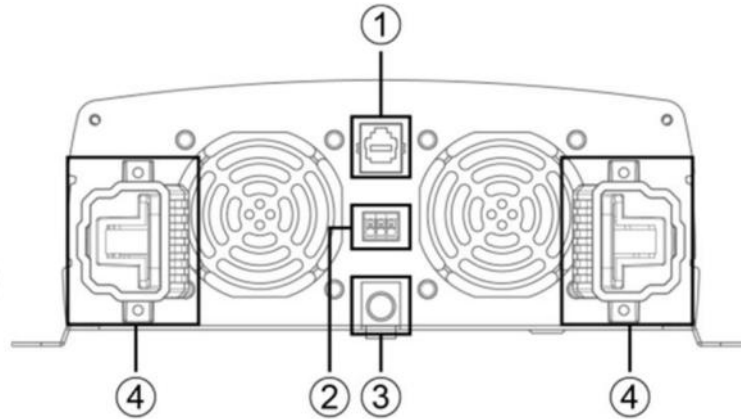

TS-1500W and TS-2000W

Model	TS Series
①	Factory Port
②	Remote control black terminal
③	Chassis ground
④	DC input connector

Section 16-A: Fleet Appendix- Kit Fasteners and Torque Table

Torque Table:

ITEM NO.	ASC PN	Description	PCS	Torque Range	Use Wrench or Size
1	BAG0406-A	4" x 6" 3MIL AUTOBAG	1	--	
2	FAS0055	Nut, Hex Flange, Nylock 1/4-20	4	12Nm [+/- 1.8Nm] (106lb.in).	7/16"
3	FAS0018	SCREW, HH SFLNG 1/4-20X.62 ZP	4	12Nm [+/- 1.8Nm] (106lb.in).	7/16"
4	FAS0048	Screw, Button Hd Hex Soc, 5/16-18X2, ZN	8	15Nm [+/- 1.8Nm] (132lb.in).	3/8" Allen
5	FAS0025	Screw, Truss Hd. Ph, #10-24x0.50	4	3Nm [+/- 0.5Nm] (27lb.in).	#2 Phillips
6	FAS0029	NUT, HEX NLK 10-24 ZP	4	3Nm [+/- 0.5Nm] (27lb.in).	3/8"
7	FAS0159	NUT, HEX TPLK M6X1.0	2	8Nm [+/- 1.2Nm] (71lb.in).	10mm
8	FAS0091	Plusnut, 5/16	8	--	--
9	FAS0833	WASHER, CUP FLANGED 1.5"	8	--	--
10	03927-1	SPACER, FLR, 1010, 11/32 ZP	8	--	--
11	FAS0148	Screw, Self Drill/Tap, Pan Ph. Hd., #10x0.5, NI-ZN	1	3Nm [+/- 0.5Nm] (27lb.in).	#2 Phillips
12	FAS0360	SCREW, ST, THP 14-10X.75 SS	4	3Nm [+/- 0.5Nm] (27lb.in).	#2 Phillips
13	FAS0629	Screw, Self Drill/Tap, Wafer Ph. Hd., #10x1.5NI-ZN	2	3Nm [+/- 0.5Nm] (27lb.in).	#2 Phillips
14	FAS0032	Screw, Flat Phillips Hd, #10-24x1.0	2	3Nm [+/- 0.5Nm] (27lb.in).	#2 Phillips
15	FAS0020	Nut, Hex Flange, #10-24	2	3Nm [+/- 0.5Nm] (27lb.in).	3/8"



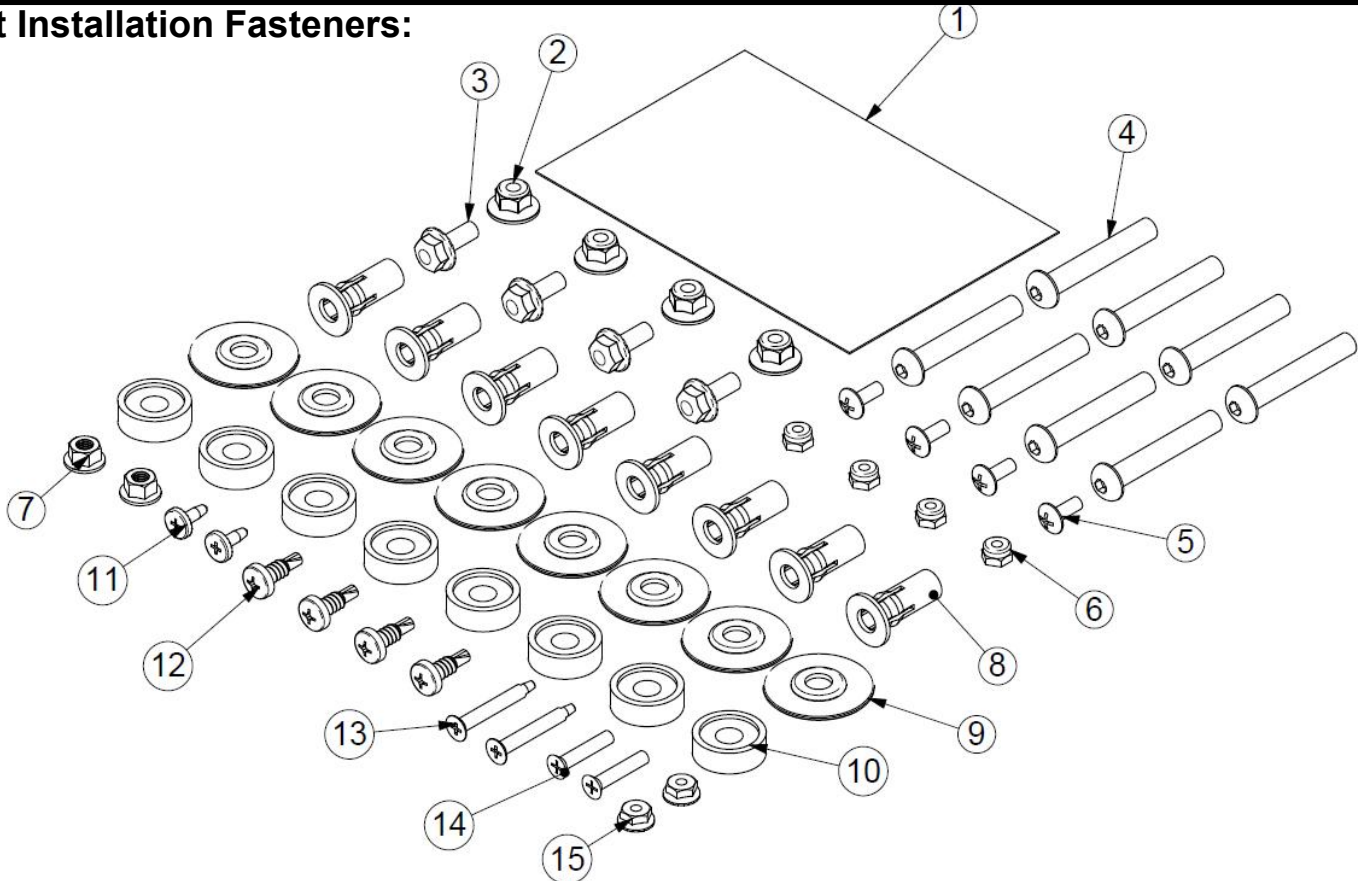

Please NOTE: Certain fasteners or hardware may not be used for certain kits or installations.

BAG66631

Kit Installation Fasteners:

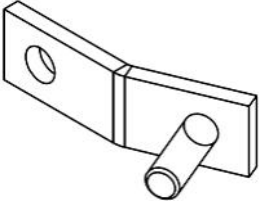

Section 16-A: Fleet Appendix- Kit Fasteners and Torque Table

Ref. NO.	ASC PN	Description	PCS	Torque Range	Use Wrench or Size
12		Positive Battery Terminal busbar 	1	8Nm [+/- 1.2Nm] (71 lb.in).	5/16"
13		Positive Battery Terminal busbar 	1	-Will USE FAS0159 will be 8Nm [+/- 1.2Nm] (71 lb.in).	—
14		Cables to VANNER Fuse Holder 	4	12Nm [+/- 1.8Nm] (106lb.in).	1/2"
15		Chassis Battery Fuse Holder to bracket nuts [KEPS] 	2	3Nm [+/- 0.5Nm] (27lb.in).	3/8"
16		Inverter +/- Terminals Phillips and slotted screws	Three (3) Positions	8Nm [+/- 1.2Nm] (71 b.in).	#3 Phillips and 1/4" Standard driver bits
17		Contactor Mains 	2	10.2Nm [+/- 1.1Nm] (~90 lb.in).	1/2"
18		Contactor coil 	2	2.5 Nm [+/- 0.9 Nm] (~22.5 lb.in).	3/8"
Other Fasteners in Vehicle					
19		CB Positive Battery Post Clamp —	1	8Nm [+/- 1.2Nm] (71 lb.in).	10mm NUT
20		CB Negative Battery Cable to Battery Clamp —	1	8Nm [+/- 1.2Nm] (71 lb.in).	13mm Nut
21		AUX positive and negative terminal fasteners —	2 or 4	8Nm [+/- 1.2Nm] (71 lb.in).	1/2" Nut
22		Fuse holder & Battery Hold Down Bracket —	2	10Nm [+/- 1.5Nm] (89 lb.in).	8mm or 10mm Screw

Please NOTE: Certain fasteners or hardware may not be used for certain kits or installations.

Section 16-B: Plusnut Appendix

Installation of Plusnut mounting hardware

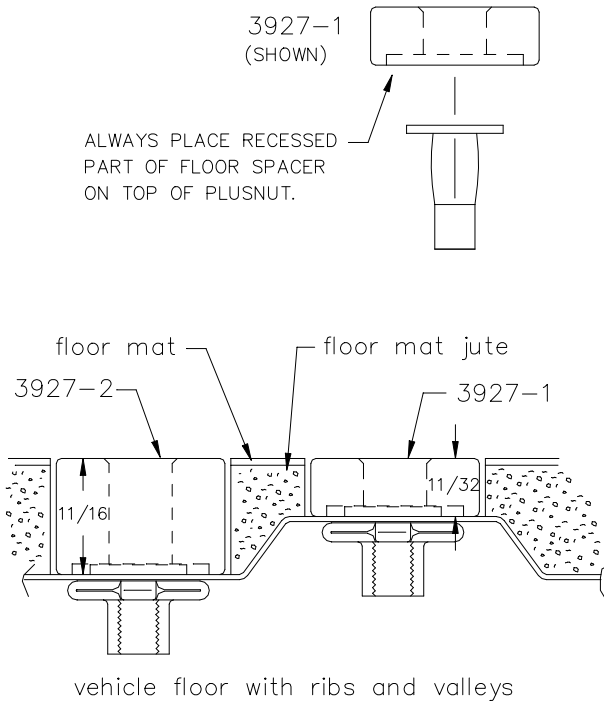

- If your vehicle contains carpet or a rubber floor mat you will need to prepare the mounting location.
- Position the product to be installed into the vehicle and once you are satisfied with the mounting locations, mark the mounting locations. Using a 1-3/16" diameter carpet cutter (P/N: 31183-0). Select the appropriate floor spacers as shown in the illustration. Set those aside for use later into the installation process.
- Using the correct drill bit size for the selected plusnut, drill the mounting holes in the vehicle sheet metal to prepare for installing the plusnuts.
- Once you have drilled the holes into the vehicle, the raw metal edges should be sealed using a self-etching primer to resist corrosion and potential fastener point failure.

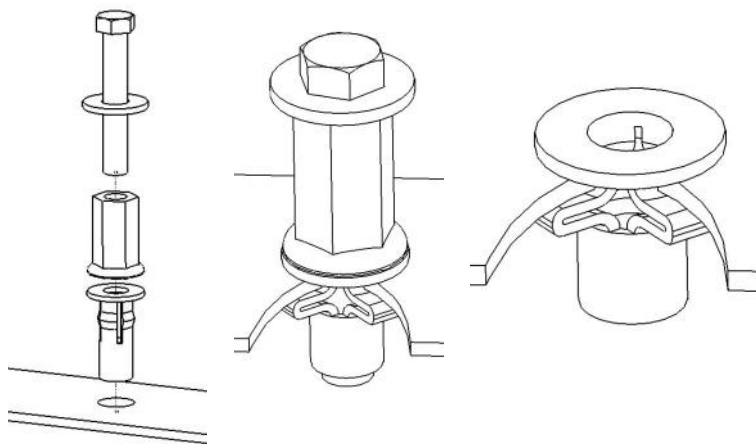

- A PLUSNUT (RIVNUT) SETTING TOOL IS REQUIRED FOR PLUSNUT (RIVNUT) INSTALLATION . PLUS NUT SETTING TOOL CAN BE ORDERED THROUGH ADRIAN STEEL, OR USE AN AIR POWERED PLUSNUT SETTING GUN.
- 5/16-18UNC Plusnut (FAS0091) Use 1/2" dia. drill w/stop
 - FAS0095 SCREW, HXHD, 5/16-18UNCx2.00", G8
 - FAS0086 WASHER, FLAT, 5/16"ID
 - 22200-0 PLUSNUT TOOL
- Place barrel of the plusnut body in sheet metal thru hole until flange is flush with sheet metal.
- Using a 9/16" combination wrench of plusnut tool body and a second hand wrench, ratchet, or air tool, rotate the hex bolt head CW to draw plus nut flanges up (set the plusnut).