

Introduction / Comments:  
**400W, 700W & 1kW Inverter Kit for Ford Transit**

**Please Note:**

1. Read all instructions prior to installation. Review the Adrian Steel **GENERAL PRECAUTIONS PAGES (56638)** before attempting installation. Only personnel familiar with using electrical best practices should perform this install. Reference **ELECTRICAL BEST PRACTICES MANUAL (54479)** before attempting installation.
2. Review order drawings to determine inverter placement.
3. Also if any power strip kits will need to be installed also and their placement.
4. Not all applications will use all the components listed.
5. **These instructions cover Transit with one or two Chassis Batteries (1CB or 2CB).**

For All Ford Transits



400W



700W



1000W



**[66706]**  
**400W, 700W & 1kW Inverter Kit for Ford Transit**

# Section 1: Table of Contents



<b>Table of Contents:</b>	
[700W & 1kW Inverter Kit for Ford Transit]	
Page 1: <u>Cover Page/Introduction</u> .....	<u>1</u>
Section 1: <u>TOC &amp; Safety Precautions information</u> .....	<u>2</u>
Section 2: <u>Cable Kit Part Identification</u> .....	<u>4</u>
Section 3: <u>Tools Needed &amp; Fastener ID/Torque Table</u> .....	<u>8</u>
Section 4: <u>General Vehicle Layout</u> .....	<u>11</u>
Section 5: <u>General Wiring Diagrams</u> .....	<u>13</u>
Section 6: <u>Chassis Battery Wiring</u>	
• <u>Chassis Battery (CB) Access</u> .....	<u>15</u>
• <u>6A: Single Chassis Battery (1CB) CABLE Rtg [KITS 68158, 66008 &amp; 66006]</u> ..	<u>16</u>
• <u>6B: Two Chassis Battery (2CB) CABLE Routing [KITS 62835 &amp; 60323]</u> .....	<u>22</u>
Section 7: <u>Vehicle Integration</u>	
• <u>7A: Vehicle Interface For Non-67C Application [KITS 68158, 66008 &amp; 66006]</u>	
• <u>Locating the Remote Switch</u> .....	<u>27</u>
• <u>Remote Switch Harness Layout</u> .....	<u>28</u>
• <u>Switch Installation</u> .....	<u>30</u>
• <u>Remote Wiring Routing</u> .....	<u>34</u>
• <u>7B: Vehicle Interface For 67C Application [KITS 62835 &amp; 60323]</u>	
• <u>Accessing 43-Way Vehicle Connector</u> .....	<u>38</u>
• <u>Connecting to 43-Way Upfitter Connector</u> .....	<u>41</u>
• <u>67C Remote Wire Routing</u> .....	<u>44</u>
Section 8: <u>Inverter Installation</u>	
• <u>Wire and Cabling</u> .....	<u>47</u>
• <u>Settings</u> .....	<u>49</u>
• <u>Partition/Bracket Mounting</u> .....	<u>50</u>
Section 9: <u>Fuse Installation</u> .....	<u>51</u>
Section 10: <u>Important Labeling</u>	
• <u>Remote switch labels (Yellow)</u> .....	<u>52</u>
• <u>Power switch notice label (Blue)</u> .....	<u>52</u>
• <u>Caution labels/ battery tags</u> .....	<u>53</u>
Section 11: <u>Test and Check</u> .....	<u>54</u>
Section 12: <u>Appendices</u>	
A. <u>FLEET Requested docs (Schematics, tools, Torque table)</u> .....	<u>56</u>

## Section 1: Table of Contents



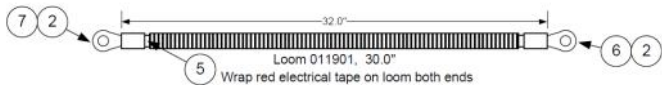
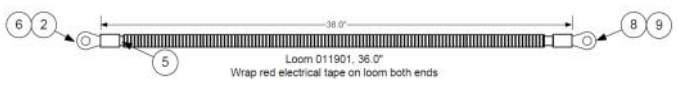
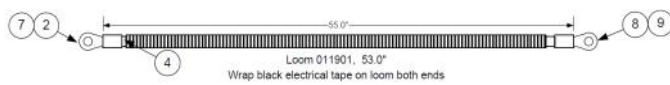
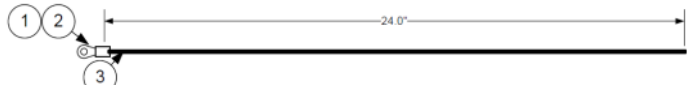
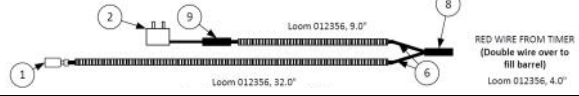
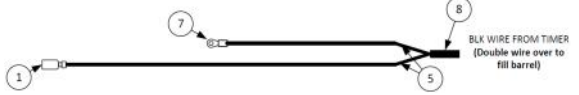
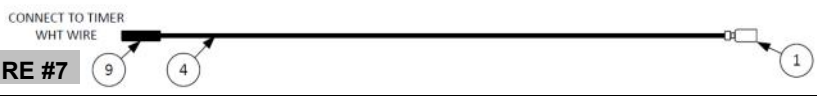
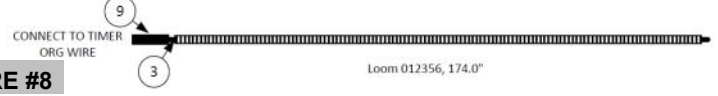

These symbols are used in the document to warn installer to make sure there is understanding beyond general precautions used when working on electrical installations.

	ANSI Z535.6-2006 refers to the use of blue when “addresses practices not related to personal injury”.
	Yellow labelling level of personal injury = could result in minor injury.
	Red labelling level of personal injury = could / will result in death.

## Section 2: Cable Kit Part Identification [KIT 68158: 400W]:

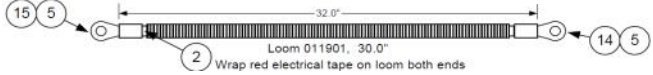
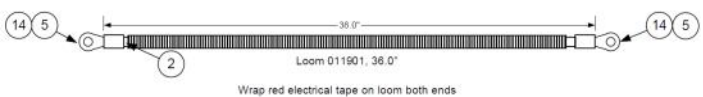
Part Description & Label	Part Photo/Diagram
Kit PPDS Photo [Example: 68158: 400W]: <ul style="list-style-type: none"> <li>• Harness wires #1-#8,</li> <li>• Fuse,</li> <li>• Fuse holder,</li> <li>• Fuse holder Bracket,</li> <li>• Switch and Timer Harness Kit</li> <li>• Misc. Wire ties and fasteners</li> </ul>	
OEM Battery POSITIVE to FUSE cable <b>“WIRE #1”</b> - 32”, RED, Black Corrugate, POSITIVE	<b>WIRE #1</b> 
FUSE to Inverter cable <b>“WIRE #2”</b> - 38”, RED, Black Corrugate, POSITIVE	<b>WIRE #2</b> 
OEM Battery Negative cable to INVERTER <b>“WIRE #3”</b> - 55”, BLACK, Black Corrugate, NEGATIVE	<b>WIRE #3</b> 
INVERTER GROUNDING WIRE to Chassis, <b>“WIRE #4”</b> - 24”, GREEN wire, GROUND	<b>WIRE #4</b> 
ADD-A-FUSE WIRE to SWITCH and TIM- ER, <b>“WIRE #5”</b> - RED wire, Black Corru- gate, HAAT	<b>WIRE #5</b> 
GROUND WIRE to SWITCH and TIMER, <b>“WIRE #6”</b> - BLACK wire, GROUND	<b>WIRE #6</b> 
REMOTE SWITCH to TIMER <b>“WIRE # 7”</b> - WHITE wire, Black Corrugate, Switch Signal	<b>WIRE #7</b> 
TIMER to INVERTER <b>“WIRE # 8”</b> - OR- ANGE wire, Black Corrugate, Remote Sig- nal	<b>WIRE #8</b> 
Vanner Remote Switch and Timing circuit	

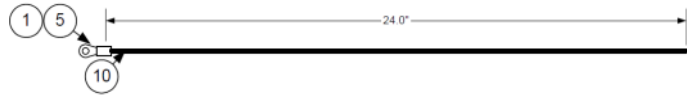
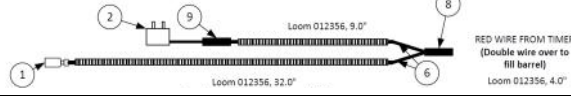
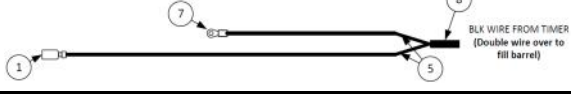
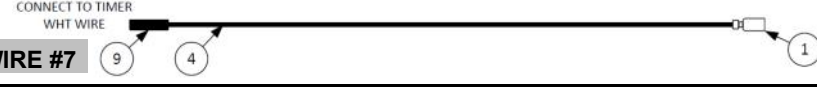
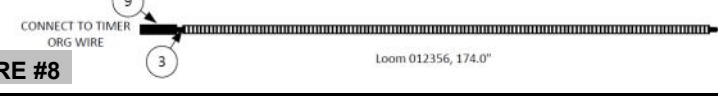

## Section 2: Cable Kit Part Identification [KIT 66008: 700W]:

Part Description & Label	Part Photo/Diagram
Kit PPDS Photo [Example: 66008: 700W]: <ul style="list-style-type: none"> <li>• Harness wires #1-#8,</li> <li>• Fuse,</li> <li>• Fuse holder,</li> <li>• Fuse holder Bracket,</li> <li>• Switch and Timer Harness Kit</li> <li>• Misc. Wire ties and fasteners</li> </ul>	
OEM Battery POSITIVE to FUSE cable <b>“WIRE #1”</b> - 32”, RED, Black Corrugate, POSITIVE	<b>WIRE #1</b> 
FUSE to Inverter cable <b>“WIRE #2”</b> - 38”, RED, Black Corrugate, POSITIVE	<b>WIRE #2</b> 
OEM Battery Negative cable to INVERTER <b>“WIRE #3”</b> - 55”, BLACK, Black Corrugate, NEGATIVE	<b>WIRE #3</b> 
INVERTER GROUNDING WIRE to Chassis, <b>“WIRE #4”</b> - 24”, GREEN wire, GROUND	<b>WIRE #4</b> 
ADD-A-FUSE WIRE to SWITCH and TIM- ER, <b>“WIRE #5”</b> - RED wire, Black Corru- gate, HAAT	<b>WIRE #5</b> 
GROUND WIRE to SWITCH and TIMER, <b>“WIRE # 6”</b> - BLACK wire, GROUND	<b>WIRE #6</b> 
REMOTE SWITCH to TIMER <b>“WIRE # 7”</b> - WHITE wire, Black Corrugate, Switch Signal	<b>WIRE #7</b> 
TIMER to INVERTER <b>“WIRE # 8”</b> - OR- ANGE wire, Black Corrugate, Remote Sig- nal	<b>WIRE #8</b> 
Vanner Remote Switch and Timing circuit	

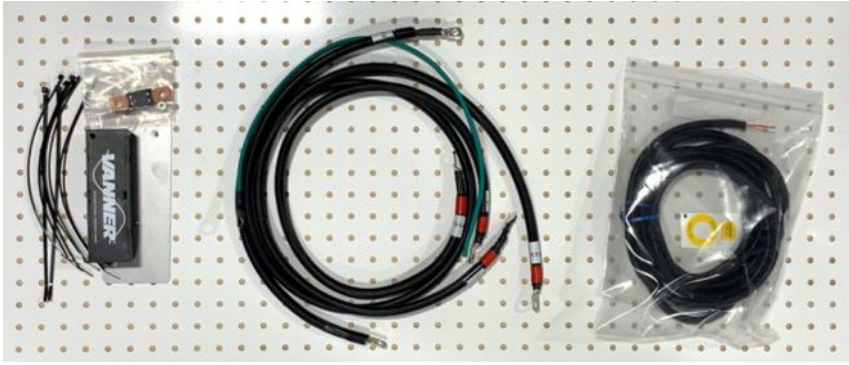
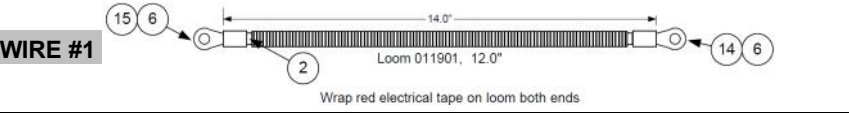
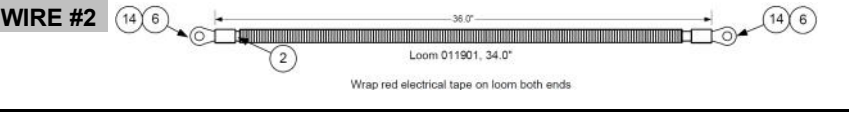
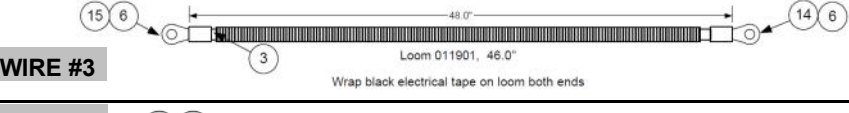
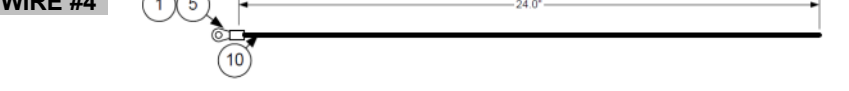
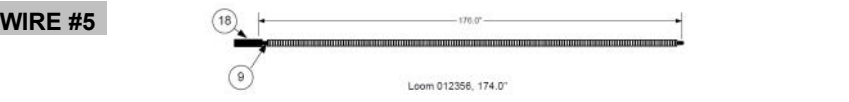
## Section 2: Cable Kit Part Identification [KIT 62835: 700W-67C]:

Part Description & Label	Part Photo/Diagram
Kit PPDS Photo [Example: 62835: 700W]: <ul style="list-style-type: none"> <li>• Harness wires #1-#5,</li> <li>• Fuse,</li> <li>• Fuse holder,</li> <li>• Fuse holder Bracket,</li> <li>• Switch and Timer Harness Kit</li> <li>• Misc. Wire ties and fasteners</li> </ul>	
OEM Battery POSITIVE to FUSE cable <b>"WIRE #1"</b> - 14", RED, Black Corrugate, POSITIVE	
FUSE to Inverter cable <b>"WIRE #2"</b> - 36", RED, Black Corrugate, POSITIVE	
OEM Battery Negative cable to INVERTER <b>"WIRE #3"</b> - 48", BLACK, Black Corrugate, NEGATIVE	
INVERTER GROUNDING WIRE to Chassis, <b>"WIRE #4"</b> - 24", GREEN wire, GROUND	
TIMER to INVERTER <b>"WIRE # 5"</b> - OR-ANGE wire, Black Corrugate, Remote Signal	

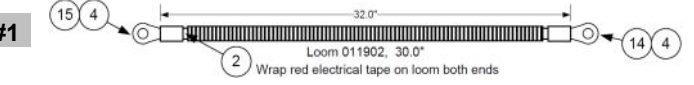
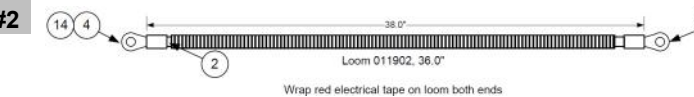
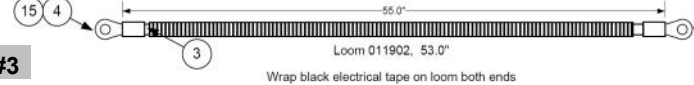
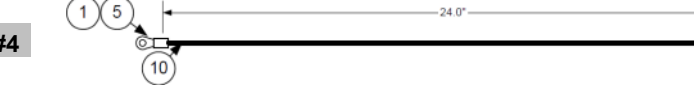
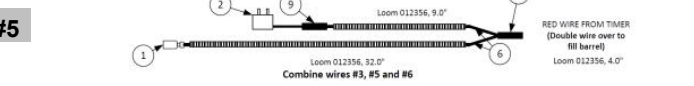
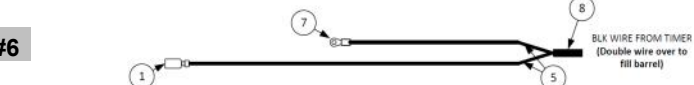
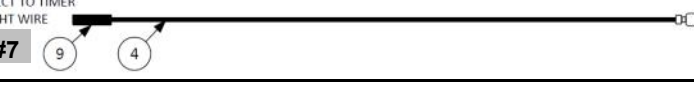
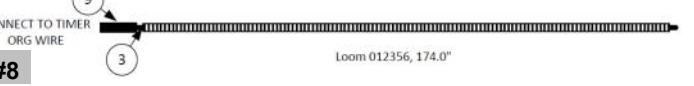
## Section 2: Cable Kit Part Identification [KIT 66006: 1.0kW]:

Part Description & Label	Part Photo/Diagram
Kit PPDS Photo [Example: 66006: 1.0kW]: <ul style="list-style-type: none"> <li>• Harness wires #1-#8,</li> <li>• Fuse,</li> <li>• Fuse holder,</li> <li>• Fuse holder Bracket,</li> <li>• Switch and Timer Harness Kit</li> <li>• Misc. Wire ties and fasteners</li> </ul>	
OEM Battery POSITIVE to FUSE cable <b>"WIRE #1"</b> - 32", RED, Black Corrugate, POSITIVE	<b>WIRE #1</b> 
FUSE to Inverter cable <b>"WIRE #2"</b> - 38", RED, Black Corrugate, POSITIVE	<b>WIRE #2</b> 
OEM Battery Negative cable to INVERTER <b>"WIRE #3"</b> - 55", BLACK, Black Corrugate, NEGATIVE	<b>WIRE #3</b> 
INVERTER GROUNDING WIRE to Chassis, <b>"WIRE #4"</b> - 24", GREEN wire, GROUND	<b>WIRE #4</b> 
ADD-A-FUSE WIRE to SWITCH and TIMER, <b>"WIRE #5"</b> - RED wire, Black Corrugate, HAAT	<b>WIRE #5</b> 
GROUND WIRE to SWITCH and TIMER, <b>"WIRE #6"</b> - BLACK wire, GROUND	<b>WIRE #6</b> 
REMOTE SWITCH to TIMER <b>"WIRE # 7"</b> - WHITE wire, Black Corrugate, Switch Signal	<b>WIRE #7</b> 
TIMER to INVERTER <b>"WIRE # 8"</b> - ORANGE wire, Black Corrugate, Remote Signal	<b>WIRE #8</b> 
Vanner Remote Switch and Timing circuit	

## Section 2: Cable Kit Part Identification [KIT 60323:1.0 kW-67C]:

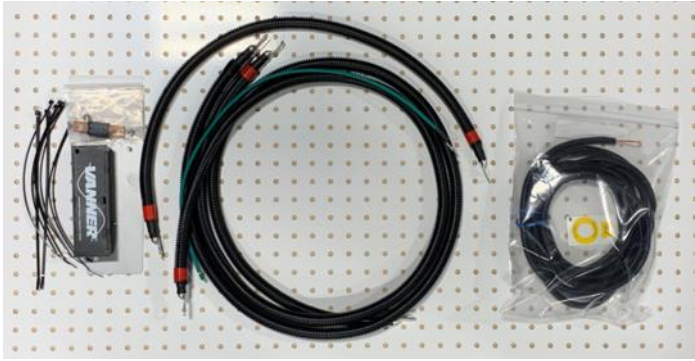
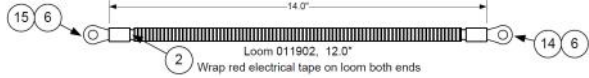
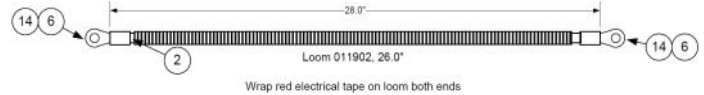
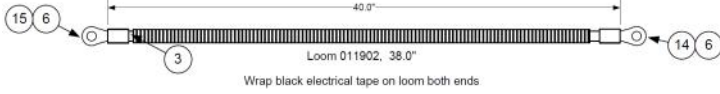
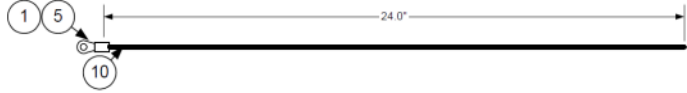
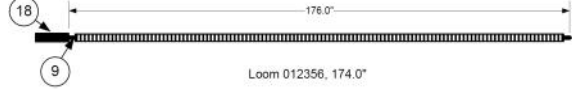
Part Description & Label	Part Photo/Diagram
Kit PPDS Photo [Example: 60323:1.0 kW]: <ul style="list-style-type: none"> <li>• Harness wires #1-#5,</li> <li>• Fuse,</li> <li>• Fuse holder,</li> <li>• Fuse holder Bracket,</li> <li>• Misc. Wire ties and fasteners</li> </ul>	
OEM Battery POSITIVE to FUSE cable <b>“WIRE #1”</b> - 14”, RED, Black Corrugate, POSITIVE	<b>WIRE #1</b> 
FUSE to Inverter cable <b>“WIRE #2”</b> - 28”, RED, Black Corrugate, POSITIVE	<b>WIRE #2</b> 
OEM Battery Negative cable to INVERTER <b>“WIRE #3”</b> - 40”, BLACK, Black Corrugate, NEGATIVE	<b>WIRE #3</b> 
INVERTER GROUNDING WIRE to Chassis, <b>“WIRE #4”</b> - 24”, GREEN wire, GROUND	<b>WIRE #4</b> 
TIMER to INVERTER <b>“WIRE # 5”</b> - 174”, ORANGE wire, Black Corrugate, Remote Signal	<b>WIRE #5</b> 

## Section 3: Tools Needed & Fastener ID/Torque Table:



1. Insulated Splice Crimper
2. Wire Strippers
3. Diagonal Cutters
4. Plastic Trim Tool
5. Drill driver
6. Measuring tape
7. Phillips Bit with Bit holder
8. 3/4" Hole or Step Drill (Unibit)
9. Medium and Small (-) Screwdriver
10. Large #3 Phillips (+) Screwdriver
11. Sockets:
  - 8mm
  - 10mm
  - 5/16"
  - 3/8"
  - 7/16"
  - 1/2"
  - 13mm
  - Socket driver and extensions
12. Torque Wrench [~8-20Nm range]
13. Tin Snips
14. #3 Philips (+) & Medium slotted torque socket
15. Marker [Not Shown]

Figure 3-1: Tools Needed for Installation

## Section 3: Tools Needed & Fastener ID/Torque Table:

ITEM NO.	ASC PN	Description	PCS	Torque Range	Use Wrench or
1	BAG0406-A	4" x 6" 3MIL AUTOBAG	1	--	
2	FAS0055	Nut, Hex Flange, Nylock 1/4-20	4	12Nm [+/- 1.8Nm] (106lb.in).	7/16"
3	FAS0018	SCREW, HH SFLNG 1/4-20X.62 ZP	4	12Nm [+/- 1.8Nm] (106lb.in).	7/16"
4	FAS0159	NUT, HEX TPLK M6X1.0	2	8Nm [+/- 1.2Nm] (71l b.in).	10mm
5	FAS0148	Screw, Self Drill/Tap, Pan Ph. Hd., #10x0.5, NI-ZN	1	3Nm [+/- 0.5Nm] (27lb.in).	#2 Phillips

Figure 3-2: Fasteners included in Kit

BAG66613

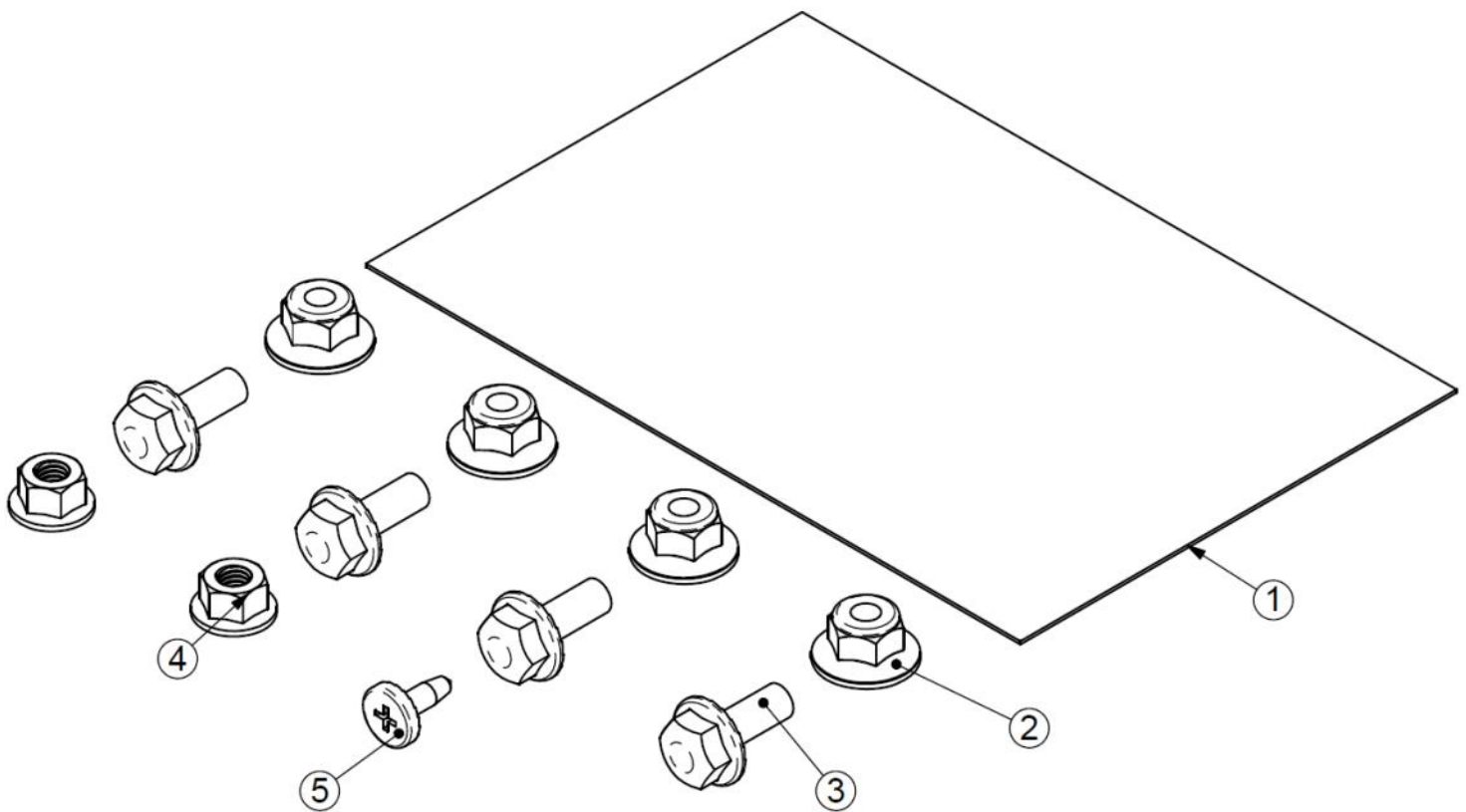

Figure 3-3: Fasteners Diagram

**Please NOTE: Certain fasteners or hardware may not be used for certain kits.**

## Section 3: Tools Needed & Fastener ID/Torque Table:



Ref. NO.	ASC PN	Description	PCS	Torque Range	Use Wrench or Size
6	Positive Battery Terminal busbar		1	8Nm [+/- 1.2Nm] (71 lb.in).	5/16"
7	Positive Battery Terminal busbar		1	-Will USE FAS0159 will be 8Nm [+/- 1.2Nm] (71 lb.in).	—
8	Cables to VANNER Fuse Holder		4	12Nm [+/- 1.8Nm] (106lb.in).	1/2"
9	Chassis Battery Fuse Holder to bracket nuts [KEPS]		2	3Nm [+/- 0.5Nm] (27lb.in).	3/8"
10	Inverter +/- Terminals	Phillips and slotted screws	Three (3) Positions	8Nm [+/- 1.2Nm] (71l b.in).	#3 Phillips and 1/4" Standard driver bits
<b>Other Fasteners in Vehicle</b>					
11	CB Positive Battery Post Clamp	—	1	8Nm [+/- 1.2Nm] (71 lb.in).	10mm NUT
12	CB Negative Battery Cable to Battery Clamp	—	1	8Nm [+/- 1.2Nm] (71 lb.in).	13mm Nut
13	AUX positive and negative terminal fasteners	—	2 or 4	8Nm [+/- 1.2Nm] (71 lb.in).	1/2" Nut
14	Fuse holder & Battery Hold Down Bracket	—	2	10Nm [+/- 1.5Nm] (89 lb.in).	8mm Screw

Figure 3-4: Other Fasteners

**Please NOTE: Certain fasteners or hardware may not be used for certain kits.**

**Section 4: General Vehicle Layout—1 CB [KITS 68158, 66006 & 66008]:**

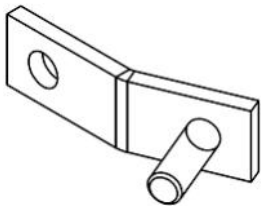

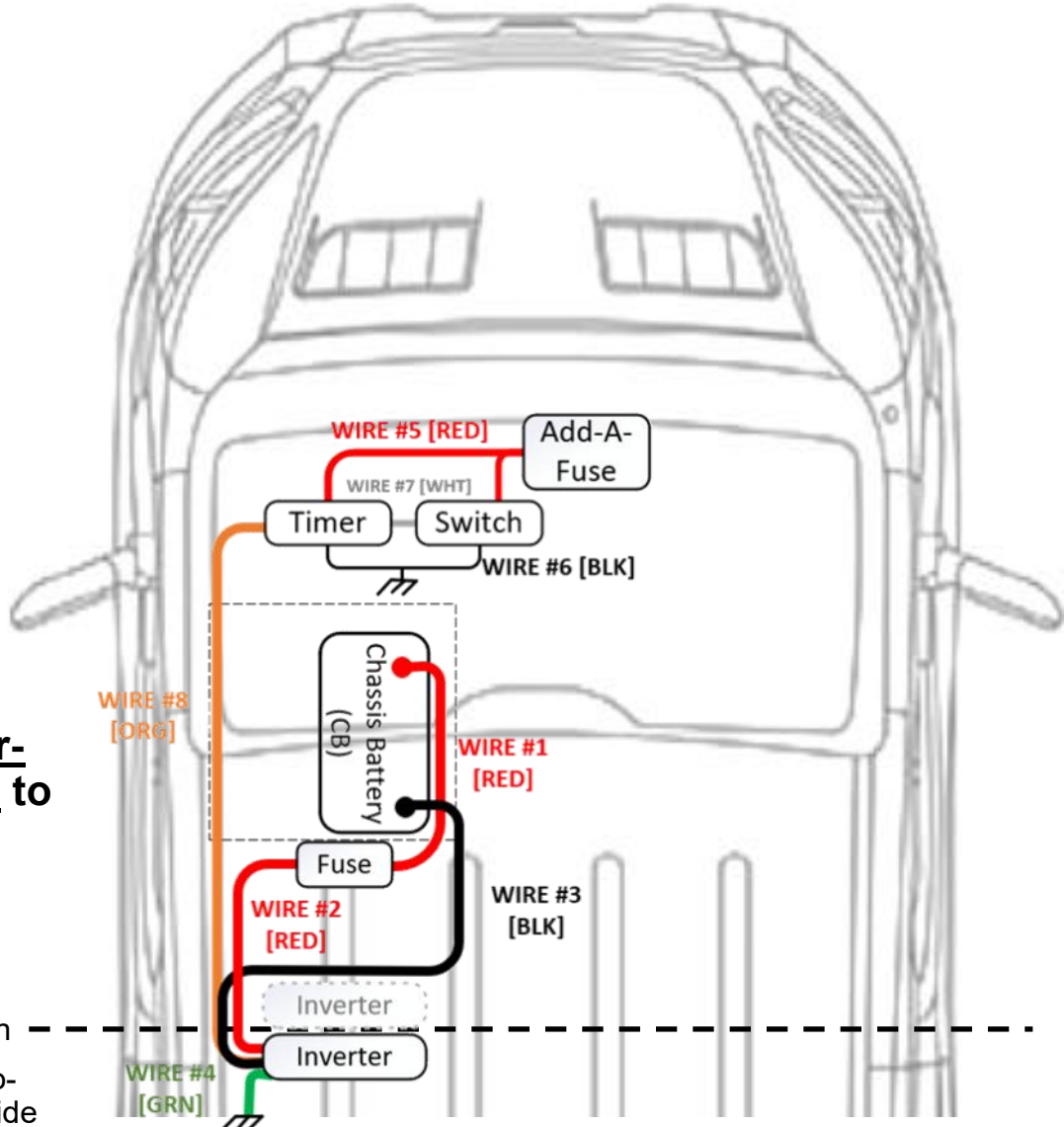
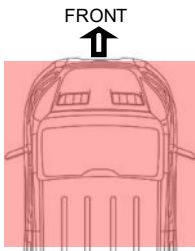
- **Use sales order drawing to place all equipment.**

- Inverter can be located on either side of the partition.

Figure 4-1: Transit NON-67C Diagram [Top]

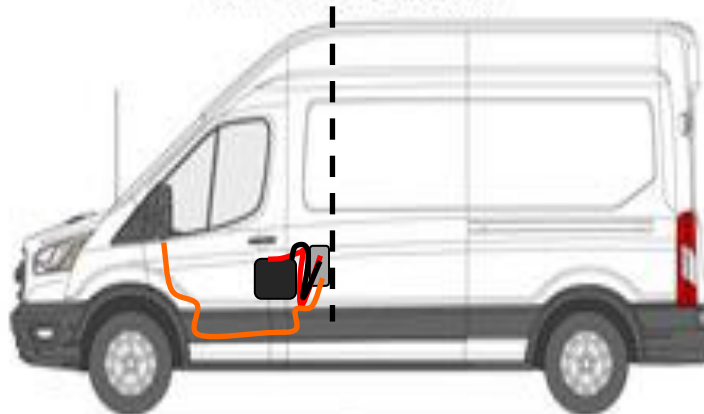
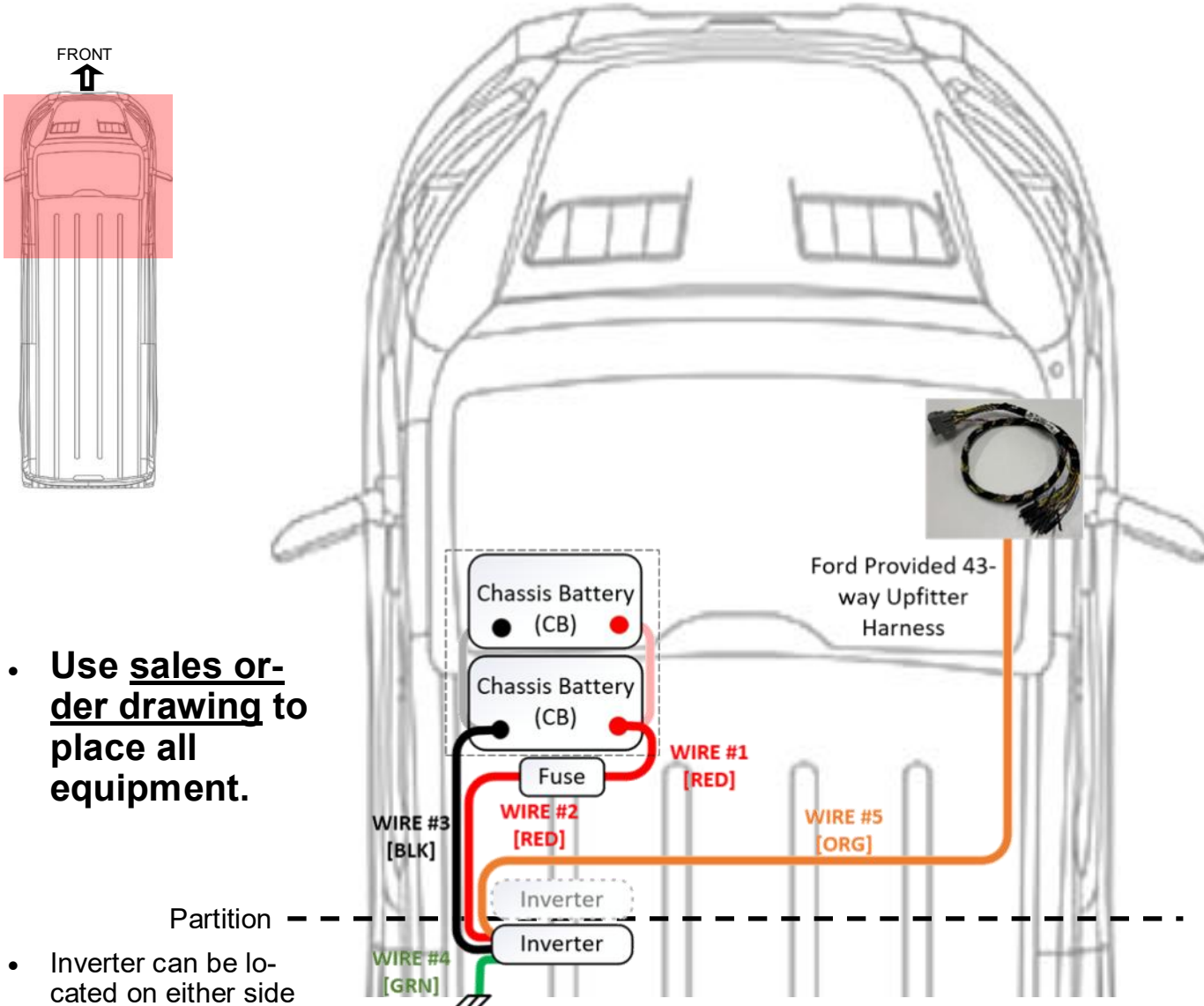

Figure 4-2: Transit NON-67C Diagram [side]

**Section 4: General Vehicle Layout—2 CB [KITS 60323 & 62835]:**



- **Use sales order drawing to place all equipment.**

- Inverter can be located on either side of the partition.

Figure 4-1: Transit 67C Diagram [Top]

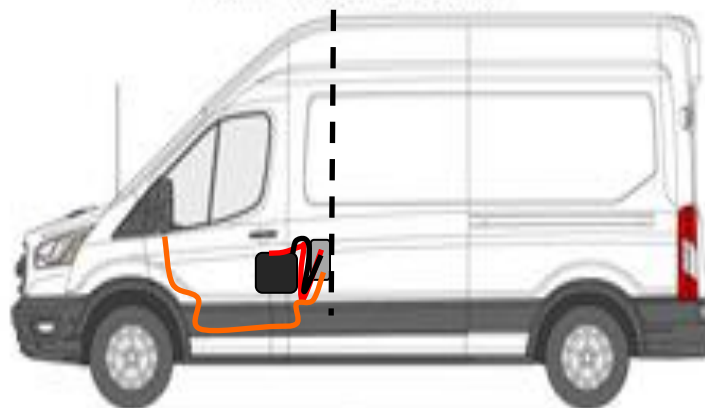

Figure 4-2: Transit 67C Diagram [side]

## Section 5: General Wiring Diagrams:

### NON-67C Wiring Diagram 1 CB [KITS 68158, 66006 & 66008]:

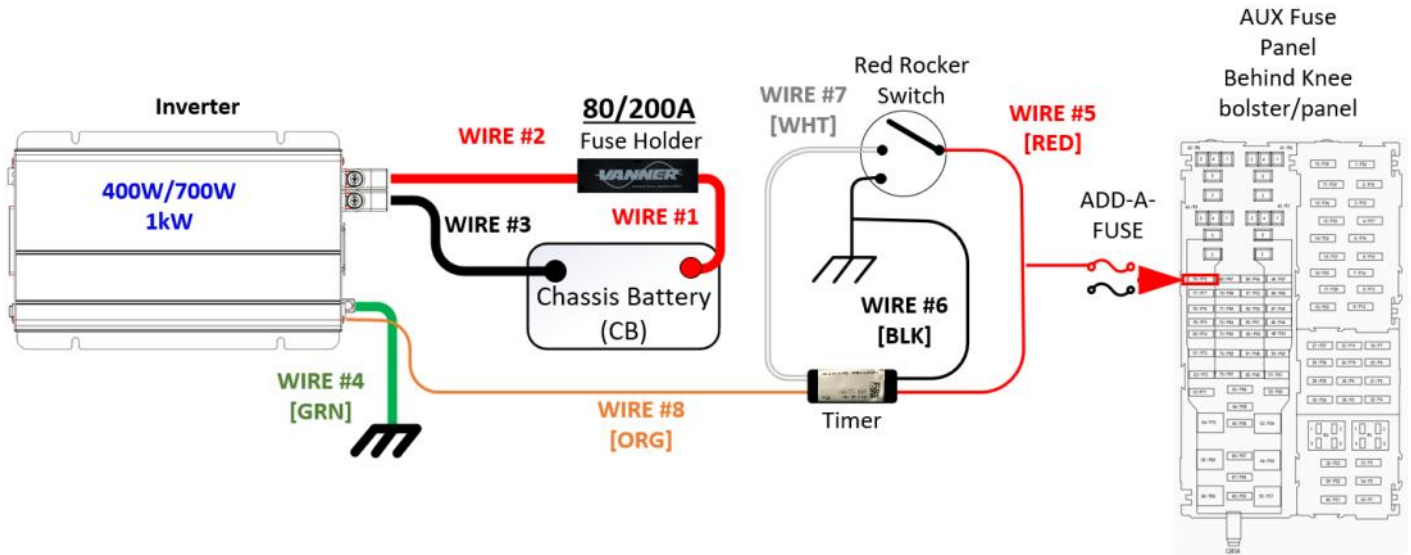

Figure 5-1: Complete Wiring Diagram [NON-67C Option KITS 68158, 66008 & 66006]

**NOTE:** New Fuse Box shape (on Pg.16) and fuse locations for MDY2026 and beyond.

### 67C Wiring Diagram 2CB [KITS 60323 & 62835]:

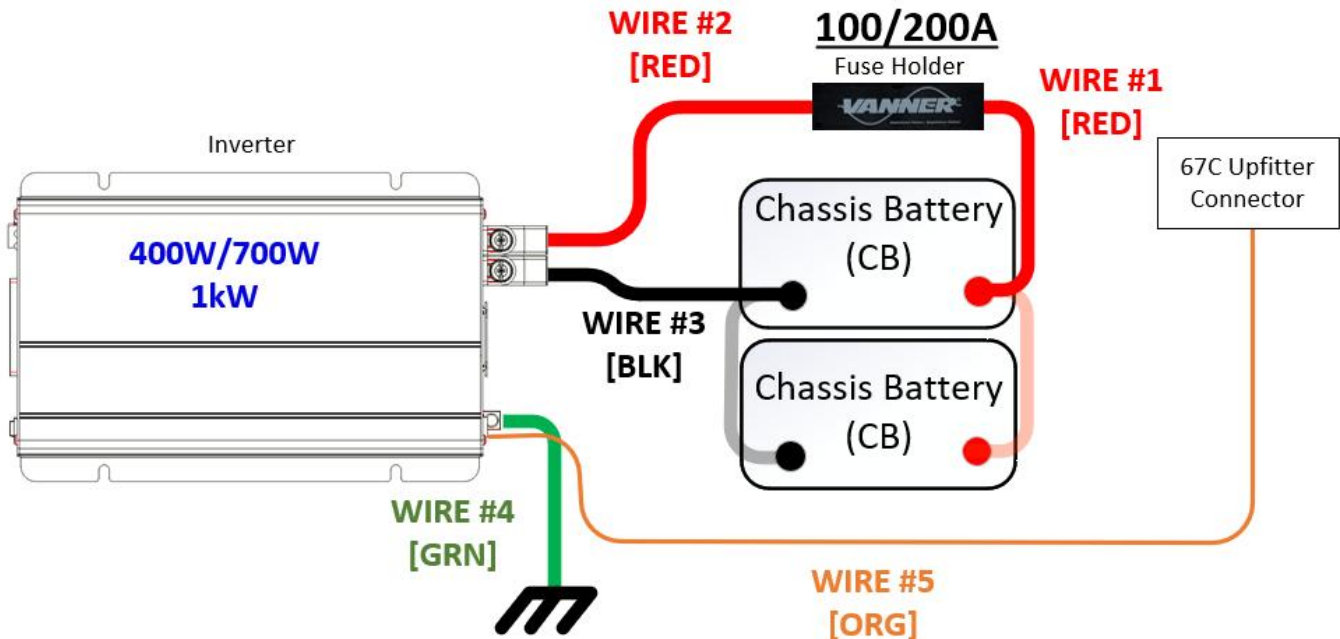
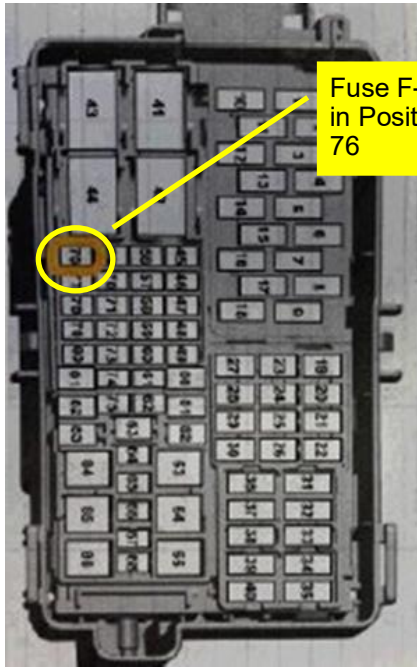
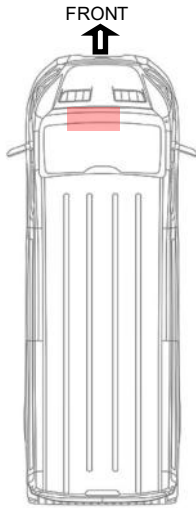

Figure 5-2: Complete Wiring Diagram [67C Option KITS 62835 & 60323]

**For Model Year 2026+ Fuse Panel Add-a-Fuse Location, see next page**

## Section 5: General Wiring Diagrams:

### Fuse Panel: Add-A-Fuse location [KITS 68158, 66008 & 66006]



Fuse F-78, in Position 76

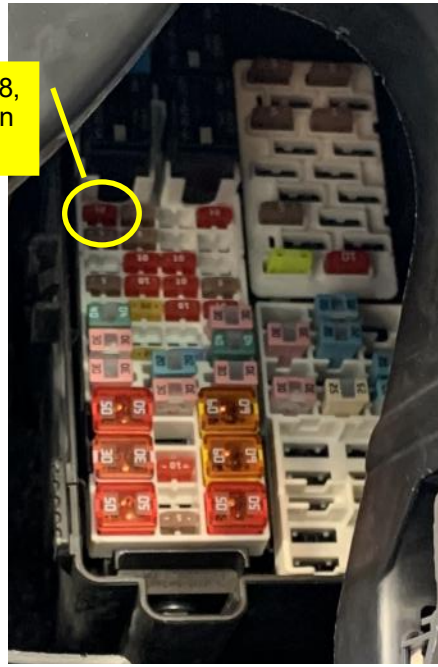

Figure 5-3: Fuse Panel Diagram

Figure 5-4: Fuse Panel Photo

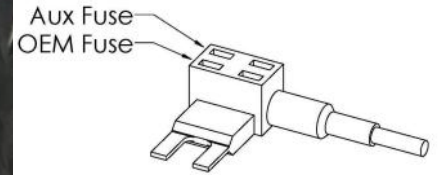

Figure 5-5: Diagram of Add-A-Fuse

- The Fuse Panel is located behind the knee bolster and can be accessed after bolster removal step.

### Fuse Panel: 67C Option Switch power source location [KITS 62835 & 60323]

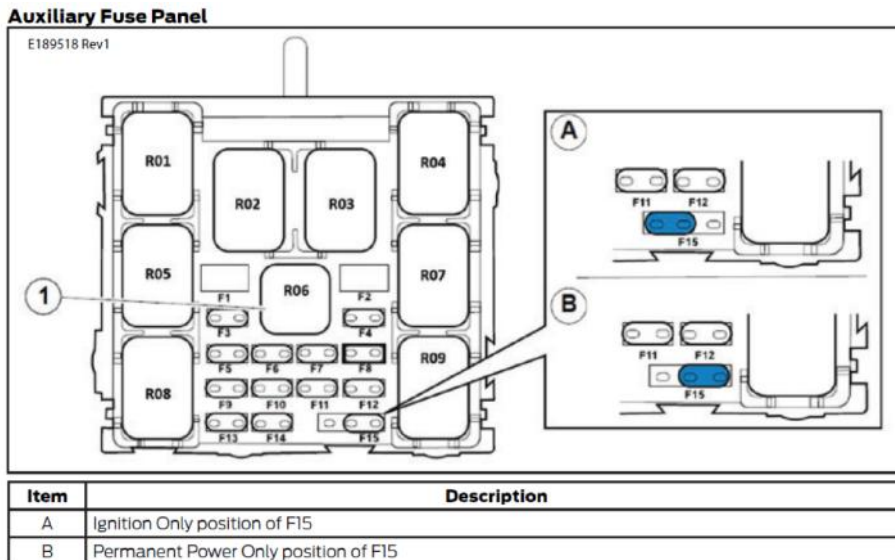
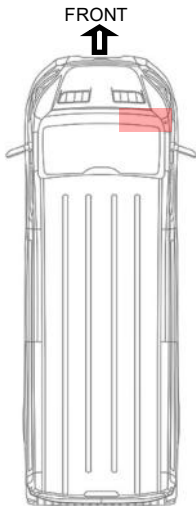

Figure 5-5: Option 67C Auxiliary Fuse Panel

- The Auxiliary Fuse Panel is located behind the glove box and can be accessed after glove box removal step.
- Move fuse 15 to position labeled "B" to the blue Permanent power only position in Figure 5-5 to the left.

## Model Year 2026+

### Fuse Panel Add-a-Fuse Location

Note: New Fuse Box shape for 2026 and beyond. Same fuse locations with or without 67C.

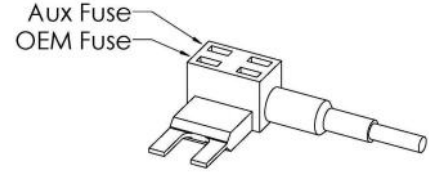
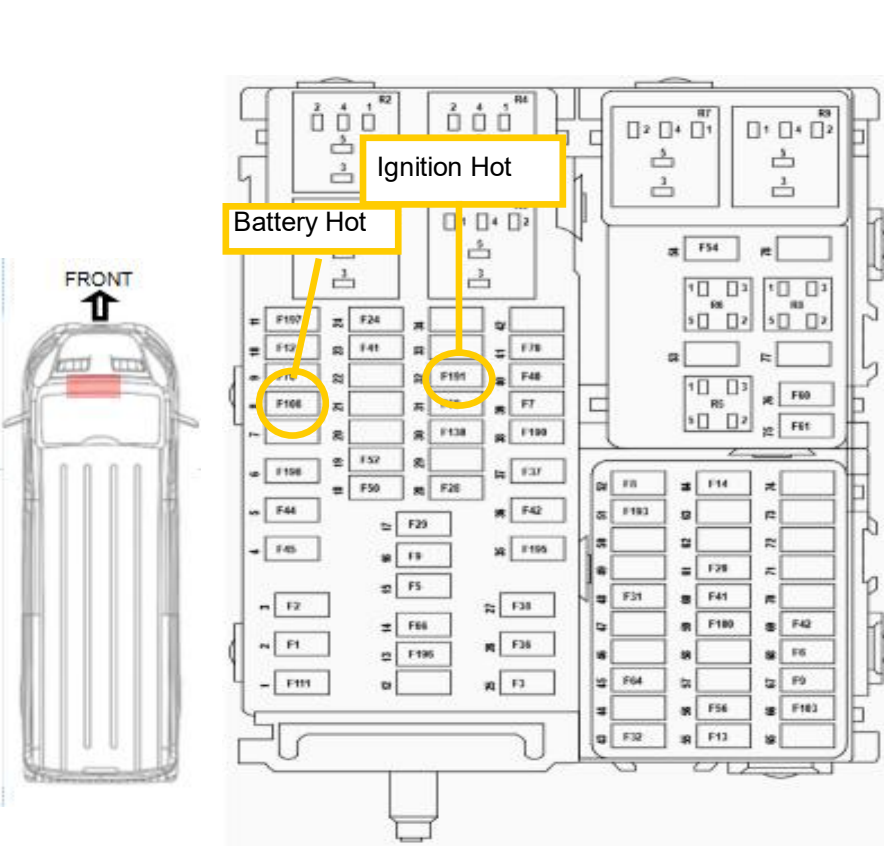

- The Fuse Panel is located behind the knee bolster and can be accessed after bolster removal step.
- Position 32 F191 is 10A Ignition hot.
- Position 8 F108 is Battery hot.

Without 67C

With 67C

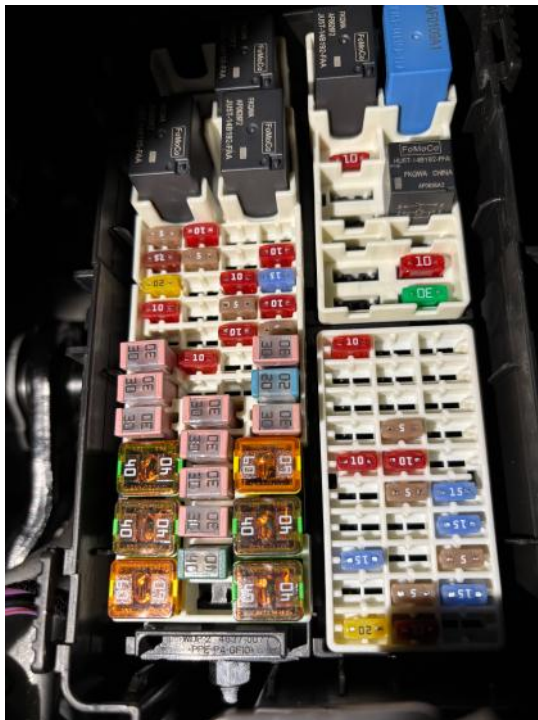

## Section 6: Chassis Battery (CB) Access:

### Step 6-1. Remove Carpet Strip Behind Drivers Seat

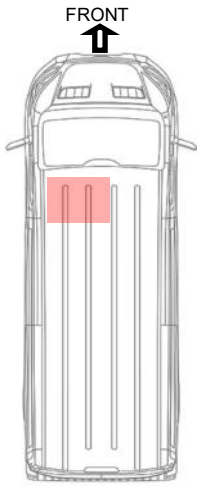

- Move the driver's seat fully forward and adjust to highest height if possible.
- Remove carpet strip if present [Yellow Arrow].
- It mounts with plastic fasteners in holes. A plastic trim tool may help to pry out the fasteners that hold down the carpet strip.

### Step 6-2. Remove Loom Clipped to T-Bracket



- Remove clip holding a wire loom leaving the battery box.
- The same loom's grommet will be able to slide out as the bracket is being removed.

### Step 6-3. Remove Rear T-Bracket Fasteners

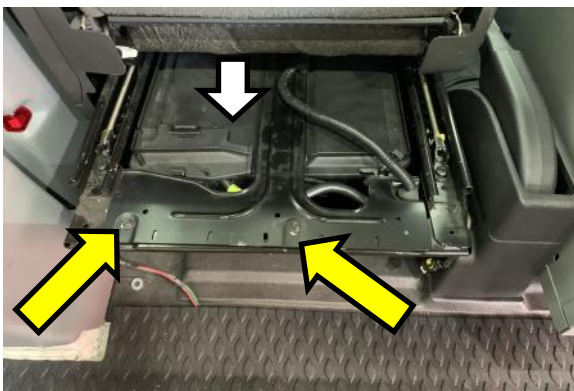

- Remove both T-bracket fasteners as shown (Yellow Arrows) at the rear of the seat [8mm or 10mm socket].
- Remove the steel T-bracket by pulling rearward.
- Remove the battery compartment (White Arrow) . Carefully remove clips retaining the plastic cover and remove to gain access to the battery terminals.

**Section 6A: Single Chassis Battery (1CB) CABLE Routing [KITS 68158, 66008 & 66006]**

**Step 6A-1. Identify Correct Lug Hole Diameters**

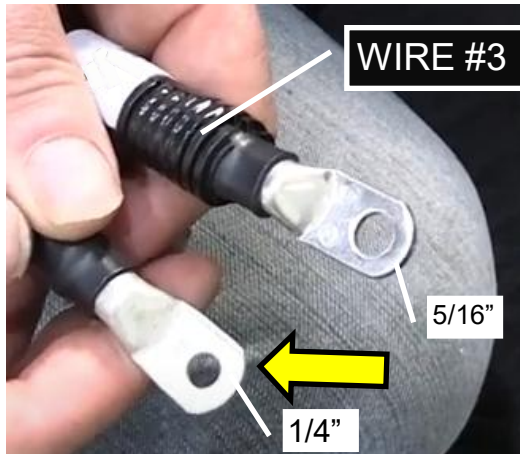
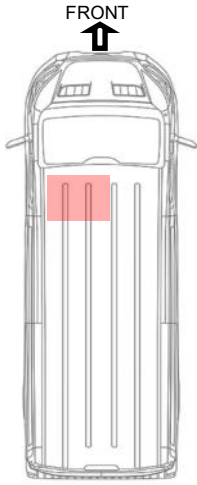

- Observe both ends of **WIRE #3**.
- One end has a 1/4" hole in the terminal, the other end has a 5/16" hole in the terminal.
- The 1/4" hole lug will be installed onto the terminal on the CB negative battery clamp.

**Step 6A-2. Wire #3 to the Negative Battery Post**



Caution: Control this negative cable, place the free end away from the battery(ies). Tape off free end if possible.

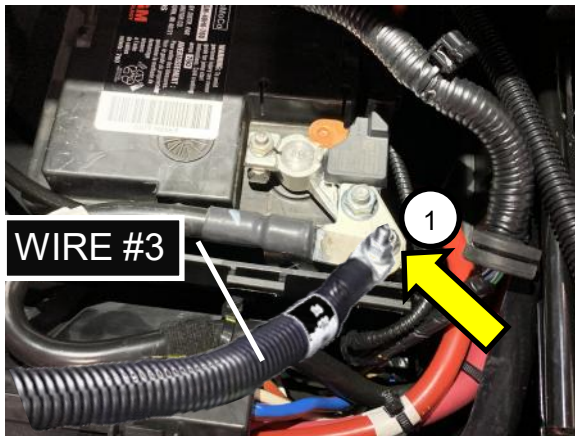

- Remove the nut on the battery ground [See Yellow Arrow] and install **WIRE #3** [1/4" lug terminal] onto this smaller terminal.
- 1 Torque the **WIRE #3** to 8Nm [+/- 1.2Nm] (71lb.in) with 10mm socket

**Step 6A-3. Mount the MEGA Fuse Holder to Plate**



Do not torque down the KEPS nuts. It may split the plastic. Hand tighten firm (~4Nm /36in lb.).

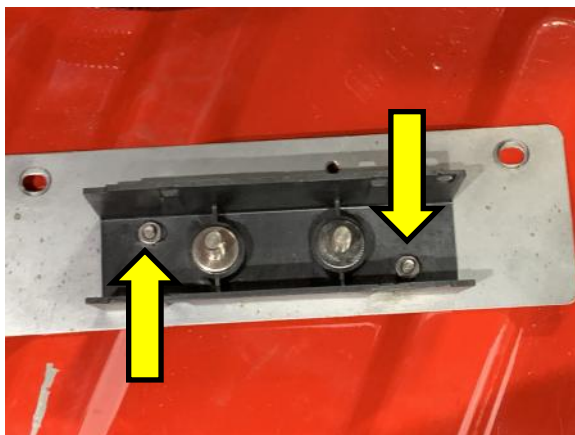

- Remove the cover and parts from the Vanner MEGA fuse holder.
- Assemble the flat washer, split washer, and then nuts on the terminals for safe keeping (or set aside).
- Place the bottom portion on the metal plate bracket included in the kit.
- Fasten down [KEPS nuts (Ref. NO.: 9)] with nut with serrated washers. Use 3/8" nut driver and ensure they are snug.

**Section 6A: Single Chassis Battery (1CB) CABLE Routing [KITS 68158, 66008 & 66006]**

**Step 6A-4. Connect WIRE #1 to Fuse Holder**

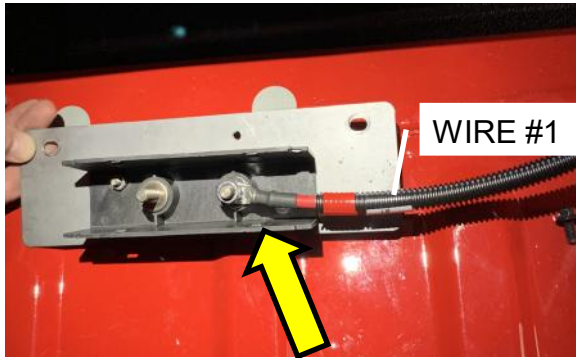
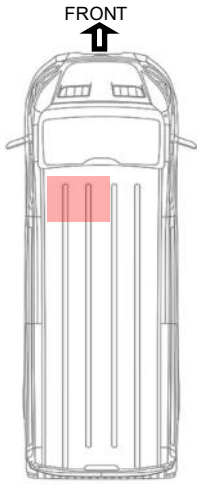

Caution: The fuse holder protects the end of the WIRE #1 from grounding

- **NOTE: WIRE #1** has 1/4" and 5/16" lug similar to **WIRE #3**.
- Connect the end of **WIRE #1** with the 5/16 hole to the empty fuse lug as shown (Terminal to the right).
- Gently tighten fuse nut to hold cable onto stud. (Use 1/2" Nut driver)
- This wire is secured against grounding.
- For extra protection replace the snap fit Vanner cover temporarily.

**Step 6A-5. Prepare Positive Battery Terminal**

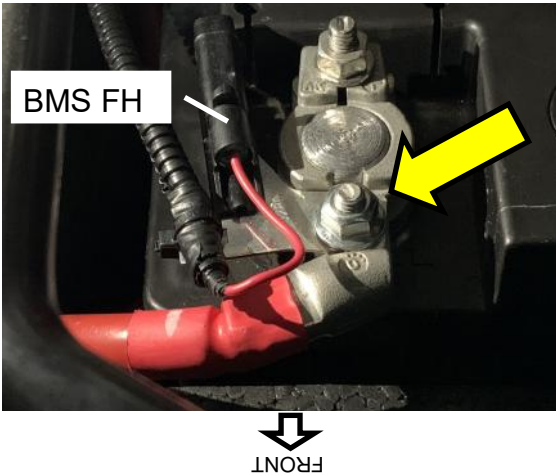
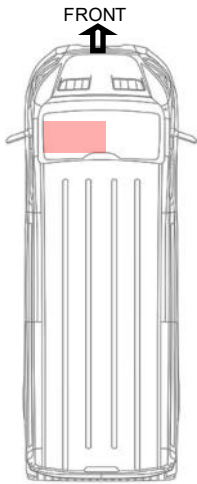

- Move the seat carefully rear-ward so that positive (+) battery terminal can be accessed.
- Loosen nut [see Yellow Arrow] and remove BMS fuse holder (FH) fastener
- From the back of the seat, pull the 1/4" lug of **WIRE #1** near the positive post.

**Step 6A-6. Prepare Busbar**



- The 1/4" hole end of **WIRE #1** and the BMS fuse holder will attach to this busbar (Ref. NO.:17) terminal [at Yellow Arrow] (using FAS0159).
- The busbar will be connected to the terminal on the positive battery clamp (See Blue Arrow).

**Section 6A: Single Chassis Battery (1CB) CABLE Routing [KITS 68158, 66008 & 66006]**

**Step 6A-7. Connection to Busbar**

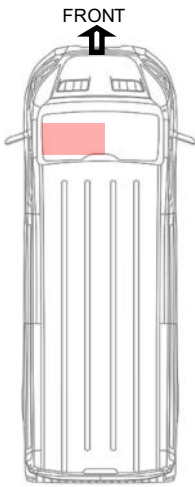

- Use the supplied FAS0159 nut, connect **WIRE#1** and the BMS fuse holder to the busbar terminal.
- The busbar is prepared to be assembled onto the battery clamp terminal.
- Leave the fasteners finger tight for adjustment and tightening in next step.

**Step 6A-8. Attach the Busbar**



Caution: Use high caution or insulated wrenches when tightening on battery post!



- The busbar assembled with the wires is placed onto the terminal on the battery clamp.
- 1 Torque the busbar to battery clamp to 8Nm [+/- 1.2Nm] (71lb.in) with 10mm Socket.
  - 2 Torque the **WIRE #1** and BMS fuse holder on the busbar to 8Nm [+/- 1.2Nm] (71lb.in) with 10mm Socket.

**Step 6A-9. Neatly Route WIRE #1**

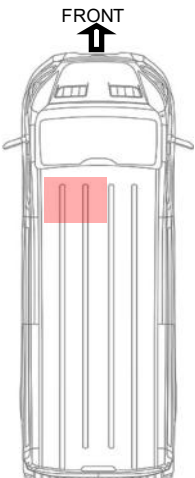

- Push the seat all the way forward and go to area behind the seat.
- The **WIRE #1** battery cable will be pushed, routed and tucked straight back into the space between the battery and the plastic battery bin.

**Section 6A: Single Chassis Battery (1CB) CABLE Routing [KITS 68158, 66008 & 66006]**

**Step 6A-10. Replace Plastic Battery Cover**

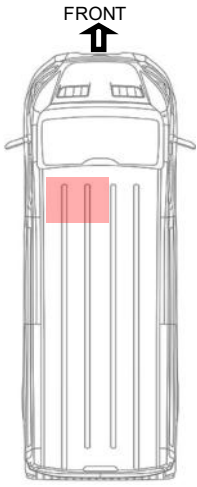

- The cover will slide in and snap onto the plastic battery box.
- The small plastic negative battery post cover is removed so that it may be notched.

**Step 6A-11. Notch Battery Cover for Cables**



- A pair of tin snips can be used to cut the notch in the cover so that the thick cable may exit the battery area when the covers are in place.

**Step 6A-12. Steel T- Bracket Installation**



Caution: The battery is secured by this bracket— position properly.

- Replace the T-bracket
- Make sure the leading edge [Yellow Arrow] of bracket is secured in the correct location beneath the edge of the front of the seat base.

**Section 6A: Single Chassis Battery (1CB) CABLE Routing [KITS 68158, 66008 & 66006]**

**Step 6A-13. Steel T- Bracket Installation**



Caution: The battery is secured by this bracket— position properly.

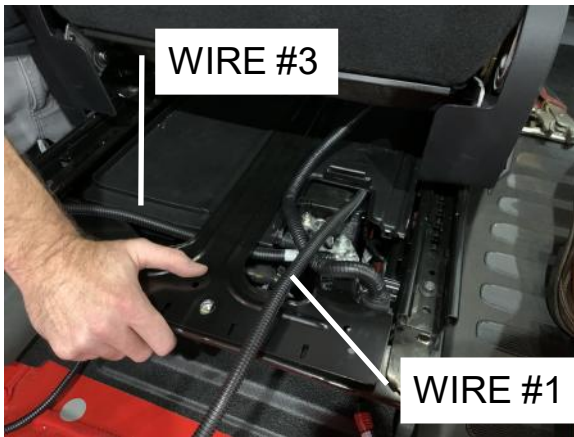
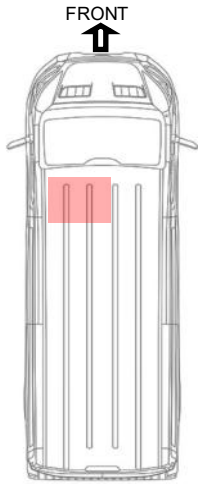

- The T-bracket is pushed forward and the two wires [**WIRE #1 & WIRE #3**] are brought/ routed above the bracket.
- The other loom is then pushed back into the grommet slot on the T-bracket.

**Step 6A-14. Neatly Route Cables**

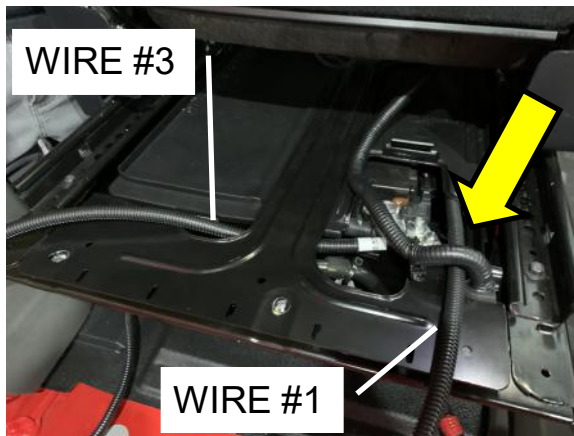

- The **WIRE #1** fits well under the corrugated harness (Yellow arrow pointing at loop). This harness is pushed into groove on steel bracket and clipped at the edge opposite the groove.
- Make sure **WIRE #3** is routed out from under to above the bracket.

**Step 6A-15. Re-install Negative Battery Post Cover**



- Loosely reposition the plastic Negative Battery Post cover to locate where notch shall be for **WIRE#3**.
- Cut or trim notch in plastic cover so that it can snap in with **WIRE #3** present.

**Section 6A: Single Chassis Battery (1CB) CABLE Routing [KITS 68158, 66008 & 66006]**

**Step 6A-16. Fasten WIRE #2 to Fuse Holder**

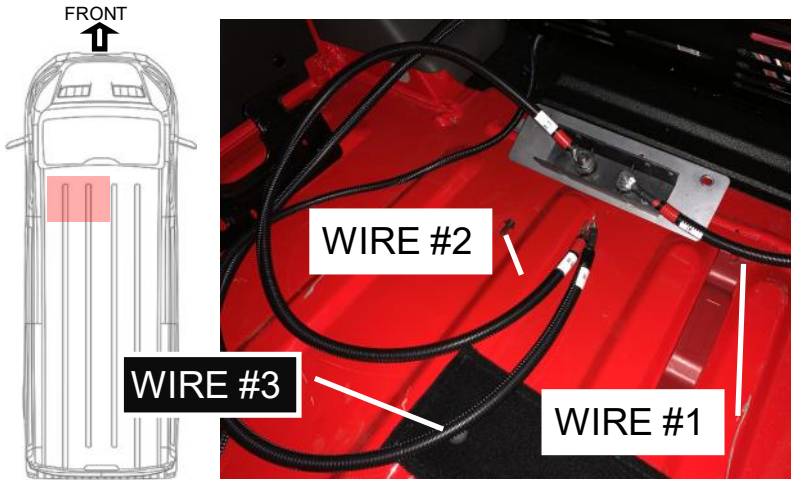

Caution: There will be no fuse installed at this point

- On the fuse holder that is already attached to **WIRE #1**, attach **WIRE #2** to the other fuse holder post and lightly tighten the fastener.
- Notice **WIRE #3** from the negative post is present in the photo.
- These two wires [**WIRE #2 & WIRE #3**] will be connected to the inverter terminals.

**Step 6A-17. Re-install Carpet Strip & Mount Fuse Holder**



- Replace the carpet strip into its position (Yellow Arrow).
- Flip it forward to expose holes for the steel battery hold down T-Bracket.
- Using the fasteners (Ref. NO.:14) that secure the T-Bracket over the battery, line up holes in fuse holder bracket with the T-Bracket and install the fuse holder on top of T-Bracket.
- The tightening torque for these 8mm/10mm fasteners is 10Nm [ $\pm$  1.5Nm] (89lb.in).
- Extra length of **WIRE#1** will push in beneath the battery cover and go into space beside battery as mentioned in Step 12.

## Section 6B: Two Chassis Battery (2CB) CABLE Routing [KITS 62835 & 60323]

### Step 6B-1. Observe Double Battery Orientation

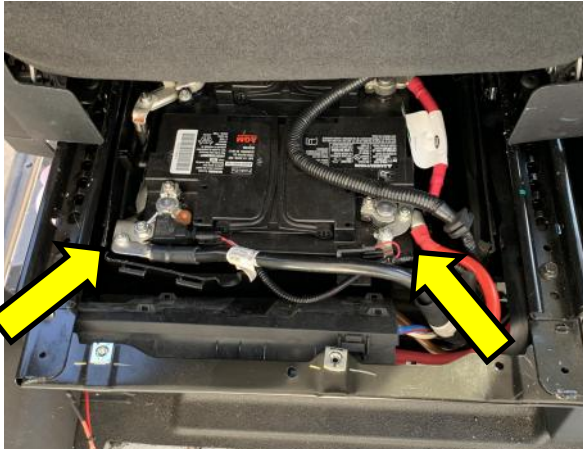
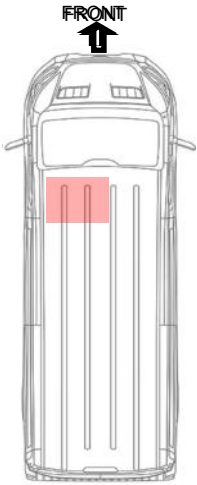

- In this configuration, the batteries are arranged so that both of the terminal on the battery Positive (+) and Negative (-) clamps are accessible from only behind the seat.
- Push seat fully forward and lift to highest position if possible.

### Step 6B-2. Identify Correct Lug Hole Diameters

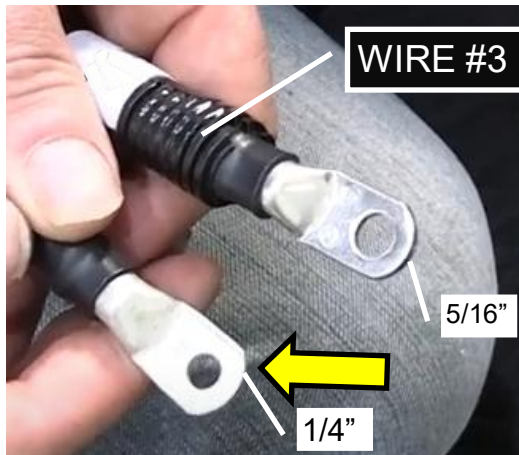

- Observe both lug ends of **WIRE #3**.
- One end has a 1/4" hole in the terminal, the other end has a 5/16" hole in the terminal.
- The 1/4" hole lug will be installed onto the terminal on the CB negative battery clamp.

### Step 6B-3. Install Wire #3 to the Negative Battery Post



- With the supplied (FAS0159 (Ref. NO.:7)) nut install **WIRE #3** [1/4" terminal] onto this smaller terminal.
- ① Torque the **WIRE #3** to 8Nm [ $\pm$  1.2Nm] (71lb.in) with 10mm socket.
- Tuck the other end of the **WIRE #3** out of the way. For safety it may be taped with electrical tape.

## Section 6B: Two Chassis Battery (2CB) CABLE Routing [KITS 62835 & 60323]

### Step 6B-4. Identify Correct Lug Hole Diameters

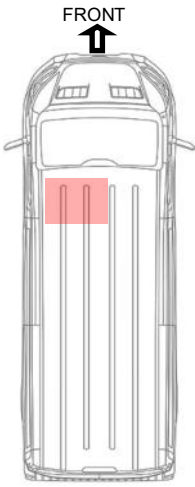

- The cabling kit that is used may have a shorter **WIRE #1**. This is because the positive battery post is closer to the MEGA Fuse mounting location.
- Observe the different sized holes.
- **WIRE #1** has 1/4" and 5/16" lug (similar to **WIRE #3**).

### Step 6B-5. Connect WIRE #1 to CB Fuse Holder



Caution: The fuse holder protects the end of the WIRE #1 from grounding



- Fasten down the fuse holder to the mounting plate [KEPS nuts (Ref. NO.:19) with nut with serrated washers. Use 3/8" nut driver and ensure they are snug.
- Connect the end of **WIRE #1** with the 5/16 hole to the empty fuse lug as shown (Terminal to the right).
- Temporarily, gently tighten 5/16 Fuse nut to hold cable onto stud. (Use 1/2" Nut driver).

### Step 6B-6. Locate and Loosen BMS Fuse Holder Fastener

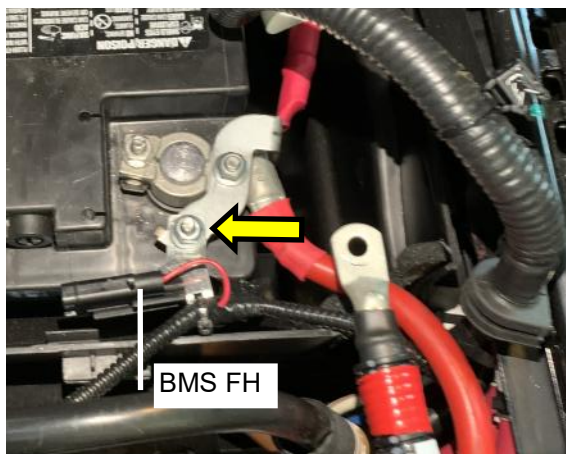

- Loosen nut [see Yellow Arrow] and remove *BMS* fuse holder (FH) fastener.

## Section 6B: Two Chassis Battery (2CB) CABLE Routing [KITS 62835 & 60323]

### Step 6B-7. Connection to Positive Terminal

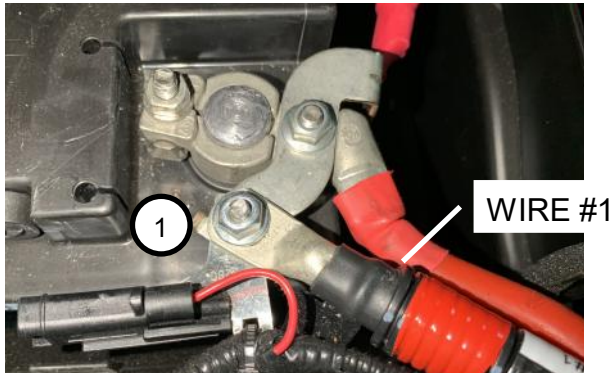
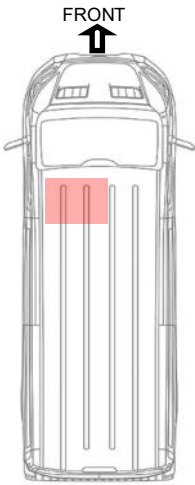

Caution: Use high caution or insulated wrenches when tightening on battery post!

- Use the supplied FAS0159 (Ref. NO.: 4) nut, connect **WIRE#1** and the *BMS* fuse holder to the terminal.
- ① Torque the **WIRE #1** and *BMS* fuse holder on the busbar to 8Nm [ $\pm$  1.2Nm] (71lb.in) with 10mm Socket.

### Step 6B-8. Cable Routing

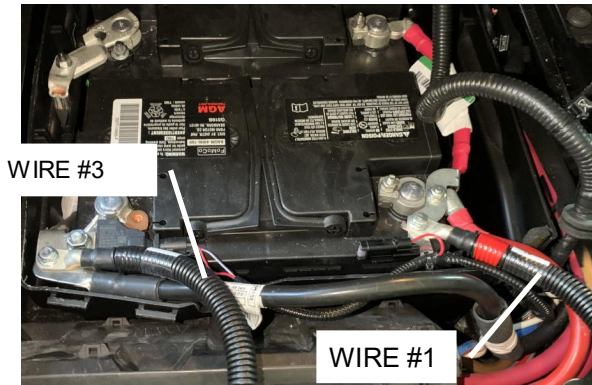

- Observe cable routing to prepare for notches to cut into battery cover.

### Step 6B-9. Neatly Route Extra WIRE #1

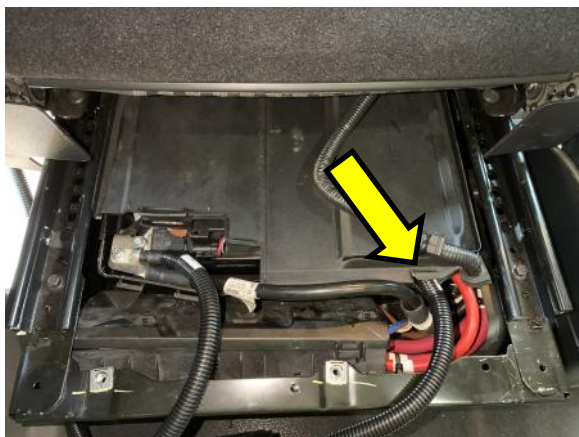

- Return the battery cover back over the batteries.
- Observe the notch cut for **WIRE #1** (Yellow Arrow).

## Section 6B: Two Chassis Battery (2CB) CABLE Routing [KITS 62835 & 60323]

### Step 6B-10. Connection to Positive Terminal

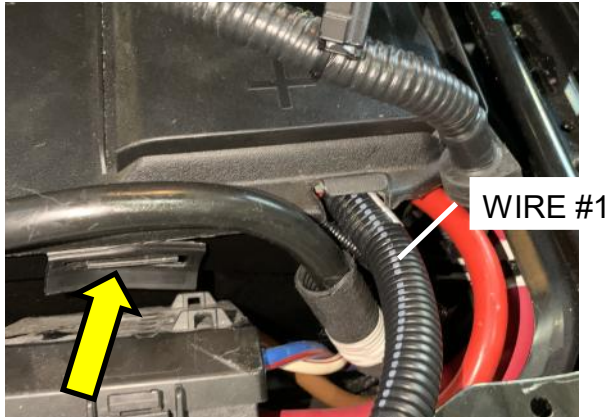
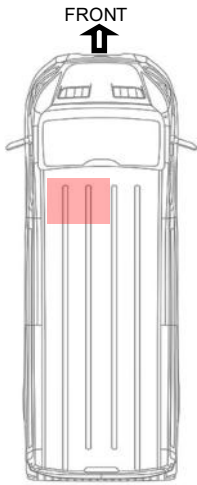

- Be sure battery cover can snap down over **WIRE #1** (At Yellow Arrow).

### Step 6B-11. Cable Routing for WIRE #3



- Observe **WIRE #3** cable routing to prepare for notches to cut into small battery cover.

### Step 6B-12. Adjust Small Negative Battery Terminal Cover



- In order to have the cover fasten back to larger battery cover, making a notch is necessary.
- The notch is cut using tin snips.
- The cover should be able to utilize existing snap on points to the larger cover.

## Section 6B: Two Chassis Battery (2CB) CABLE Routing [KITS 62835 & 60323]

### Step 6B-13. Re-installing the T-Bracket

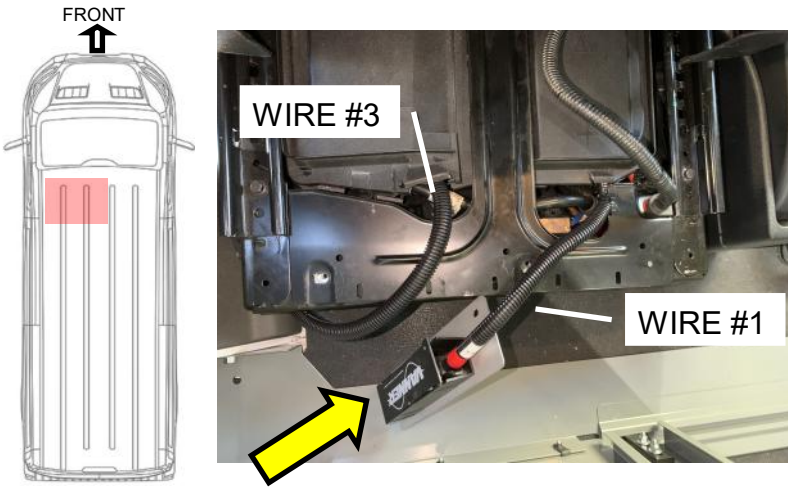

- Return the T-Bracket over the batteries and under **WIRE #1 & WIRE #3**.
- The MEGA fuse holder base plate (Yellow Arrow) will match with the two fastener holes for the T-Bracket.

### Step 6B-14. Re-installing MEGA Fuse Holder



Caution: There shall be no fuse installed at this point.

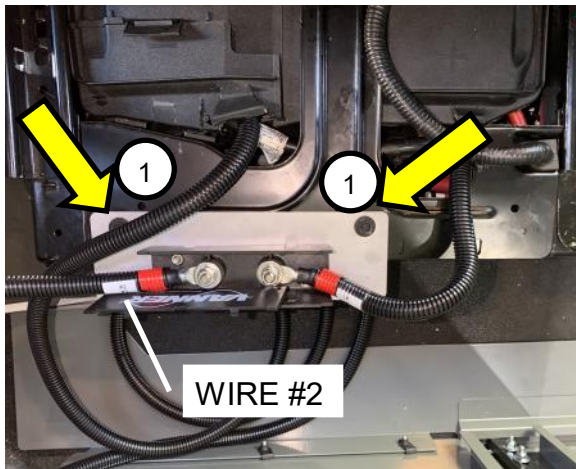

- Line up holes in fuse holder bracket with the T-Bracket and install the fuse holder on top of T-Bracket.
- ① The tightening torque for these 8mm fasteners (Ref. NO.:14) is 10Nm [+/- 1.5Nm] (89lb.in).
- Attach **WIRE #2** to the open post on the MEGA fuse holder. Hand tighten its 1/2" nut (Ref. NO.:8) .

### Step 6B-15. Re-installing Carpet Strip

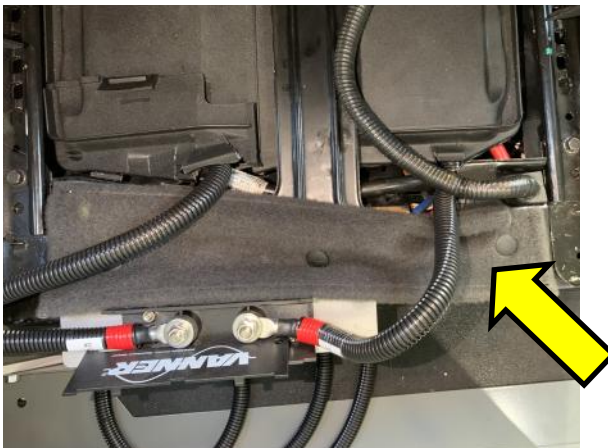

- Replace carpet strip if present [Yellow Arrow].
- At this point **WIRE #2** and **WIRE #3** will be ready to attach to the inverter.

## Section 7A: Vehicle Integration Locating the Remote Switch [KITS 68158, 66008 & 66006]

### Step 7A-1. Locating the Remote Switch

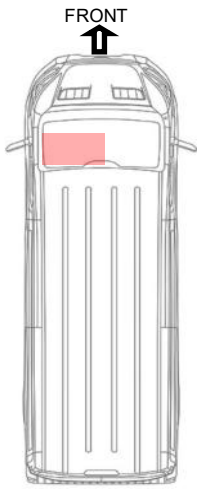

Be aware that there are supports and circuitry behind the panel.

- Slide seat *back* to access the area beneath the steering wheel.
- The recommended location of the Inverter remote switch is shown with a red dot on the knee bolster.
- Measurements shown in Step 7A-3 below.

### Step 7A-2. Locating Remote Switch



- Remove knee bolster beneath the steering wheel. It can be removed by pulling straight towards the driver seat. A plastic trim tool may aid in removal.
- Red dot is approximate placement of switch. A hole will be placed in this position.

### Step 7A-3. Measuring and Making Switch Hole

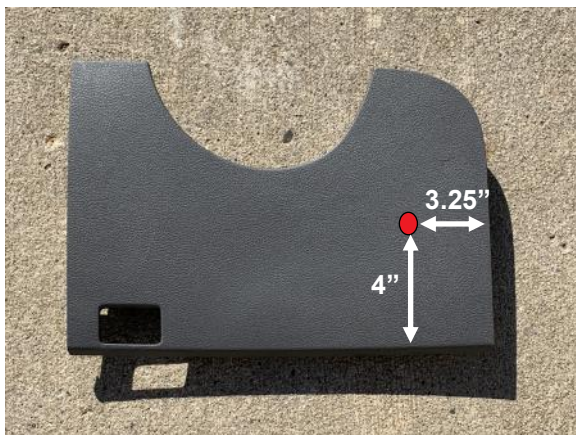

Be aware that there are supports and circuitry behind the panel— this hole and switch need to be located as to not interfere.

- The button location is 3.25" from the right side edge and 4" above the bottom edge of the knee bolster panel.
- A hole diameter of 3/4" [19mm] is necessary to install the snap in switch [do not insert switch yet].

**Section 7A: Vehicle Integration Remote Switch Harness Layout [KITS 68158, 66008 & 66006]**

**Step 7A-4. PRE-ASSEMBLED Timer Harness Layout**

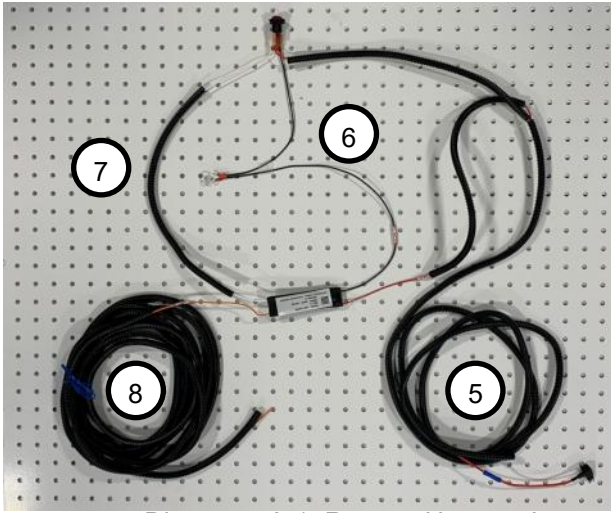

Diagram 7A-1: Remote Harness Layout



Be aware that the switch will not be connected until after the harness is installed and the knee panel is being installed.

- 5 ADD-A-FUSE WIRE to SWITCH and TIMER, “**WIRE #5**”- RED wire, Black Corrugate, HAAT
- 6 GROUND WIRE to SWITCH and TIMER, “**WIRE # 6**” - BLACK wire, Ground
- 7 REMOTE SWITCH to TIMER “**WIRE # 7**” - WHITE wire, Black Corrugate, Switch Signal
- 8 TIMER to INVERTER “**WIRE # 8**” - ORANGE wire, Black Corrugate, Remote Signal

**DIAGRAM 7A-5: The 66008 & 66006 Remote Switch Harness Diagram.**

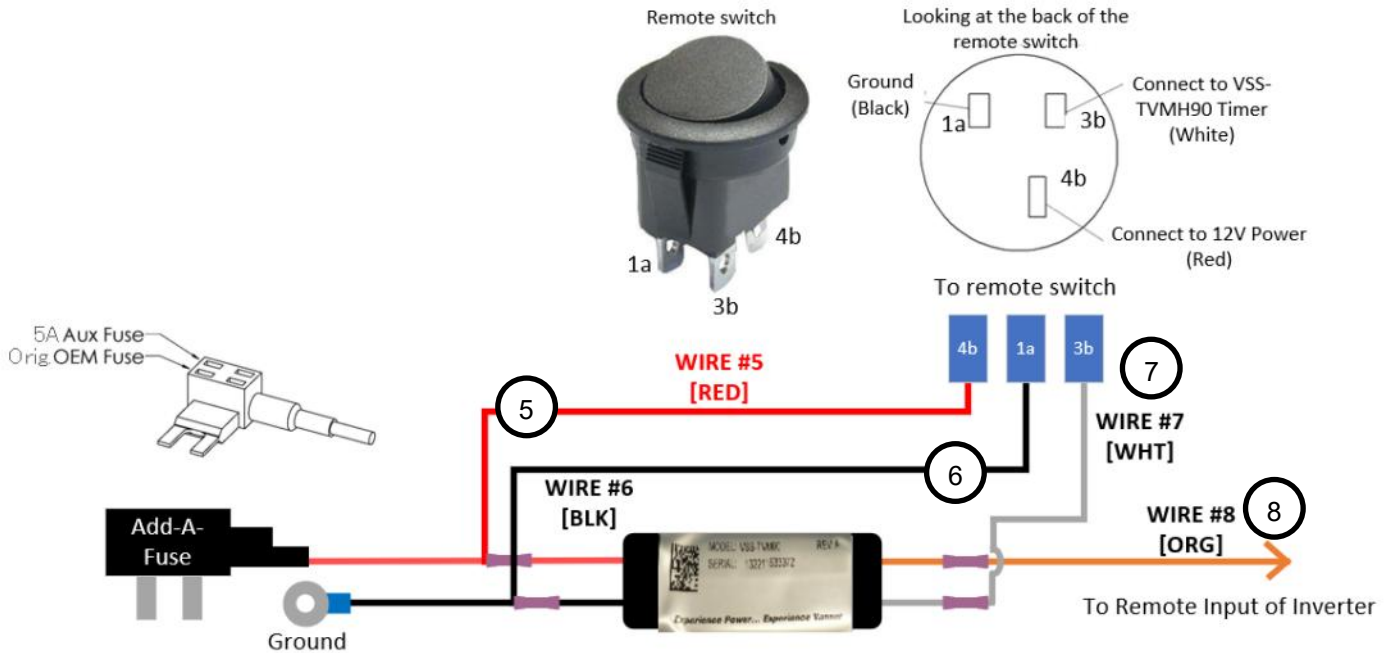
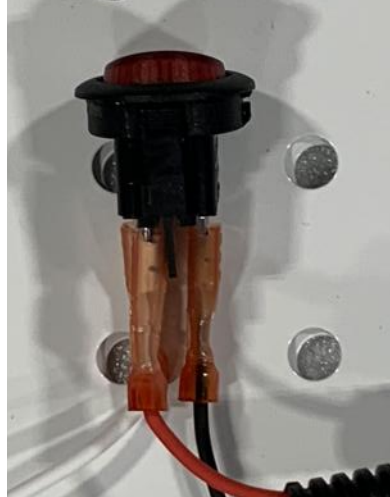
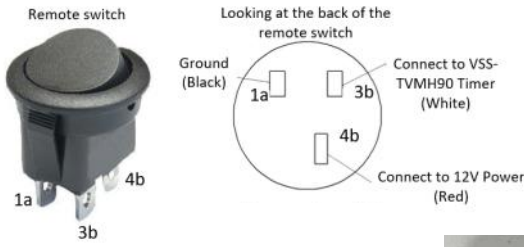

Diagram 7A-2: Remote Switch & Timer Harness Kit

- A diagram of the remote switch and timer harness assembly is shown in image above.
- It is pre-assembled excluding the switch, which is separate.
- The remote switch will be installed in the panel under the steering wheel as shown in Step 7A-2.
- The three spade connectors attached to color coded wire will be attached to the terminals of the switch after pulling them through the hole made in the knee bolster as shown above in Step 7A-3.

**Section 7A: Vehicle Integration Remote Switch Harness Layout [KITS 68158, 66008 & 66006]**

**Step 7A-6. Preparation to Connect Remote Switch**



- The crimped on spade terminals of **WIRES #5, #6, and #7** will be pushed firmly onto the stakes of the provided switch (according to Diagram 7A-2 ) **af-ter** being pulled through the switch hole drilled earlier in the knee bolster.

Diagram 7A-3: KIT 66008 & 66006 Remote Switch Connections

**Section 7A: Vehicle Integration Switch Installation [KITS 68158, 66008 & 66006]**

**Step 7A-7. Remove Fuse (F-76: 10A [Red])**

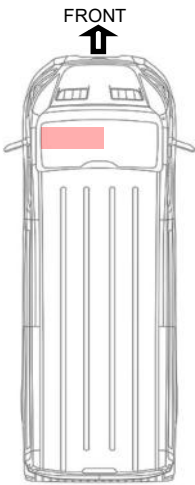

**For Model Year 2026+ Fuse Panel Add-a-Fuse Location, see next page**

- Find F-76 according to the fuse block diagram in Section 5, **Figures 5-3/5-4**.
- Remove the fuse.

**Step 7A-8. Insert Fuses into Add-A-Fuse**



- Remove Fuse #76's Fuse and put it into the Add-A-Fuse holder as shown [10A Red].
- The 5A AUX Fuse piggyback fuse is for the inverter's remote switch.

**Step 7A-9. Insert the Add-A-Fuse into Panel**



- The Add-A-Fuse will be pushed into the space of Fuse #76.
- The other side of the wire is a covered terminal for prevention of shorting to ground.
- That terminal will be connected to the timer/switch or switch depending on KIT.

## Model Year 2026+ Fuse Panel Add-a-Fuse Location

Note: New Fuse Box shape for 2026 and beyond. Same fuse locations with or without 67C.

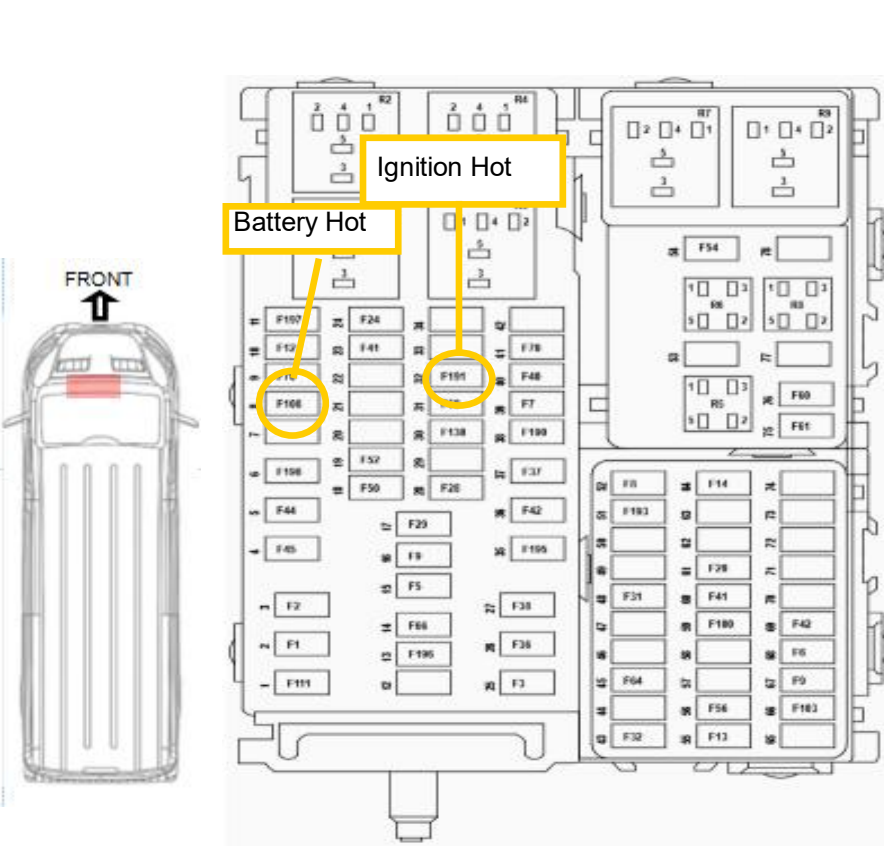

Without 67C

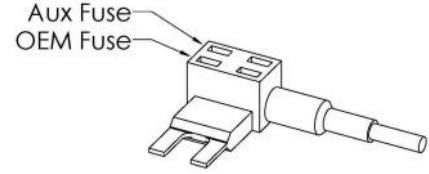

- The Fuse Panel is located behind the knee bolster and can be accessed after bolster removal step.
- Position 32 F191 is 10A Ignition hot.
- Position 8 F108 is Battery hot.

With 67C

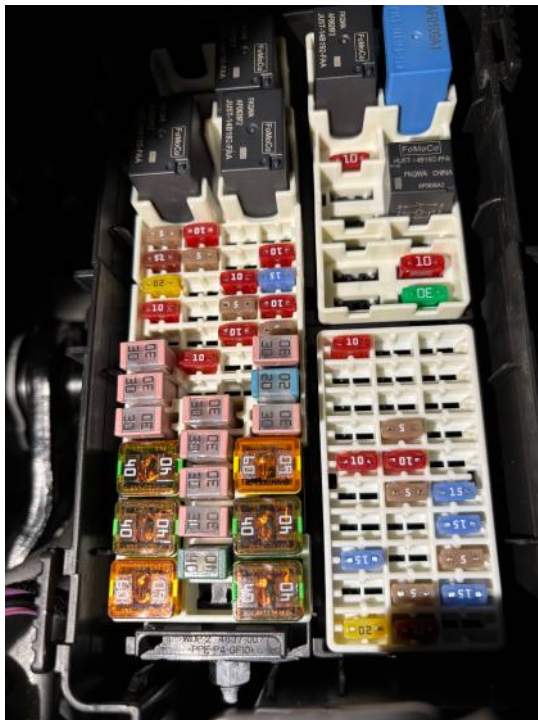

## Section 7A: Vehicle Integration Switch Installation [KITS 68158, 66008 & 66006]

### Step 7A-10. Switch or Switch/Timer Fitment in Dash Cavity

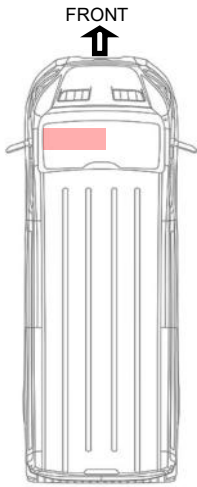

- With the Add-A-Fuse installed, the switch/timer harnessing may be brought into the area where the knee bolster would be installed for fitment.
- The harnessing should be tucked into the cavity out of the way of any moving parts and near a surface that it can be wire-tied appropriately.

### Step 7A-11. Ground Ring Terminal with Self-tapping Screw

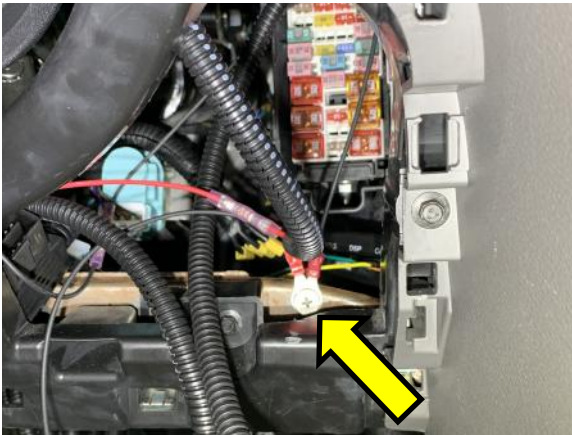

- The ground ring terminal on ground **WIRE #6** is fastened to the steel sub-structure using a self-tapping screw (Tek screw Ref. NO.:11).
- Location chosen here (Yellow Arrow) allows easy fastening.

### Step 7A-12. Remote Wire Routing

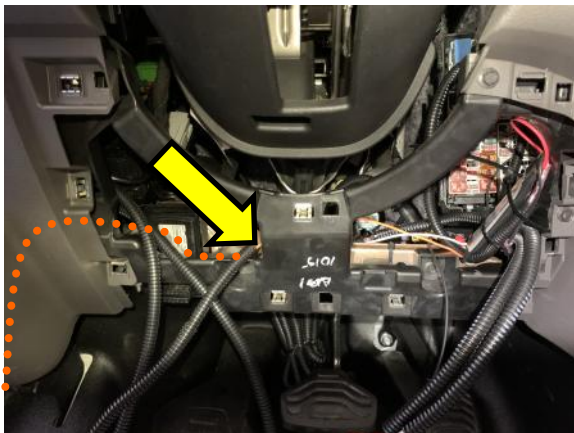

- The long Orange **WIRE #8** remote wire will be fed behind and across the area under the steering wheel— behind the knee bolster support structure.
- This wire loom is routed to the street side and brought down through the inside door trim where it can be pulled through. Following path of orange dotted line.
- Avoid any steering linkage area.

**Section 7A: Vehicle Integration Switch Installation [KITS 68158, 66008 & 66006]**

**Step 7A-13. Anchoring the Timer and Harness**



Be aware that here are supports and circuitry behind the panel.



- Use nearby holes to wire tie fasten the timer to the inside of the dash where it will not interfere with the reinstallation of the knee bolster panel.
- Note the switch spade terminal wires [Yellow Arrow] may need to be adjusted after they are pulled through the 3/4" hole just before panel is reinstalled [see below].

**Step 7A-14. Connect the Remote Switch**

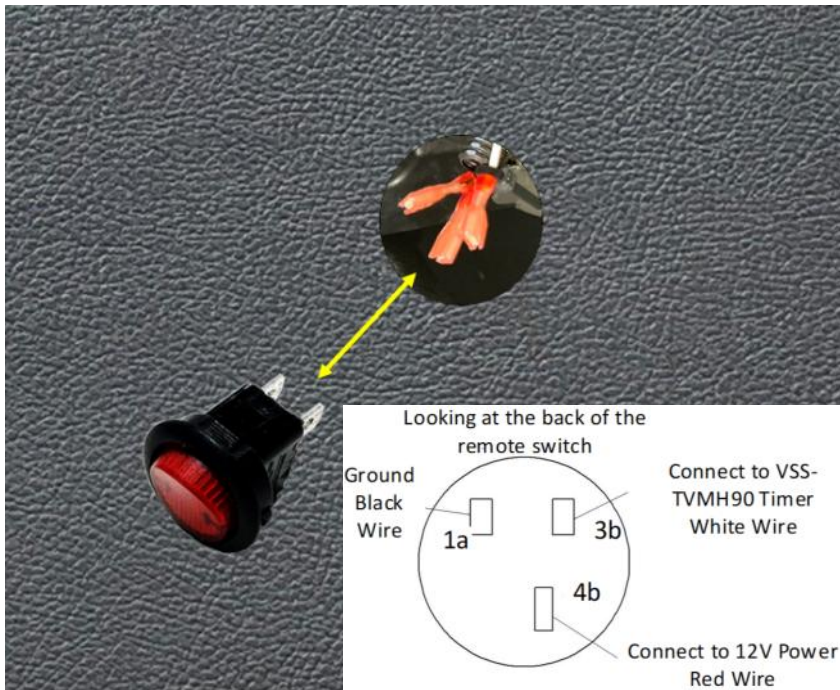

- Pull the three switch spade terminal wires through the knee bolster hole and connect according to wire color and stake label [1a (Black), 3b (White), 4b (Red)].
- Install the knee bolster after Orange WIRE #8 is routed.

**Section 7A: Vehicle Interface For Non-67C Application [KITS 68158, 66008 & 66006]**

**Step 7A-15. Remote Wire Routing**

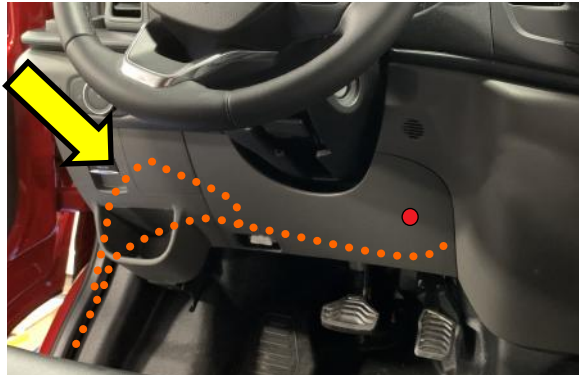
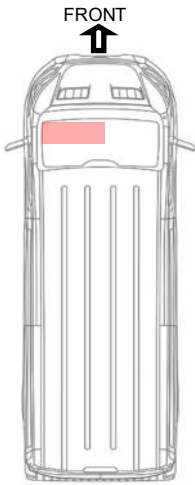

- When finished, the Orange **WIRE #8** will follow a path similar to either of the orange dotted lines shown here.

**Step 7A-16. Planning Routing for Orange**



Caution: Be aware of steering shaft and any other mechanism-follow other wire routing.

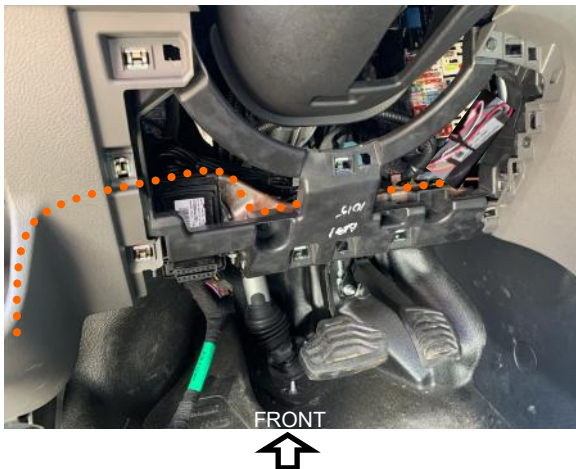

- The Orange **WIRE #8** will route beneath the steering wheel inside the area behind the knee bolster. Be sure it lay flattened and cannot be caught up in the steering linkage. Use wire ties to anchor it down.
- It may be routed behind the dash down through the driver's door frame trim.

**Step 7A-17. Route Planning for Orange Remote Wire**



- When reaching the end of the dash panel, the loom may be routed down through a channel to the door trim.

OR

- Routed down near the cup holder and then tucked up and to the side under the edge of the dash panel nearest to the door.

## Section 7A: Vehicle Integration Remote Wiring Routing [KITS 68158, 66008 & 66006]

### Step 7A-18. Routing of Remote Wire

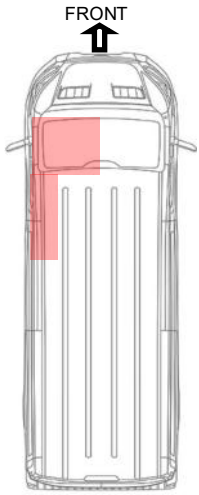

- As shown in Step 7A-17, the Orange **WIRE #8** loom will be hidden under this doorway trim.



### Step 7A-19. Moving Trim to Fit Wire Loom

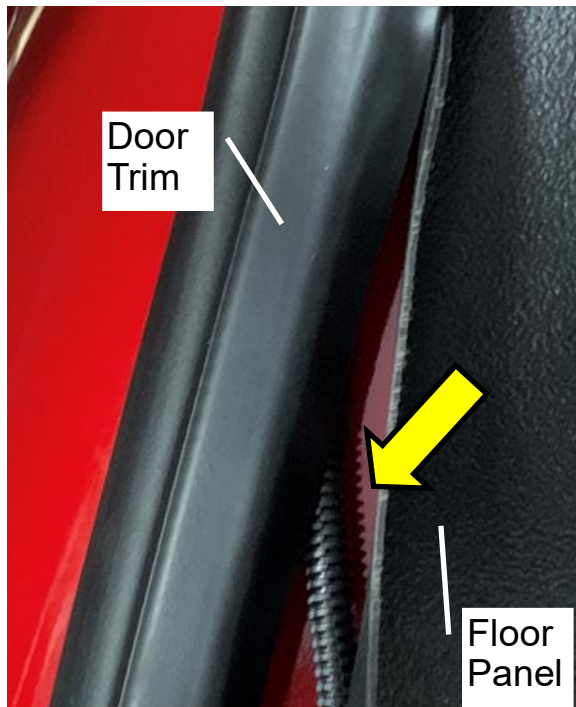

- After it has been pulled through from behind the dash board after the installation of the timer, the remote wire loom [corrugate shield] will compress and be hidden under the door trim.
- The floor panel should be returned in its position under the edge of the trim after loom is pressed beneath door trim.

## Section 7A: Vehicle Integration Remote Wiring Routing [KITS 68158, 66008 & 66006]

### Step 7A-20. Routing of Remote Wire beneath Door Threshold

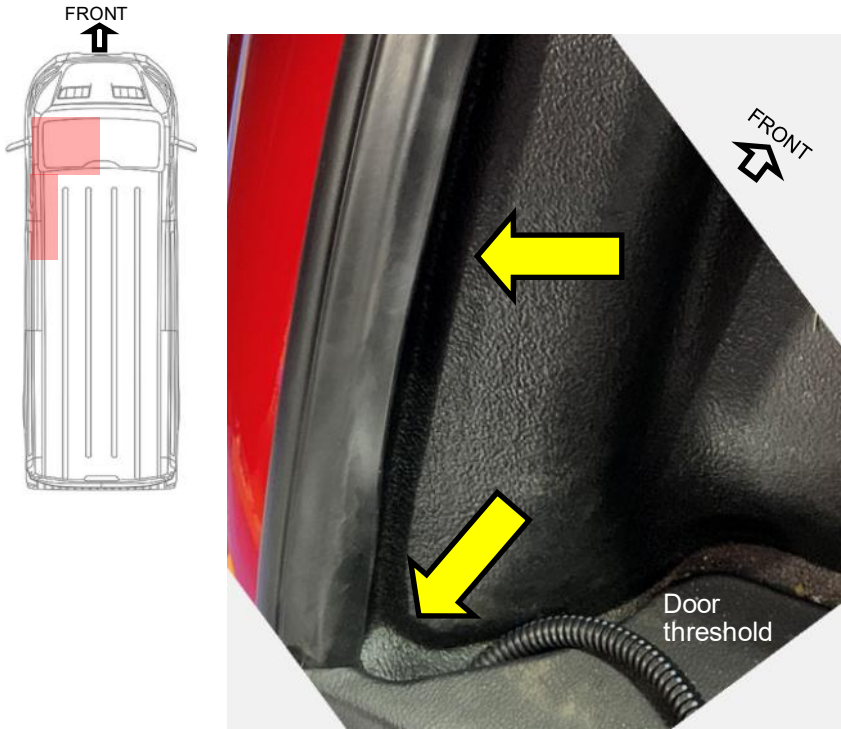

- The floor panel is replaced and the routing of the loom continues under the door threshold.

### Step 7A-21. Installation Under the Door Threshold

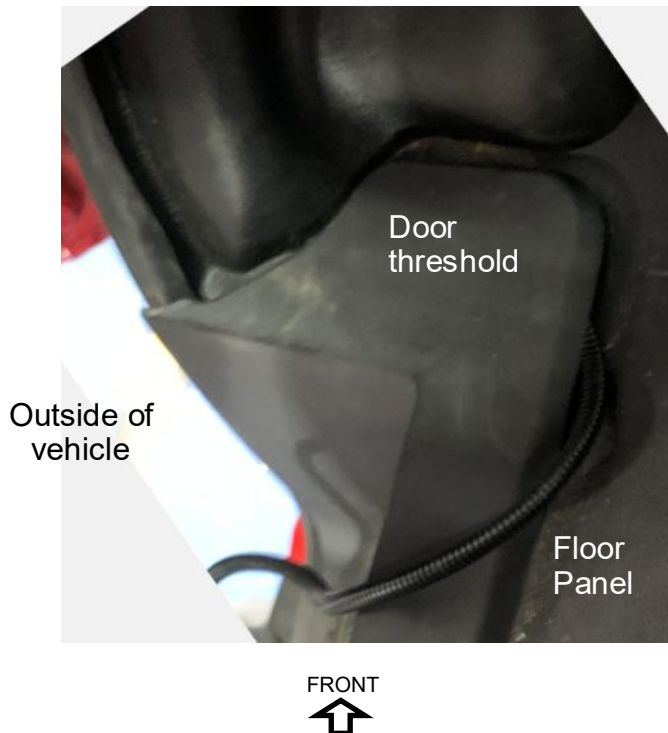

- The remote loom continues along under the edge of the door threshold toward the driver seat base.

## Section 7A: Vehicle Integration Remote Wiring Routing [KITS 68158, 66008 & 66006]

### Step 7A-22. Routing of Remote Wire Towards Seat

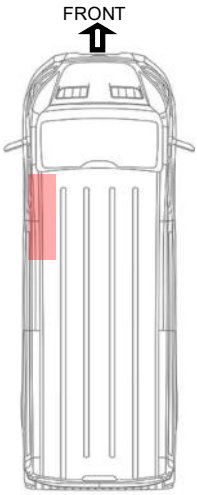

- Routing of the loom continues under the door threshold until it reaches the driver seat base.

### Step 7A-23. Installation under Seat Base Flange



- A plastic trim tool is used to assist and to push the remote wire into space beneath the edge of the driver seat base.

## Section 7A: Vehicle Integration Remote Wiring Routing [KITS 68158, 66008 & 66006]

### Step 7A-24. Routing of Remote Wire along Seat Flange

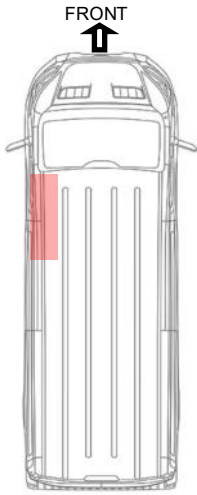

- The wire then goes along the street side edge of the driver seat base.
- Stuff it beneath the seat base flange to secure and hide the wire/corrugated loom.

---

### Step 7A-25. Remote Wire Routing behind Driver Seat

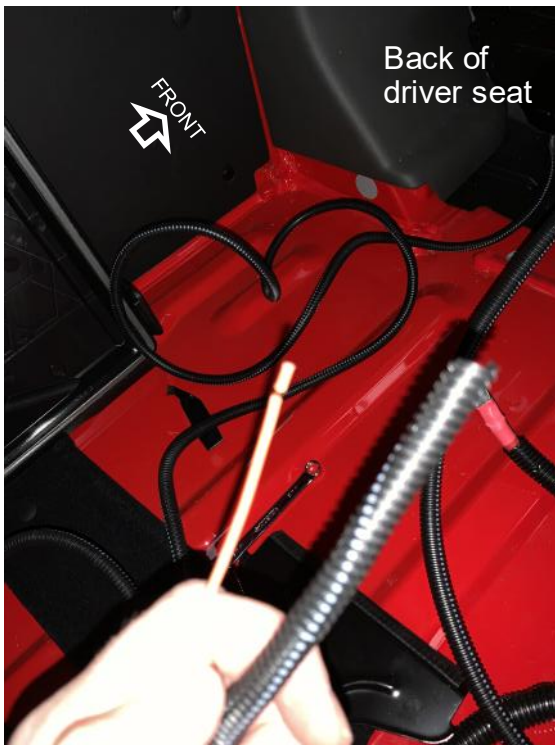
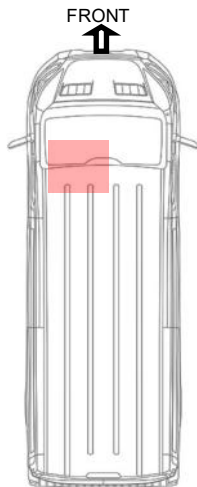

- The remote wire loom exits the back of the seat base and will have extra length.
- This will be trimmed at a later step.
- Two Cables and one Orange wire will be ready for following connections.

## Section 7B: Vehicle Interface For 67C Application [KITS 62835 & 60323]

### Step 7B-1. Accessing the 43-way Connector Behind Glovebox

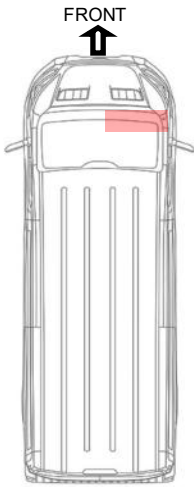

- The Ford Transit with the 67C option package utilizes some of the existing electrical circuitry in the vehicle.
- It is behind the glove box access door.
- The passenger door will need to be opened.

### Step 7B-2. Glovebox Removal



- Empty the glove box.
- There are release latches/stops on both sides of the glovebox back surface (see arrows).
- Press these stops inward to release the glove box so that it drops toward the floor.

### Step 7B-3. Access Door Removal



- There is another access door that can be removed in the cup holder by the passenger knee bolster.
- This can be pulled out by the top handle and rotated downward and out.

## Section 7B: Vehicle Interface For 67C Application [KITS 62835 & 60323]

### Step 7B-4. 67C Remote Wire Route planning

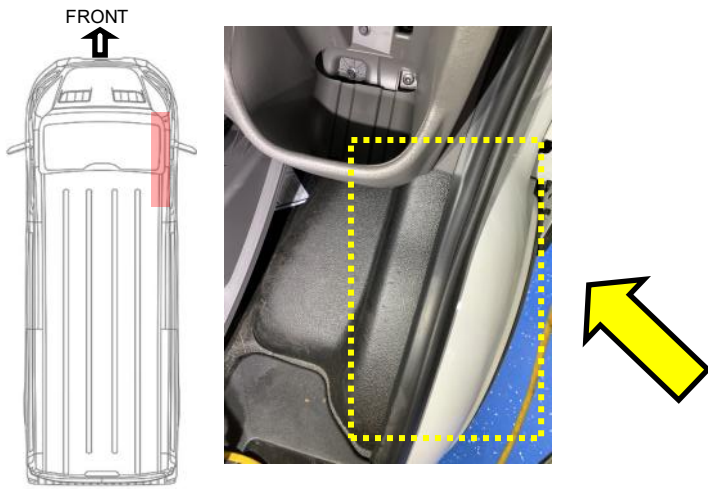

- The **WIRE #5** orange remote wire loom will be hidden under this doorway trim.
- But first it must be pushed up into the cavity behind the dashboard. Alternately – it may be brought down from behind the glove box and tucked behind the knee panel and then doorway trim.

### Step 7B-5. 67C Remote Wire Route planning

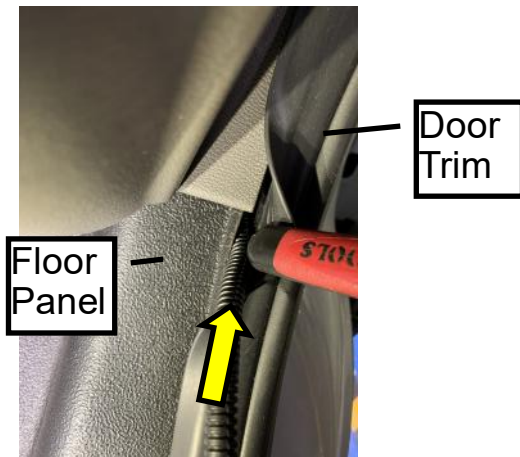

- Pull away the door trim and floor panel enough to be able to push the wire loom upward and behind the dashboard.
- The corrugate loom should be able to be pushed up about 16”.

### Step 7B-6. 67C Remote Wire Route

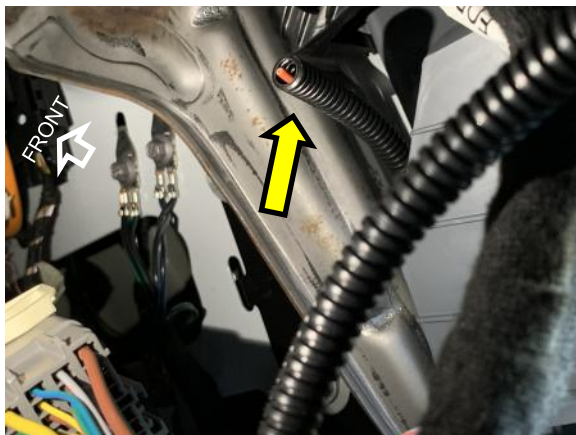

- Using the push up from below method, looking in through the glove box port [to the right], towards the curbside fender sheet metal, the **WIRE #5** orange wire corrugate can be seen.
- Pull the wire and corrugate while feeding in another ~18”.
- The **WIRE #5** Orange Remote wire may also be routed in through the glovebox and wedged into place under the glovebox trim if preferred.

## Section 7B: Vehicle Interface For 67C Application [KITS 62835 & 60323]

### Step 7B-7. Connecting to 43-Way Upfitter Connector



- The **WIRE #5** corrugate Orange wire loom is shown here pulled out and ready for next step.

### Step 7B-8. Strip Orange wire



- The end to the **WIRE #5** Orange wire will need to be stripped so that it can be joined to the wire in the 67C Upfitter's connector.

### Step 7B-9. Identifying AUX 1 Switch wire on connector



- The upfitter connector will be delivered with the vehicle. It may be in the glove box in a bag.
- This 43 way connector is called the "High Specification Vehicle Interface"

## Section 7B: Vehicle Interface For 67C Application [KITS 62835 & 60323]

### Step 7B-10. Identifying AUX 1 Switch wire on connector

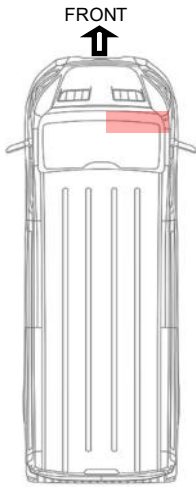

**High Specification Vehicle Interface Connector**

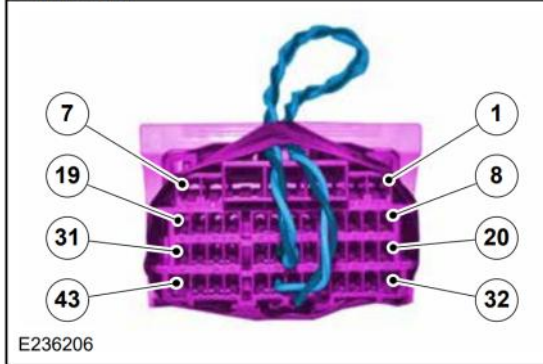

- This is a photo of the blank connector for illustration purposes.
- Pin 1 is the Switched Upfitter Output #1.
- Locate Pin 1 on the connector itself to verify wire color
- This wire should be a larger **16AWG GREEN** wire in the harness.

### Step 7B-11. Strip the AUX 1 Green Wire

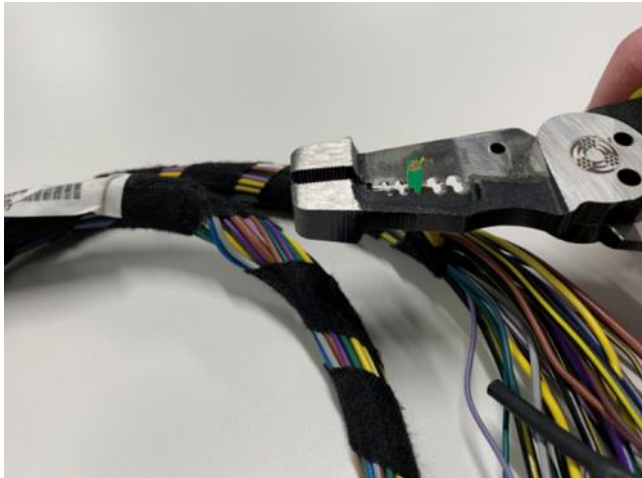

- This **16AWG GREEN** wire will be stripped so that it may be butt spliced to the **WIRE #5 Orange** remote wire.

### Step 7B-12. Connecting Green and Orange wires

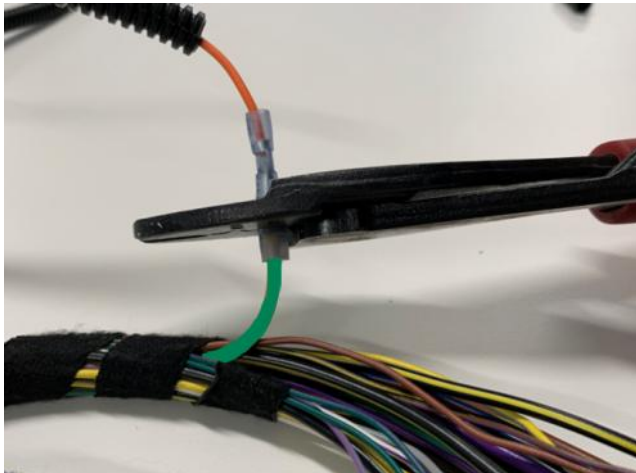

- Insert the **WIRE #5 Orange** wire into butt splice crimp already on the Green 67C connector wire and crimp firmly.

## Section 7B: Vehicle Interface For 67C Application [KITS 62835 & 60323]

### Step 7B-13. Sealing joint between Green and Orange wires

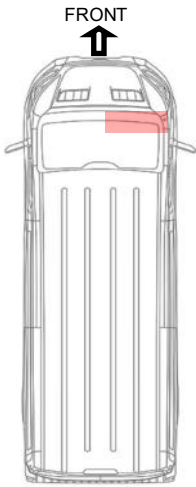

- The crimp insulation can be shrunk if heat gun is available.

### Step 7B-14. Upfitter Connector Preparation



- Remove blank High Specification Vehicle Interface connector and place in safe location for future use if necessary.

### Step 7B-15. Upfitter Connector Preparation



- The remaining side of the harness will accept the prepared upfitter connector and its harness.

## Section 7B: Vehicle Interface For 67C Application [KITS 62835 & 60323]

### Step 7B-16. Upfitter Connector Connection

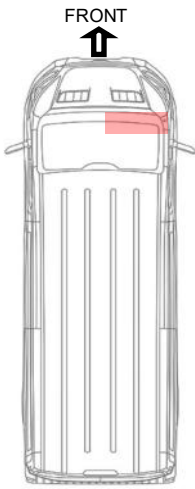

- Plug in the harness and make sure the lock is rotated and snapped in place to ensure the connectors are fully seated into each other.

### Step 7B-17. Change Auxiliary Fuse Position

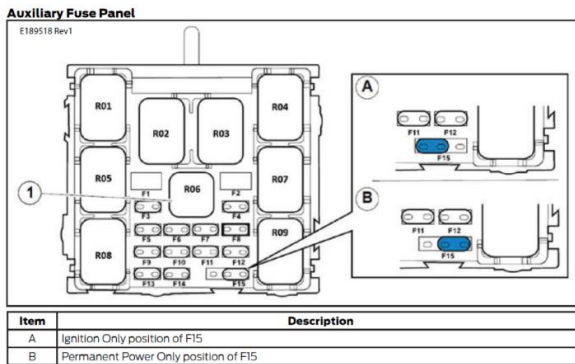

- NOTE: AT THIS POINT REFER TO FIGURE 5-5: OPTION 67C AUXILIARY FUSE PANEL—BE SURE THE FUSE IS IN POSITION “B”.

### Step 7B-18. Completed Upfitter Connector Stowage

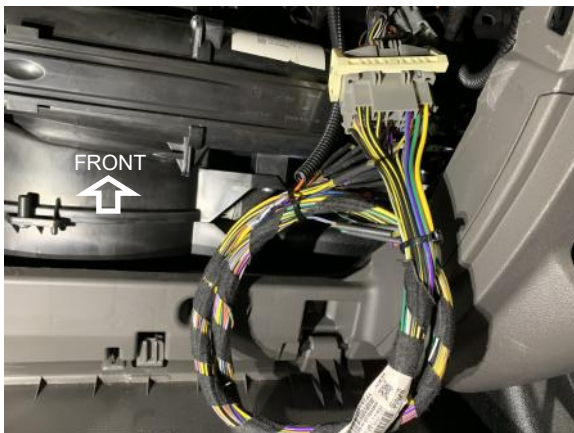

- Use Ty wraps to neatly bundle the harness to stow out of the way behind the cupholder area.

## Section 7B: Vehicle Interface For 67C Application [KITS 62835 & 60323]

### Step 7B-19. Completed Upfitter Connector Stowage

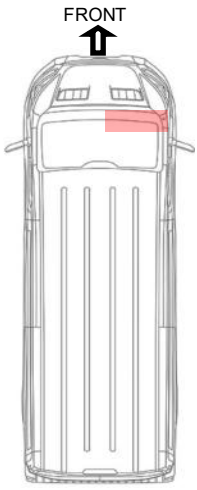

- The harness can be ty wrapped onto any solid point.
- Be sure it will not interfere with the glove box when it is installed.

### Step 7B-20. Re-Installation of Glove Box



- Install the glove box and cup holder access panel.

### Step 7B-21. Routing of the Orange Remote wire

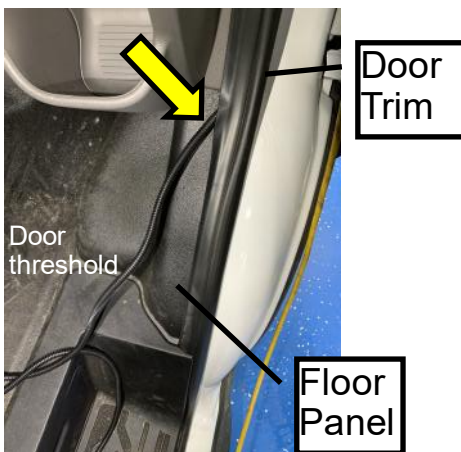
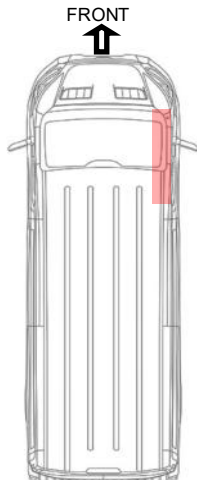

- The **WIRE #5** orange remote wire loom [corrugate shield] will compress under the door trim.
- The floor panel should be returned in its position under the edge of the trim after the loom is pushed in.

## Section 7B: Vehicle Interface For 67C Application [KITS 62835 & 60323]

### Step 7B-22. Routing of the Orange Remote wire

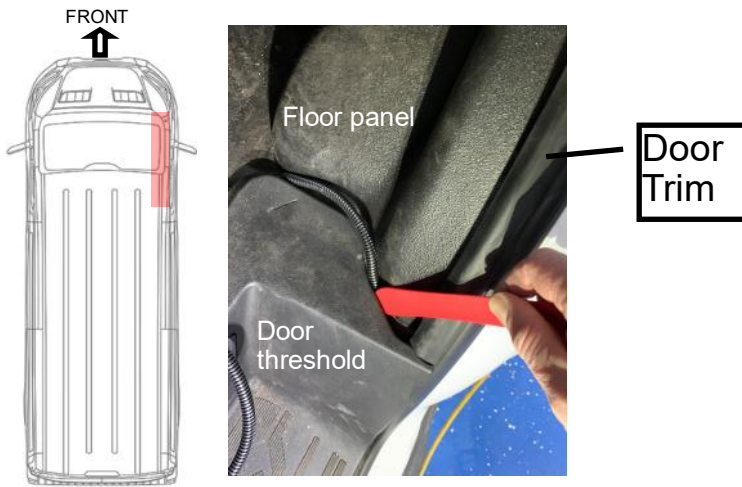

- Use the plastic trim tool to carefully guide the **WIRE #5** Orange wire loom underneath the door threshold trim.

### Step 7B-23. Routing of the Orange Remote wire beneath threshold



- The loom will continue to be pushed beneath the door threshold trim until it meets the bottom flange of the passenger seat base.

### Step 7B-24. Routing of the Orange Remote wire beneath seat mount



- A plastic trim tool is used to assist and to push the remote wire into space beneath the edge of the drivers seat base.
- The wire then goes along the curb side edge of the passengers seat base.
- Stuff it beneath the seat base flange to secure and hide the wire/corrugated loom.

## Section 7B: Vehicle Interface For 67C Application [KITS 62835 & 60323]

### Step 7B-25. Routing of the Orange Remote wire behind seat mount

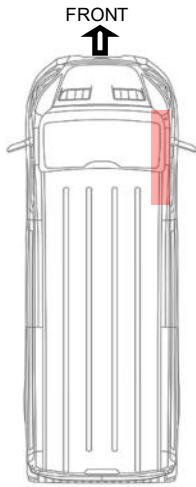

- When the **WIRE #5** orange wire loom reaches the end of the seat flange, it can then continue behind the seat.
- The **WIRE #5** orange wire can be tucked underneath the floor covering in any manner to keep it shielded from any damage.

### Step 7B-26. Routing of the Orange Remote wire behind seating

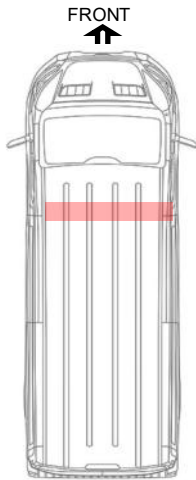

- The **WIRE #5** orange wire can also be continued to be tucked beneath the passenger's seat base flange.

### Step 7B-27. Routing of the Orange Remote wire to the Inverter area



- The **WIRE #5** orange wire loom will be routed to the area behind the driver's seat to meet the inverter when it is installed.
- **WIRE #2** and **WIRE #3** will also be waiting here to be connected to the inverter.

## Section 8: Inverter Installation: Wire and Cabling

### Step 8-1. 400, 700W & 1000W Inverter Preparation



The inverter's screw terminals are difficult to pull out of the Red and Black terminal guards.

- Before mounting inverter to the partition, there will likely be limited space to connect the wiring. It is advised that the connections are made before installation, depending on the access.
- Loosen the #3 Phillips (+) fasteners on terminals and remove them for the moment.

### Step 8-2. Installation of Cables into Inverter

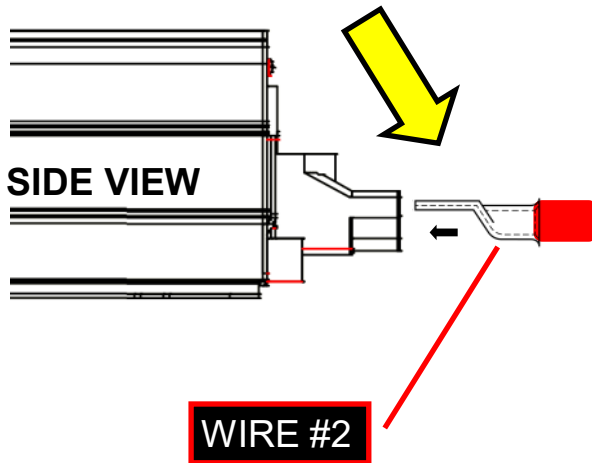

The lugs should fit squarely into the terminal covers and sit flat upon the terminal surface. They may need to be turned over.

- Recall **WIRE #2** and **WIRE #3** and their open terminals behind the driver seat [Steps 6A-16 & 6B-15].
- Bring the wires neatly to the terminals on the inverter.
- Be sure to orient the cable lug so that it fits squarely into the inverter terminal (flat side up).

### Step 8-3. Installation of Cables into Inverter



Caution: All DC connections should be tightened to proper torque to avoid loosening during time in service.

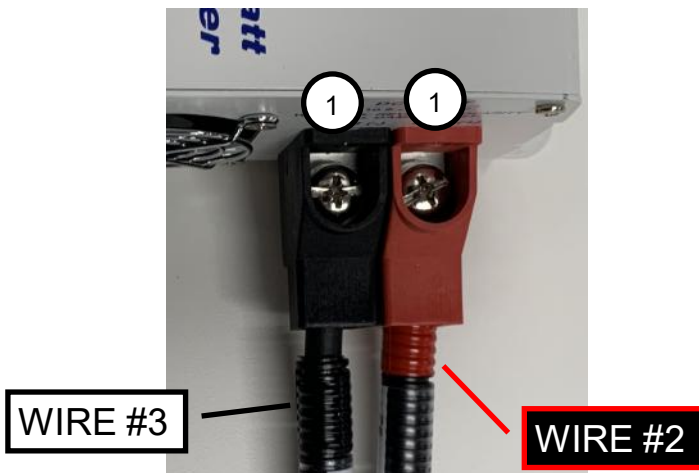

- 1 These connections shall be torqued to 12.4Nm [+/- 0.7Nm] (110 lb.in).

- Use wire ties to keep the wires from moving apart.

## Section 8: Inverter Installation: Wire and Cabling

### Step 8-4. Inverter Chassis Ground Installation



Caution: All DC connections should be tightened to proper torque to avoid loosening during time in service.

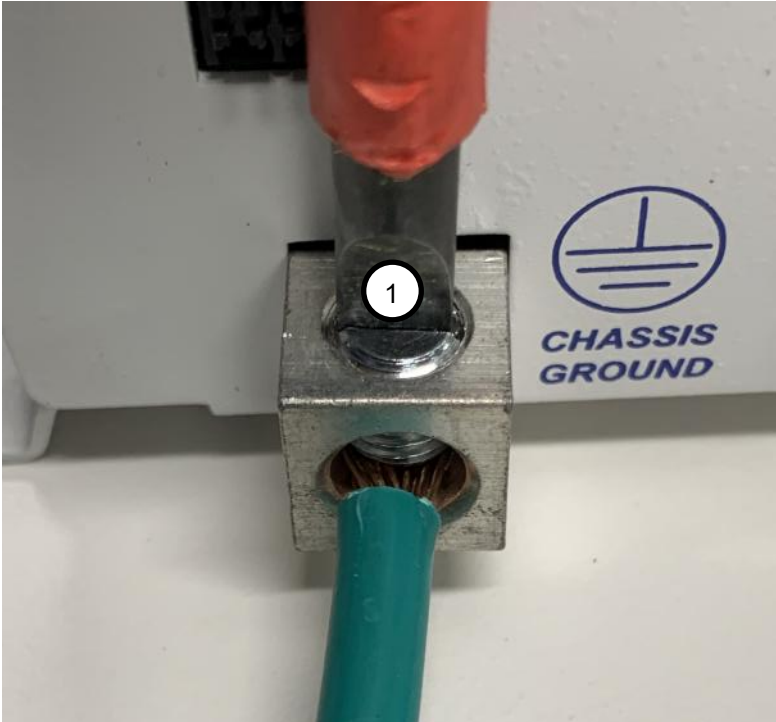

- The 8AWG GREEN Inverter ground **WIRE #4** has an end with the insulation pre-cut
- Remove the insulation and clamp into the Chassis Ground terminal.

1

This connection shall be torqued to 12.4Nm [+/- 0.7Nm] (110 lb.in).

### Step 8-5. Remote Wire Connection to Inverter



- The remote Orange WIRE #8 (from **Step 7A-25**) or **#5** (from **Step 7B-27**) installed earlier is length adjusted so there is not excessive extra length. It can also be coiled and fastened with wire tie.
- The Orange WIRE #5 or #8 is stripped about 3/8", twisted to avoid strays, and pushed into the #1 terminal in the black remote control header.
- If it must be released for any reason, push the square button above the terminal hole *and hold* to disengage the spring clamp, then pull the wire out.

## Section 8: Inverter Installation: Settings

### Step 8-6. Inverter Front Face

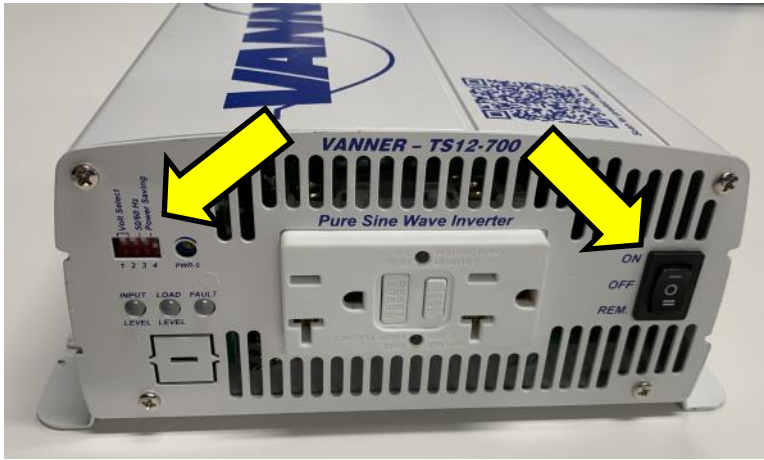

- This side of the inverter will face the center of the vehicle.
- On the front side of the inverter, insure the setting switches are correct...

### Step 8-7. Function Switches

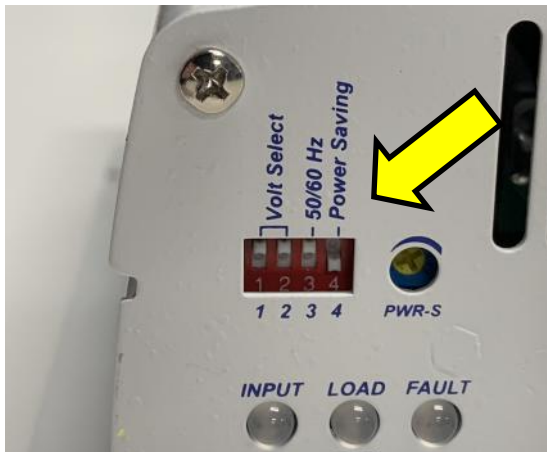

- The inverter function switches should be set to:
- 1-UP/2-UP/3-UP/4-Down [120V, 60Hz, with power saving OFF].

### Step 8-8. Remote Switch Confirmation

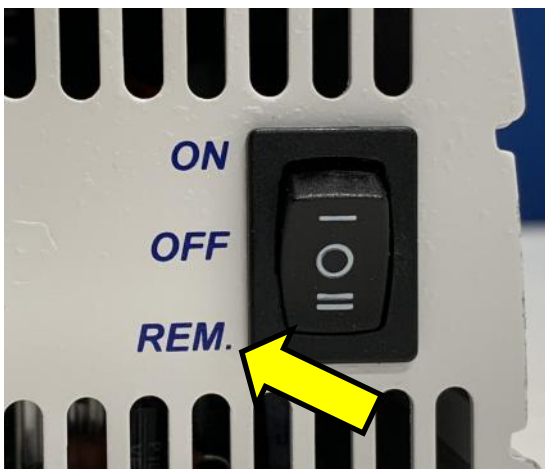

- The Inverter switch must be switched to "REM." (remote) to avoid inadvertent discharge of the battery(ies).

## Section 8: Inverter Installation: Partition/Bracket Mounting

### Step 8-9. Inverter Installation to Partition

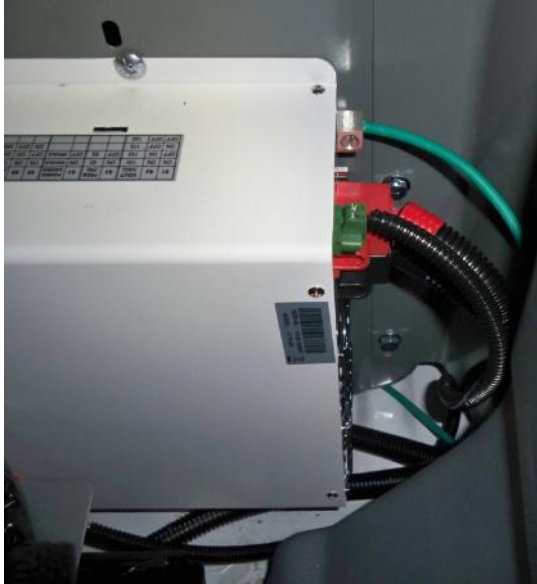
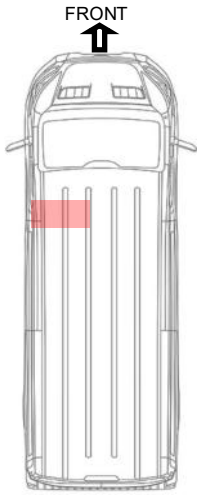

- Install the inverter horizontally in the pre-drilled holes in the partition (There may be several hole positions for different sized inverters) OR mount to the appropriate holes in the Composite Partition Accessory Mounting Kit (sold separately).
- Use FAS0055 and FAS0018 to mount the inverter to the partition itself or rails provided on the partition.
- The recommended tightening torque for these fasteners is 12Nm [ $\pm$  1.8Nm] (106lb.in) with a 7/16" socket.



### Step 8-10. Inverter Ground Wire



- The other end green inverter ground **WIRE #4** will have a ring terminal that must be fastened to a local chassis ground.
- The partition hold down fastener near the inverter holding the partition to the floor is recommended.
- Utilize torque specification found for that fastener in the partition installation kit.

## Section 9: Fuse Installation

### Step 9-2. Fuse Size Reference

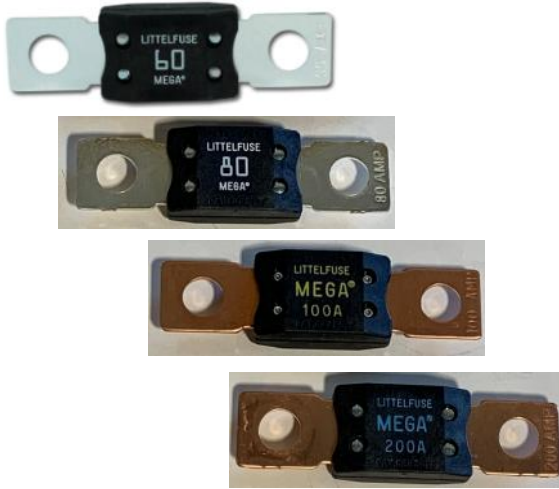
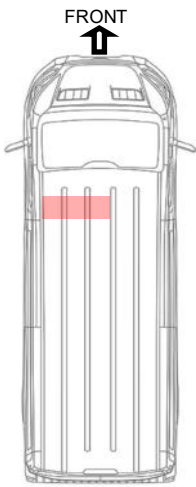

- For Reference, the fuses sized to each kit are here.
- Do not use a fuse exceeding the rating of the system.
- KIT 68158: 60A
- KIT 66008: 80A
- KIT 62835: 100A
- KIT 66006: 200A
- KIT 60323: 200A

### Step 9-2. Insert MEGA Fuse into VANNER Fuse Holder



Caution: The WIRE #1 is a live wire. It needs to be controlled while adding fuse.



- Make Sure Red Rocker Switch is in off position.
- Carefully unscrew and remove the nuts/washers from the fuse terminals while holding the **WIRE #1** and **WIRE #2** down on the posts.
- Place the KIT fuse across the terminals (*There may be a small spark during this procedure*) and fasten the nut on **WIRE #1 first**.
- Fasten the other nut onto the **WIRE #2** terminal.

### Step 9-3. Close Fuse Holder



Caution: During torquing be aware of touching other grounded metal parts!



- 1 Both fuse fasteners should be torqued to 12Nm (106lb-in) with 1/2" socket.
- Replace the safety cover onto the fuse holder and assure that it snaps in place

## Section 10: Important Labeling

### Step 10-1. Apply Remote Inverter Switch Label (KITS 68158, 66008 & 66006)

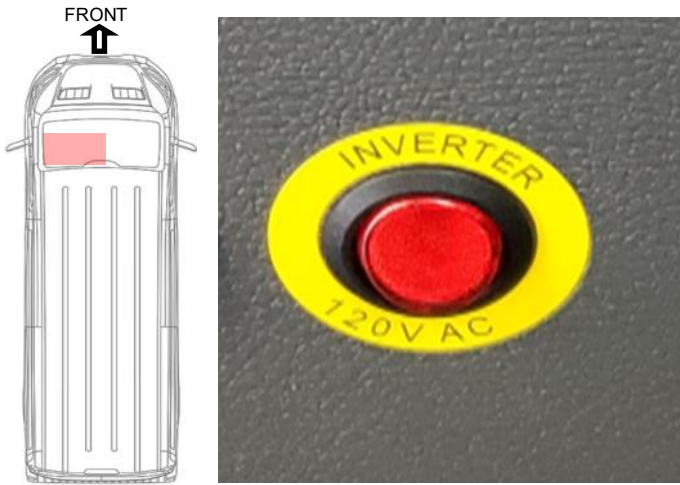

- Install the circular “INVERTER 120V AC” label at the red remote switch on the knee bolster panel.

### Step 10-2. Apply Remote Inverter Switch Label (67C KITS 62835 & 60323)



- Install the rectangular “INVERTER 120V AC” label at the upfitter Switch: AUX 1 in the center front seat counsel.

### Step 10-3. Apply Remote Inverter Switch Label



- Install the Blue Notice Label on the side of the inverter that is facing up after installation.

**\*NOTICE\***  
The power switch on this unit MUST be left in the REM (REMOTE) position to ensure correct operation of the inverter system. Changing the position of the switch can deplete the OEM batteries and require a jumpstart.

## Section 14: Labeling:

### Step 14-4. Apply Auxiliary Battery Caution Labels

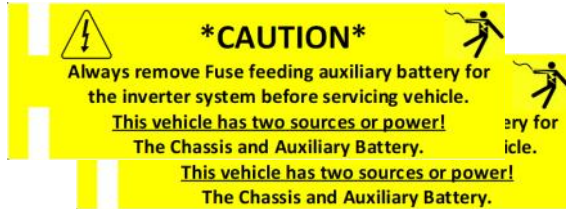
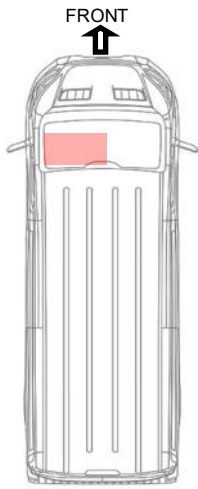

- Install the Yellow tag with Zip Tie to battery cables at OEM Battery and AUX 1 Battery.

## Section 11: Test and Check:

### Step 11-1. Test the inverter function



 Warning: Make sure all AC connections are made appropriately before power up.

#### Test: Verify Inverter Powers Up

- Ensure the INVERTER power switch is set to “REMOTE” [Black Switch]
- Start the engine or turn ignition to “ON” position.
- Turn on the remote inverter switch in the dash.

#### What to expect:

- Verify all three round green LEDs light up green with nothing plugged in [See Yellow Arrow].
- If any of the LEDs are not Green, turn off the system and check all wiring.

### Step 11-2. Check GFCI Operation

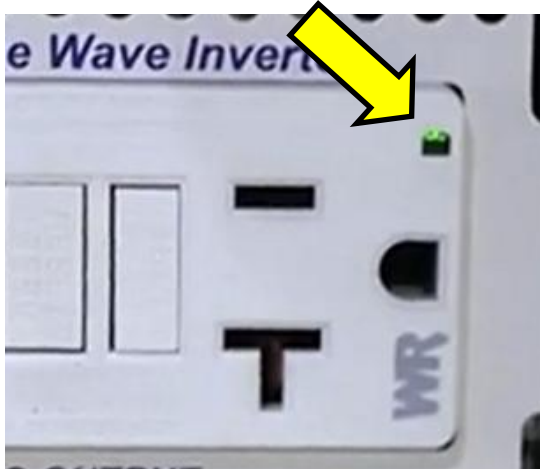

#### • Test: Verify GFCI Light is Green.

- While the inverter is powered, confirm the GFCI green light is on. Again- nothing should be plugged in.
- What to expect:
- If the light is Green, go to the next step
- If the light is red, push the GFCI RESET button. This should reset the device to green.

### Step 11-3. Test the inverter power output



#### Test: Insert Inverter Output.

- **Plug in** any accessories such as power strips included with the kit.
- Utilize and extension cord with the Voltage meter into one of the outlets on the inverter. Alternately a GFCI outlet Tester will indicate any faults.

#### What to expect:

- The power output should be at correct voltage and polarity. A reading of 114Vac – 122Vac is expected.
- If voltage is not in that range please STOP and notify Team Lead.

## Section 11: Test and Check:

### Step 11-4. Routing and Clipping



- Turn off dash switch for transportation and leave the black inverter mounted switch in “REM”.
- Using the supplied wire ties make sure all wiring is secured and clear of sharp objects, moving parts, and heat sources.
- Ensure all trim removed in previous steps is secure and neat.

---

**INSTALLATION INSTRUCTIONS  
HAVE FINISHED**

## Section 12-A: Fleet Appendix-Wiring Diagrams

### NON-67C Wiring Diagram [KITS 68158, 66006 & 66008]:

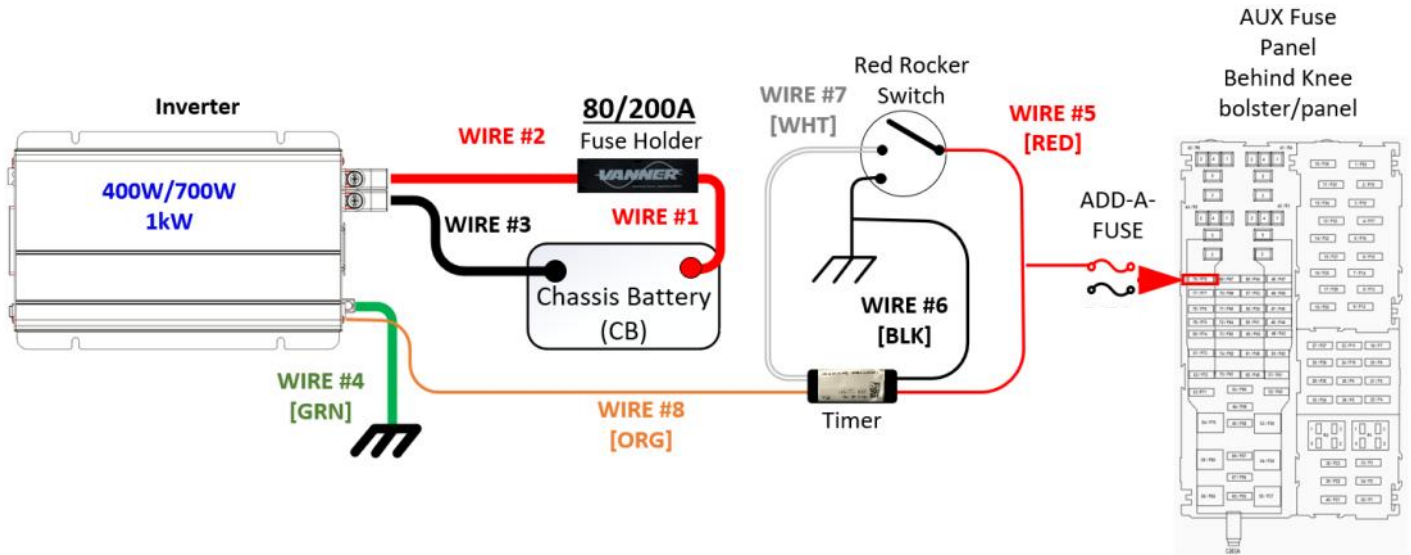

Figure 5-1: Complete Wiring Diagram [NON-67C Option KITS 68158, 66008 & 66006]

**NOTE:** New Fuse Box shape (on Pg.16) and fuse locations for MDY2026 and beyond.

### 67C Wiring Diagram [KITS 60323 & 62835]:

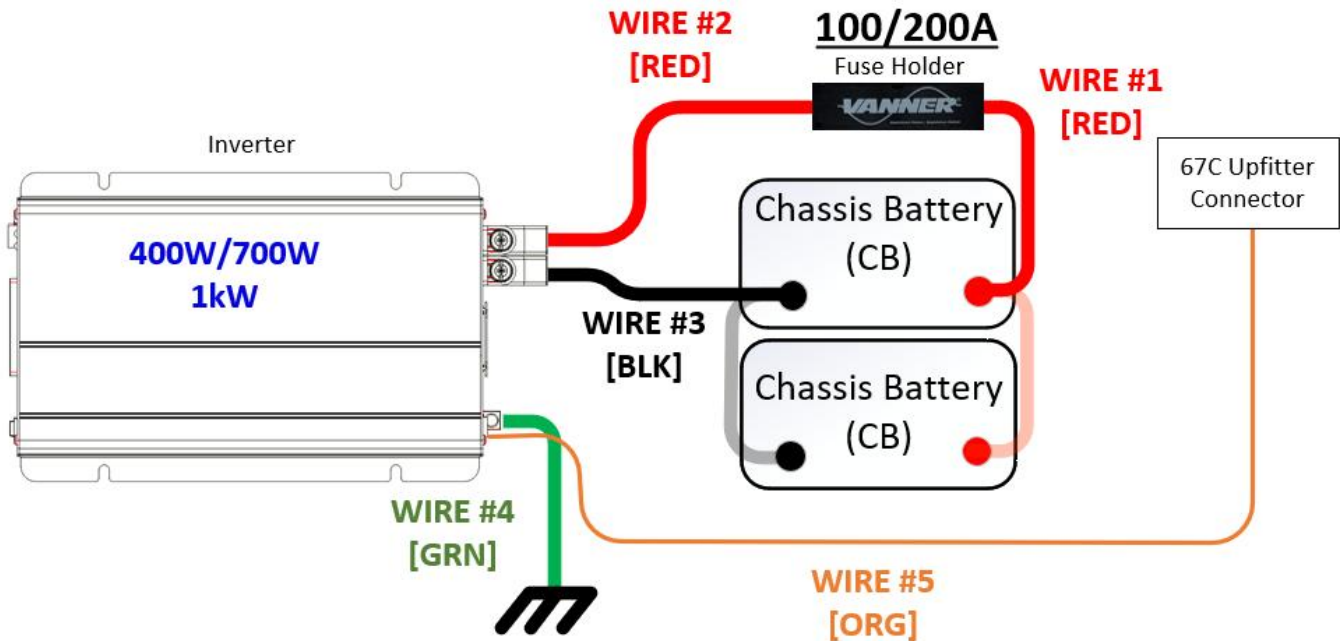

Figure 5-2: Complete Wiring Diagram [67C Option KITS 62835 & 60323]

## Section 12-A: Fleet Appendix– Tools Needed



1. Insulated Splice Crimper
2. Wire Strippers
3. Diagonal Cutters
4. Plastic Trim Tool
5. Drill driver
6. Measuring tape
7. Phillips Bit with Bit holder
8. 3/4" Hole or Step Drill (Unibit)
9. Medium and Small (-) Screwdriver
10. Large #3 Phillips (+) Screwdriver
11. Sockets:
  - 8mm
  - 10mm
  - 5/16"
  - 3/8"
  - 7/16"
  - 1/2"
  - 13mm
  - Socket driver and extensions
12. Torque Wrench [~8-20Nm range]
13. Tin Snips
14. #3 Philips (+) & Medium slotted torque socket
15. Marker [Not Shown]

Figure 3-1: Tools Needed for Installation

Figure 12-3: Tools Needed for Installation

## Section 12-A: Fleet Appendix– Additional Notes

### NOTES:

- Battery Negative is not disconnected for these procedures. For safety it is generally recommended, but Ford BBS suggests not unhooking unless the battery is being changed.
- Only insert large MEGA fusing when ready to check functionality of the system after is install.
- Be sure the MEGA fuse is correct size according to Inverter Cabling Kit PPDS.
- Installing on a Composite Partition requires extra procedure of installing accessory brackets.
- When installing on cargo side of partition, be sure cables are fed through the holes with grommets installed.
- The Green 8AWG WIRE [#10 for KIT 66007 & #7 for KITS 66221 and 62046] may need to be installed on mounting fastener of the inverter or other location if the partition does not have grounded fasteners holding it to chassis.

### DC Input Side Panel Wiring Diagram:

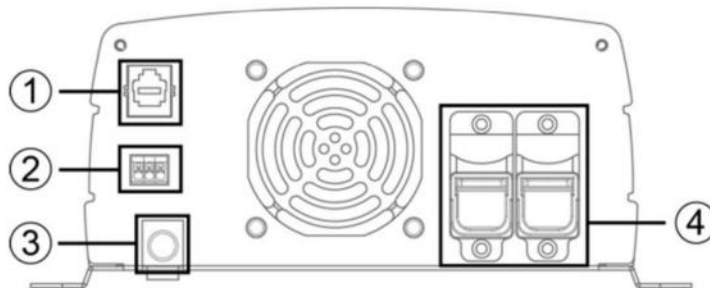

**TS-700W and TS-1000W**

Model	TS Series
①	Factory Port
②	Remote control black terminal
③	Chassis ground
④	DC input connector

Figure 12-4: Inverter Wiring Connections

## Section 12-A: Fleet Appendix- Kit Fasteners and Torque Table

ITEM NO.	ASC PN	Description	PCS	Torque Range	Use Wrench or Size
1	BAG0406-A	4" x 6" 3MIL AUTOBAG	1	--	
2	FAS0055	Nut, Hex Flange, Nylock 1/4-20	4	12Nm [+/- 1.8Nm] (106lb.in).	7/16"
3	FAS0018	SCREW, HH SFLNG 1/4-20X.62 ZP	4	12Nm [+/- 1.8Nm] (106lb.in).	7/16"
4	FAS0159	NUT, HEX TPLK M6X1.0	2	8Nm [+/- 1.2Nm] (71l b.in).	10mm
5	FAS0148	Screw, Self Drill/Tap, Pan Ph. Hd., #10x0.5, NI-ZN	1	3Nm [+/- 0.5Nm] (27lb.in).	#2 Phillips

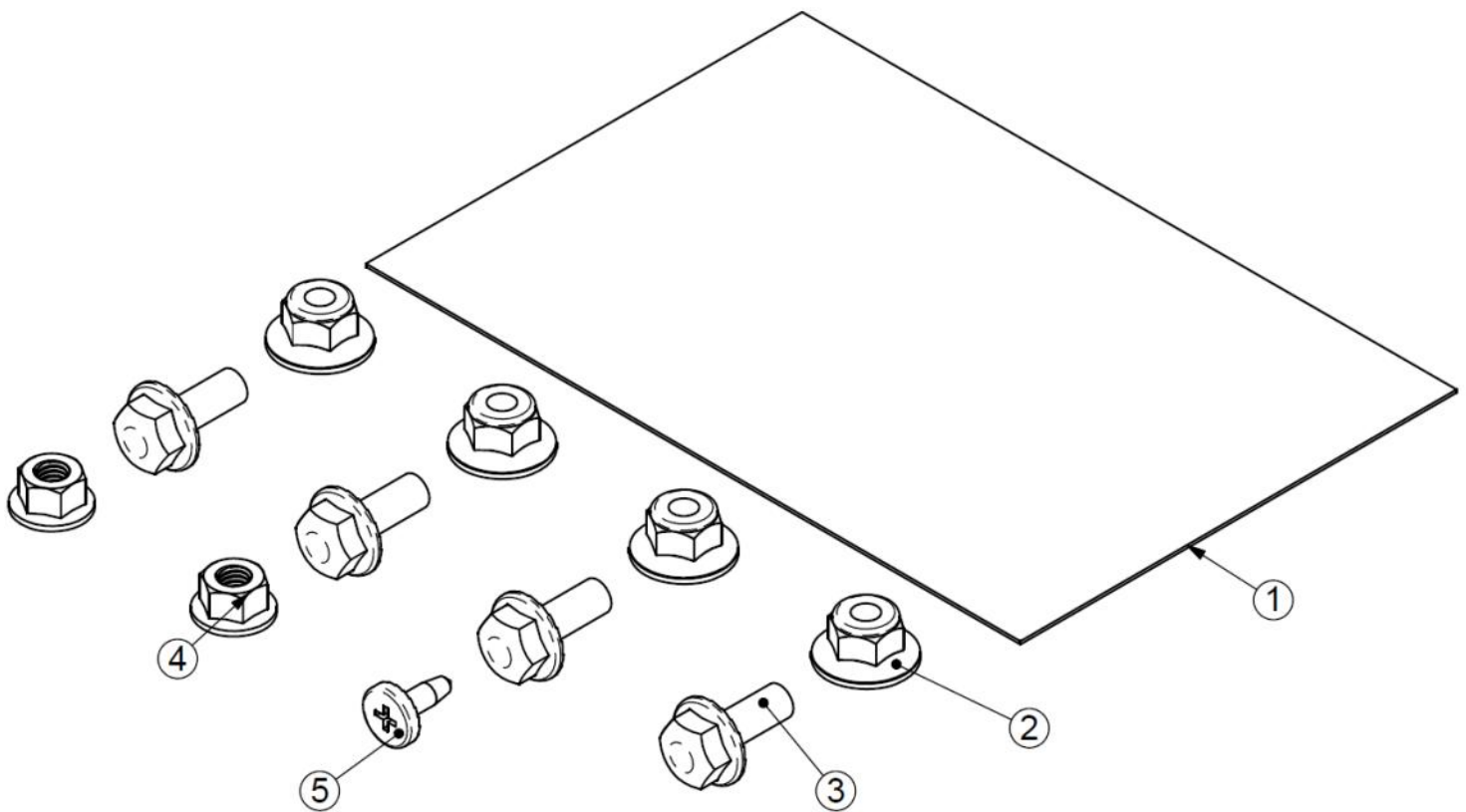

Figure 12-5: Fasteners included in Kit

## Section 12-A: Fleet Appendix- Kit Fasteners and Torque Table

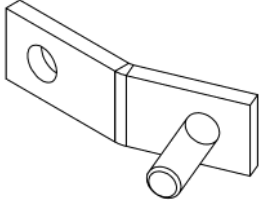

Ref. NO.	ASC PN	Description	PCS	Torque Range	Use Wrench or Size
6	Positive Battery Terminal busbar		1	8Nm [+/- 1.2Nm] (71 lb.in).	5/16"
7	Positive Battery Terminal busbar		1	-Will USE FAS0159 will be 8Nm [+/- 1.2Nm] (71 lb.in).	—
8	Cables to VANNER Fuse Holder		4	12Nm [+/- 1.8Nm] (106lb.in).	1/2"
9	Chassis Battery Fuse Holder to bracket nuts [KEPS]		2	3Nm [+/- 0.5Nm] (27lb.in).	3/8"
10	Inverter +/- Terminals	Phillips and slotted screws	Three (3) Positions	8Nm [+/- 1.2Nm] (71 lb.in).	#3 Phillips and 1/4" Standard driver bits
<b>Other Fasteners in Vehicle</b>					
11	CB Positive Battery Post Clamp	—	1	8Nm [+/- 1.2Nm] (71 lb.in).	10mm NUT
12	CB Negative Battery Cable to Battery Clamp	—	1	8Nm [+/- 1.2Nm] (71 lb.in).	13mm Nut
13	AUX positive and negative terminal fasteners	—	2 or 4	8Nm [+/- 1.2Nm] (71 lb.in).	1/2" Nut
14	Fuse holder & Battery Hold Down Bracket	—	2	10Nm [+/- 1.5Nm] (89 lb.in).	8mm Screw

Figure 12-6: Fasteners included in Kit