

AD SERIES RAIL SYSTEM INSTALL INSTRUCTIONS

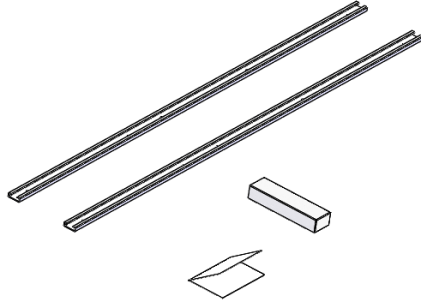

58607

**RAIL KIT, GM155 CS
ONLY**

ECN- 22112 DWG.BY: BTS

REV.BY: N. Weeden

ISSUE: A

P.N.: 58634

BEFORE YOU START!

IMPORTANT INSTALLATION STEPS ARE DENOTED USING A STOP SIGN. THESE STEPS MUST BE PERFORMED AS SPECIFIED IN ORDER TO ENSURE A PROPER INSTALLATION AND MUST BE FOLLOWED IN ORDER TO MAINTAIN YOUR PRODUCT WARRANTY!



CRITICAL INFORMATION PERTAINING TO USER AND/OR VEHICLE SAFETY IS DENOTED USING A CAUTION SIGN. SAFETY ITEMS MUST BE STRICTLY ADHERED TO IN ORDER TO ENSURE A SAFE WORKING ENVIRONMENT!



YOU WILL NEED THE FOLLOWING TOOLS IN ORDER TO COMPLETE THIS JOB.

3/16 ALLEN	9/16" OPEN END WRENCH FOR SETTING PLUSNUTS, DRILL MOTOR, 1/2" DRILL BIT WITH 1/2" DEEP STOP
1/2" OPEN END WRENCH	RATCHET WRENCH, WITH 1/2" SOCKET

ALL FASTENERS USED IN THE ASSEMBLY AND INSTALLATION OF THIS PRODUCT SHOULD BE TIGHTENED TO THE SPECIFIED TORQUE AS LISTED WITH EACH FASTENER CALLOUT BOX.



THE USE OF AIR OR ELECTRIC IMPACT TOOLS FOR THE ASSEMBLY OF FASTENERS IS NOT RECOMMENDED AND COULD CAUSE FASTENER FAILURE!



WARNING



THE USE OF DRILLS WITH INTEGRAL DRILL STOPS ALONG WITH PROPER INSPECTION FOR GAS TANK, GAS LINES, BRAKE LINES AND ELECTRICAL LINES PRIOR TO DRILLING ANY MOUNTING HOLES IS STRONGLY RECOMMENDED TO ENSURE THAT VEHICLE DAMAGE IS AVOIDED!



THE USE OF NON-STANDARD FASTENERS AND/OR DEVIATING FROM THE FASTENERS SPECIFIED IN THE INSTRUCTION (S) MAY VOID YOUR PRODUCT WARRANTY!

ALL DRILLED HOLES IN THE VEHICLE SHOULD HAVE THE RAW METAL EDGES SEALED WITH A SELF-ETCHING PRIMER TO RESIST CORROSION AND POTENTIAL FASTENER POINT FAILURE!



TO PREVENT EXHAUST FUMES FROM ENTERING THE VEHICLE, ALL HOLES SHOULD BE SEALED AT INSTALLATION WITH BUTYL OR SILICON SEALANT MATERIAL.



Whenever a plusnut is specified it is important that the proper size installation hole is provided.

PLUSNUT SIZE	DRILL SIZE (with stop)
5/16-18 PLUSNUT, FAS0091 	1/2" DIAMETER

FOR MOUNTING THROUGH A FLOOR MAT AND/OR CARPET

Position each item in desired location inside the vehicle and mark the floor mounting locations.

It is recommended that a drilling template be used to ensure an accurate placement of components is achieved for this installation.

Using the cutting tool, drill a pilot hole thru the mat/carpet and metal floor pan.

Spacer Use and Installation

3927-1 (SHOWN)

ALWAYS PLACE RECESSED PART OF FLOOR SPACER ON TOP OF PLUSNUT.

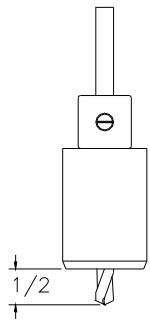

Placing the properly sized spacer on top of the vehicle floor pan will make your Adrian interior level, square, and sound. The view below shows the proper sized spacer for the different heights of the vehicle floor. Make sure to place the spacers with the plusnut relief surface down as shown.

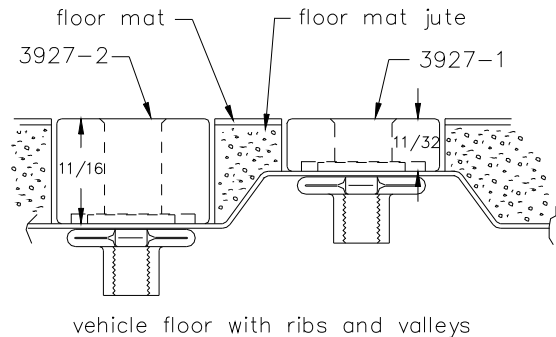
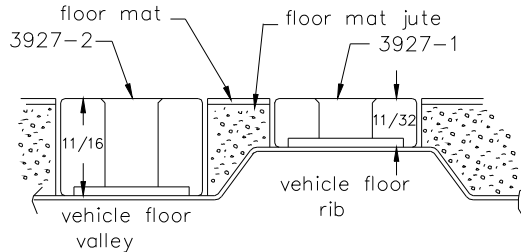

The location of various floor mounts will determine what spacer combination will be used. For example, an 11/32" spacer is used atop floor ribs, and an 11/16" high spacer is used atop floor valleys.





THE PROPER USE OF SPACERS IS REQUIRED WHEN MOUNTING OVER MAT/CARPET TO ENSURE THE METAL-TO-METAL CLAMP-UP, WHICH WILL PREVENT UNWANTED COMPONENT SHIFTING AND POTENTIAL FAILURE DURING USE.



STEP – 01

VEHICLE PREPARATION, FLOOR MOUNTING LOCATIONS

 <p>03927-1 1 1/32 C/F 1006 SPACER (5) REQUIRED ONLY WHEN OEM MAT IS USED</p>	 <p>FAS0091 5/16" PLUSNUT (5) REQUIRED</p>	 <p>22200-0 PLUSNU T TOOL</p> <p>NOTE: PLUSNUT TOOL NOT SUPPLIED WITH THIS KIT. ORDER PLUSNUT TOOLS FROM ADRIAN STEEL OR USE INSTALLATION TOOLKIT 31291- 0</p>
---	--	--

Using 1/2" drill bit with drill stop drill holes at the marks you made in the van floor.

Clean up debris from drilling and Install a 5/16" plus nut into each hole and set the plusnut as shown in illustration.

ASSEMBLE THE FOLLOWING

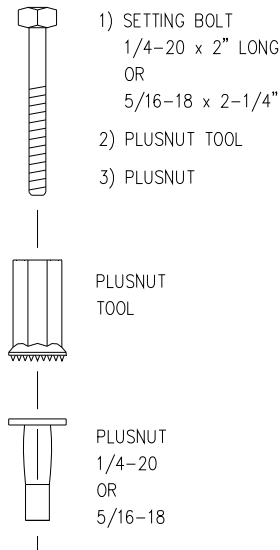

SETTING THE PLUSNUT

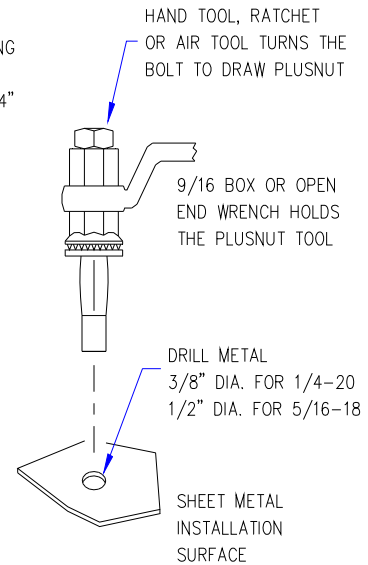

1. REMOVE D-RINGS FROM VEHICLE FLOOR PER DIAGRAM BELOW, USE A TORX 50 TO REMOVE OEM FASTENER.

135" WB

135" & 155"
REMOVE (D-SIDE 2
LOCATIONS.)

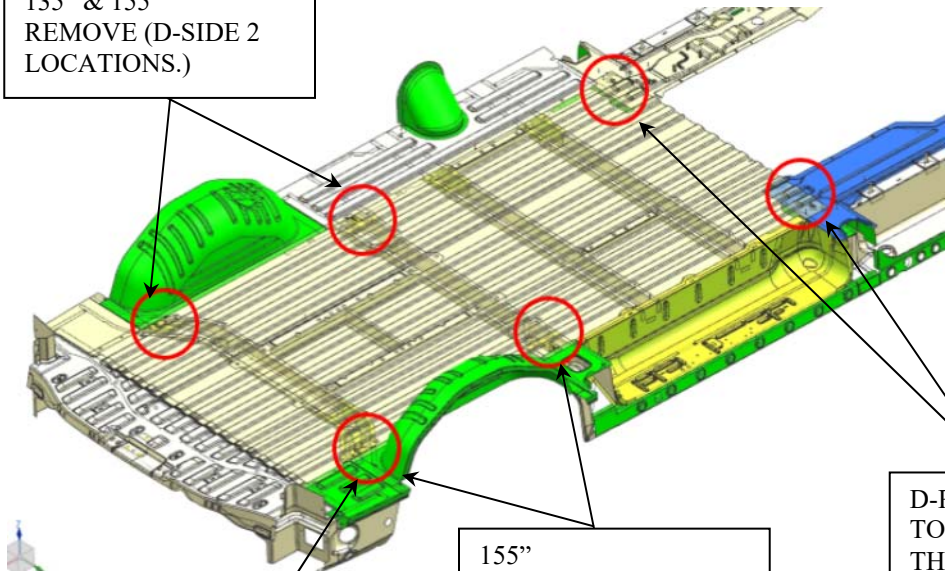

D-RINGS DO NOT NEED
TO BE REMOVED IN
THESE TWO LOCATIONS.

135"
REMOVE (P-SIDE, 1
LOCATION.)

155"
REMOVE (P-SIDE, 2
LOCATIONS.)

2. RE-INSTALL FASTENER – STOW D-RINGS FOR END USER, OR AS SPECIFIED PER PDS.

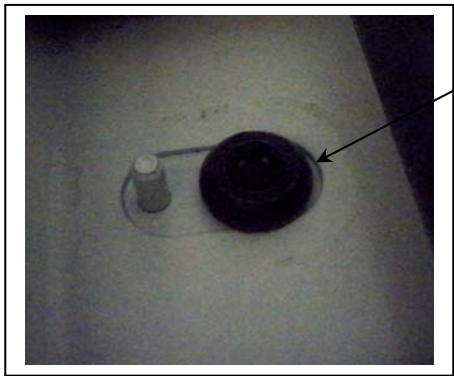







OEM FASTENER

IF EQUIPED WITH
WORKMAT, PLACE FOLD
UNDER RAIL DURING
INSTALL



STEP – 02**INSTALL CURBSIDE FLOOR RAIL**

 <p>FAS0091 5/16" PLUSNUT (3) REQUIRED</p>	 <p>36502-0 70" RAIL XLWB (1) REQUIRED</p>	 <p>FAS0708 5/16-18 X1.25 SHCS (3) REQUIRED TORQUE 17ft lbs.</p>	 <p>FAS0085 5/16 EXT TOOTH WASHER (3) REQUIRED</p>	 <p>03927-1 11/32 C/F 1006 SPACER (3) REQUIRED ONLY WHEN OEM MAT IS USED</p>
 <p>35335-0 SLIDE (2) REQUIRED</p>		 <p>36496-0 END CAP (2) REQUIRED</p>		

1. Slide rail so that it contacts wheel well as shown below. Measure 3.13" from the back end of the rail to the plastic trim as shown.



2. Measure in the rear 11.25" to wall from outside edge of rail. Measure in the front 8.25" to wall from outside of rail as shown.



STEP – 02

INSTALL CURBSIDE FLOOR RAIL CONTINUED

3. Mark (3) holes. Remove rail. Drill and set plusnuts.

4. Install rail using fasteners called out above

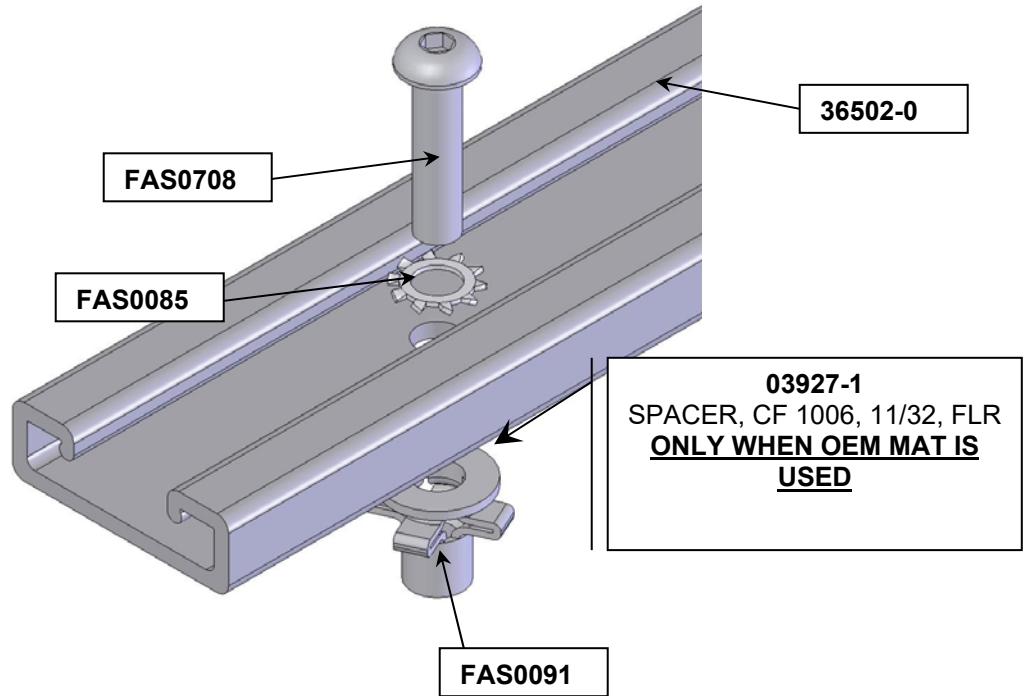



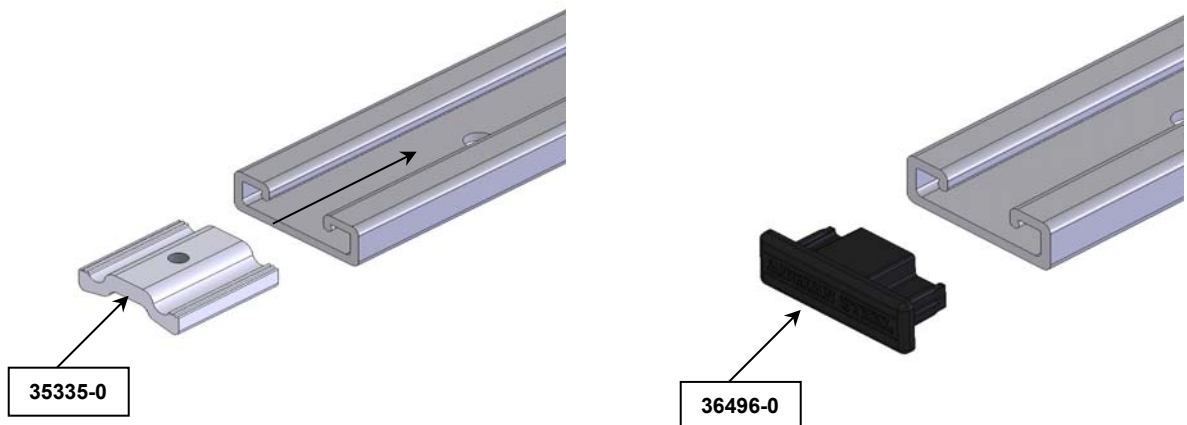









5. Insert (2) slides and (2) end caps into rail.

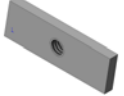

STEP – 03

INSTALL CURBSIDE UPPER RAIL

 <p>FAS0091 5/16" PLUSNUT (2) REQUIRED</p>	 <p>36502-0 70" RAIL XLWB (1) REQUIRED</p>	 <p>FAS0708 5/16-18 X 1.25 (1)REQ LWB (2)REQ XLWB TORQUE 17ft lbs.</p>	 <p>FAS0085 5/16 EXT TOOTH WASHER (5) REQ LWB (6)REQ XLWB</p>	 <p>FAS0093 5/16-18 X 1.25 (2) REQUIRED TORQUE 17ft lbs.</p>	 <p>FAS0086 5/16 WASHER (3) REQUIRED</p>	 <p>36503-0 RETAINER BAR (1)REQ LWB (2)REQ XLWB</p>
 <p>36500-0 MOUNTING BRACKET (1) REQUIRED</p>		 <p>03961-1 MOUNTING BRACKET (1) REQUIRED</p>	 <p>35335-0 SLIDE (3) REQUIRED</p>	 <p>FAS0165 5/16-18 X .625 (2) REQUIRED TORQUE 12ft lbs.</p>	 <p>FAS0135 5/16-18 NUT (1) REQUIRED</p>	

1. Locate hex hole in rear upper rear corner by removing wire holder. Drill and set plusnut. On rear side of the C-pillar measure up 44" from the top of the floor rail mark and drill for plusnut. Install plusnut as shown below



Picture used for reference only

2. Place retainer bar into the hole(s) that match up with rib(s).

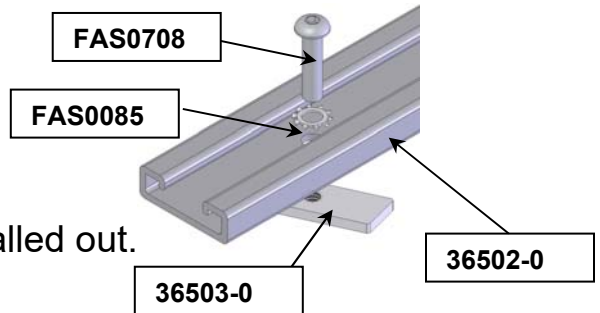

Install retainer bar to the rail using fasteners called out.

STEP - 03**INSTALL CURBSIDE UPPER RAIL CONTINUED**

3. Install rail onto curbside of van by placing retainer bar into upper slot in rib. Measure 44." to the center of the upper rail from the top of the floor rail in both the front and the rear. Tighten the (1) retainer bar fastener down checking the 44" measurement. The rail may need to be repositioned to be able to fasten the shelving unit to the upper rail. Insert (3) slides into rail.

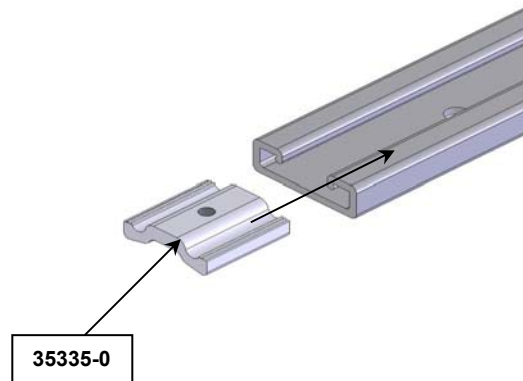
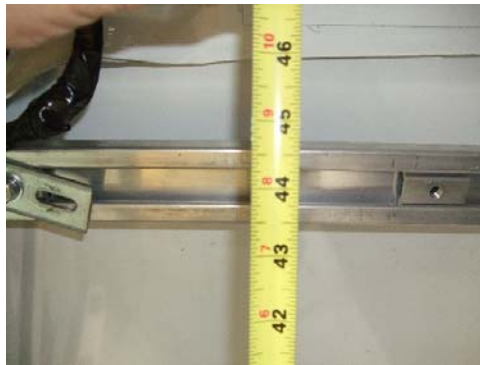

4. Install Front and rear brackets as shown below. The front bracket is attached to the rail with nut and bolt. The rear bracket is installed the same as the streetside. Secure O.E.M. harness to the bracket with a wire tie at the wire holder.

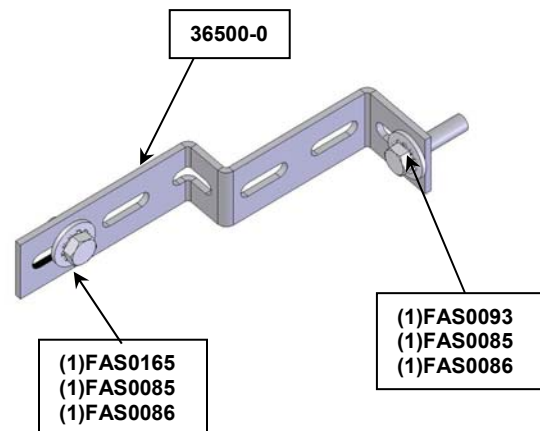
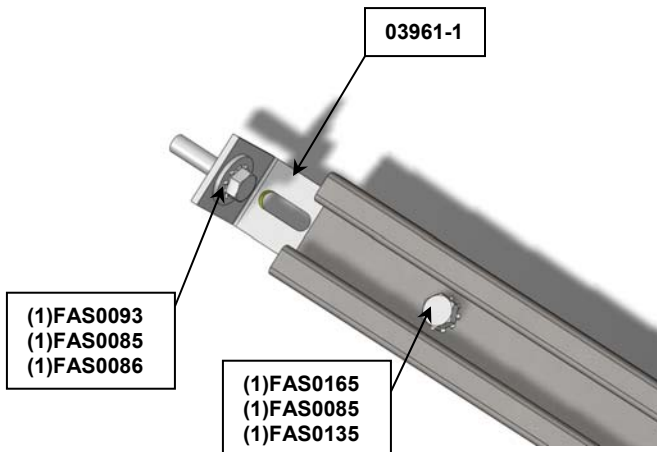

DOUBLE-CHECK ALL FASTENER LOCATIONS TO BE SURE THAT ALL FASTENERS ARE TIGHTENED TO SPECIFICATIONS!



YOUR INSTALLATION IS NOW COMPLETE! STOW THIS COPY IN THE VEHICLE FOR FUTURE REFERENCE!