

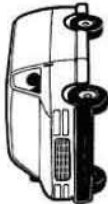

ADRIAN STEEL®

GM/CHEVROLET FULL SIZE VAN

Will not work with SEO Option 8G8



47917

REGULAR WHEEL BASE LEFT DOOR CARGO VAN

Penda Part #	Adrian Steel #	Description	Qty.	Code
GMVS018	47921-0	HEADLINER, FRONT 2015 GM LWB	1	B
GMVS019	47922-0	HEADLINR SEAM STRIP 2015 GM FSV	2	C
GMVS006	28832-0	SS RR PANEL, POLY LNR GM LWB/XLWB	1	E
GMVS014	28846-0	DOOR HEADER TRIM CBSD POLY LINER GM	1	G
GMVS003	28833-0	CS PANEL, POLY LINER GM LWB	1	H
GMVS007	28837-0	JACK COVER, POLY LINER GM FSV	1	K
GMVS004-1	28834-0	SS FRT PANEL, POLY LINER GM LWB	1	J
GMVS017	47920-0	HEADLINER, FRONT 2015 GM LWB	1	Q
PA0982	28843-0	INSTALL KIT GM/CHEV FULL SIZE VAN	1	

47918

EXTENDED WHEEL BASE LEFT DOOR CARGO VAN

Penda Part #	Adrian Steel #	Description	Qty.	Code
GMVS021	47924-0	HEADLINER, REAR, 2015 GM XLWB	1	B
GMVS019	47922-0	HEADLINR SEAM STRIP 2015 GM FSV	2	C
GMVS006	28832-0	SS RR PANEL, POLY LNR GM LWB/XLWB	1	E
GMVS014	28846-0	DOOR HEADER TRIM CBSD POLY LINER GM	1	G
GMVS001	28831-0	CS PANEL, POLY LINER GM XLWB	1	H
GMVS005-1	28835-0	SS FRT PANEL, POLY LINER GM XLWB	1	J
GMVS007	28837-0	JACK COVER, POLY LINER GM FSV	1	K
GMVS020	47923-0	HEADLINER, FRONT 2015 GM XLWB	1	Q
PA0982	28843-0	INSTALL KIT GM/CHEV FULL SIZE VAN	1	

INSTALLATION KIT

Penda Part #	Adrian Steel #	Description	Qty.	Code
380015	41402	JACK NUT	4	A
380014	41403	THUMB SCREW	4	D
PA0987	41407	PLASTIC CAP RH-10 SILVER	52	M
PA0836	FAS0345	SCREW #8 3/4" PHILIPS TRUSS HEAD	56	N
PA0989	FAS0346	WASHER STEEL ZINC PLATE RH-W10	52	O
PA0954	41404	NYLON SPACER	24	R
PA0988	48368	FOAM STRIP GMT600 CARGO VAN	1	P
590129	41409	INSTRUCTION SHEET GMT 600 CARGO VAN	1	

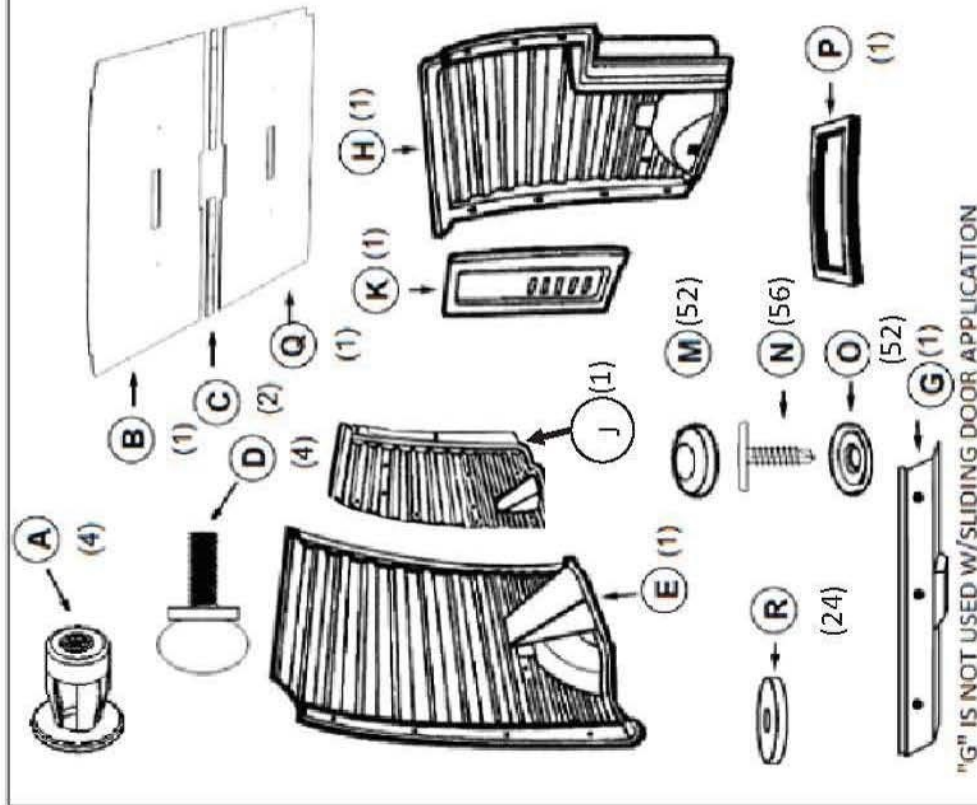

"G" IS NOT USED W/SLIDING DOOR APPLICATION

If the E track is being installed, use instruction sheet

LWB = 29726-0

EWB = 29727-0



ADRIAN STEEL COMPANY
906 James Street, Adrian, MI 49221-3996
(517) 265-6194 • Fax: (517) 265-5834
Toll Free: (800) 362-7611

ECN 21544	DATE 12/19/19	ISSUE E	POLY LINER KIT GM LWB 47917	GMEWB 47918
--------------	------------------	------------	--------------------------------	-------------

Skip this step if installing Adrian Steel composite partition.

POLY LINER MODIFICATION FOR ADRIAN STEEL PARTITION/BULKHEAD

******* DO THIS STEP FIRST *******

1. NOTCH FRONT UPPER CORNER OF STREET SIDE FRONT PANEL.

* 28834-0 REGULAR WHEELBASE

* 28835-0 EXTENDED WHEELBASE

2. CUT OUT SECTION SHOWN BELOW FOR PARTITIONS W/5 DIGIT
PART NUMBER 38936 THROUGH 38943

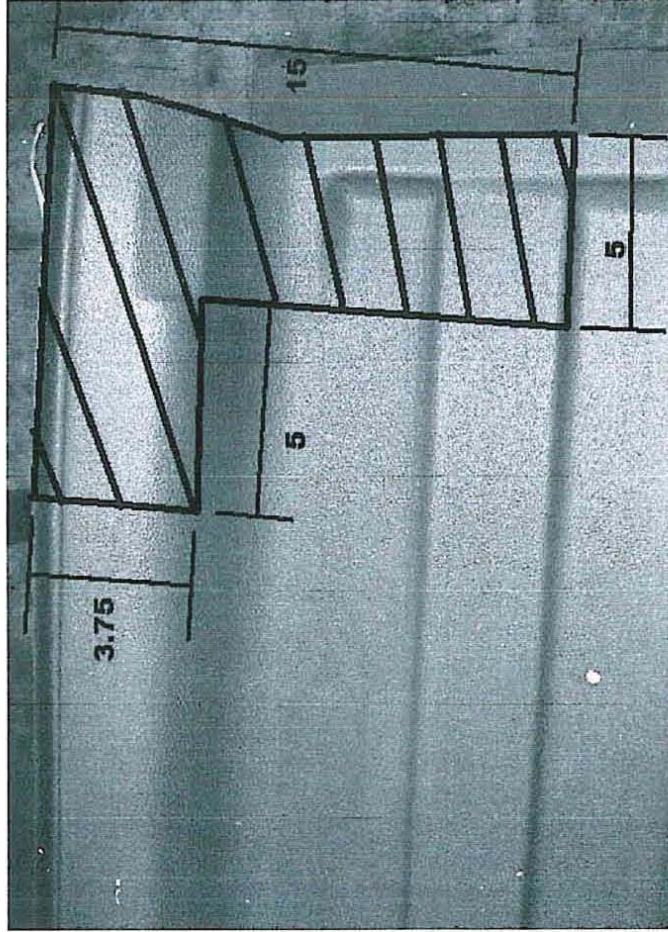

3. CUT OUT SECTION SHOWN BELOW FOR PARTITION W/9 DIGIT PART
NUMBER (S_M_C_FSV).

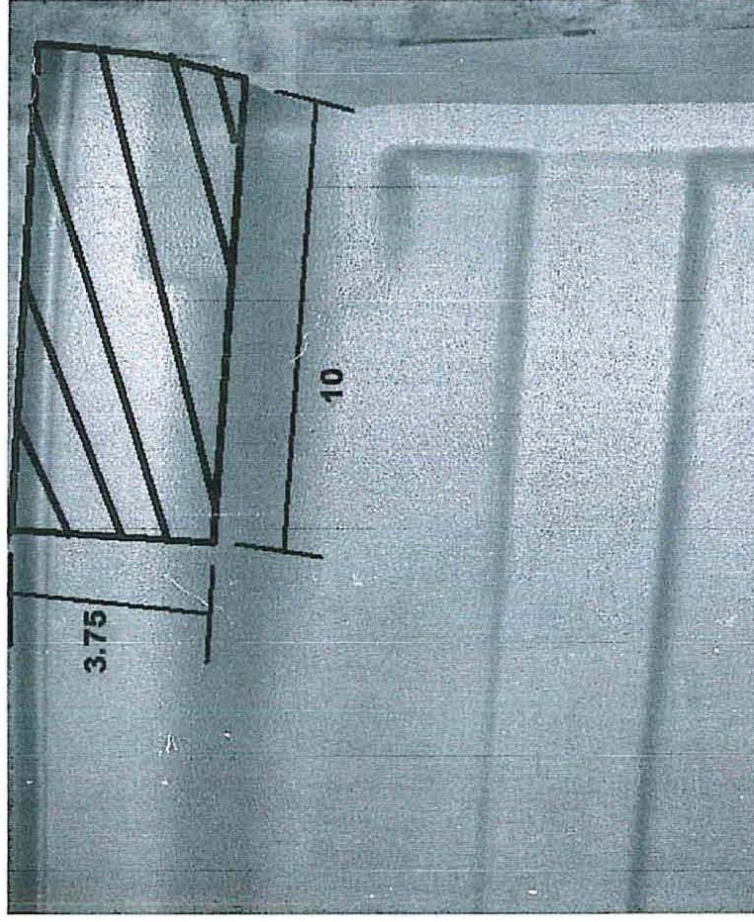

4. INSTALL LINER PACKAGE.

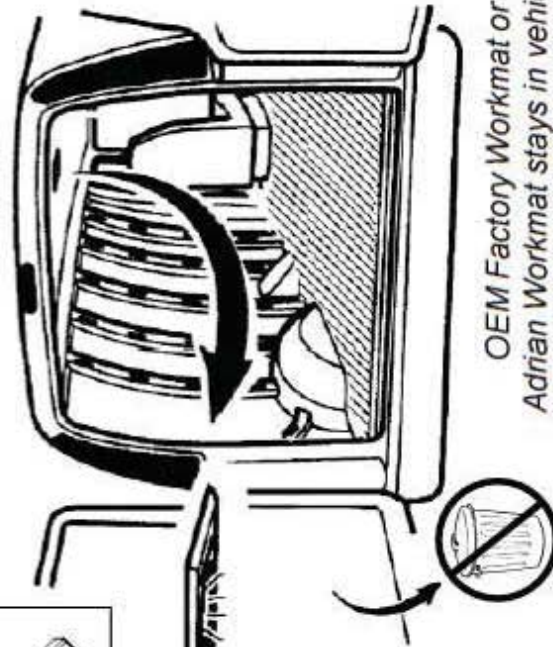

OEM Factory Workmat or
Adrian Workmat stays in vehicle.

1

REMOVE
FACTORY
CORNER
TRIM

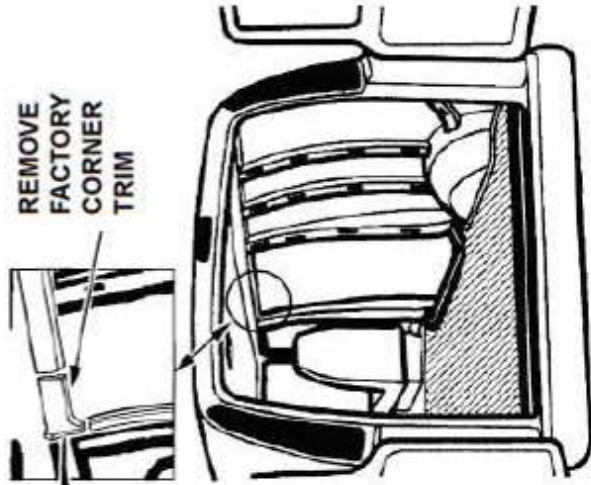

2

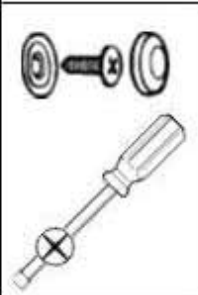

E-TRAC USERS ONLY FASTEN

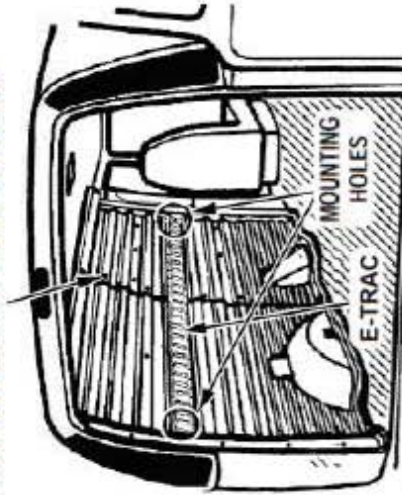

AFTER INSTALLATION OF E-TRAC MOUNTING BRACKETS,
ALIGN PANEL HOLES & LOOSELY FASTEN E-TRAC FRONT &
REAR. ADJUST PANEL RIDGES PARALLEL TO E-TRAC. FASTEN
ONE LOCATION ABOVE E-TRAC TO SECURE, TIGHTEN E-TRAC
MOUNTING BOLTS & CONTINUE AT STEP 5.

3a

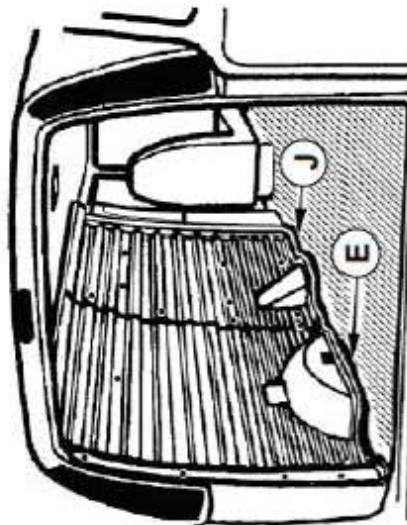

PLACE & FIT PANELS IN VAN AS SHOWN.
PANEL "J" INSTALLS OVER PANEL "E".

Panels fit over Workmat.

3

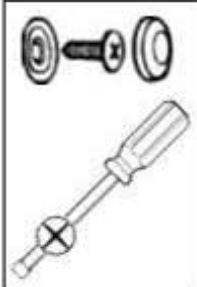

FASTEN

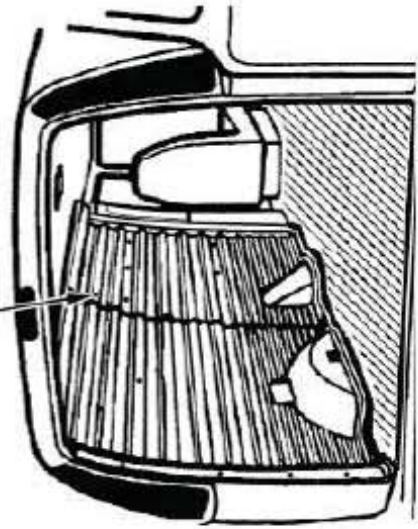

WHILE HOLDING BOTH PANELS,
FASTEN ONE LOCATION TO SECURE.

4

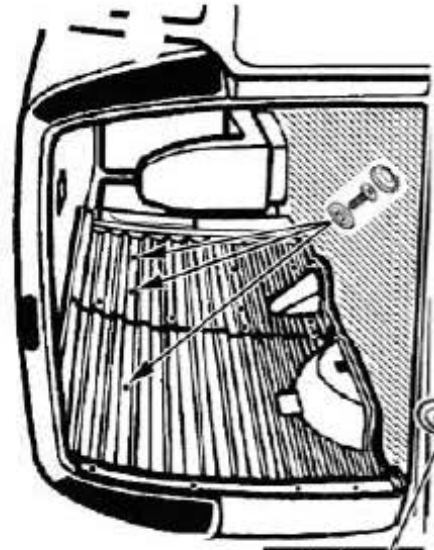

6



INSTALL THRU
BOTH PANELS J & E

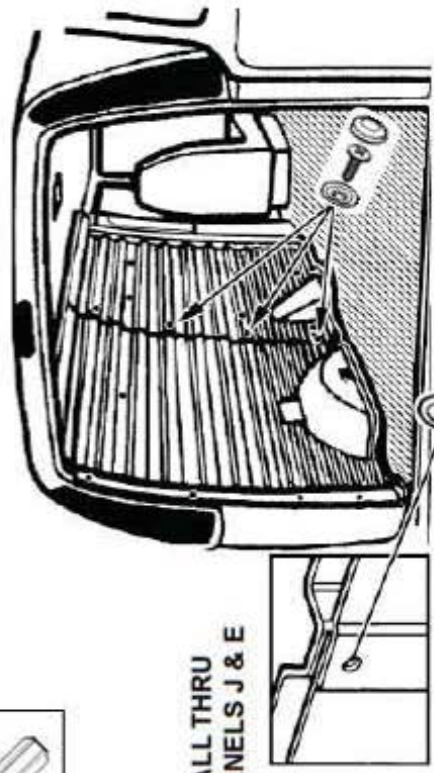

5

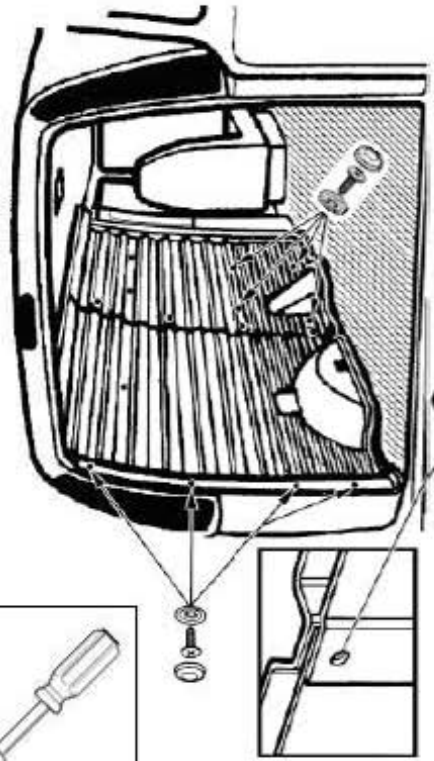

7

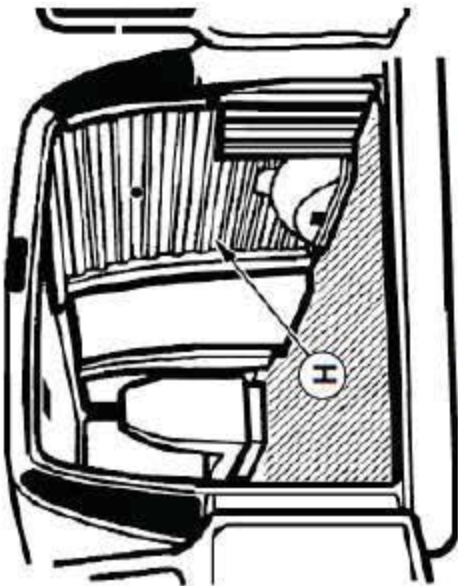

PLACE & FIT PANEL IN VAN AS SHOWN.
RWB SHOWN

**NOTE: E-TRAC USERS
REFER TO SAME PROCEDURE
AS STEP #3a**

8

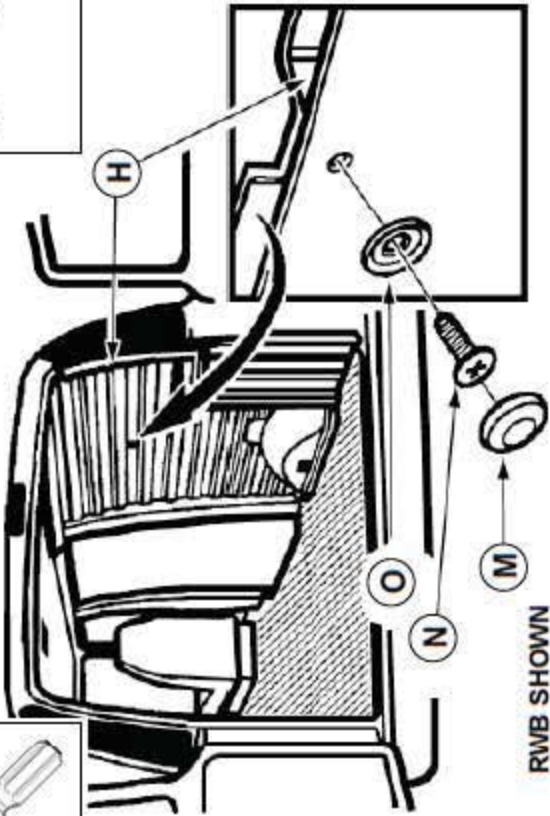

9 RWB SHOWN

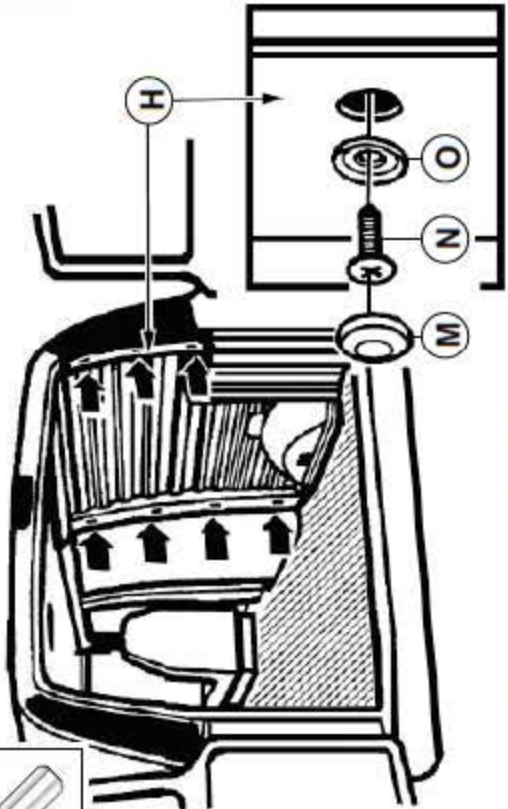

10 INSTALL SCREWS AT SEVEN (7) LOCATIONS

10



LINE UP JACK COVER AND MARK 4 HOLES TO
DRILL. DRILL OUT 4 - 7/16" HOLES AND
INSTALL JACK NUTS (A).

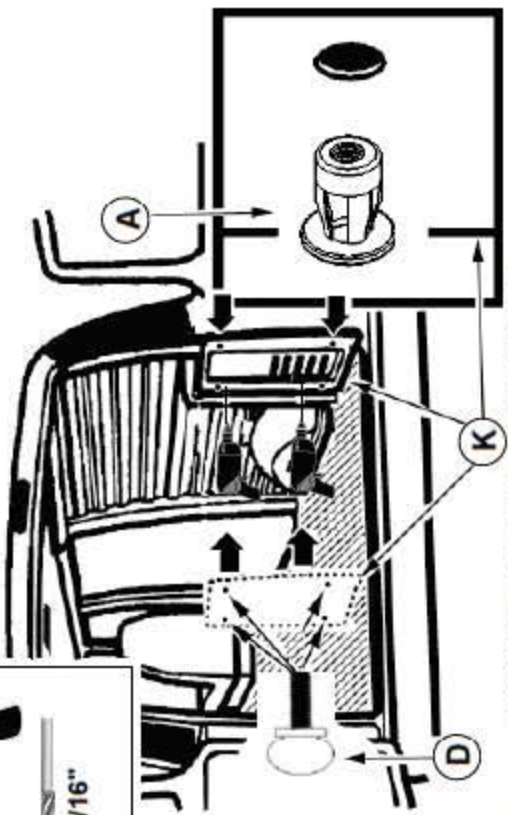

THEN USE THUMB SCREWS (D) TO
INSTALL JACK PANEL (K)

11



"G" IS NOT USED WITH SLIDING DOOR APPLICATION



12



INSTALL SCREWS W/SPACERS
AT FOUR (4) LOCATIONS

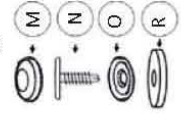
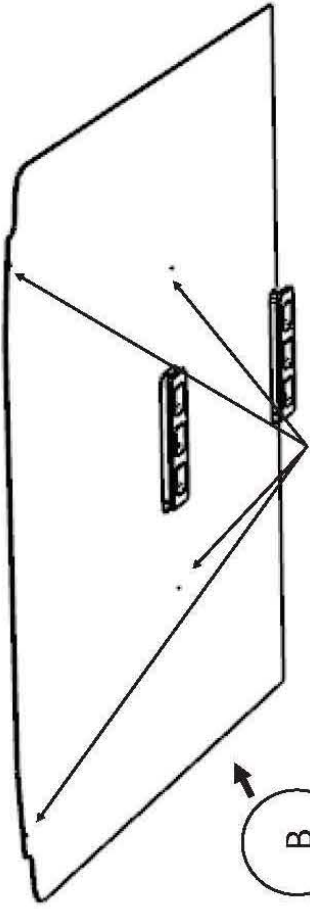

14

REAR

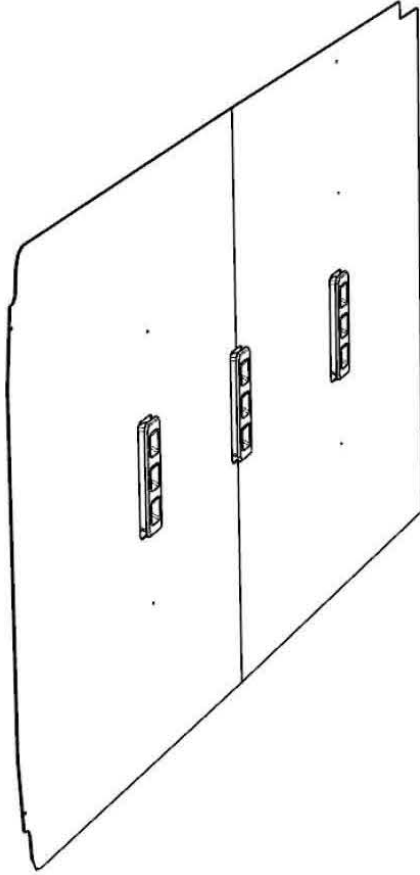

FRONT

PLACE HEADLINER OVER CEILING LIGHTS WITH REFLECTIVE BACKING
FACING THE CEILING.

NOTE: VERIFY HOLES ARE IN POSITION ON ROOF BOW WHERE
FASTENERS CAN BE SECURED PROPERLY.

13



NOTCHED CORNER
LOCATION

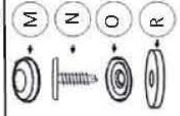
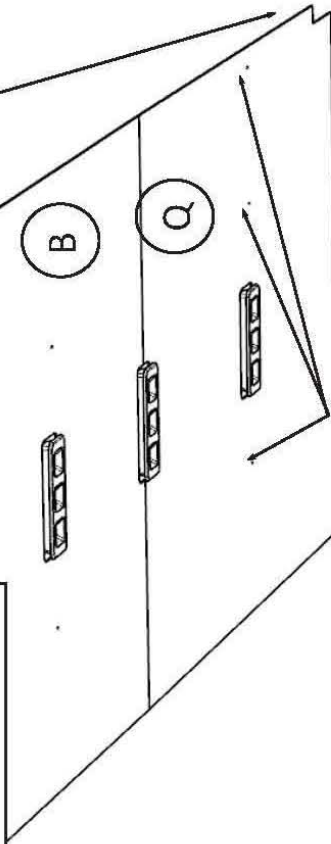

INSTALL SCREWS W/SPACERS
AT THREE (3) LOCATIONS

15

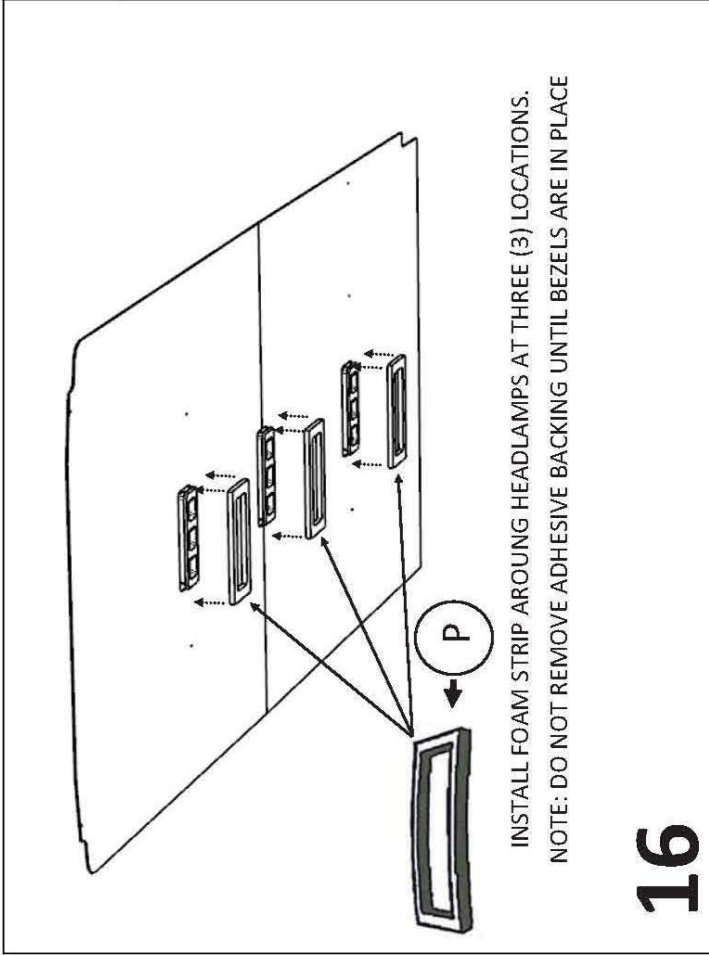

INSTALL FOAM STRIP AROUND HEADLAMPS AT THREE (3) LOCATIONS.
NOTE: DO NOT REMOVE ADHESIVE BACKING UNTIL BEZELS ARE IN PLACE

16

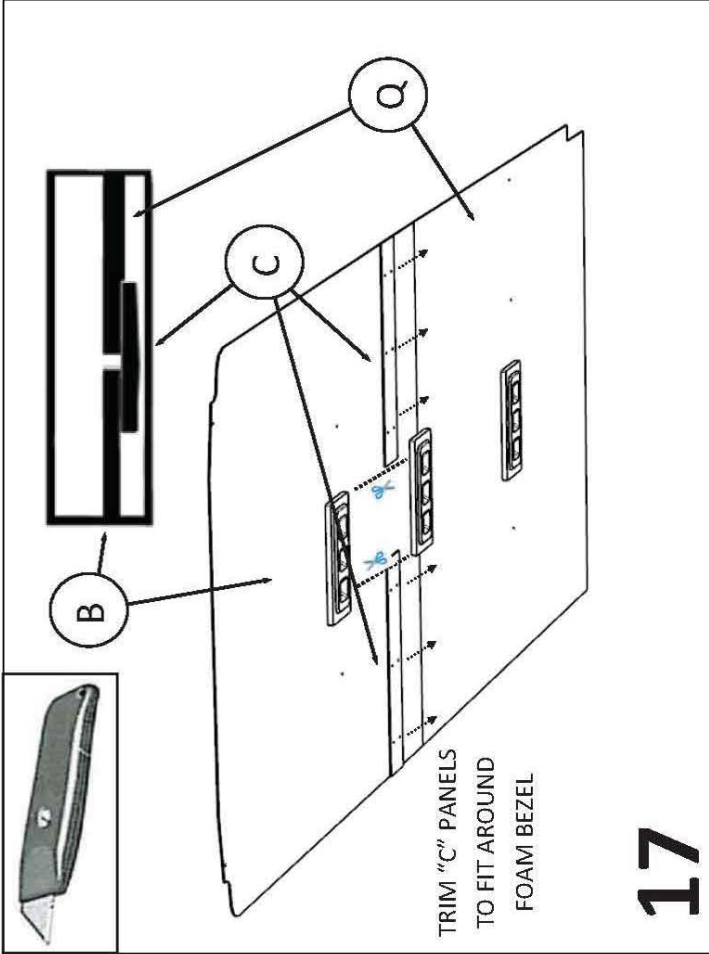

TRIM "C" PANELS
TO FIT AROUND
FOAM BEZEL

17

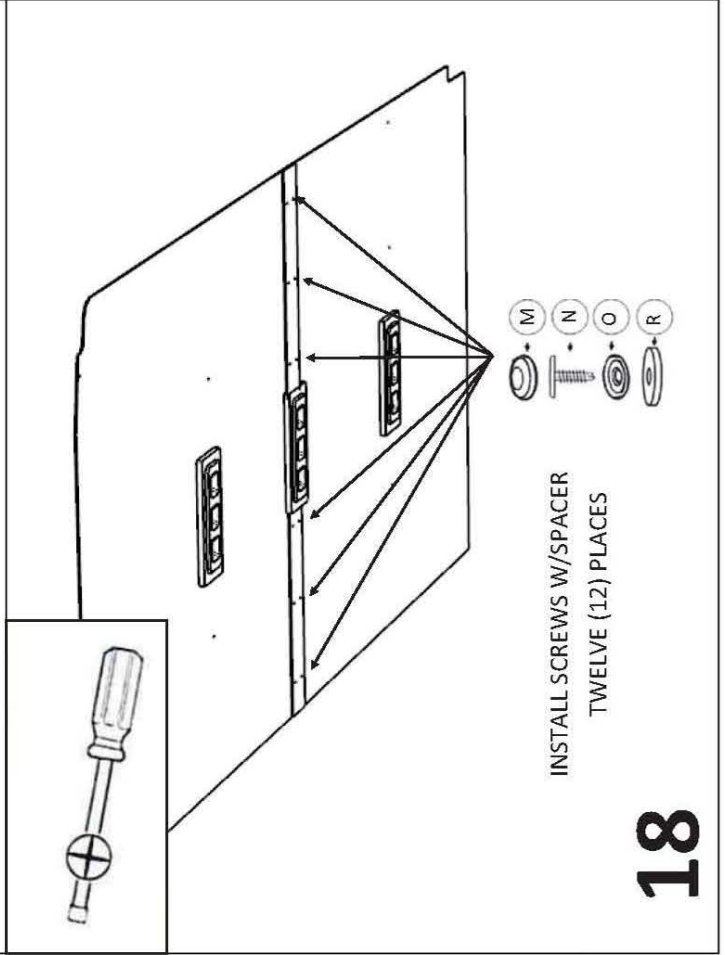

INSTALL SCREWS W/SPACER
TWELVE (12) PLACES

18

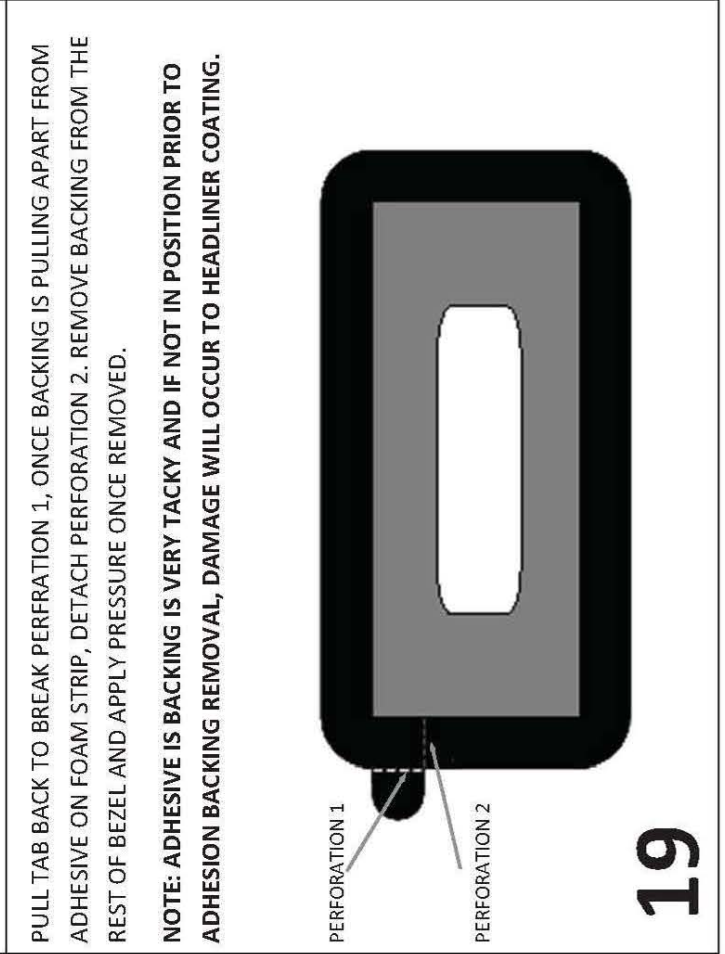

PULL TAB BACK TO BREAK PERFORATION 1, ONCE BACKING IS PULLING APART FROM ADHESIVE ON FOAM STRIP, DETACH PERFORATION 2. REMOVE BACKING FROM THE REST OF BEZEL AND APPLY PRESSURE ONCE REMOVED.

NOTE: ADHESIVE IS BACKING IS VERY TACKY AND IF NOT IN POSITION PRIOR TO ADHESION BACKING REMOVAL, DAMAGE WILL OCCUR TO HEADLINER COATING.

19



REVERSE SIDE OF FACTORY CORNER TRIM

BEFORE TRIMMING

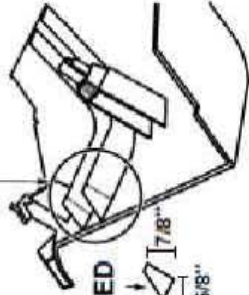

TRIMMED
PIECE ↓

7/8"
5/8"

AFTER TRIMMING

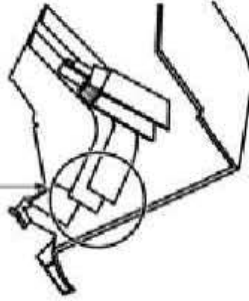

20

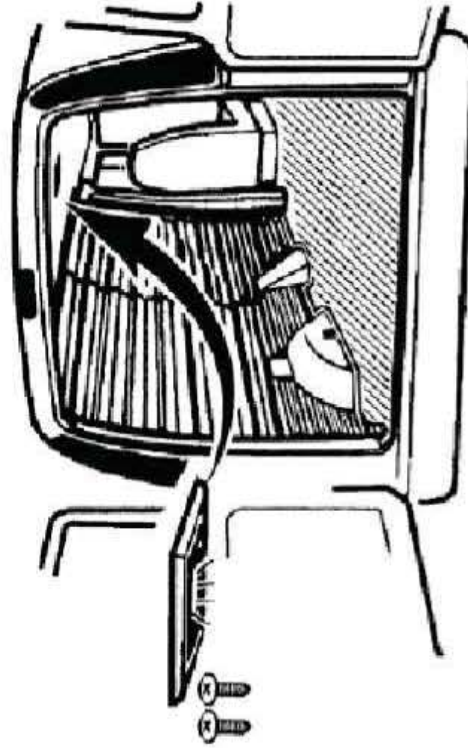

22



21

ITEM DESCRIPTION: INSTALL BAG,PLY LNR GMFSV



MANUFACTURER: PENDA
 MANUFACTURERS PART NUMBER: PA0982

SPECIFICATIONS: (4) JACK NUTS
 (4) THUMB SCREWS
 (20) NYLON SPACERS
 (52) #8 X 3/4" SCREWS (BAGGED)
 (48) WASHER STEEL ZINC PLATE RH-W10 (BAGGED)
 (48) PLASTIC CAP RH-10 SILVER (BAGGED)
 (1) FOAM STRIP GMT 600 CARGO VAN
 (1) INSTRUCTION SHEET GMT600 CARGO VAN

SPECIAL NOTES: THIS BAG IS USED IN POLY LINER KITS 28822-0 LWB, 28823-0 XLWB

SUPPLIED BY: THIS ITEM IS ADRIAN AVAILABLE!

PURCHASED PRODUCT DATA SHEET (PPDS)

THIS DRAWING/INFORMATION IS THE PROPERTY OF ADRIAN STEEL COMPANY AND IS NOT TO BE USED IN ANY MANNER THAT IS DETRIMENTAL TO THE INTEREST OF ADRIAN STEEL. COPYRIGHTS AND OR PATENTS THAT MAY BE THE PROPERTY OF APPLICABLE OWNERS MAY PROTECT INFORMATION AND/OR DRAWINGS OF SUPPLIED PRODUCTS.



906 JAMES STREET
 ADRIAN, MI 49221
 517-265-6194

WWW.ADRIANSTEEL.COM

⚠ CAUTION ⚠

WHEN INSTALLING EQUIPMENT IN OR ON VEHICLES CHECK FOR FUEL TANKS, FUEL LINES, CONTROL LINES AND ELECTRICAL WIRING BEFORE DRILLING! ALWAYS USE DRILL BITS WITH INTEGRAL STOPS WHENEVER POSSIBLE!

DRAWN BY
 B. HENSON

DATE DRAWN
 12/17/10

ECN NUMBER
 14423

ECN DATE
 1/5/2012

PART WEIGHT
 0.00 LBS.

REV. LEVEL
 C

PART NUMBER

28843-0