

ITEM	PART #	DESCRIPTION	QTY
1	BRK14EPS	ACC BRKT KIT, END PANEL	2
2	WRH5	SPOOL HDLR 6" 5-BAR	1

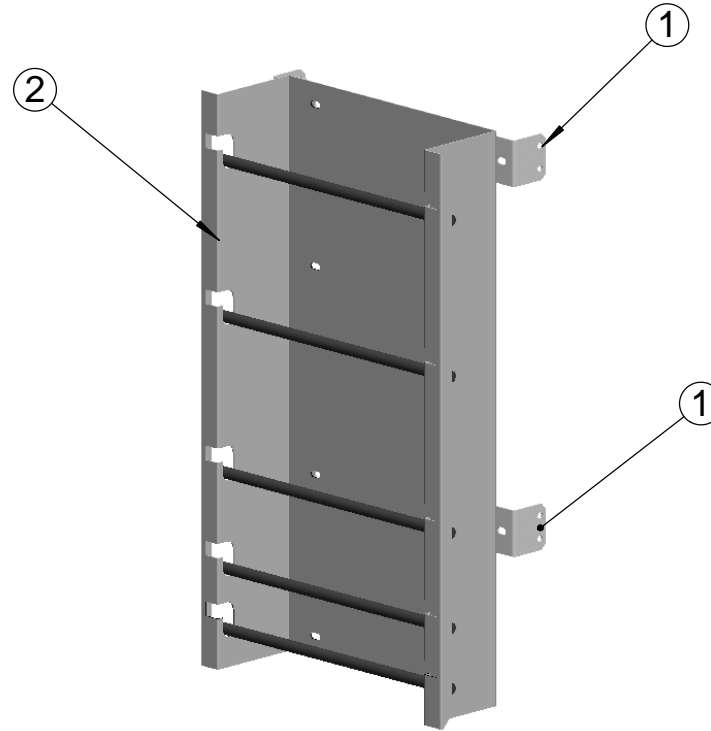

PRINTED DOCUMENT IS UNCONTROLLED



**ADRIAN STEEL®**

VAN AND PICKUP EQUIPMENT  
 CARGO MANAGEMENT SOLUTIONS FOR COMMERCIAL VEHICLES  
 906 James St., Adrian, Michigan 49221  
 517.265.6194  
 www.adriansteel.com

Customer:

**WRH5  
 WITH AD BRACKETS**

Drawn By:

**BDS**

Date:

**10/04/2013**

ECN No:

**15856**

PKG No:

**46106**

Package Weight:

**12.70**

CG Horizontal & Vertical:

HCG=**6.00** VCG=**12.00**

Sheet:

**1 of 1**

Rev.:

**A**

**CAUTION:**  
 DRILL THRU FLOOR WITH CARE!  
 WATCH FOR GAS TANK, CONTROL  
 LINES, & ELECTRICAL WIRING.



**AD Series Accessory  
Mounting Kit Assembly/Installation Instructions**

The following page(s) cover the installation of various Rail Adapter Kits used on the new ASCO AD Series Shelving Kits.

- RKFSVLD, RD "Rail Sys, AD Series, Left Hand Door"
- RKFSVLRWB "Rail Sys, AD Series, Long Wheel Base"
- RKFSVXLWB "Rail Sys, AD Series, Xtra-Long Wheel Base"

**BRK1AEP3 "Accessory Bracket Kit, End Panel"**

- WU1: 43 "Catalog File, 3-Shell, 12 DX34" Hx6"W"  
(Requires (2) RKABRK2 per install)

**BEFORE YOU START!**

ALL FASTENERS USED IN THE ASSEMBLY AND INSTALLATION OF THIS PRODUCT SHOULD BE TIGHTENED TO THE SPECIFIED TORQUE. THE USE OF NON-STANDARD FASTENERS AND/OR DEVIATING FROM THE FASTENERS SPECIFIED IN THE INSTRUCTION (S) MAY VOID YOUR PRODUCT WARRANTY!

**YOU WILL NEED THE FOLLOWING TOOLS IN ORDER TO COMPLETE THIS JOB.**

- 7/16" End Wrench, Ratchet w/7/16" Socket,  
Phillips Screwdriver, Torque Wrench

Attach both End Panel Mounting Weldments (BKABRK2) to the 43 with fasteners supplied with the kit. Note, the upper weldment will use existing holes, while the lower weldment will require marking and drilling (2) 9/32" dia. thru mounting holes in the side wall of the unit. Then attach assembly to the AD Shelf End Panel in desired location. See photo's below for details on mounting weldments to shelf end panel.



**YOUR INSTALLATION IS NOW COMPLETE! STOW THIS COPY IN THE VEHICLE FOR FUTURE REFERENCE!**



**AD Series Accessory  
Mounting Kit Assembly/Installation Instructions**



- WU1: ACT3 "Aerosol Can Tray, 3-Hole"  
ACT4 "Aerosol Can Tray, 4-Hole"  
(Requires (2) RKABRK2 per install)

**BEFORE YOU START!**

ALL FASTENERS USED IN THE ASSEMBLY AND INSTALLATION OF THIS PRODUCT SHOULD BE TIGHTENED TO THE SPECIFIED TORQUE. THE USE OF NON-STANDARD FASTENERS AND/OR DEVIATING FROM THE FASTENERS SPECIFIED IN THE INSTRUCTION (S) MAY VOID YOUR PRODUCT WARRANTY!

**YOU WILL NEED THE FOLLOWING TOOLS IN ORDER TO COMPLETE THIS JOB.**

- 7/16" End Wrench, Ratchet w/7/16" Socket,  
Phillips Screwdriver, Torque Wrench

Attach both End Panel Mounting Weldments (BKABRK2) to the ACT3 & ACT4 with fasteners supplied with the WRHS kit. When attaching accessory to the mounting weldments use existing holes in the accessory, aligning them with holes in the mounting weldments. Then attach assembly to the AD Shelf End Panel in desired location. See photo's below for details on mounting weldments to shelf end panel.



**YOUR INSTALLATION IS NOW COMPLETE! STOW THIS COPY IN THE VEHICLE FOR FUTURE REFERENCE!**

**BRK1AEP3 "Accessory Bracket Kit, End Panel"**

WUJ: AGSCH2 "Suction Cup Holder"

**BEFORE YOU START**

ALL FASTENERS USED IN THE ASSEMBLY AND INSTALLATION OF THIS PRODUCT SHOULD BE TIGHTENED TO THE SPECIFIED TORQUE. THE USE OF NON-STANDARD FASTENERS AND/OR DEVIATING FROM THE FASTENERS SPECIFIED IN THE INSTRUCTION (S) MAY VOID YOUR PRODUCT WARRANTY!

**YOU WILL NEED THE FOLLOWING TOOLS IN ORDER TO COMPLETE THIS JOB.**

*7/16" End Wrench, Ratchet w/7/16" Socket  
Phillips Screwdriver, Torque Wrench*



**AGSCH2**

Attach one End Panel Mounting Weldment (BKABRK2) to the AGSCH2 with fasteners supplied with the accessory kit. When attaching AGSCH2 to mounting weldment use the upper holes in the AGSCH2, aligning them with holes in the mounting weldment. Then attach assembly to the AD Shelf End Panel in desired location. See photo's below for details on mounting weldment to shelf end panel.



**YOUR INSTALLATION IS NOW COMPLETE! STOW THIS COPY IN THE VEHICLE FOR FUTURE REFERENCE!**

**BRK1AEP3 "Accessory Bracket Kit, End Panel"**

WUJ: BH4 "Binder Holder, 4-Pocket"  
CBS "Literature Holder, 5-Slot"  
(Requires (2) RKABRK2 per install)

**BEFORE YOU START**

ALL FASTENERS USED IN THE ASSEMBLY AND INSTALLATION OF THIS PRODUCT SHOULD BE TIGHTENED TO THE SPECIFIED TORQUE. THE USE OF NON-STANDARD FASTENERS AND/OR DEVIATING FROM THE FASTENERS SPECIFIED IN THE INSTRUCTION (S) MAY VOID YOUR PRODUCT WARRANTY!

**YOU WILL NEED THE FOLLOWING TOOLS IN ORDER TO COMPLETE THIS JOB.**

*7/16" End Wrench, Ratchet w/7/16" Socket  
Phillips Screwdriver, Torque Wrench*

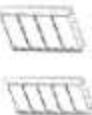

**BH4**

**CBS**

Attach both End Panel Mounting Weldments (BKABRK2) to the WRH5 with fasteners supplied with the WRH5 kit. When attaching WRH5 to mounting weldments use existing holes in the WRH5 aligning them with holes in the mounting weldments. Then attach assembly to the AD Shelf End Panel in desired location. See photo's below for details on mounting weldments to shelf end panel.



**YOUR INSTALLATION IS NOW COMPLETE! STOW THIS COPY IN THE VEHICLE FOR FUTURE REFERENCE!**

**BRK1AEP5 "Accessory Bracket Kit, End Panel"**

- PA7 "Reflector Flare Kit, 5" (Requires (2) PKA8RK2 per install)
- PA8 "Fire Ext. IAL10BC 2.5# (Requires (2) PKA8RK2 per install)
- PA9 "First Aid Tray, 11"x4.5"x3.125"
- PA10 "Practice Holder"
- PA11 "Cabinet File Box, 3.75"Dx12"Wx10"H"

**BEFORE YOU START!**

ALL FASTENERS USED IN THE ASSEMBLY AND INSTALLATION OF THIS PRODUCT SHOULD BE TIGHTENED TO THE SPECIFIED TORQUE. THE USE OF NON-STANDARD FASTENERS AND/OR DEVIATING FROM THE FASTENERS SPECIFIED IN THE INSTRUCTION (S) MAY VOID YOUR PRODUCT WARRANTY.

**YOU WILL NEED THE FOLLOWING TOOLS IN ORDER TO COMPLETE THIS JOB.**

**7/16" End Wrench, Ratchet w/7/16" Socket,**
**Phillips Screwdriver, Torque Wrench**

Attach both End Panel Mounting Weldments (DW48SR-2) to the PA7 & PA8 with fasteners supplied with the accessory kit. Please note that only one mounting weldment is required when attaching the PA9, PA10, & PA11 to the mounting weldment via existing holes in the accessory, aligning them with holes in the mounting weldments. Then attach assembly to the AD Shell End Panel in desired location. See photo's below for details on mounting weldments to shell end panel.

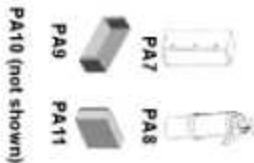

**YOUR INSTALLATION IS NOW COMPLETE! SHOW THIS COPY IN THE VEHICLE FOR FUTURE REFERENCE!**

**BRK1AEP5 "Accessory Bracket Kit, End Panel"**

- TH30 "Tank Holder, 30# Sgl (Requires (2) PKA8RK2 per install)
- TH50 "Tank Holder, 50# Sgl (Requires (2) PKA8RK2 per install)

**BEFORE YOU START!**

ALL FASTENERS USED IN THE ASSEMBLY AND INSTALLATION OF THIS PRODUCT SHOULD BE TIGHTENED TO THE SPECIFIED TORQUE. THE USE OF NON-STANDARD FASTENERS AND/OR DEVIATING FROM THE FASTENERS SPECIFIED IN THE INSTRUCTION (S) MAY VOID YOUR PRODUCT WARRANTY.

**YOU WILL NEED THE FOLLOWING TOOLS IN ORDER TO COMPLETE THIS JOB.**

**7/16" End Wrench, Ratchet w/7/16" Socket,**
**Phillips Screwdriver, Torque Wrench**

Attach both End Panel Mounting Weldments (DW48SR-2) to the PA7 & PA8 with fasteners supplied with the accessory kit. Please note that only one mounting weldment is required when attaching the PA9, PA10, & PA11 to the mounting weldment via existing holes in the accessory, aligning them with holes in the mounting weldments. Then attach assembly to the AD Shell End Panel in desired location. See photo's below for details on mounting weldments to shell end panel.



**YOUR INSTALLATION IS NOW COMPLETE! SHOW THIS COPY IN THE VEHICLE FOR FUTURE REFERENCE!**

**BRK1AEP5 "Accessory Bracket Kit, End Panel"**

WUJ:

- UH10 "Utility Hook, 1", Single"
- UH25 "Utility Hook, 2.5", Single"
- UH50 "Utility Hook, 5", Single"
- TA1 "Four Hook Bar"
- TA2 "Hard Hat Holder"

**BEFORE YOU START!**

ALL FASTENERS USED IN THE ASSEMBLY AND INSTALLATION OF THIS PRODUCT SHOULD BE TIGHTENED TO THE SPECIFIED TORQUE. THE USE OF NON-STANDARD FASTENERS AND/OR DEVIATING FROM THE FASTENERS SPECIFIED IN THE INSTRUCTION (S) MAY VOID YOUR PRODUCT WARRANTY!

**YOU WILL NEED THE FOLLOWING TOOLS IN ORDER TO COMPLETE THIS JOB.**

- 7/16" End Wrench, Ratchet w/7/16" Socket,
- Phillips Screwdriver, Torque Wrench

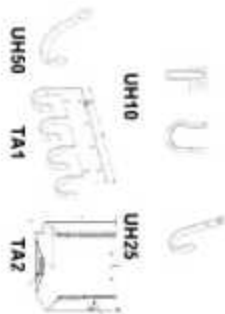

Attach one End Panel Mounting Weldments (BKA5BRK1) to the accessory with fasteners supplied with the accessory kit. When attaching accessory to mounting weldment use existing holes in the accessory, aligning them with holes in the mounting weldments. Then attach assembly to the AD Shelf End Panel in desired location. See photo's below for details on mounting weldments to shelf end panel.



**YOUR INSTALLATION IS NOW COMPLETE! STOW THIS COPY IN THE VEHICLE FOR FUTURE REFERENCE**

**BRK1AEP5 "Accessory Bracket Kit, End Panel"**

WUJ:

- WRH5 "Spool Holder, 6", 5-Bar"  
(Requires (2) BKA5BRK2 per install)

**BEFORE YOU START!**

ALL FASTENERS USED IN THE ASSEMBLY AND INSTALLATION OF THIS PRODUCT SHOULD BE TIGHTENED TO THE SPECIFIED TORQUE. THE USE OF NON-STANDARD FASTENERS AND/OR DEVIATING FROM THE FASTENERS SPECIFIED IN THE INSTRUCTION (S) MAY VOID YOUR PRODUCT WARRANTY!

**YOU WILL NEED THE FOLLOWING TOOLS IN ORDER TO COMPLETE THIS JOB.**

- 9/16" End Wrench, Ratchet w/9/16" socket, Torque Wrench



Attach both End Panel Mounting Weldments (BKA5BRK2) to the WRH5 with fasteners supplied with the WRH5 kit. When attaching WRH5 to mounting weldments use existing holes in the WRH5 aligning them with holes in the mounting weldments. Then attach assembly to the AD Shelf End Panel in desired location. See photo's below for details on mounting weldments to shelf end panel.



**YOUR INSTALLATION IS NOW COMPLETE! STOW THIS COPY IN THE VEHICLE FOR FUTURE REFERENCE!**



**ADRIAN STEEL®**

Cargo Management Solutions for Commercial Vehicles

## **SPOOL HOLDER 6" 5-BAR**

*PRODUCT WEIGHT*

**12 LBS**

*WIDTH X DEPTH X HEIGHT*

**14.0" x 4.0" x 25.0"**

*CAPACITY*

**6" DIA Spool**

*COLOR*

**GRAY**

*CATALOG NUMBER*

**WRH5**

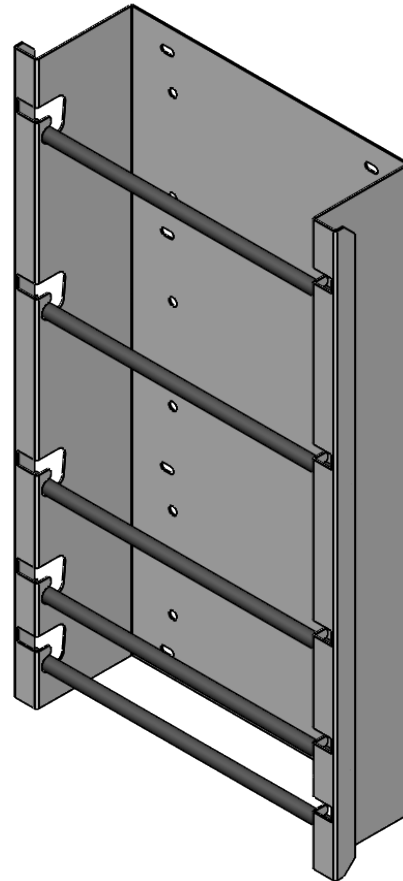

### **PRODUCT FEATURES**

This holder stores up to 5 spools, ranging from 6 inches to 2 inches in diameter, keeping them secure and organized in any vehicle. Whether for work or travel, it ensures easy access without clutter or tangles. Securely mounts to standard van shelving and next generation shelving end panels, ensuring smooth rotation and tangle-free dispensing. Built with durable materials, it withstands the rigors of mobile workspaces, making it perfect for electricians, contractors, and makers on the move.