



Rear Roller Assist Bar, White, Low Roof, Sprinter



PRODUCT WEIGHT
9.9 LBS

WIDTH x DEPTH x HEIGHT
69" x 25" x 4.3"

CAPACITY
250 LBS

COLOR
WHITE

CATALOG NUMBER
RRBSPW

PRODUCT FEATURES

Aluminum rear roller assist kit for Mercedes Sprinter, Low Roof PROFILE™ HD Utility Racks. Works with all upright kits and conduit kits. Does NOT work on high roof Mercedes Sprinter. Does NOT work OEM roof rails or Adrian Steel supplied Mercedes Sprinter specific roof rails.

Please refer to OEM specific mounting kit and rail kit for additional information on compatible accessories.

SEE PAGE 2 FOR APPLICATION NOTES AND ACCESSORIES, OTHER PRODUCTS THAT WORK WITH THIS UNIT.

PAGE 1 of 2

The information contained in this document is the sole property of ADRIAN STEEL COMPANY. ADRIAN STEEL COMPANY retains the right to modify and/or change the product of its design at any time without prior notification.



CATALOG NUMBER RRBSPW

PRODUCT APPLICATION

This product is for Mercedes Sprinter, Low Roof PROFILE™ HD Utility Racks. Does NOT work on Mercedes Sprinter, High Roof vehicles. Does NOT work on high roof Mercedes Sprinter. Does NOT work OEM roof rails or Adrian Steel supplied Mercedes Sprinter specific roof rails.

ACCESSORIES THAT WILL WORK WITH THIS PRODUCT

<i>CATALOG NUMBER</i>	<i>DESCRIPTION</i>
2BARW	2-Crossbar Kit, 68”, White, Full Size Van
SPMBK4W	Mounting Bracket Kit, 4-Pack, White, Sprinter

<i>INSTR. NUMBER</i> : 64344	<i>PG:</i> 1	<i>REV:</i> D	<i>ITEM NO.</i>	<i>PART NUMBER</i>	<i>DESCRIPTION</i>	
			1	64174	REAR ROLLER,BAR ASSM,62"	1
<i>PART NUMBER</i> : RRBFTW			2	64158-W	REAR ROLLER,DS WELD,FT,W	1
<i>PART DESC.</i> : UTILITY,REAR ROLLER,FT,W			3	64159-W	REAR ROLLER,PS WELD,FT,W	1

NOTE: THIS INSTRUCTION IS VALID FOR ALL "RRB" REAR ROLLER KITS:

- RRBFTW (SHOWN)
 (& FORD TRANSIT SHIP THRU CONFIGURATION)
- RRBNVW
- RRBSPW
- RRBSPRW

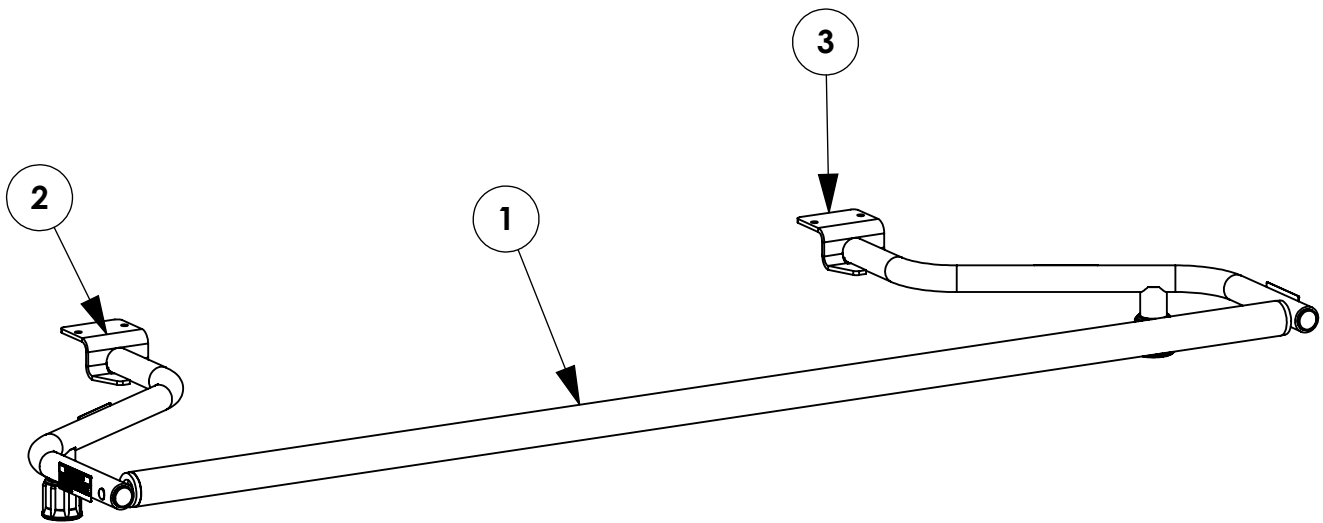

GET TO KNOW THE VEHICLE - AT THE BEGINNING OF ANY INSTALLATION, CHECK THE LOCATION OF THE FUEL TANK, FUEL LINES, BRAKE LINES, HIGH VOLTAGE BATTERIES AND WIRING HARNESSSES TO AVOID INJURY OR PROPERTY DAMAGE FROM TOOL CONTACT.

SEAL ALL EXTERIOR HOLES - ALL INSTALLATION HOLES SHOULD BE SEALED WITH BUTYL TAPE OR SILICON TO PREVENT WATER AND EXHAUST GASES FROM ENTERING THE VEHICLE.

CONTROL DRILL DEPTH - TO AVOID DAMAGE TO THE VEHICLE, USE A DRILL STOP OR CLEARED STEP BIT WHEN DRILLING INSTALLATION HOLES.

ALWAYS ADD PRIMER - WHEN ADDING INSTALLATION HOLES BE SURE TO USE A SELF-ETCHING PRIMER TO PREVENT CORROSION, FASTENER FAILURE AND INJURY.

MOUNTING POINTS MUST HAVE METAL-TO-METAL CONTACT - USE PROVIDED MOUNTING SPACERS TO ACCOMMODATE FOR VEHICLE FEATURES, CARPET OR SUBFLOORS.

PROVIDE CLEARANCE FOR SPACERS - IF THE INSTALLATION VEHICLE CONTAINS A CARPET OR SUBFLOOR, USE A 1-3/16" DIAMETER CARPET CUTTER (P/N: 31183-0) AT ALL MOUNTING LOCATIONS TO OPEN UP ROOM FOR SPACERS.

CHECK SPACER ORIENTATION - BE SURE THAT THE INDENT IN THE SPACER COVERS THE PLUSNUT HEAD; THIS ENSURES THE MOST METAL-TO-METAL CONTACT AND REDUCES VIBRATION.

PLUSNUT INSTALLATION - A PLUSNUT GUN IS RECOMMENDED FOR PLUSNUT INSTALLATION FOR ITS PRODUCTION SPEED. HOWEVER, A PLUSNUT SETTING TOOL CAN ALSO BE USED (P/N: 22200-0).

THRU-BOLT CLEARANCE - WHEN USING A THRU-BOLT AT ANY MOUNTING LOCATION, BE SURE THAT YOUR HOLE HAS 1/16" CLEARANCE.

FASTENERS USED

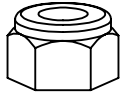

FAS0248
5/16-18 SS
NLK HEX NUT
QTY: 4



FAS0552
5/16 SS
FLAT WASHER
QTY: 4

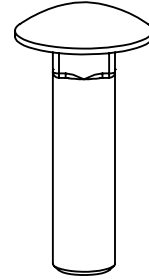

FAS0812
5/16-18X1.25 SS
CRG BOLT
QTY: 4

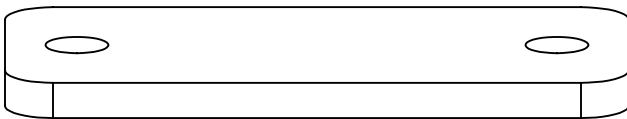

64831
SPACER,
REAR ROLLER
QTY: 2

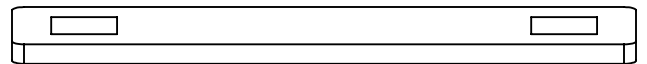

63934
NOLT PLATE,
REAR ROLLER
QTY: 2

BEGIN ASSEMBLY

STEP 1 - ATTACH ROLLER ARMS TO CROSSBOW

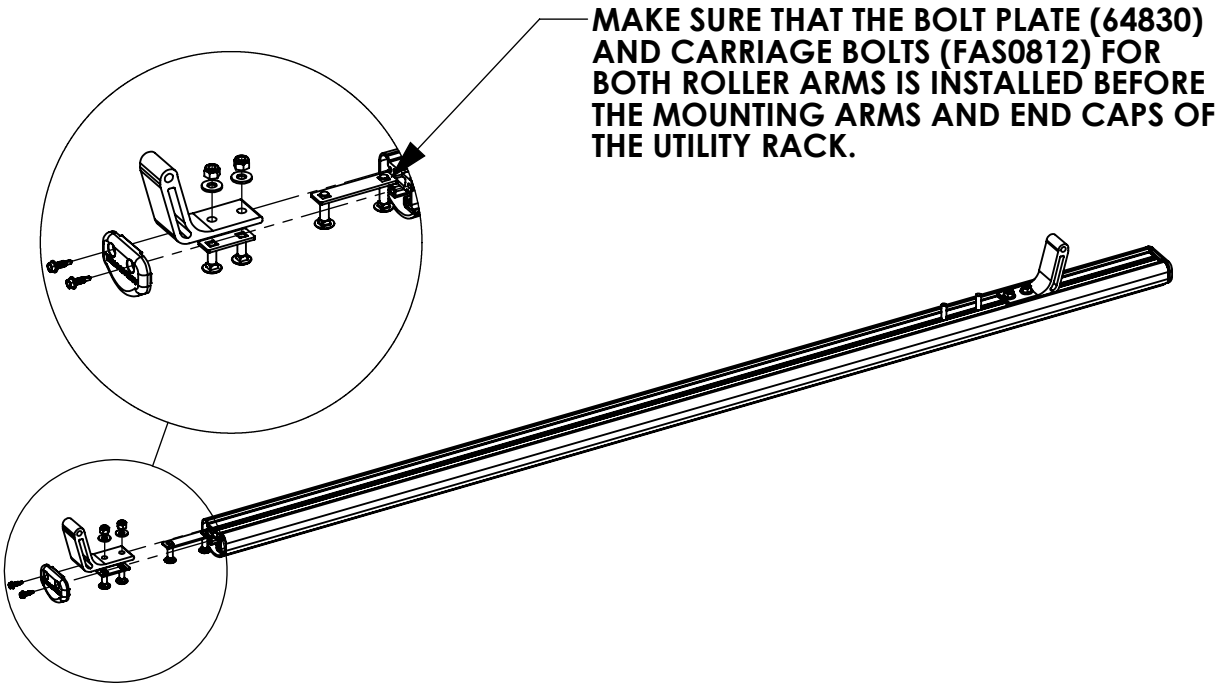

STEP 2 - ADD ROLLER BAR & SECURE

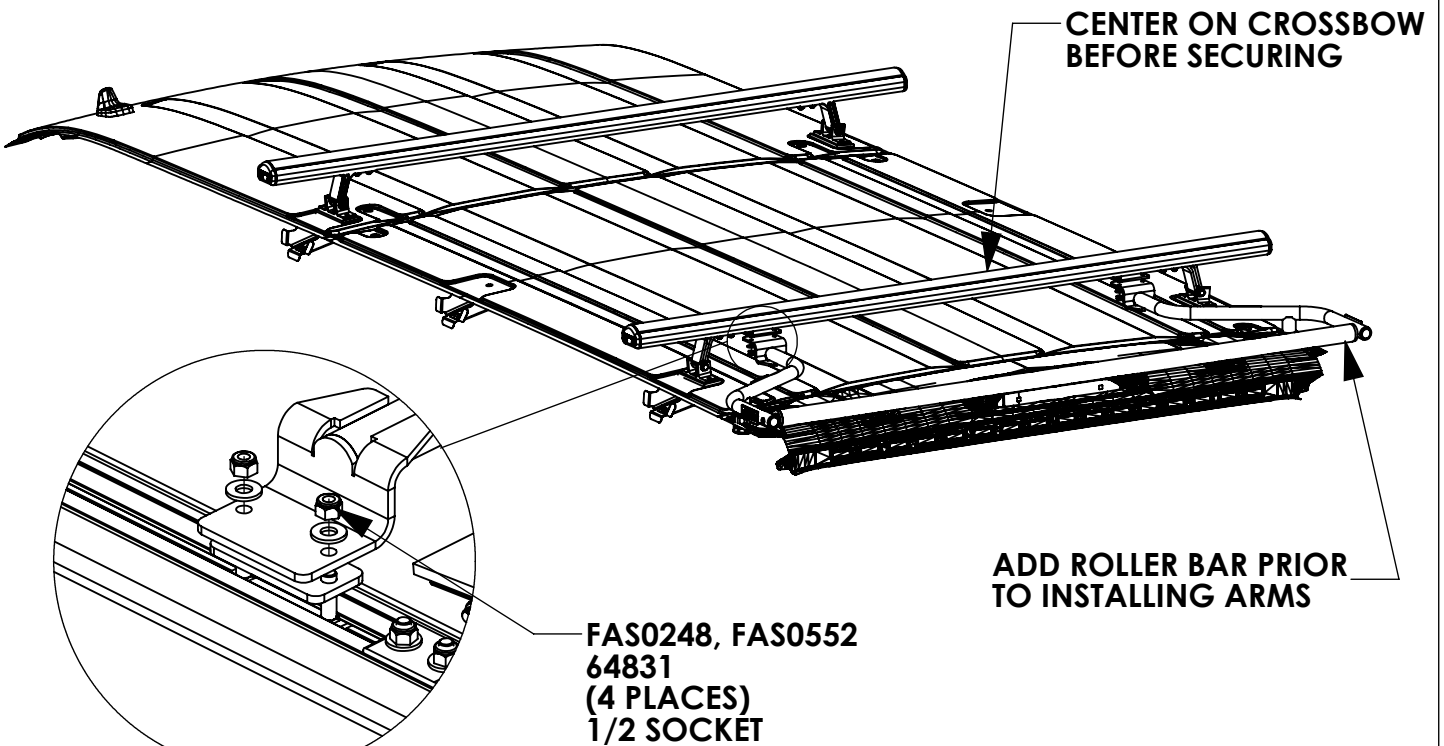

NOTE: DETAIL VIEW IS FROM BOTTOM OF RACK

NOTE FOR RRBSPRW - MERCEDES SPRINTER WITH OEM ROOF RAILS

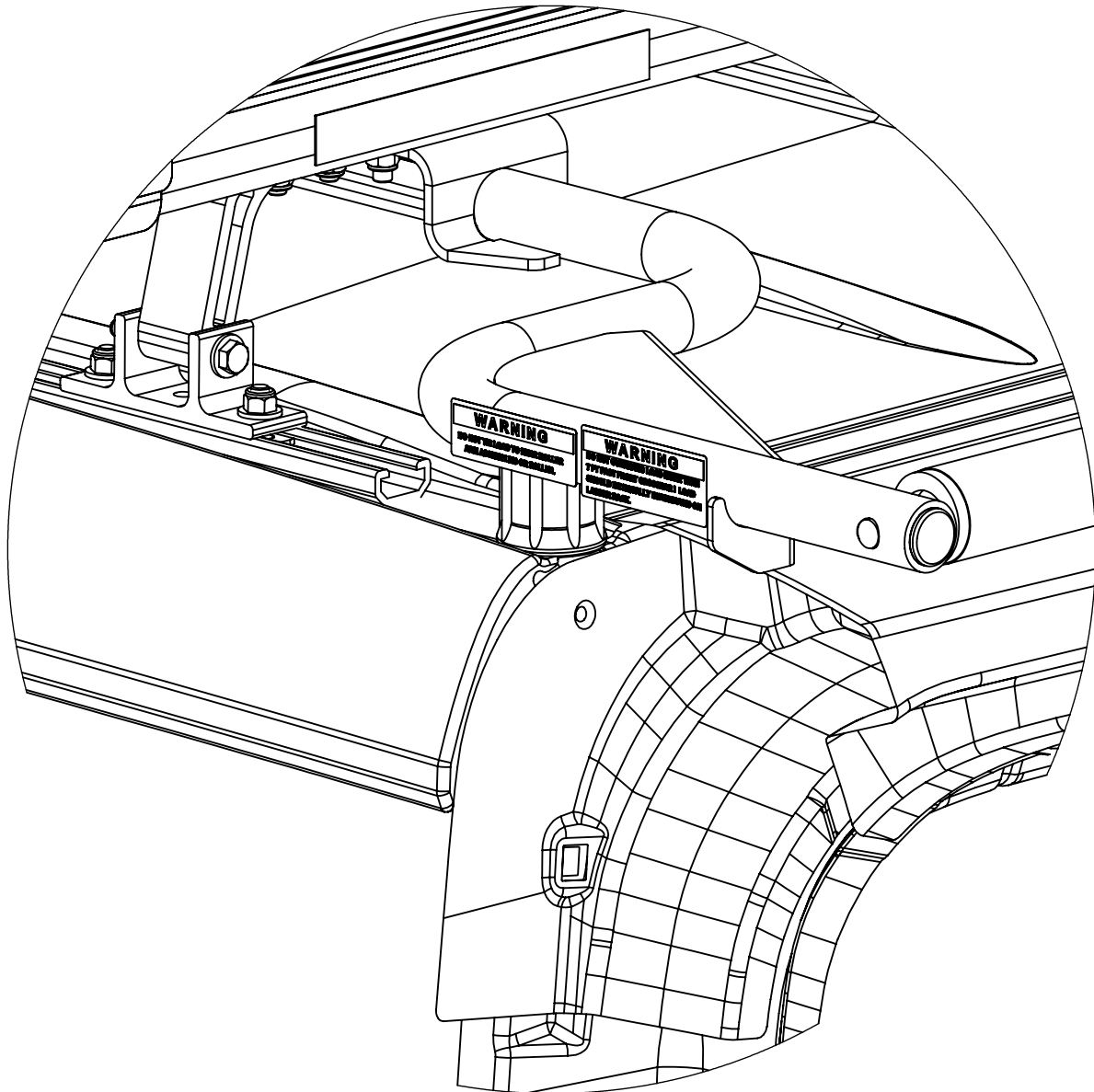

WHEN INSTALLING RRBSPRW ON MERCEDES OEM ROOF RAILS, ENSURE REAR CROSSBOW IS POSITIONED ON THE RAILS SO THE RUBBER SUPPORT IS POSITIONED AS SHOWN



Mounting Bracket Kit, 2-Pack, White, Sprinter

PRODUCT WEIGHT
2 LBS

HEIGHT OFF ROOF

SEE TABLE BELOW

CAPACITY
**REFER TO OEM'S
RECOMMENDED LOAD
RATING**

COLOR

WHITE

CATALOG NUMBER

SPMBK2W

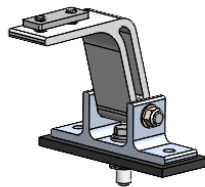
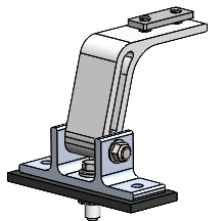

PRODUCT FEATURES

Mercedes Sprinter aluminum mounting bracket kit for the PROFILE™ HD Utility Racks to add additional crossbows to 2-Bar rack. Mounting kit works for low roof vehicles without the OEM roof rail option. Can be mounted to any OEM mounting locations to best fit customer's product.

Utility racks are not recommended for high roof vehicles!

Does not work with grip lock or drop down style racks.

SEE PAGE 2 FOR APPLICATION NOTES AND ACCESSORIES, OTHER PRODUCTS THAT WORK WITH THIS UNIT.

PAGE 1 of 2

The information contained in this document is the sole property of ADRIAN STEEL COMPANY. ADRIAN STEEL COMPANY retains the right to modify and/or change the product of its design at any time without prior notification.



CATALOG NUMBER SPMBK2W

PRODUCT APPLICATION

This product is designed to be installed on Mercedes Sprinter vans without OEM roof rail option. HD Utility Racks are not recommended for high roof vehicles!

ACCESSORIES THAT WILL WORK WITH THIS PRODUCT

CATALOG NUMBER	DESCRIPTION	CATALOG NUMBER	DESCRIPTION
SPMBK4W	Mounting Bracket Kit, 4-Pack, White, Sprinter	4UPK4B	4" Upright Kit, 4-Pack, Black
2BARW	2-Crossbar Kit, 68", White, Full Size Van	4UPK2B	4" Upright Kit, 2-Pack, Black
1BARW	Single Crossbar Kit, 68", White, Full Size Van	6UPK4B	6" Upright Kit, 4-Pack, Black
RRBSPW*	Rear Roller Assist Bar, White, Sprinter	6UPK2B	6" Upright Kit, 2-Pack, Black
70-1NGLR	4" End Cap for PVC Conduit	9UPK4B	9" Upright Kit, 4-Pack, Black
70-2NGLR	6" End Cap for PVC Conduit	9UPK2B	9" Upright Kit, 2-Pack, Black
80-1NGLR	Conduit Kit, 10w x 6h x 126d, Multiple Vehicles	RSK1B	Single Ratchet Upright Kit, 9"
80-2NGLR	Conduit Kit, 10w x 6h x 150d, Multiple Vehicles	ULSKB	Single Ladder Stop Kit

*Does not work with high roof vehicles!

LADDER RACK HEIGHTS MEASURED FROM ROOF OF VEHICLE

CONFIGURATION	RACK HEIGHT LOW / HIGH ROOF
Base Rack	4.3" / 4.9"
Base + Ladder Stop	9.8" / 10.4"
Base + 4" Uprights	7.8" / 8.4"
Base + 6" Uprights	9.8" / 10.4"
Base + 9"/Ratchet Uprights	12.8" / 13.4"
Base + 4" PVC Conduit Kit	8.7" / 9.3"
Base + 6" PVC Conduit Kit	10.7" / 11.3"
Base + Aluminum Box Conduit Kit	10.8" / 11.4"

INSTR. NUMBER : 63658	PG: 1	REV: D	ITEM NO.	PART NUMBER	DESCRIPTION	SPMBK4W	SPMBK2W
PART NUMBER : SPMBK			1	68202-W	PROFILE, MOUNTING ARM, W	4	2
			2	63852-W	UTILITY, MOUNTING BRKT, W	4	2
PART DESC. : UTILITY,MNT BKT KT,SP			3	47106	GASKET,FOOT,MR TRANS L/R	4	2
			4	64930	UTILITY, TRANS CON SPACER	2	-

NOTE: THIS INSTRUCTION IS VALID FOR THE FOLLOWING KITS:

**-PART NUMBERS WITH "-W" SUFFIX ARE PAINTED WHITE
- FOR BLACK MOUNTING KITS, REPLACE "-W" PARTS WITH "-B" PARTS**

- SPMBK4W
- SPMBK2W
- SPMBK4B
- SPMBK2B

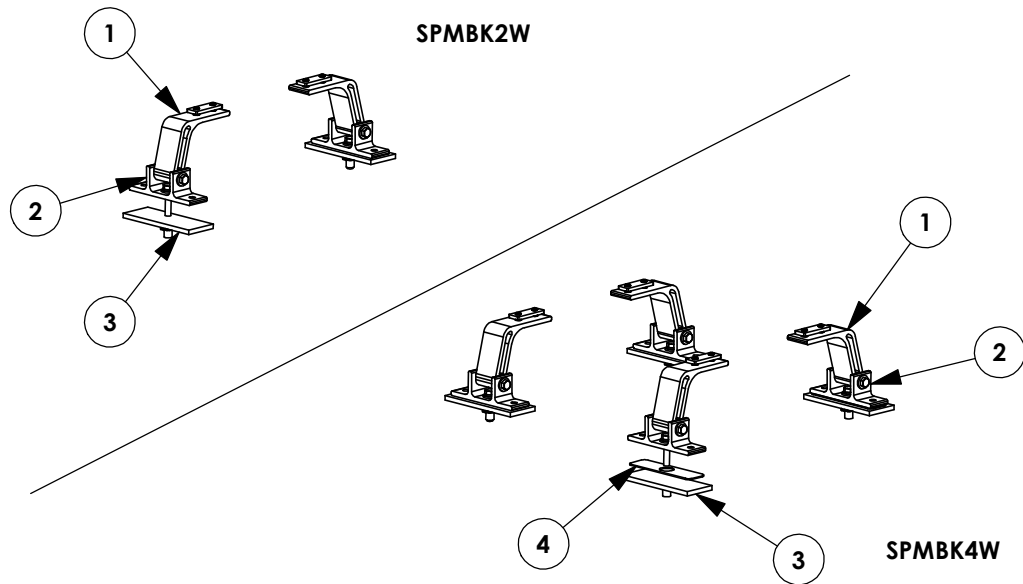

GET TO KNOW THE VEHICLE - AT THE BEGINNING OF ANY INSTALLATION, CHECK THE LOCATION OF THE FUEL TANK, FUEL LINES, BRAKE LINES, HIGH VOLTAGE BATTERIES AND WIRING HARNESSES TO AVOID INJURY OR PROPERTY DAMAGE FROM TOOL CONTACT.

SEAL ALL EXTERIOR HOLES - ALL INSTALLATION HOLES SHOULD BE SEALED WITH BUTYL TAPE OR SILICON TO PREVENT WATER AND EXHAUST GASES FROM ENTERING THE VEHICLE.

CONTROL DRILL DEPTH - TO AVOID DAMAGE TO THE VEHICLE, USE A DRILL STOP OR CLEARED STEP BIT WHEN DRILLING INSTALLATION HOLES.

ALWAYS ADD PRIMER - WHEN ADDING INSTALLATION HOLES BE SURE TO USE A SELF-ETCHING PRIMER TO PREVENT CORROSION, FASTENER FAILURE AND INJURY.

MOUNTING POINTS MUST HAVE METAL-TO-METAL CONTACT - USE PROVIDED MOUNTING SPACERS TO ACCOMMODATE FOR VEHICLE FEATURES, CARPET OR SUBFLOORS.

PROVIDE CLEARANCE FOR SPACERS - IF THE INSTALLATION VEHICLE CONTAINS A CARPET OR SUBFLOOR, USE A 1-3/16" DIAMETER CARPET CUTTER (P/N: 31183-0) AT ALL MOUNTING LOCATIONS TO OPEN UP ROOM FOR SPACERS.

CHECK SPACER ORIENTATION - BE SURE THAT THE INDENT IN THE SPACER COVERS THE PLUSNUT HEAD; THIS ENSURES THE MOST METAL-TO-METAL CONTACT AND REDUCES VIBRATION.

PLUSNUT INSTALLATION - A PLUSNUT GUN IS RECOMMENDED FOR PLUSNUT INSTALLATION FOR ITS PRODUCTION SPEED. HOWEVER, A PLUSNUT SETTING TOOL CAN ALSO BE USED (P/N: 22200-0).

THRU-BOLT CLEARANCE - WHEN USING A THRU-BOLT AT ANY MOUNTING LOCATION, BE SURE THAT YOUR HOLE HAS 1/16" CLEARANCE.

FASTENERS USED

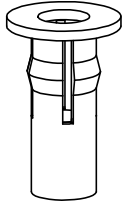

FAS0091
5/16-18 PB
PLUSNUT
QTY: 4

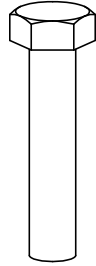

FAS0242
5/16-18 X 1.5 SS
HH SCREW
QTY: 4

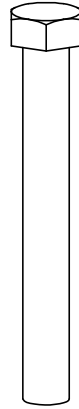

FAS0243
5/16-18 X 2.5 SS
HH SCREW
QTY: 4



FAS0552
5/16 SS
FLAT WASHER
QTY: 8



FAS0588
5/16 SS
SPLIT WASHER
QTY: 4



FAS0857
5/16 SS, CS
LCK EXT WASHER
QTY: 8



FAS0858
5/16-18 X .625 SS
FHH SCREW
QTY: 8

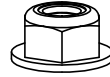

FAS0861
5/16-18 SS
HFLNG NUT
QTY: 4

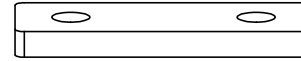

68042
PROFILE FOOT
MTG PLATE
QTY: 4

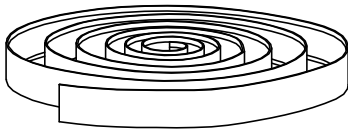

05586-0
BUTYL TAPE
T224 1FT ROLL
QTY: 1

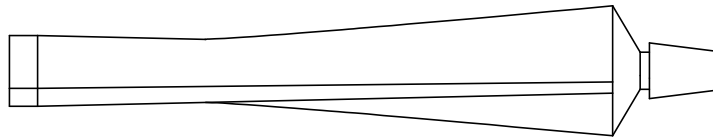

26618-0
SILICONE
1 OZ TUBE
QTY: 1

INTENTIONALLY LEFT BLANK

STEP 1 - ASSEMBLE MOUNTING ARMS TO CROSSBOW

Step 1.1
LOOSELY INSTALL
UNTIL AFTER STEP 4
(2) FAS0857, (2)
FAS0858 & 68042
(2 PLACES PER
CROSSBOW)
3/16" ALLEN

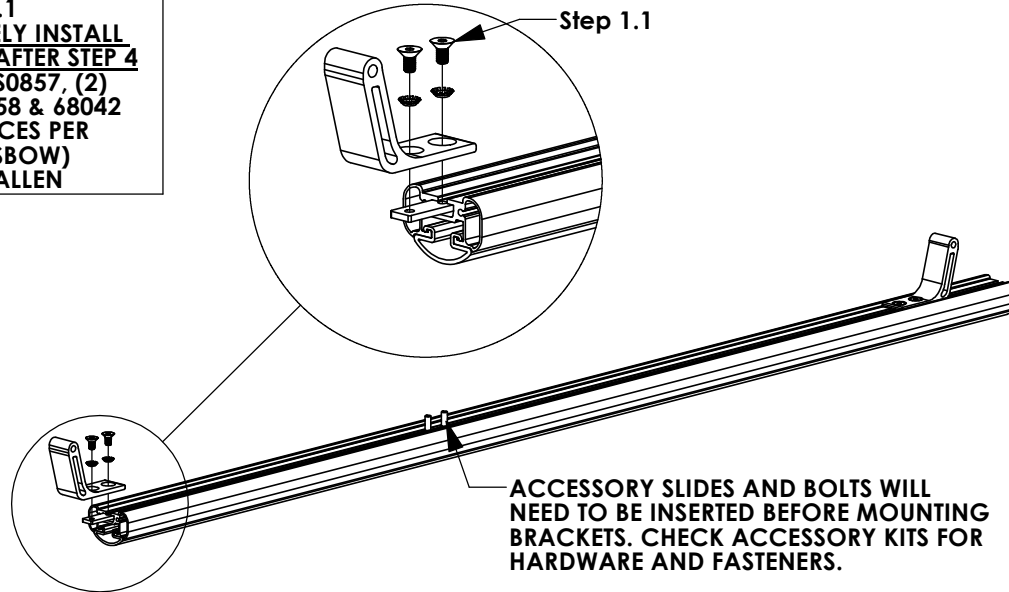

STEP 2 - INSTALL MOUNTING BRACKETS TO VEHICLE ROOF

Step 2.1
FAS0242, FAS0588,
FAS0552, FAS091
(2 PLACES PER CROSSBOW)
1/2" SOCKET
5/16"-18 PLUSNUT GUN

Step 2.2
OPEN UP OEM HOLE
WITH 1/2" DRILL BIT. USE
A DRILL STOP TO PREVENT
DAMAGE TO MATERIAL
UNDER HOLE

STEP 2.3:
64930 SPACER ONLY USED
ON REAR
CROSSBOW

POKE FASTENERS THRU
FOAM PAD

APPLY SILICONE AND BUTYL
TAPE TO
BOLT BEFORE TIGHTENING

CROSSBOW POSITIONING NOTES:
 REAR CROSSBOW - REAR OEM MOUNTING LOCATION
 FRONT CROSSBOW - POSITION TO BEST FIT END USER'S PRODUCT

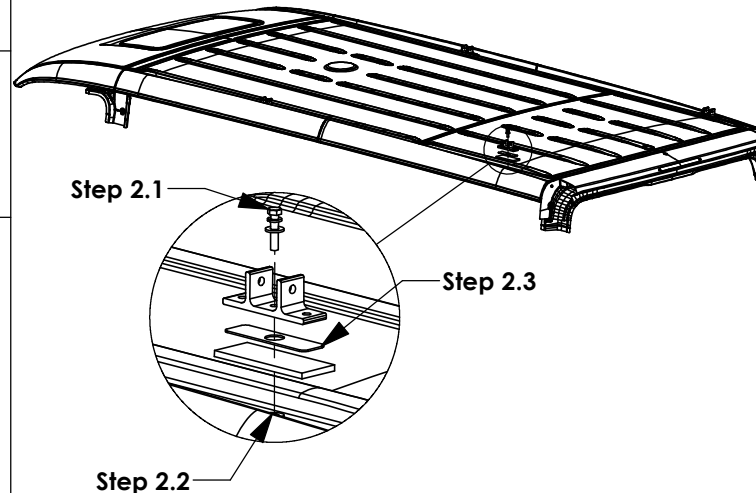

STEP 3 - ATTACH CROSSBOW ASSEMBLY TO MOUNTING BRACKETS

Step 3.1
FAS0243, FAS0522,
FAS0861
(2 PLACES PER
CROSSBOW)
1/2" SOCKET
1/2" WRENCH

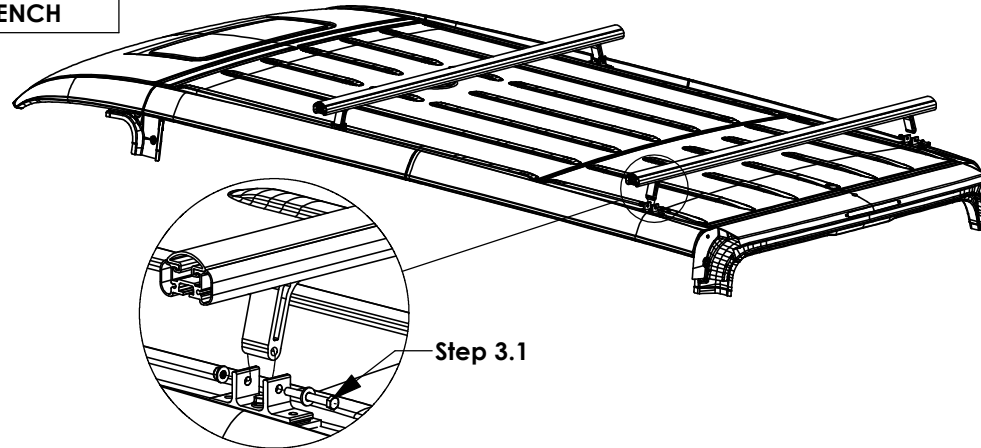

STEP 4 - SECURE CROSSBOW

Step 4.1
CENTER CROSSBOW AND
SECURE MOUNTING
BRACKETS
(4 PLACES PER
CROSSBOW)
3/16" ALLEN

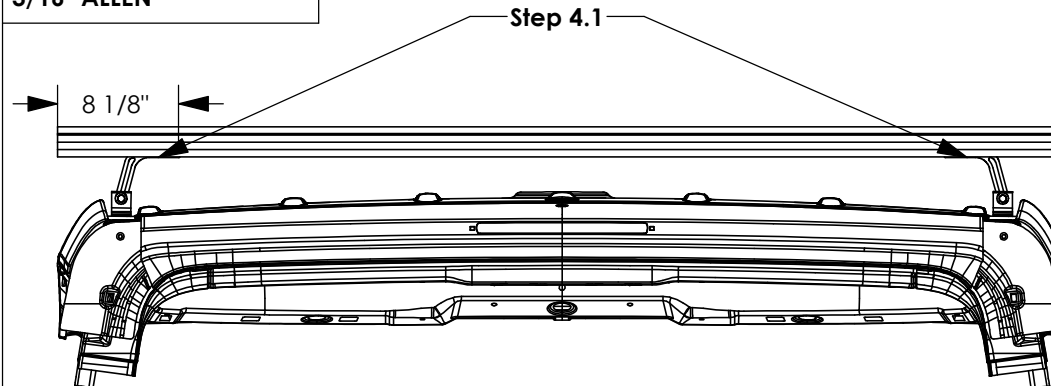



Mounting Bracket Kit, 4-Pack, White, Sprinter

PRODUCT WEIGHT
4.2 LBS

HEIGHT OFF ROOF

SEE TABLE BELOW

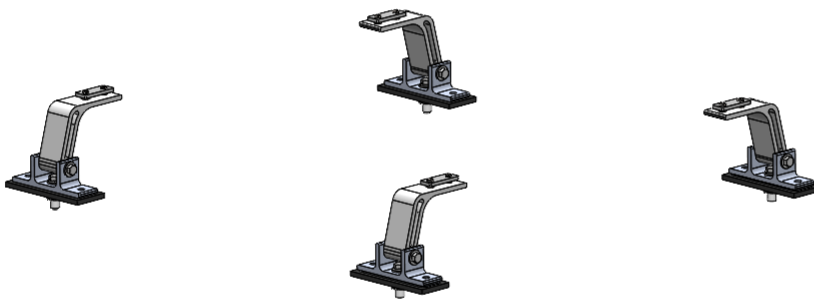

CAPACITY
**REFER TO OEM'S
RECOMMENDED LOAD
RATING**
COLOR

WHITE

CATALOG NUMBER

SPMBK4W

PRODUCT FEATURES

Mercedes Sprinter aluminum mounting bracket kit for the PROFILE™ HD Utility Rack. Mounting kit works for low roof vehicles without the OEM roof rail option. Can be mounted to any OEM mounting locations to best fit customer's product.

Utility racks are not recommended for high roof vehicles!

Does not work with grip lock or drop down style racks.

SEE PAGE 2 FOR APPLICATION NOTES AND ACCESSORIES, OTHER PRODUCTS THAT WORK WITH THIS UNIT.

PAGE 1 of 2

The information contained in this document is the sole property of ADRIAN STEEL COMPANY. ADRIAN STEEL COMPANY retains the right to modify and/or change the product of its design at any time without prior notification.



CATALOG NUMBER SPMBK4W

PRODUCT APPLICATION

This product is designed to be installed on Mercedes Sprinter vans without OEM roof rail option. HD Utility Racks are not recommended for high roof vehicles!

ACCESSORIES THAT WILL WORK WITH THIS PRODUCT

CATALOG NUMBER	DESCRIPTION	CATALOG NUMBER	DESCRIPTION
SPMBK2W	Mounting Bracket Kit, 2-Pack, White, Sprinter	4UPK4B	4" Upright Kit, 4-Pack, Black
2BARW	2-Crossbar Kit, 68", White, Full Size Van	4UPK2B	4" Upright Kit, 2-Pack, Black
1BARW	Single Crossbar Kit, 68", White, Full Size Van	6UPK4B	6" Upright Kit, 4-Pack, Black
RRBSPW*	Rear Roller Assist Bar, White, Sprinter	6UPK2B	6" Upright Kit, 2-Pack, Black
70-1NGLR	4" End Cap for PVC Conduit	9UPK4B	9" Upright Kit, 4-Pack, Black
70-2NGLR	6" End Cap for PVC Conduit	9UPK2B	9" Upright Kit, 2-Pack, Black
80-1NGLR	Conduit Kit, 10w x 6h x 126d, Multiple Vehicles	RSK1B	Single Ratchet Upright Kit, 9"
80-2NGLR	Conduit Kit, 10w x 6h x 150d, Multiple Vehicles	ULSKB	Single Ladder Stop Kit

*Does not work with high roof vehicles!

LADDER RACK HEIGHTS MEASURED FROM ROOF OF VEHICLE

CONFIGURATION	RACK HEIGHT LOW / HIGH ROOF
Base Rack	4.3" / 4.9"
Base + Ladder Stop	9.8" / 10.4"
Base + 4" Uprights	7.8" / 8.4"
Base + 6" Uprights	9.8" / 10.4"
Base + 9"/Ratchet Uprights	12.8" / 13.4"
Base + 4" PVC Conduit Kit	8.7" / 9.3"
Base + 6" PVC Conduit Kit	10.7" / 11.3"
Base + Aluminum Box Conduit Kit	10.8" / 11.4"

Single Ladder Stop Kit

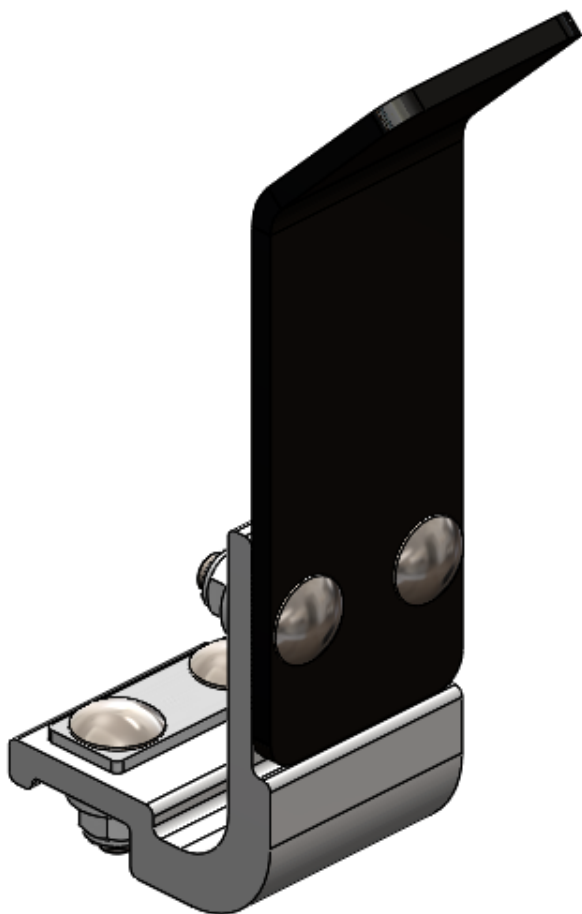

PRODUCT WEIGHT
1.3 LBS

WIDTH x DEPTH x HEIGHT
2" x 1.8" x 6.3"

CAPACITY
N/A

COLOR
BLACK

CATALOG NUMBER
ULSKB

PRODUCT FEATURES

Aluminum ladder stop kit with plastisol coating for PROFILE™ HD Utility and combo ladder racks. Works on all vehicle platforms. Works with all upright kits, conduit kits, and rear rollers.

Utility style ladder racks are not recommended for medium and high roof vehicles!

Please refer to OEM specific mounting kit and rail kit for additional information on compatible accessories.

SEE PAGE 2 FOR APPLICATION NOTES AND ACCESSORIES, OTHER PRODUCTS THAT WORK WITH THIS UNIT.



CATALOG NUMBER ULSKB

PRODUCT APPLICATION

This product is for PROFILE™ HD Utility and combo ladder racks. Works on all vehicle platforms. Utility style ladder racks are not recommended for medium or high roof vehicles!

ACCESSORIES THAT WILL WORK WITH THIS PRODUCT

CATALOG NUMBER	DESCRIPTION
2BARW	2-Crossbar Kit, 68”, White, Full Size Van
2BARCW	2-Crossbar Kit, 58”, White, Minivan
1BARW	Single Crossbar Kit, 68”, White, Full Size Van
1BARCW	Single Crossbar Kit, 58”, White, Minivan

<i>INSTR. NUMBER</i> : 64337	<i>PG.</i> : 1	<i>REV.</i> : C	<i>ITEM NO.</i>	<i>PART NUMBER</i>	<i>DESCRIPTION</i>	<i>QTY.</i>
			1	63854-W	UTILITY,CONNECTING BRKT,W	1
<i>PART NUMBER</i> : ULSKB			2	63850-B	UTILITY, LADDER STOP, B	1
<i>PART DESC.</i> : UTILITY, LADDER STOP KIT						

NOTE: THIS INSTRUCTION IS INTENDED TO BE USED WITH THE #BARW OR #BARCW UTILITY RACKS.

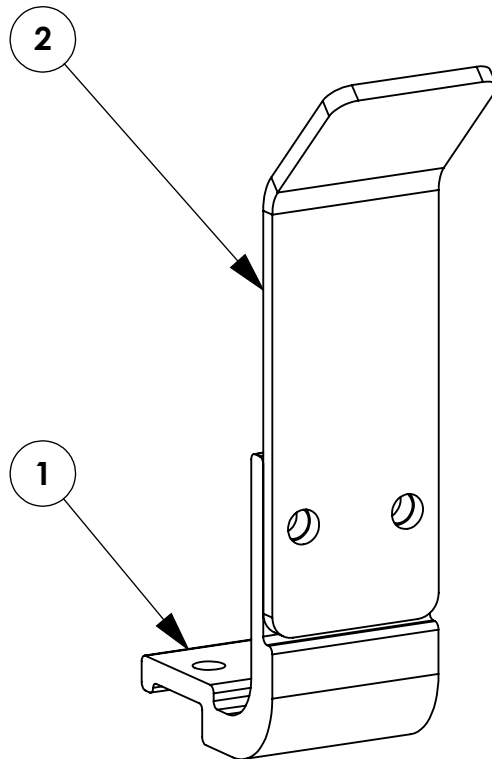

GET TO KNOW THE VEHICLE - AT THE BEGINNING OF ANY INSTALLATION, CHECK THE LOCATION OF THE FUEL TANK, FUEL LINES, BRAKE LINES, HIGH VOLTAGE BATTERIES AND WIRING HARNESES TO AVOID INJURY OR PROPERTY DAMAGE FROM TOOL CONTACT.

SEAL ALL EXTERIOR HOLES - ALL INSTALLATION HOLES SHOULD BE SEALED WITH BUTYL TAPE OR SILICON TO PREVENT WATER AND EXHAUST GASES FROM ENTERING THE VEHICLE.

CONTROL DRILL DEPTH - TO AVOID DAMAGE TO THE VEHICLE, USE A DRILL STOP OR CLEARED STEP BIT WHEN DRILLING INSTALLATION HOLES.

ALWAYS ADD PRIMER - WHEN ADDING INSTALLATION HOLES BE SURE TO USE A SELF-ETCHING PRIMER TO PREVENT CORROSION, FASTENER FAILURE AND INJURY.

MOUNTING POINTS MUST HAVE METAL-TO-METAL CONTACT - USE PROVIDED MOUNTING SPACERS TO ACCOMMODATE FOR VEHICLE FEATURES, CARPET OR SUBFLOORS.

PROVIDE CLEARANCE FOR SPACERS - IF THE INSTALLATION VEHICLE CONTAINS A CARPET OR SUBFLOOR, USE A 1-3/16" DIAMETER CARPET CUTTER (P/N: 31183-0) AT ALL MOUNTING LOCATIONS TO OPEN UP ROOM FOR SPACERS.

CHECK SPACER ORIENTATION - BE SURE THAT THE INDENT IN THE SPACER COVERS THE PLUSNUT HEAD; THIS ENSURES THE MOST METAL-TO-METAL CONTACT AND REDUCES VIBRATION.

PLUSNUT INSTALLATION - A PLUSNUT GUN IS RECOMMENDED FOR PLUSNUT INSTALLATION FOR ITS PRODUCTION SPEED. HOWEVER, A PLUSNUT SETTING TOOL CAN ALSO BE USED (P/N: 22200-0).

THRU-BOLT CLEARANCE - WHEN USING A THRU-BOLT AT ANY MOUNTING LOCATION, BE SURE THAT YOUR HOLE HAS 1/16" CLEARANCE.

FASTENERS USED

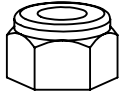

**FAS0248
5/16-18 SS
NLK HEX NUT
QTY: 4**

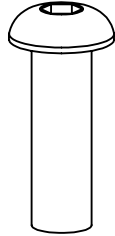

**FAS0813
5/16-18X1.0 SS
BHCS SCREW
QTY: 4**



**FAS0552
5/16 SS
FLAT WASHER
QTY: 4**

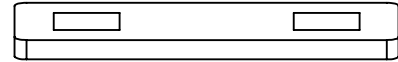

**63934
UTILITY,
BOLT PLATE
QTY: 1**

BEGIN ASSEMBLY
STEP 1 - ASSEMBLE BRACKET

(2)FAS0813, (4)FAS0552,
(2)FAS0248
1/2 SOCKET
3/16 HEX DRIVE

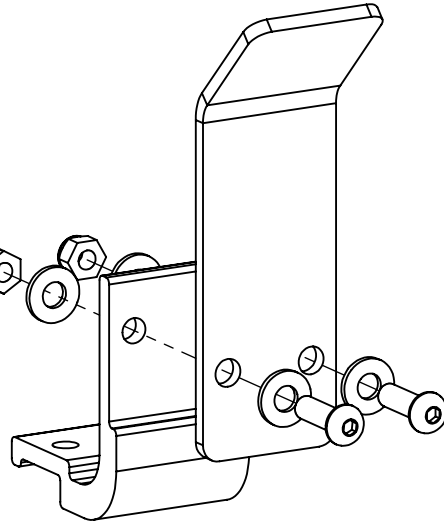

BEGIN INSTALLATION
STEP 2 - INSTALL BRACKET

(2)FAS0398, 63934
(2)FAS0552, (2)FAS0248
1/2 SOCKET

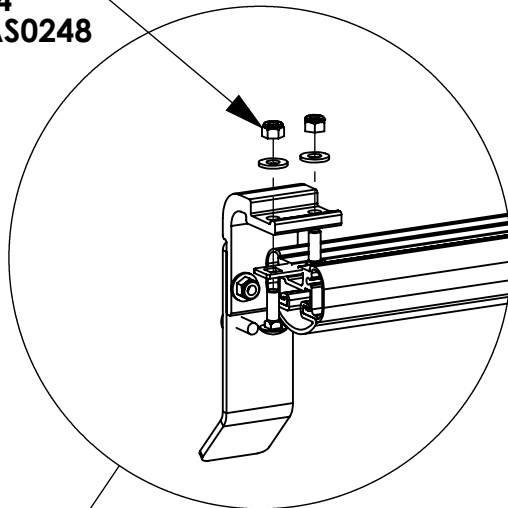

MAKE SURE THE LADDER STOP IS BETWEEN THE CARRIAGE BOLT AND PLATE ASSEMBLY FOR EACH MOUNTING BRACKET.

ADJUST LADDER STOP TO BE IN THE CENTER OF CARGO

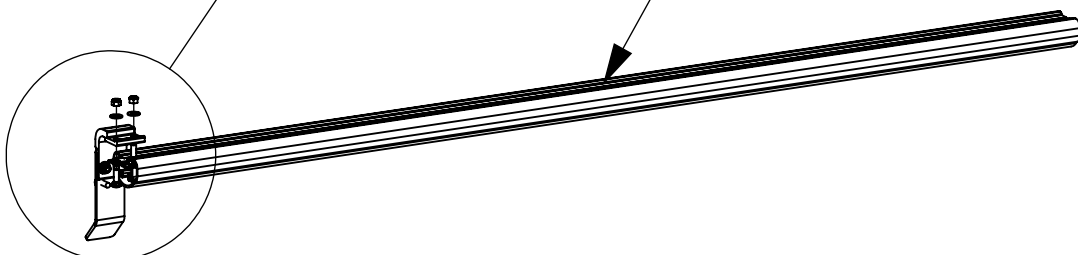



Single Crossbar Kit, 68", White, Full Size Van



PRODUCT WEIGHT
9.6 LBS

CROSSBOW LENGTH X
HEIGHT

69" x 2"

CAPACITY

**REFER TO OEM'S
RECOMMENDED LOAD
RATING**

COLOR

WHITE

CATALOG NUMBER

1BARW

PRODUCT FEATURES

Aluminum base 1-crossbow kit for PROFILE™ HD Utility, grip lock, drop down, or combo ladder racks for 3+Bar racks. Works with all full size van platforms for each respective wheelbase and roof height combination. Works with and without OEM specific rail kit and generic mounting bracket kits.

Optional uprights, conduit kits, and rear rollers available.

Utility and grip lock ladder racks are not recommended for medium and high roof vehicles!

Please refer to OEM specific mounting kit or rail kit for additional information on compatible accessories.

INSTALLATION GUIDE FOR PROFILE™ SERIES LADDER RACKS

INSTRUCTION #:
68895

REV:
C



THIS INSTRUCTION PROVIDES A GENERAL GUIDE OF INSTALLATION SEQUENCE FOR ALL PROFILE™ SERIES LADDER RACKS. PLEASE ENSURE ALL ACCESSORIES ARE INSTALLED PER TYPE OF RACK BEFORE PROCEEDING TO NEXT PAGE.

REFERENCE THIS INSTRUCTION THROUGHOUT THE ENTIRETY OF YOUR INSTALL TO PREVENT ACCESSORIES BEING INSTALLED INCORRECTLY/OUT OF SEQUENCE!

STEPS 2T - 8T ON PAGE 3 IS THE RECOMMENDED ASSEMBLY SEQUENCE FOR A FULL TABLE ASSEMBLY BEFORE INSTALLING ON THE ROOF OF THE VEHICLE.

STEPS 2R - 8R ON PAGE 4 IS AN ALTERNATE ASSEMBLY SEQUENCE TO INSTALL THE RACK ON THE VEHICLE ROOF AS IT IS BUILT.

PLEASE SELECT THE ASSEMBLY SEQUENCE THAT BEST WORKS FOR YOU!

ASSEMBLY STEPS:

STEP 1A. *SUB-ASSEMBLE EACH CROSSBOW WITH DESIRED ACCESSORIES FOR SECTIONS A.1 & A.2.*

INSTRUCTIONS FOR EACH KIT CAN BE FOUND IN THEIR RESPECTIVE CARTON!

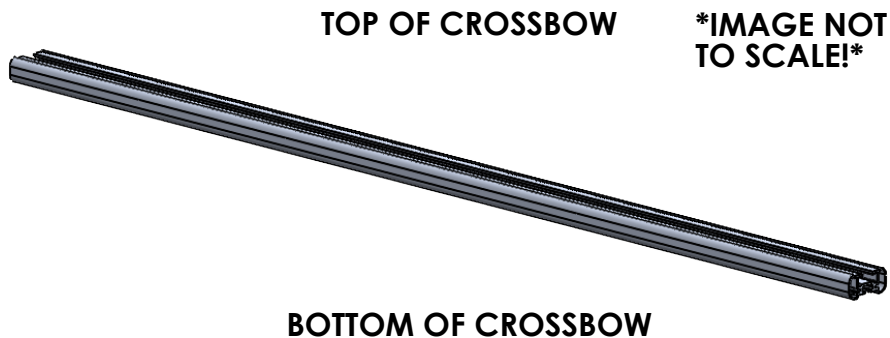

TABLE 1

TOP OF CROSSBOW

COMPONENTS TO INSTALL

A.1	HD UTILITY	- CONDUIT KIT OR BEACON
	Grip-Lock	- CONDUIT KIT OR BEACON
	ProLift	- CONDUIT KIT OR BEACON

BOTTOM OF CROSSBOW

COMPONENTS TO INSTALL

A.2	HD UTILITY	- LADDER STOP, STROBE BRACKET, AND/OR REAR ROLLER
	Grip-Lock	- Grip-Lock SUB-ASSEMBLY
	ProLift	- DAMPER BRACKET

STEP 1B. SUB-ASSEMBLE EACH CROSSBOW WITH DESIRED ACCESSORIES FOR SECTIONS B.1 & B.2. INSTRUCTIONS FOR EACH KIT CAN BE FOUND IN THEIR RESPECTIVE CARTON!



ALTER WEAR STRIP AND INSTALL ON CROSSBOW (IF APPLICABLE)! REFERENCE TABLE 3 BELOW FOR WEAR STRIP ALTERATION INSTRUCTIONS!

TABLE 3

ADDED ACCESSORIES	ALTERATION FOR WEAR STRIP
4" UPRIGHT***	REMOVE 2" FROM END OF WEAR STRIP
4" PVC CONDUIT KIT	REMOVE 7.25" FROM CENTER OF WEAR STRIP
6" PVC CONDUIT KIT	REMOVE 9.50" FROM CENTER OF WEAR STRIP
ALUMINUM BOX CONDUIT KIT	REMOVE 13.25" FROM CENTER OF WEAR STRIP
BEACON	REMOVE 4" FROM CENTER OF WEAR STRIP
ProLift (SINGLE SIDE)	CUT WEAR STRIP IN HALF, DO NOT INSTALL ON ProLift SIDE
ProLift (DUAL SIDE)	DO NOT INSTALL WEAR STRIP

TABLE 2

TOP OF CROSSBOW		
COMPONENTS TO INSTALL		
B.1	HD UTILITY	- WEAR STRIP (MODIFY IF NECESSARY, TABLE 3)
	Grip-Lock	- WEAR STRIP (MODIFY IF NECESSARY, TABLE 3)
	ProLift	- INNER STOP POST
BOTTOM OF CROSSBOW		
COMPONENTS TO INSTALL		
B.2	HD UTILITY	- MOUNTING BRACKETS
	Grip-Lock	- MOUNTING BRACKETS
	ProLift	- MOUNTING BRACKETS

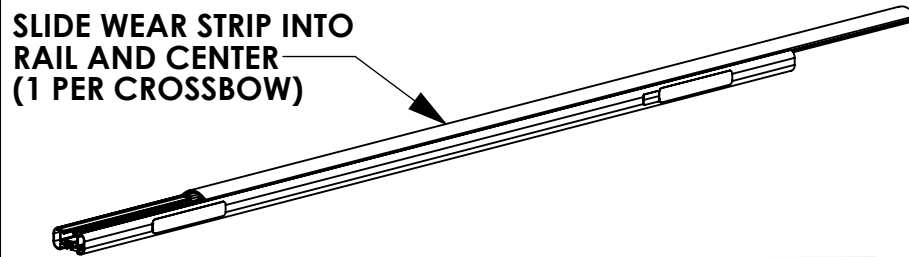

SLIDE ONE SIDE OF WEAR STRIP INTO CROSSBOW, THEN ROLL OTHER SIDE TO SNAP STRIP INTO PLACE

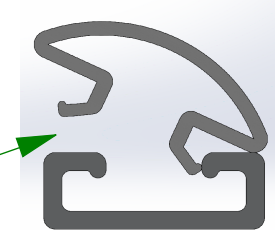

STEP 1C SUB-ASSEMBLE EACH CROSSBOW WITH DESIRED ACCESSORIES FOR SECTIONS C.1 & C.2



ASSEMBLY STEPS (FULL BENCH ASSEMBLY):

- 2T. ADD DRIVELINES (IF INSTALLING ProLift)
- 3T. ADD HANDLES (IF INSTALLING Grip-Lock OR ProLift) AND DAMPERS (IF INSTALLING ProLift)
- 4T. ADD OUTER SUPPORT BARS (IF INSTALLING Grip-Lock OR ProLift)
- 5T. ADD STEP LADDER KIT (Grip-Lock OR ProLift ONLY!)

6T. ASSEMBLE ENDS CAPS TO CROSSBOW

USED FOR HD UTILITY & Grip-Lock RACKS

LOCATED IN CROSSBOW KIT

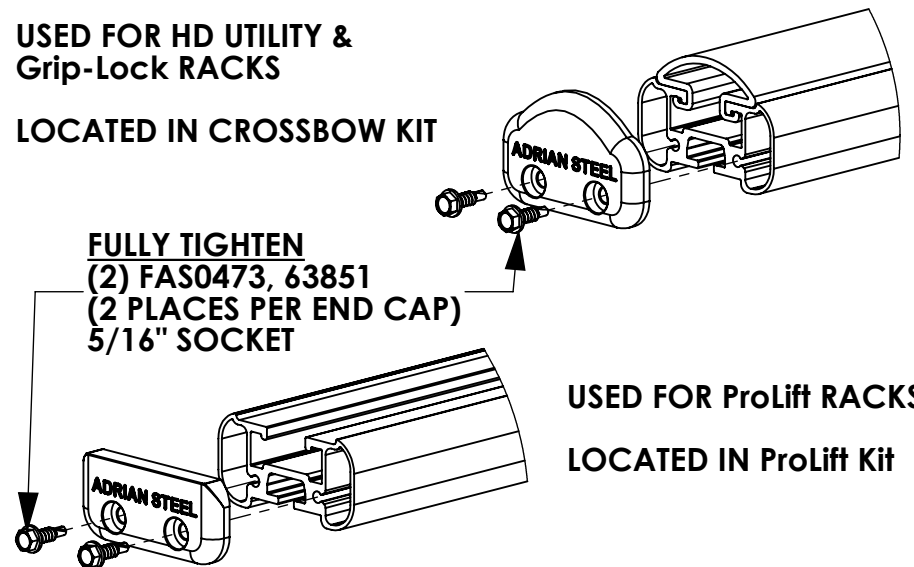

USED FOR ProLift RACKS
LOCATED IN ProLift Kit

7T. INSTALL ROOF RAIL KIT ON VEHICLE ROOF OR BOTTOM MOUNTING BRACKETS

(ROOF RAIL KIT REQUIRED FOR Grip-Lock & ProLift OPTIONAL FOR HD UTILITY, NOT NEEDED FOR GM LADDER RACKS)

8T. MOUNT CROSSBOW SUB-ASSEMBLIES FROM STEP 1 TO VEHICLE/MOUNTING BRACKET, OR ROOF RAIL (LOOSE INSTALL)

TABLE 4

TOP OF CROSSBOW		
COMPONENTS TO INSTALL		
C.1	HD UTILITY	- 4" UPRIGHT
	Grip-Lock	- N/A
	ProLift	- SLIDES FOR BASE EXTRUSION
BOTTOM OF CROSSBOW		
COMPONENTS TO INSTALL		
C.2	HD UTILITY	- UPRIGHTS (6", 9", RATCHET)
	Grip-Lock	- STROBES
	ProLift	- STROBES

ALTERNATE ASSEMBLY METHOD!
(ASSEMBLE ON VEHICLE ROOF):

2R. INSTALL ROOF RAIL KIT ON VEHICLE ROOF OR BOTTOM MOUNTING BRACKETS

(ROOF RAIL KIT REQUIRED FOR Grip-Lock & ProLift, OPTIONAL FOR HD UTILITY, NOT NEEDED FOR GM LADDER RACKS)

3R. MOUNT CROSSBOW SUB-ASSEMBLIES FROM STEP 1 TO VEHICLE/MOUNTING BRACKET, OR ROOF RAIL (LOOSE INSTALL)

4R. ADD DRIVELINES (IF INSTALLING ProLift)

5R. ADD HANDLES (IF INSTALLING Grip-Lock OR ProLift) AND DAMPERS (IF INSTALLING ProLift)

6R. ADD OUTER SUPPORT BARS (IF INSTALLING Grip-Lock OR ProLift)

7R. ADD STEP LADDER KIT (Grip-Lock OR ProLift ONLY!)

8R. ASSEMBLE END CAPS TO CROSSBOW

USED FOR HD UTILITY &
Grip-Lock RACKS

LOCATED IN CROSSBOW KIT

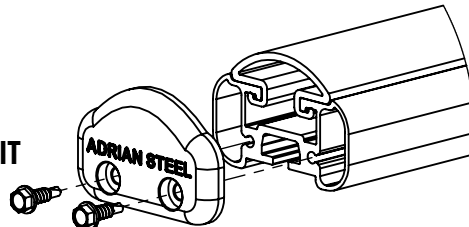

FULLY TIGHTEN
(2) FAS0473, 63851
(2 PLACES PER END CAP)
5/16" SOCKET

USED FOR ProLift RACKS
LOCATED IN ProLift Kit

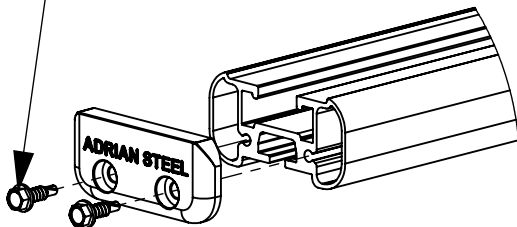



2-Crossbar Kit, 68", White, Full Size Van



PRODUCT WEIGHT
19 LBS

CROSSBOW LENGTH X
HEIGHT

69" x 2"

CAPACITY

**REFER TO OEM'S
RECOMMENDED LOAD
RATING**

COLOR

WHITE

CATALOG NUMBER

2BARW

PRODUCT FEATURES

Aluminum base 2-crossbow kit for PROFILE™ HD Utility, grip lock, drop down, or combo ladder racks. Works with all full size van platforms for each respective wheelbase and roof height combination. Works with and without OEM specific rail kit and generic mounting bracket kits.

Additional crossbows and optional uprights, conduit kits, and rear rollers available.

Utility and grip lock ladder racks are not recommended for medium and high roof vehicles!

Please refer to OEM specific mounting kit or rail kit for additional information on compatible accessories.

6" Upright Kit, 2-Pack, Black

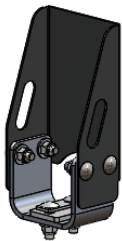

PRODUCT WEIGHT
4.6 LBS

WIDTH x DEPTH x HEIGHT

3.8" x 2.3" x 6"

CAPACITY

N/A

COLOR

BLACK

CATALOG NUMBER

6UPK2B

PRODUCT FEATURES

Galvanized steel 6" uprights fully plastisol coated for PROFILE™ HD Utility and combo ladder racks. Works on all vehicle platforms. Works with all conduit kits and rear rollers.

Utility style ladder racks are not recommended for medium and high roof vehicles!

Please refer to OEM specific mounting kit and rail kit for additional information on compatible accessories.

SEE PAGE 2 FOR APPLICATION NOTES AND ACCESSORIES, OTHER PRODUCTS THAT WORK WITH THIS UNIT.

PAGE 1 of 2

The information contained in this document is the sole property of ADRIAN STEEL COMPANY. ADRIAN STEEL COMPANY retains the right to modify and/or change the product of its design at any time without prior notification.



CATALOG NUMBER 6UPK2B

PRODUCT APPLICATION

This product is for PROFILE™ HD Utility and combo ladder racks. Works on all vehicle platforms. Utility style ladder racks are not recommended for medium or high roof vehicles!

ACCESSORIES THAT WILL WORK WITH THIS PRODUCT

CATALOG NUMBER	DESCRIPTION
2BARW	2-Crossbar Kit, 68”, White, Full Size Van
2BARCW	2-Crossbar Kit, 58”, White, Minivan
1BARW	Single Crossbar Kit, 68”, White, Full Size Van
1BARCW	Single Crossbar Kit, 58”, White, Minivan

INSTR. NUMBER : 65319	PG: 1	REV: C	ITEM NO.	PART NUMBER	DESCRIPTION	QTY.
PART NUMBER • 6UPK2B PART NUMBER • 9UPK2B			1	65120-W	UTILITY,UPR MOUNT BRKT,W	2
			2	63848-B	UTILITY, UPRIGHT, 6", B	2
PART • UTILITY,6" UPRIGHT KIT,2B DESC. • UTILITY,9" UPRIGHT KIT,2B			3*	65120-W	UTILITY,UPR MOUNT BRKT,W	2
			4*	64060-B	UTILITY, UPRIGHT, 9", B	2

NOTE: THIS INSTRUCTION IS VALID FOR THE FOLLOWING UPRIGHT KITS:

6UPK2B (SHOWN)

6UPK4B

9UPK2B

9UPK4B

ITEMS NOTED (#*) ARE PART OF 9UPK2B

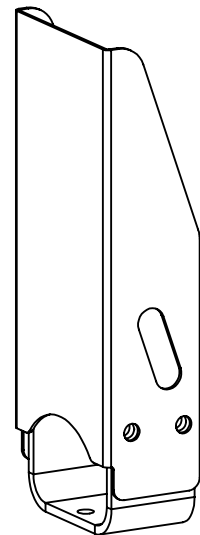
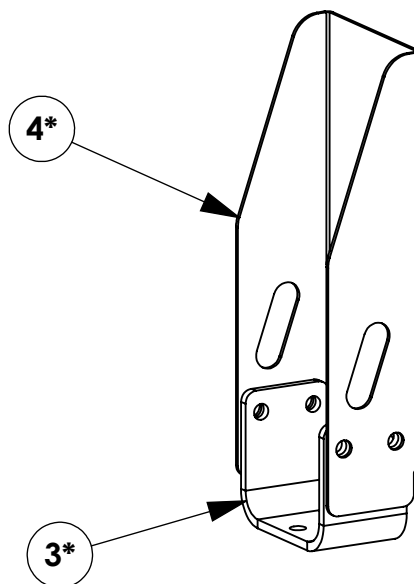
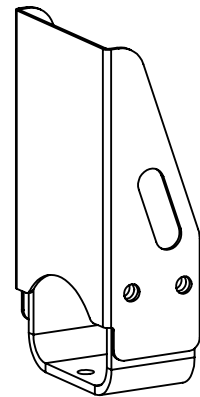
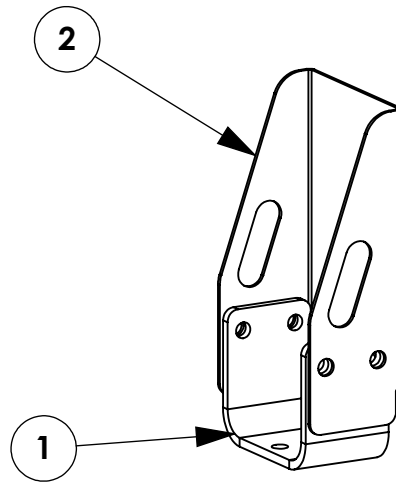

GET TO KNOW THE VEHICLE - AT THE BEGINNING OF ANY INSTALLATION, CHECK THE LOCATION OF THE FUEL TANK, FUEL LINES, BRAKE LINES, HIGH VOLTAGE BATTERIES AND WIRING HARNESSSES TO AVOID INJURY OR PROPERTY DAMAGE FROM TOOL CONTACT.

SEAL ALL EXTERIOR HOLES - ALL INSTALLATION HOLES SHOULD BE SEALED WITH BUTYL TAPE OR SILICON TO PREVENT WATER AND EXHAUST GASES FROM ENTERING THE VEHICLE.

CONTROL DRILL DEPTH - TO AVOID DAMAGE TO THE VEHICLE, USE A DRILL STOP OR CLEARED STEP BIT WHEN DRILLING INSTALLATION HOLES.

ALWAYS ADD PRIMER - WHEN ADDING INSTALLATION HOLES BE SURE TO USE A SELF-ETCHING PRIMER TO PREVENT CORROSION, FASTENER FAILURE AND INJURY.

MOUNTING POINTS MUST HAVE METAL-TO-METAL CONTACT - USE PROVIDED MOUNTING SPACERS TO ACCOMMODATE FOR VEHICLE FEATURES, CARPET OR SUBFLOORS.

PROVIDE CLEARANCE FOR SPACERS - IF THE INSTALLATION VEHICLE CONTAINS A CARPET OR SUBFLOOR, USE A 1-3/16" DIAMETER CARPET CUTTER (P/N: 31183-0) AT ALL MOUNTING LOCATIONS TO OPEN UP ROOM FOR SPACERS.

CHECK SPACER ORIENTATION - BE SURE THAT THE INDENT IN THE SPACER COVERS THE PLUSNUT HEAD; THIS ENSURES THE MOST METAL-TO-METAL CONTACT AND REDUCES VIBRATION.

PLUSNUT INSTALLATION - A PLUSNUT GUN IS RECOMMENDED FOR PLUSNUT INSTALLATION FOR ITS PRODUCTION SPEED. HOWEVER, A PLUSNUT SETTING TOOL CAN ALSO BE USED (P/N: 22200-0).

THRU-BOLT CLEARANCE - WHEN USING A THRU-BOLT AT ANY MOUNTING LOCATION, BE SURE THAT YOUR HOLE HAS 1/16" CLEARANCE.

FASTENERS USED

**QUANTITIES ARE LISTED FOR 6UPK2B / 9UPK2B.
QUANTITIES WILL VARY BASED ON NUMBER OF UPRIGHTS**

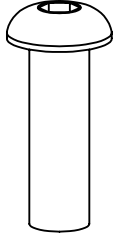

FAS0813
5/16-18x1.0 SS
BHCS SCREW
QTY: 8

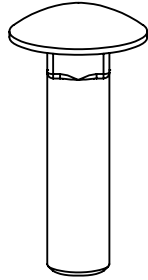

FAS0812
5/16-18x1.25 SS
CRG BOLT
QTY: 4



FAS0552
5/16 SS
FLAT WASHER
QTY: 12

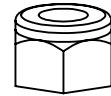

FAS0248
5/16-18 SS
NLK HEX NUT
QTY: 12

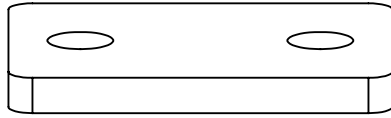

63933
UTILITY,
SPACER
QTY: 2

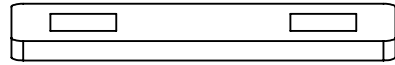

63934
UTILITY,
BOLT PLATE
QTY: 2

BEGIN ASSEMBLY
STEP 1 - ASSEMBLE UPRIGHTS

FAS0813, (2) FAS0552,
AND FAS0248
(4 PLACES PER UPRIGHT)
3/16 HEX DRIVE
1/2 SOCKET

DRILL HOLES IN UPRIGHT
WITH 11/32" DRILL BIT
BEFORE ASSEMBLING!
(4 PLACES PER UPRIGHT)

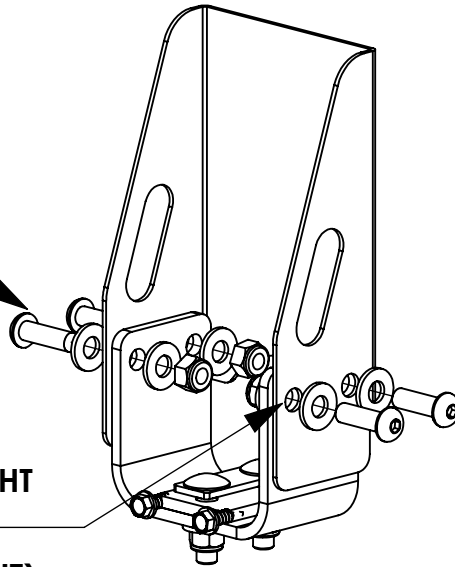

BEGIN INSTALLATION
STEP 2 - INSTALL UPRIGHTS

(2) FAS0812, (2) FAS0552,
63933, 63934, & (2) FAS0248
(PER UPRIGHT)
1/2 SOCKET

ALIGN UPRIGHT WITH
EDGE OF CROSSBOW

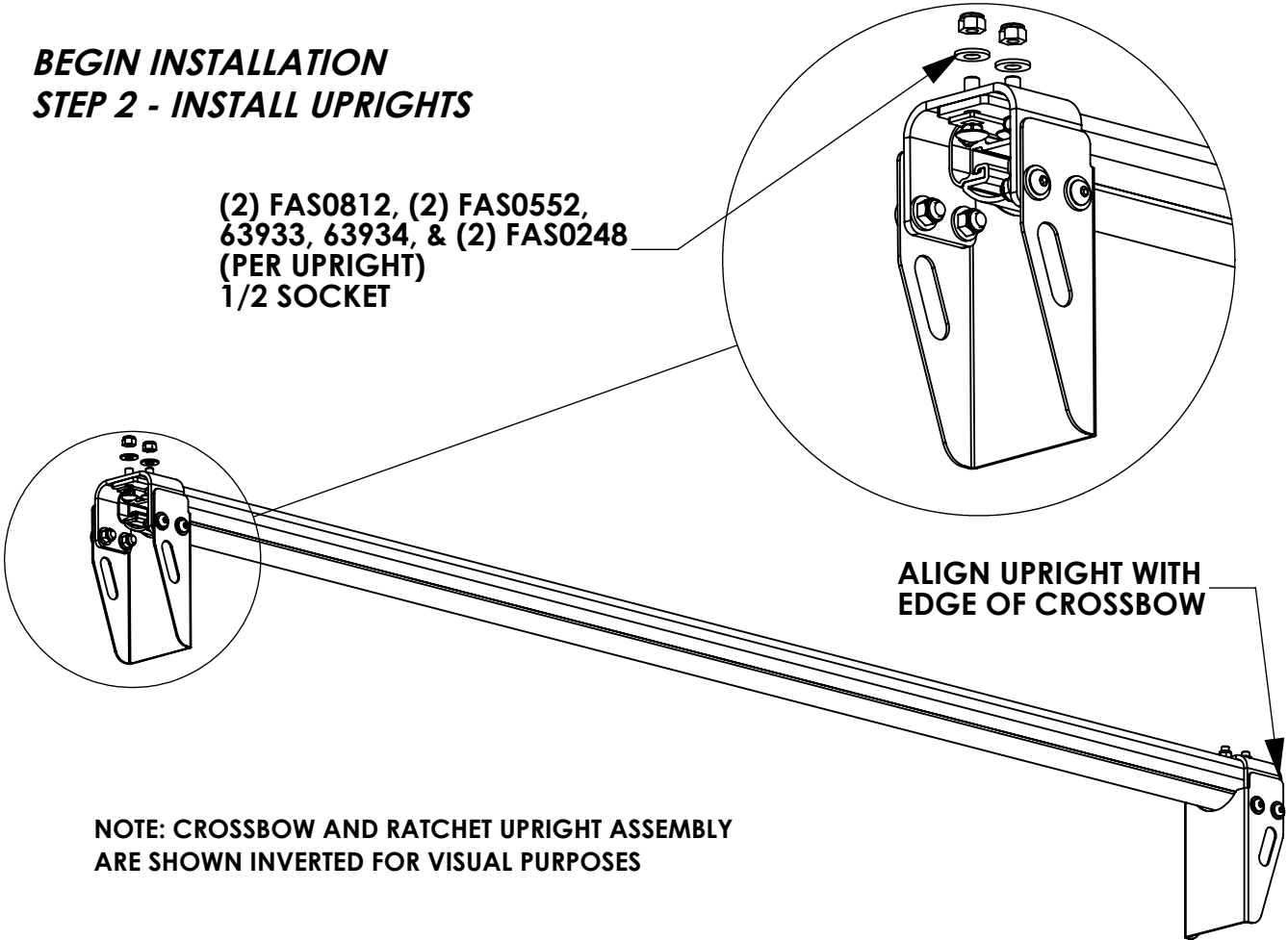

NOTE: CROSSBOW AND RATCHET UPRIGHT ASSEMBLY
ARE SHOWN INVERTED FOR VISUAL PURPOSES

CONTINUE WITH INSTALLATION WITH THE MOUNTING KIT INSTRUCTIONS



6" Upright Kit, 4-Pack, Black

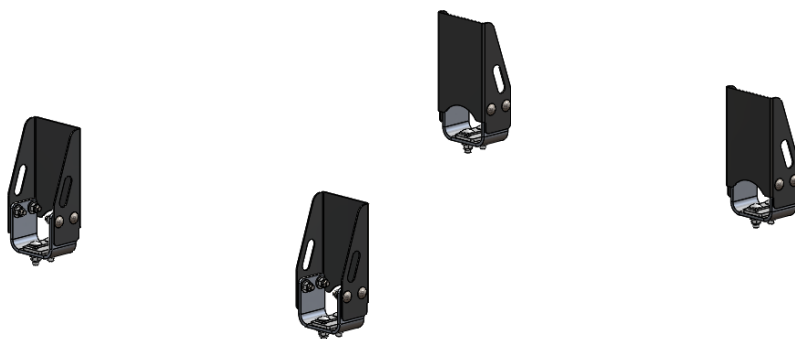

PRODUCT WEIGHT
9.3 LBS

WIDTH x DEPTH x HEIGHT
3.8" x 2.3" x 6"

CAPACITY
N/A

COLOR
BLACK

CATALOG NUMBER
6UPK4B

PRODUCT FEATURES

Galvanized steel 6" uprights fully plastisol coated for PROFILE™ HD Utility and combo ladder racks. Works on all vehicle platforms. Works with all conduit kits and rear rollers.

Utility style ladder racks are not recommended for medium and high roof vehicles!

Please refer to OEM specific mounting kit and rail kit for additional information on compatible accessories.

SEE PAGE 2 FOR APPLICATION NOTES AND ACCESSORIES, OTHER PRODUCTS THAT WORK WITH THIS UNIT.

PAGE 1 of 2

The information contained in this document is the sole property of ADRIAN STEEL COMPANY. ADRIAN STEEL COMPANY retains the right to modify and/or change the product of its design at any time without prior notification.



CATALOG NUMBER 6UPK4B

PRODUCT APPLICATION

This product is for PROFILE™ HD Utility and combo ladder racks. Works on all vehicle platforms. Utility style ladder racks are not recommended for medium or high roof vehicles!

ACCESSORIES THAT WILL WORK WITH THIS PRODUCT

CATALOG NUMBER	DESCRIPTION
2BARW	2-Crossbar Kit, 68”, White, Full Size Van
2BARCW	2-Crossbar Kit, 58”, White, Minivan
1BARW	Single Crossbar Kit, 68”, White, Full Size Van
1BARCW	Single Crossbar Kit, 58”, White, Minivan