

FORD TRANSIT



ADRIAN STEEL®

Cargo Management Solutions for Commercial Vehicles



**TRANSIT & TRANSIT CONNECT
PRODUCT CATALOG**



TIME IS MONEY! GET ON THE ROAD WITH EVERYTHING YOU NEED!

Adrian Steel has the storage products you need, with a nationwide distributor network for professional installation. This catalog will help you set up your work van with the equipment you need to get the job done. Start with a partition to keep your cargo in the cargo area. Choose the shelving and modules for the curb and street side that fit your business needs. Or, choose a pre-designed trade package to start from. Add the accessories you need to make your van more organized. Carry ladders or cargo on your roof? Check out the variety of ladder and utility racks available. The options are many, so if you don't know where to start contact your local Adrian Steel distributor for the expert advice you are looking for.

\$250
Upfit assistance
ON TRANSIT

\$250
Upfit assistance
ON TRANSIT Connect

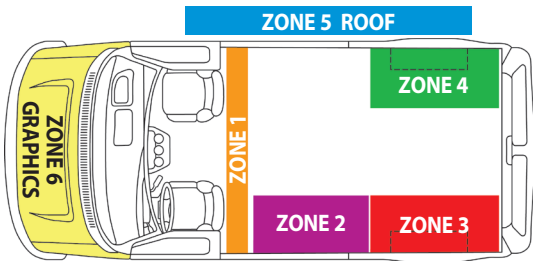

Need some help?
Contact your local distributor!
They can provide a wealth of information about utilizing the cargo space in your work van.
Find your local distributor online at adriansteel.com.

Plan Your Van

ZONE 1 PARTITION

- Choose between a Steel, Wire or Composite for the Transit and Transit Connect.

ZONES 2, 3, 4 CURBSIDE & STREETSIDE

- Use layout diagrams to determine the amount of space available.
- Choose from a variety of shelving units and modules that will best organize the tools and equipment you need to carry.
- Or, choose a Work Ready Upfit, complete with a trade specific, pre-designed interior and custom graphics package.

ZONE 5 ROOF

- What do you need to carry?
- Choose from Drop Down, Grip-Lock, and Utility racks.
- Add rack accessories including step ladder kits, ratchet straps, conduit carriers and more.

ZONE 6 VEHICLE GRAPHICS

- Stand out in the crowd!
- Vehicle graphics are the most cost effective form of advertising!

ADDITIONAL STORAGE

- Determine the space needed for specialty equipment.
- Add accessories to shelving and partition
- Hooks, drawers, files, screens, and more.

Transit Low Roof 130" WB

Notes

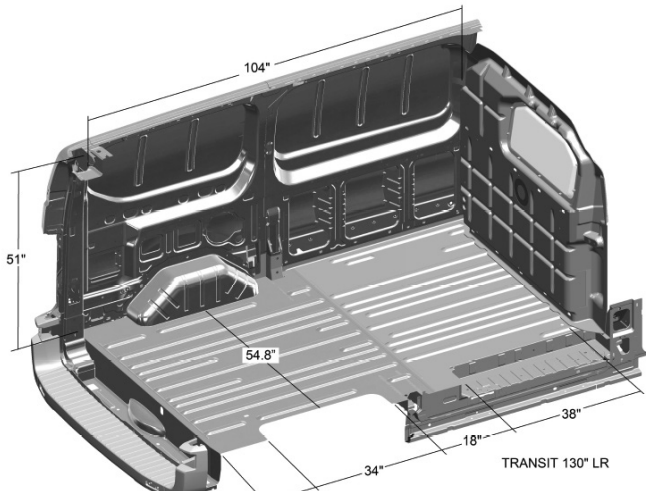

Transit Low Roof 148" WB

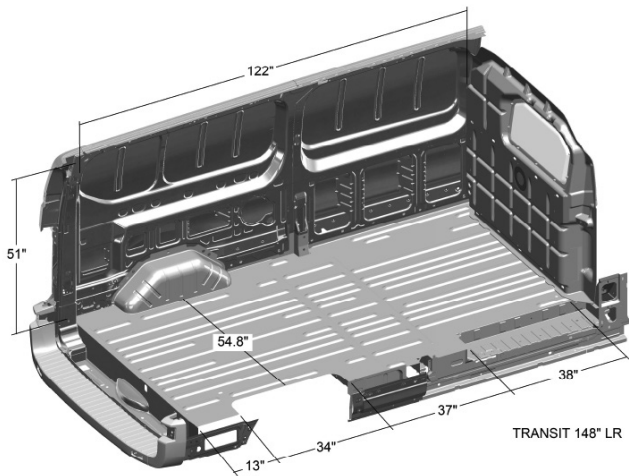

Transit Mid Roof 130" WB

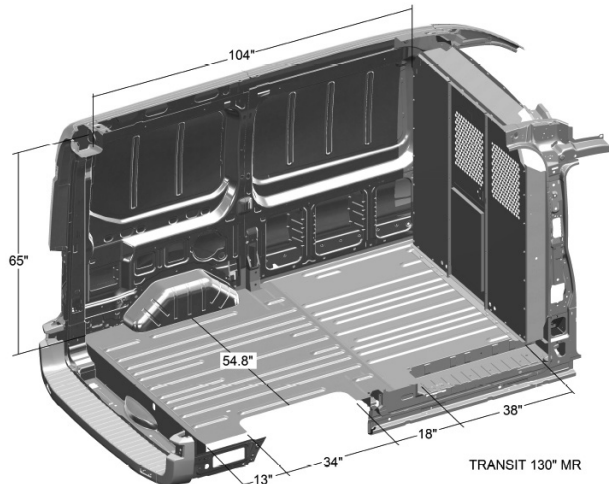

Note: Dimensions for reference only. Measure your van or contact your distributor for your exact needs.

All illustrations, photos and specifications in this publication are based on the latest product information available at the time of content approval.

The right is reserved to make changes at any time, without notice, in materials, specifications and models, and also to discontinue models.

Transit Mid Roof 148" WB

Notes

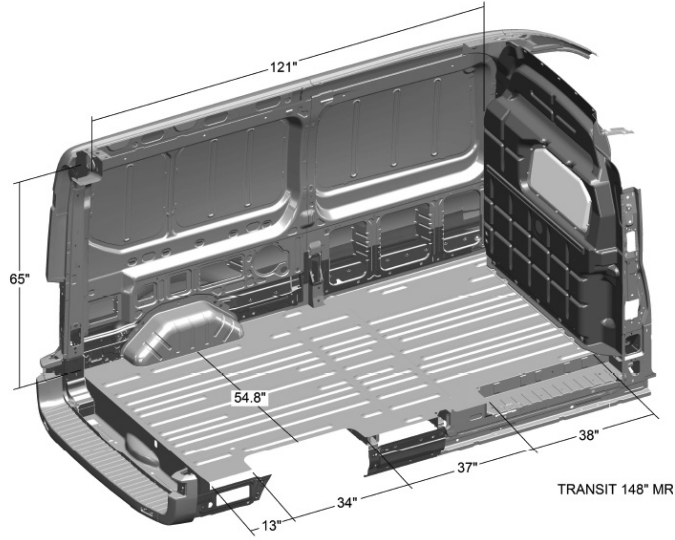

Transit High Roof 148" WB

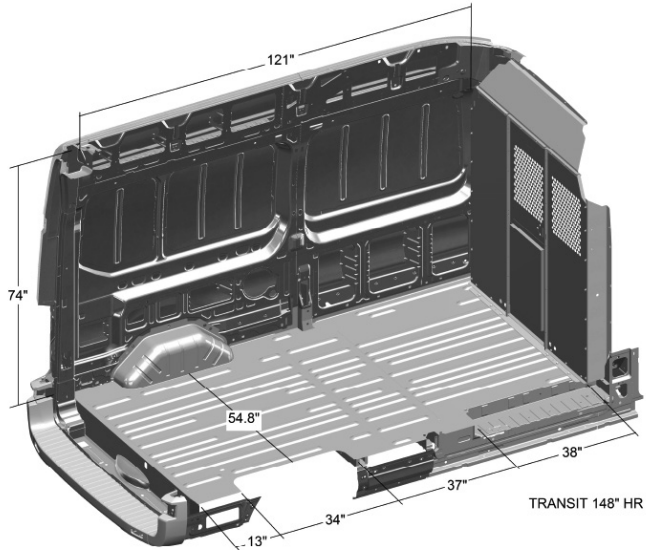

Transit High Roof 148" Extended WB

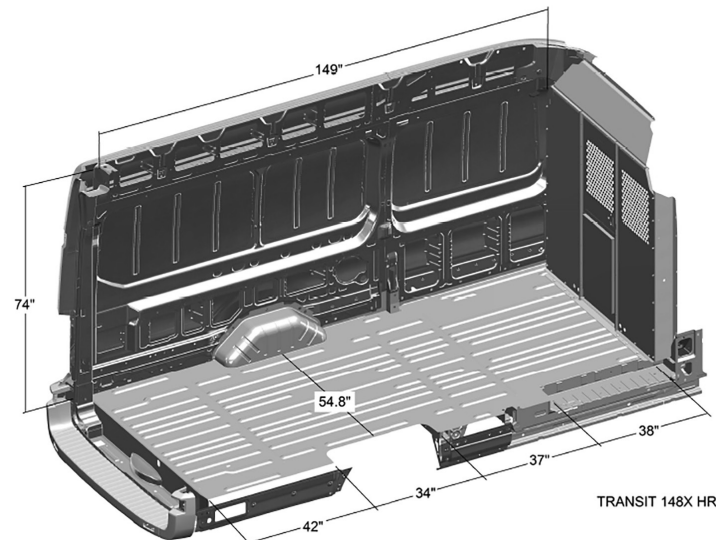

Transit Connect 105" WB

Notes

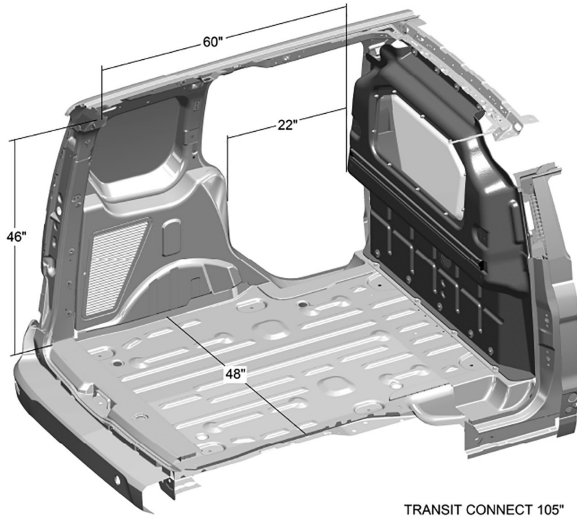

TRANSIT CONNECT 105"

Transit Connect 120" WB

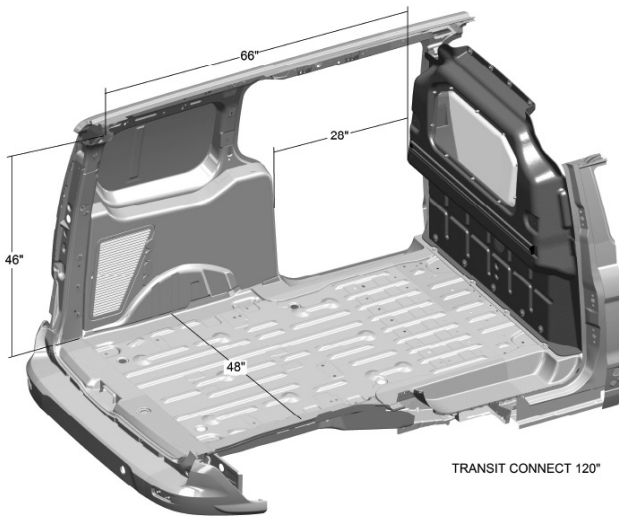

TRANSIT CONNECT 120"

Note: Dimensions for reference only. Measure your van or contact your distributor for your exact needs.

All illustrations, photos and specifications in this publication are based on the latest product information available at the time of content approval.

The right is reserved to make changes at any time, without notice, in materials, specifications and models, and also to discontinue models.

FOR A MORE COMFORTABLE MOBILE OFFICE

NEW COMPOSITE PARTITION FOR LOW ROOF TRANSIT

Your mobile office is now more comfortable with an Adrian Steel composite partition. Sound deadening reduces driver distractions. Climate control reduces vehicle idle time for warm up and cool down. Generous leg room for less stress behind the wheel. The integrated steel frame provides the same level of performance that you are accustomed to from Adrian Steel.



- Available with or without a clear poly rear-view window.
- Add hooks along the integrated AD rail.
- Features a mounting location by the door for a fire extinguisher (not included.)



PARFTL - Composite Partition w/ Visibility
PARFTL-NW - Composite Partition
UH50RM1 - Accessory Hooks

STEEL S-M-C PARTITION FOR LOW ROOF TRANSIT



- Choose from solid or perforated panels.
- Partition mounts behind the B-pillar allowing for maximum cab comfort.
- Compliant with Transit's safety features. It does not interfere with the side-curtain airbag system or seatbelts.
- Center M panels can be fixed or hinged with a key-locking door. All hinged door partitions come standard with two 6" hinges, bulb seal and a slam latch. These features reduce vibration noise.
- The MEDIUM and HIGH ROOF Transit partition door has a 60" opening height.
- Partitions feature pre-drilled holes for adding accessories easily, and larger pass-through holes for routing wiring.
- Stamped steel panels on the LOW ROOF Transit reduce product weight without sacrificing strength.

INTRODUCING THE PARTITION THAT IS ALL ABOUT DRIVER COMFORT!

There is a trend happening with cargo van owners in the market. They want a product that offers more value than the traditional steel partition provides. Something that quiets the cab area, provides more leg room and provides better climate control. Drivers that spend 8-12 hours a day working out of their mobile office want a more comfortable experience.

Adrian Steel's new line of composite partitions offers unparalleled comfort for the driver.

Organize – Partitions are great location to hang your cargo. Easily add safety items like fire extinguishers and first aid kits, or hooks to hang your extension cords or hoses. Additional accessory kits are available to customize your Adrian Steel composite partition even more.

Sound Deadening
Reduce the harshness of the cargo noise entering the cab area. This reduces driver distractions and makes for a quieter environment to communicate when driving.

Leg Room – Full seat travel and a comfortable recline angle makes the composite partition our most comfortable line of partitions we sell.

Climate Control
Quickly cool down or heat up the cab area of the cargo van, reduce idle time doing so and save fuel!

Mid Roof

- PARFTM** Composite Partition w/ Visibility
- PARFTM-NW** Composite Partition
- UH50RM1** - Accessory Hooks

High Roof

- PARFTH** Composite Partition w/ Visibility
- PARFTH-NW** Composite Partition
- UH50RM1** - Accessory Hooks



PARFTM-NW



PARFTH

STEEL S-M-C PARTITION FOR MEDIUM & HIGH ROOF TRANSIT



MEDIUM ROOF PARTITION



HIGH ROOF PARTITION

MODEL	DESCRIPTION
LOW ROOF FIXED CENTER PANEL	
S1M1C1FSV	Solid panels
S1M2C2FSV	Center and Curb panels perforated
LOW ROOF HINGED CENTER PANEL "DOOR"	
S1M1HC2FSV	Solid panels
S1M2HC2FSV	Center and Curb panels perforated
MED/HIGH ROOF FIXED CENTER PANEL	
S1M1C1PM	Solid panels
S1M2C2PM	Center and Curb panels perforated
MED/HIGH ROOF HINGED CENTER PANEL "DOOR"	
S1M1HC2PM	Solid panels
S1M2HC2PM	Center and Curb panels perforated
PARTITION WING KITS	
WKC1FDTS	Steel Partition Mounting Kit - Low Roof
WKC1FDTM	Steel Partition Mounting Kit - Mid Roof
WKC1FDTH	Steel Partition Mounting Kit - High Roof



S1 - Solid
Mounts behind driver seat.



M1 - Solid
M2 - Perforated
Center panel. Also available as a hinged door.



C1 - Solid
Mounts behind passenger seat.

Steel partitions are sold as panel kits and wing kits. Please see application chart to confirm the appropriate panel kit and wing kit for your vehicle.



TA1 4-Hook Bar 2" x 12" bar mounts to partition or shelving. Four welded hooks with 2" hanger opening.

PDK1 Steel Partition Door Kit converts M-Series fixed center panel into hinged door with keyed slam latch. Includes two 6" hinges, bulb seal and a slam latch that reduce vibration noise. (Not available for the Transit Connect)

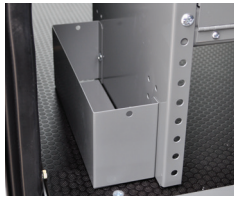

PA9 First Aid Tray secures first aid box. Measures: 11"W, 4-1/2"H, 3-1/8" D

PA7 Reflector Kit w/ Bracket Includes reflector kit with metal pocket holder, I.C.C. approved.



PA8 Fire Extinguisher is a rechargeable, 2-1/2 lb. dry chemical extinguisher. Stops Class A, B and C fires. Complete with charge gauge and mounting bracket.

PA10 File Holder Organizes paperwork. Measures: 12"W, 7"H, 5" D.

TH30 or TH50 Tank Holder holds 30lb. or 50lb. tank to partition or other vertical surface.

Partition Climate Control Kit (not shown) install over the perforations of the partition to help with climate control in the cab.
Low roof: **PA5-1**: S & C panels, **PA5-2**: M panel.
Med & High roof: **PA5-SPR**: S or M or C panels.

Partitions

Transit Connect

NEW COMPOSITE PARTITION FOR TRANSIT CONNECT

Your Transit Connect mobile office is now more comfortable with an Adrian Steel composite partition. Sound deadening reduces driver distractions. Climate control reduces vehicle idle time for warm up and cool down. Generous leg room for less stress behind the wheel. The integrated steel frame provides the same level of performance that you are accustomed to from Adrian Steel.

PARTC - Composite Partition w/ Visibility

PARTC-NW - Composite Partition

UH50RM1 - Accessory Hooks

- Better Climate Control (than perforated partitions.)
- Reduces noise from the cargo area.
- Available with or without a clear poly rear-view window.
- Add hooks along the integrated AD rail.
- Mounting location by the door for a fire extinguisher (not included.)



STEEL PARTITION W/ VISIBILITY

The **P2TCS14** features all steel panels that safeguard the cab area against moving and shifting cargo. The recessed design allows for maximum adjustability of the front seats and provides storage space for a 6 foot step ladder in the back of the LWB Transit Connect. The perforated window allows for visibility of your cargo area and rear windows while the solid steel construction provides better climate control and sound deadening. The steel header and full perimeter wings provide optimal security. Fits 2014 and newer Transit Connect.

PA5-TC14 - Climate Control Panel Kit

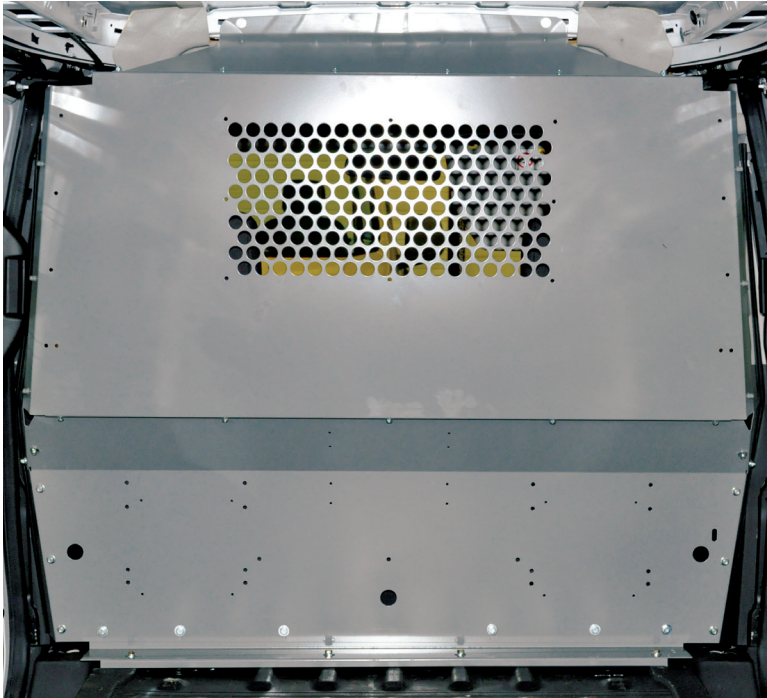

WIRE PARTITION

The **P2TCFW14** provides maximum visibility while safeguarding your van cab area against moving and shifting cargo. The recessed design allows for maximum adjustability of the front seats and provides storage space for a 6 foot step ladder in the back of the LWB Transit Connect. The **P2TCFW14** is lightweight and economical without sacrificing safety and security. Fits 2014 and newer Transit Connect.

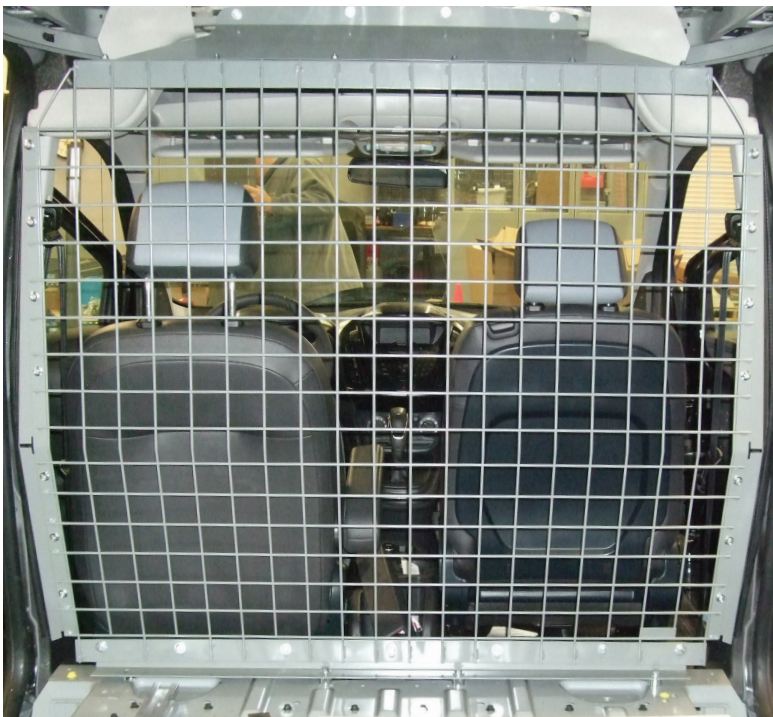



THE NEXT GENERATION OF CARGO MANAGEMENT SOLUTIONS

Tools, equipment and cargo come in all shapes and sizes and until now, there hasn't been a shelving unit that is **truly adjustable**. The ADseries is the first of it's kind where, with only a screwdriver, you can simply remove the front shelf bolts and move the shelf where you need it. Shelves can be adjusted in one inch increments and provide the most flexible shelving solution available.

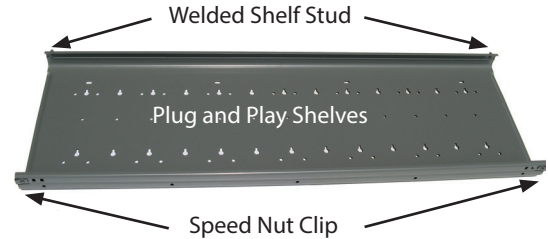
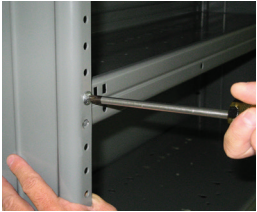

TRULY ADJUSTABLE SHELVES

All you need is a phillips head screwdriver! The unique shelf design features rear shelf studs that lock the shelves in place and speed nut clips that allow you to attach bolt on easily! Simply remove two bolts from the speed nut clips at the front lip of the shelf, tilt the shelf upwards to disengage the rear studs, move the shelf to your desired location, insert the rear shelf studs, reattach the bolts and you're done!



ADAPTABLE INTERIOR

Everyone likes to set their work van up their own way. The ADseries allows you position the shelving where you need it. Exclusive to the ADseries, the unique rail system enables you to reposition the shelving along the rail, increasing the available space for trade specific equipment. All of this is done without removing bolts, plugging holes and redrilling the van! The 6" knock out of the stamped steel end panels (available for the Low Roof Transit) provides a 48" floor space to accommodate 4'x 8' sheet goods (up to 22 sheets of 1/4" drywall or a combination of thicknesses).



ADD ACCESSORIES

Businesses change over time and your van interior should be able to change with your needs. Plug and Play shelves have prepunched holes that allow adding storage solutions easily! ADseries dividers simply snap in place, drawer units and door kits simply bolt into place. Many Adrian Steel accessories can be added to the ADseries shelving with the rail adapter kits and end panel brackets.

MODEL	SIZE	DESCRIPTION
AD32FP	32"W x 46"H x 14"D	fits low roof Transit
AD44FP	44"W x 46"H x 14"D	fits low roof Transit
AD50FP	50"W x 46"H x 14"D	fits low roof Transit
AD1226TC14	26"W x 44"H x 12"D	fits 14-on Transit Connect
AD1426TC14	26"W x 44"H x 14"D	fits 14-on Transit Connect
AD1232TC14	32"W x 44"H x 12"D	fits 14-on Transit Connect
AD1432TC14	32"W x 44"H x 14"D	fits 14-on Transit Connect
RK130FTS	130"WB Rail Kit,	Mounting Rail Kit
RK148FTS	148"WB Rail Kit	Mounting Rail Kit
RK130FTM	130"WB Rail Kit	Mounting Rail Kit
RK148FTM	148"WB Rail Kit	Mounting Rail Kit
RK148FTH	148"WB Rail Kit	Mounting Rail Kit
RKTC14	Mounting Rail Kit	fits 14-on Tr. Connect SWB, LWB
RKDTC14	Mounting Rail Kit	fits 14-on Tr. Connect LWB

MODEL	SIZE/DESCRIPTION
DV14C1	Shelf Divider
DV14C8	14" Shelf Dividers
DV12AD	Shelf Divider
DV14	Shelf Divider
DK26TC	Door Kit
DK32TC	Door Kit
DK3010	Door Kit
DK4208	Door Kit w/ Open Back
DK4210	Door Kit w/ Open Back
DK4810	Door Kit
BRK14EPS	End Panel Mounting Bracket
RKA1	Rail Kit Adapter/See list at right
RKA3	Rail Kit Adapter3/See list at right
RKA4	Rail Kit Adapter4/See list at right
RKAWTR	Welded Tank Rack Rail Adapter
RKA919	Drawer Riser Kit
35325-G	32" Long Shelf
35327-G	44" Long Shelf
35328-G	50" Long Shelf

RKA3 – Rail Adapter Kit3
Use with: #1, #12, #2, #8, DC Units, 17A, TA19, TA5

RKA4 – Rail Adapter Kit4
Use with: 17A, CB5, 43, TA19, WRH5, UH10/50, PA9, PA8, Shelving Units, #33W, JD Shelving

BRK14EPS – End Panel Mounting Bracket
Use with: 17A, CB5, 43, TA19, WRH5, UH10/50, PA9, PA8, ACT3/4, PA7, TH30, TH50, TA5

Note: Rails are not included with the shelf units. Rail kits must be ordered separately.

Note: Shelves have the following weight ratings:

- Shelves positioned with the shelf lip facing up have a rating of 100 lbs. per shelf evenly distributed.
- Shelves positioned with the shelf lip facing down have a rating of 200 lbs. per shelf evenly distributed.

THE NEXT GENERATION OF CARGO MANAGEMENT SOLUTIONS

Tools, equipment and cargo come in all shapes and sizes and until now, there hasn't been a shelving unit that is **truly adjustable**. The ADseries is the first of it's kind where, with only a screwdriver, you can simply remove the front shelf bolts and move the shelf where you need it. Shelves can be adjusted in one inch increments and provide the most flexible shelving solution available.



MODEL	SIZE	DESCRIPTION
AD32FP	32"W x 46"H x 14"D	3-Shelf Unit, 32"
AD44FP	44"W x 46"H x 14"D	3-Shelf Unit, 46"
AD50FP	50"W x 46"H x 14"D	3-Shelf Unit, 50"



HAD SHELVING FOR MEDIUM & HIGH ROOF TRANSIT

The **HAD shelving units** feature two ADseries adjustable shelves in the center of the shelf unit. These two shelves feature a 2" lip and, with only a screwdriver, can be adjusted up or down on one inch increments. Includes two steel back panels and shelves have pre-drilled holes for adding dividers, drawer units and other plug and play accessories. Must be installed with a Rail Kit. See page 8 for the appropriate Rail Kit. (page 10)

MODEL	OVERALL SIZE
HAD3259	32" x 59" x 14"
HAD4459	44" x 59" x 14"
HAD5059	50" x 59" x 14"

HD & JD Shelving

Transit Medium & High Roof



HD SHELVING FOR MEDIUM & HIGH ROOF TRANSIT

The **HD shelving units** feature KD adjustable shelves. The top and bottom shelf feature a 2" lip, the center two shelves feature a 4" lip. Each shelf can be adjusted up or down on one inch increments.

MODEL	OVERALL SIZE
HD4459	44" x 59" x 14"
HD5059	50" x 59" x 14"

JD SERIES JUMBO DEEP SHELVING

- Available in 18" and 24" depths.
 - Shelf gussets and floor rail provide extra strength.
 - 18" deep units contain one 14" and two 18" deep shelves.
 - 24" deep units have squared end panels and two shelves.
- See chart.

MODEL	OVERALL SIZE	OPEN SHELF SPACE
JD42FP	42"W x 46"H x 18"D	14.58 sq ft
JD52FP	52"W x 46"H x 18"D	18.56 sq ft
JD48FP	48"W x 48"H x 24"D	20.21 sq ft
JD60FP	60"W x 48"H x 24"D	20 sq ft

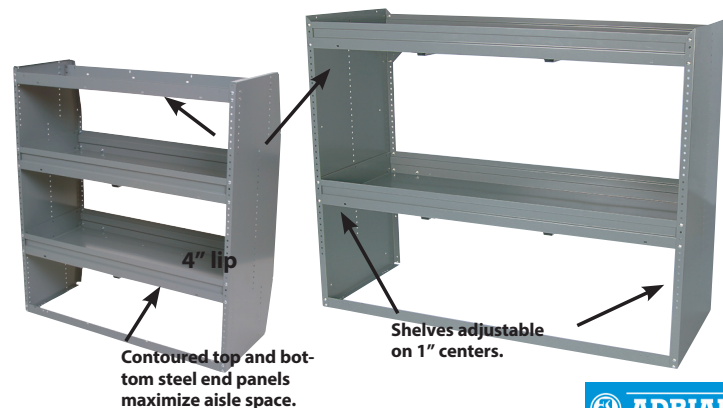

WELDED SHELVING FOR LOW ROOF TRANSIT

The 44 Series Welded Shelving feature welded shelves, back panels and end panels. These fully welded shelf units allow for greater weight capacity and reduce cargo noise. Configure your Transit to your specific needs with drawer units, dividers and removable bins to customize your setup.

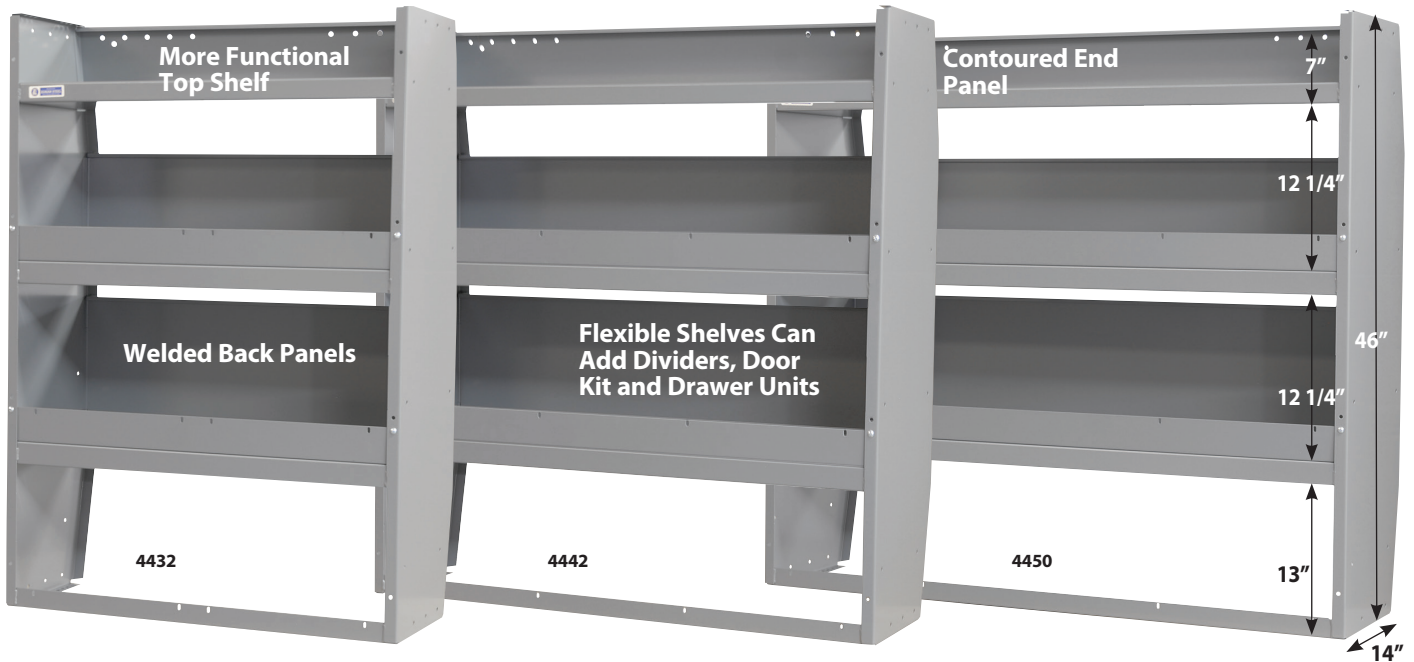

MODEL	DESCRIPTION
4432	Welded 3-Shelf Unit
4442	Welded 3-Shelf Unit
4450	Welded 3-Shelf Unit



Contoured top and bottom steel end panels maximize aisle space.

ACCESSORIES FOR WELDED SHELVING

Upgrade the 44 Series with Dividers, DC Drawer Units, Lock & Latch drawer units, Door Kits and our popular #28 Parts bin!



Plug & Play units – add accessories in minutes!



ACCESSORIES

MODEL	DESCRIPTION
DV44U1	Top Shelf Divider (single)
DV44U4	Top Shelf Divider Kit (4 pack)
DV44U	Top Shelf Divider Kit (8 pack)
DV44L1	Lower Shelf Divider (single)
DV44L4	Lower Shelf Divider Kit (4 pack)
DK532	Door Kit w/ Back Panel
DK544	Door Kit
DK550	Door Kit
28	Parts Bin

- Built to bolt onto the DC6 and DC12, these shelves can provide additional storage space.
- The shelves are available in 18", 24" and 36" wide configurations.
- Feature a 1" shelf lip.



DRAWER COMPONENT SHELVES

- Create customized shelving modules with drawer component shelves.

STORAGE MODULES ARE USEFUL COMBINATIONS OF SHELVING AND STORAGE.

When you need a variety of parts and tools to do the job, it is essential that you have them organized and easily accessible. Offering a variety of storage and workbench combinations, Adrian Steel Modules are the key to efficiency when working out of your van.

MD507 SHELF AND DRAWER MODULE

MD507 INCLUDES:

9	4-Drawer Unit w/ Lock
18	Welded 3-Shelf Unit w/ Dividers
19	2-Drawer Unit w/ Lock
40	Wheelwell Bin w/ Lock
43	3-Shelf Literature Rack

42"W x 46.5"H x 14"D



MD506 SHELF AND DRAWER MODULE

MD506 INCLUDES:

9	4-Drawer Unit w/ Lock
12	Adjustable Single Shelf Cabinet w/Lock (2)
19	2-Drawer Unit w/ Lock
40	Wheelwell Bin w/ Lock
43	3-Shelf Literature Rack

42"W x 46.5"H x 14"D



MD508 WORKBENCH MODULE

MD508 INCLUDES:

9	4-Drawer Unit w/ Lock
19	2-Drawer Unit w/ Lock
40	Wheelwell Bin w/ Lock
60105	Workbench Top

42"W x 26"H x 14/18"D



MD509 WORKBENCH MODULE

MD509 INCLUDES:

8	3-Drawer Unit (2)
40	Wheelwell Bin w/ Lock
60105	Workbench Top
CB2	2-Book File

42"W x 31"H x 14/18"D



WORKBENCH MODULE FOR LOW, MEDIUM & HIGH ROOF

The MD608 Workbench Module features 84" of work top surface perfect for any mobile workshop. Shown with optional 17A 6-Shelf Catalog File and floor Rail Kit. See package 5274TL.

MD608 INCLUDES:

KMB36	Key Machine Base
60105	Workbench Top (2)
9	4-Drawer Unit w/ Lock (2)
19	2-Drawer Unit w/ Lock (2)
40	Wheelwell Bin w/ Lock
14	Step Stool

Storage Modules are designed to fit over wheelwells of the low roof Transit van. Shelving and Modules must be installed on a Rail Kit. See page 6 for the appropriate Rail Kit.

Visit AdrianSteel.com to see more Storage Modules.

SPECIFIC JOBS DEMAND SPECIFIC STORAGE SOLUTIONS.

Cabinet and Drawer Modules provide secure storage for large and small tools and parts. The modular design allows you to get what you need now and the ability to add more when you need it. Whatever the job demands, Adrian has the storage solutions to transport your gear safely and securely.



Vented gas storage solutions

TANK CABINETS

- Provide vented storage for Propane, Mapp gas or CO2 tanks.
- Cabinets feature a full door gasket with two snap latches for positive door closure.
- Interior cabinet cradle and retaining straps (foam yokes for TA19) secure tanks and prevent movement.
- Floor vent and tubing are included for exhausting fumes.
- Propane cabinets store 20, 30 or 40 lb. tanks.
- Mapp Gas Cabinets store 6 1/2" diameter tanks.
- CO2 Tank Cabinets store 20 lb. cylinders.

MODEL	DESCRIPTION	CABINET SIZE
TA19	Compressed Gas Tank Cabinet	13"W x 32"H x 12-1/2"D

SHELF CABINETS

- Available in 12" and 18" front to rear lengths
- Can be used free standing or stacked with our lockable drawer units.
- Feature locking recessed tee-handles for secure storage and receive a durable gray powder coat finish.
- Cabinets feature an open side and can be combined for side-by-side use holding items up to 35" long.
- Optional end panel can be added to close off side when required.
- Include an adjustable shelf that can be removed
- Cabinets provide a solid surface to stack modular drawers, cabinets and bins.



Folding T handles don't stick out into aisles.

MODEL	DESCRIPTION	CABINET SIZE
1	Adjustable Single Shelf Cabinet w/Lock	18"W x 22"H x 18"L
12	Adjustable Single Shelf Cabinet w/Lock	18"W x 22"H x 12"L
1A	Cabinet Shelf	No. 1
12A	Cabinet End Panel	No.12
12B	Shelf	No.12



40 WHEEL WELL COVER CABINET

- Wheel well cover cabinets are designed with an open back and bottom.
- Serves as an enclosure for rear wheel wells.
- Provides a solid surface to stack modular drawers, cabinets and bins.
- Cabinets come with locking recessed tee-handles for secure storage.
- Finished with a durable gray powder coat finish.
- Cabinet size 42"W x 12.5"H x 14"L



CL1446R

CABINET LOCKERS

- Full-door Lockers feature a 46" high storage space with 3 removable shelves.
- Locker doors are reversible for flexibility and feature locked recessed T-handles for security.
- Cabinet Lockers taper from 14" to 12" from front to back in depth at top and bottom to maximize aisle space.

MODEL	DESCRIPTION	CABINET SIZE
CL1446R	Adjustable 3-Shelf Cabinet w/ Lock	18"W x 46"H x 14"D



2.5" deep drawers come with ABS divided and removable trays perfect for small parts.

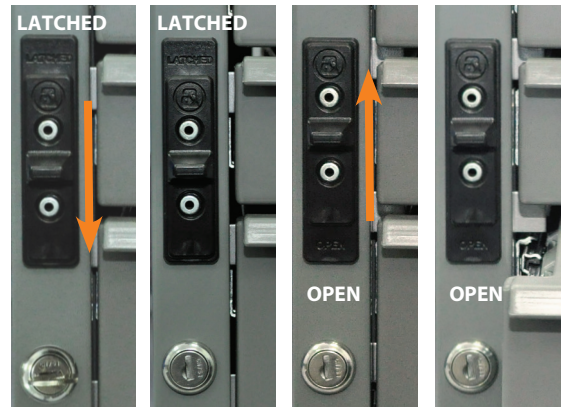

DRAWER UNITS – LOCK 'N LATCH SYSTEM

- Our exclusive Lock 'n Latch system provides a choice of drawers open, drawers retained or drawers locked position.
- Drawers are made of an engineered composite material for durability with heavy-duty drawer glides for support and smoother drawer operation.
- The new drawer glides significantly increase the ease of use when opening and closing the drawer units. They all but eliminate the rattle noise of the drawers when the driving the vehicle.
- Drawers and glides can be repositioned within cabinet for increased flexibility.
- Divide 5" deep drawers into compartments using optional metal "egg crate" dividers.

MODEL	DESCRIPTION	DRAWER SIZE (QTY.)
19	2-Drawer Unit w/ Lock	16"W x 5"D x 11-1/2"L (2)
919	3-Drawer Unit w/ Lock	16"W x 2-1/2"D x 11-1/2"L (2) 16"W x 5"D x 11-1/2"L (1)
9	4-Drawer Unit w/ Lock	16"W x 2-1/2"D x 11-1/2"L (4)
27	Drawer Divider Assembly	19 or 919 Drawer (1)

Steel outer cabinet measures 18"W x 12"H x 12"L.

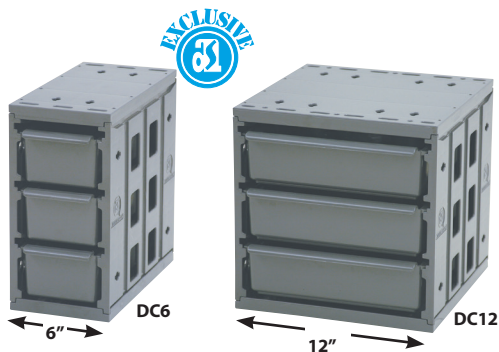

DRAWER COMPONENTS

- Organize small parts with our flexible and rugged composite Drawer Components.
- Drawer retention stops prevent drawers from opening while the vehicle is in transit.
- Made of a hi-impact polymer for a quiet operation.
- Each drawer comes with 2 dividers and 7 divider slots.
- Interlocking feature allows up to 2 units stacked vertically or multiple units horizontally.
- Choose from Adrian Steel's pre-configured drawer systems or create your own drawer system from the base models.

MODEL	DESCRIPTION	OVERALL SIZE
DC6	3-Drawer Unit	6"W x 12"H x 12"D
DC12	3-Drawer Unit	12"W x 12"H x 12"D

5lb. weight capacity per drawer.



#2 Cabinet Size
18"W x 24"H x 18"L

#8 Cabinet Size
18"W x 18"H x 12"L

DRAWER UNITS – LOCKING HINGE AND HASP

- Drawers are welded and have reinforced drawer slides for strength.
- Can be locked with a padlock (not included) for security.
- Divide drawers with optional metal "egg crate" dividers.

MODEL	DESCRIPTION	DRAWER SIZE (QTY.)
8	3-Drawer Unit	16"W x 5"D x 11-1/2"L (3)
2	4-Drawer Unit	16"W x 5"D x 17-1/2"L (4)

BE MORE EFFICIENT WITH INVENTORY THAT IS READY TO GO WHEN AND WHERE YOU ARE.

Versatile, lightweight, durable, convenient and mobile - these **Portable Parts Cases** are perfect for the tech who needs to carry small parts and inventory to the jobsite.

The impact resistant body can be organized with the included adjustable dividers. The see-through lids with snap latches make identifying contents easy.

PPCS 14" x 14" x 3.75"

PPCL 14" x 14" x 6.25"



CH-EP
15.5" x 11.25" x 37.5"

* FIRST AID KIT
NOT INCLUDED
(#15372-0)



CHPPC5SM
16.5" x 14" x 35"



Add a single **CH1514SGL** 15" x 14" x 12" or double **CH-1514DBL** 15" x 14" x 12" **Case Holder** to an existing shelf to house included cases that stay put while in transport.

INCORPORATE THE PORTABLE PARTS CASES INTO YOUR VAN WITH THE STORAGE OPTION THAT FITS YOUR NEED.

Three different **Case Holder** options give you the ability to house multiple Portable Parts Cases near the vehicle door for easy access to grab-and-go. The **CH-EP** and **CHPPC5SM** include a tray that holds an optional first aid kit and feature slanted shelves.

The **CHPPC4S** includes four PPCS cases and each shelf has a retaining lip to keep cases in place.



CHPPC4S
14 3/8" x 14 3/8" x 18"

A CENTER CONSOLE DESK KEEPS ELECTRONICS SECURE AND OUT OF SIGHT.

Designed to be mounted in the cab, between the front seats.



Tech Desk Console for Ford Transit

- Designed to mount between the front seats.
- 2 USB Ports.
- Non-Slip lid tray to keep items from falling off during transit.
- Internal Organization.
- Lockable Lid.
- Interior LED lights.

TDC6 Tech Desk Console - Fits Ford Transit, up to 2020

TDC9 Tech Desk Console - Fits Ford Transit, 2021 and on



Center Console Desk for Ford Transit

- Designed to mount between the front seats.
- Rugged steel construction with a hinged worktop and key locking paddle handle.
- Convenient lid mounted clip holds papers in place on the writing surface.
- Center Console Desks mount securely to the vehicle floor, and can be removed for service.
- Measures 6.7"W, 18.3"H, 22.3"D

CCD6 Center Console - Fits Ford Transit, up to 2020

CCD9 Center Console - Fits Ford Transit, 2021 and on

CCDHF6 Center Console Hanging File

CCDHF9 Center Console Hanging File

LITERATURE FILES



1: CB5 5-Slot Literature Rack Mount on partition or other vertical surface. 2-1/2" deep pockets. Overall size: 12"W, 24"H, 2-1/2"D.

2: CB7 7-Slot Literature Rack Mount on partition or other vertical surface. 6-3/4" deep pockets. Overall size: 14-3/4"W, 28-7/8"H, 7"D.

3: 17A 6-Shelf Catalog File Designed for catalogs but also serves to store a variety of materials between the 3" shelf spacings. Overall size: 11"W, 24"H, 12"D.

4: 43 3-Shelf Literature Rack Fits in narrow spaces. It has three tilted shelves. Perfect for binders and catalogs. Overall size: 6" W, 34" H, 12" D.

5: BH4 4-Slot Literature Rack Designed to mount on partition or almost any vertical surface. Excellent for binders. Each pocket is 2 1/2" deep. Overall size: 12-3/4" W, 19-1/2" H, 2-1/2" D.

ADRIAN'S FLOOR DRAWER IS THE FINEST FLOOR STORAGE UNIT YOU CAN BUY.

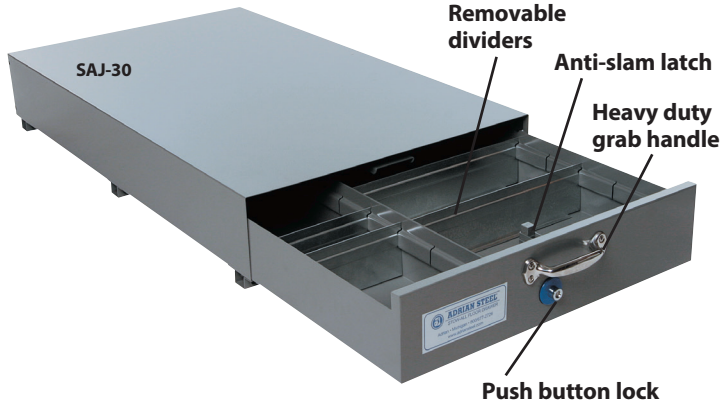

- 14 Gauge steel outer cabinets are constructed with top channel cross support members for strength and rigidity.
- Drawers are constructed with double sidewalls to prevent bowing and to accommodate items up to 48" in length.
- The anti-slam latch stops drawers from completely closing without positive latch activation.
- Heavy-duty grab handle and push button lock allows for comfortable, one-handed drawer operation.
- Durable powder coat finish will provide years of rugged service.
- Easy glide drawers with full width recessed conveyor roller at front and hardened steel roller bearings at rear.
- Install at rear or side doors, and units can be stacked.

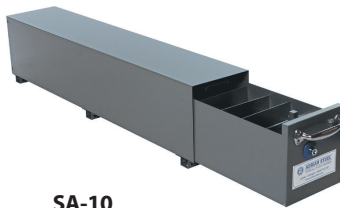

SA-10

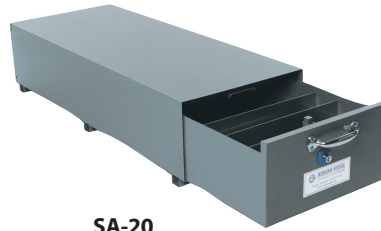

SA-20



SA-40

FLOOR DRAWER DEEP SERIES

MODEL	DESCRIPTION	CABINET SIZE	DRAWER SIZE	DIVIDER (QTY.)
SA-10	Single Compartment Floor Drawer	10"W x 12"H x 51-1/2"D	9-5/8"W x 8-1/2"H x 48-1/2"D	DV9(5)
SA-20	Single Compartment Floor Drawer	20"W x 12"H x 51-1/2"D	19-5/8"W x 8-1/2"H x 48-1/2"D	DV19(5)
SA-40	Triple Compartment Floor Drawer	40"W x 12"H x 51-1/2"D	9-5/8"W x 8-1/2"H x 48-1/2"D (2) 19-5/8"W x 8-1/2"H x 48-1/2"D	DV9(10) DV19(5)

Floor Drawer Dividers are available and are sold individually.



SAJ-10



SAJ-20



SAJ-30

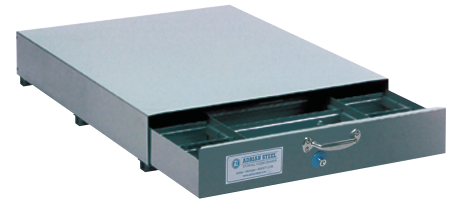

SAJ-40

FLOOR DRAWER SHALLOW SERIES Floor Drawer quality in a lower profile

MODEL	DESCRIPTION	CABINET SIZE	DRAWER SIZE	DIVIDER (QTY.)
SAJ-10	Single Compartment Floor Drawer	10"W x 8-1/2"H x 51-1/2"D	9-5/8"W x 5-1/4"H x 48-1/2"D	DVJ9(5)
SAJ-20	Single Compartment Floor Drawer	20"W x 8-1/2"H x 51-1/2"D	19-5/8"W x 5-1/4"H x 48-1/2"D	DVJ19(5)
SAJ-30	Double Compartment Floor Drawer	30"W x 8-1/2"H x 51-1/2"D	9-5/8"W x 5-1/4"H x 48-1/2"D 19-5/8"W x 5-1/4"H x 48-1/2"D	DVJ9(5)
SAJ-40	Triple Compartment Floor Drawer	40"W x 8-1/2"H x 51-1/2"D	9-5/8"W x 5-1/4"H x 48-1/2"D (2)	DVJ9(10)

REEL HOLDERS

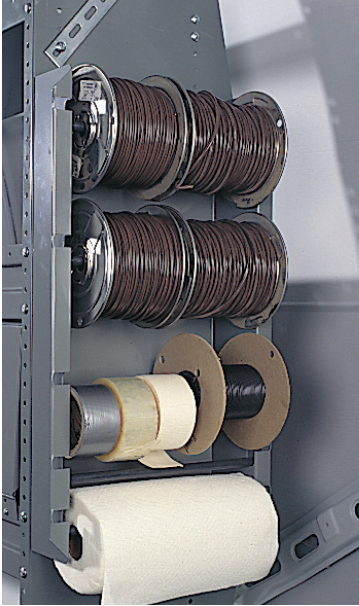

WRH5 5-Bar Spool Holder Five removable bars hold wire spools up to 6" in diameter. Reel Holder mounts to shelf ends or any vertical surface. Overall size: 12" W, 25" H, 4" D

WIRE WINDOW SCREENS

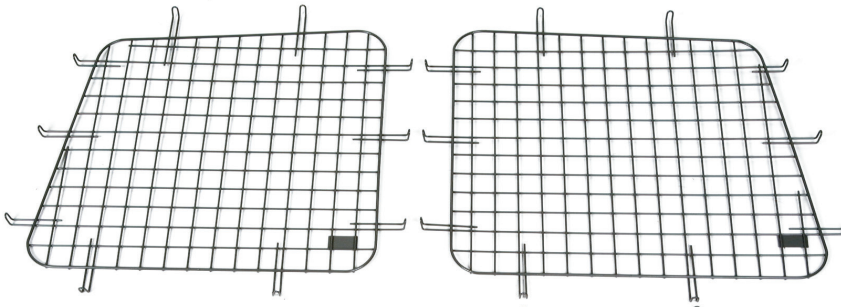

Wire Window Screens add security to cargo area windows. Contoured to fit the window and feature a non-glare gray powder coat finish.

Transit Low Roof:

- 60-134** Passenger Side Rear Door Security Screen
- 60-135** Driver Side Rear Door Security Screen
- 60-138** Passenger Side Sliding Door Security Screen
- 60-140** Passenger Side Door Security Screen
- 60-141** Passenger Side Door Security Screen
- 60-TRLHDRD** Passenger Side Hinged & Rear Doors Security Screen Kit
- 60-TRLRDR** Rear Doors Security Screen Kit
- 60-TRLSDR** Passenger Side Sliding & Rear Doors Security Screen Kit

Transit Mid & High Roof

- 60-132** Passenger Side Rear Door Security Screen
- 60-133** Driver Side Rear Door Security Screen
- 60-136** Passenger Side Sliding Door Security Screen
- 60-TRMHRDR** Rear Doors Security Screen Kit
- 60-TRMHSDR** Passenger Side Sliding & Rear Doors Security Screen Kit

Transit Connect:

- 60-TC14RB** Rear Doors Security Screen Kit
- 60-TCS14S** Sliding Doors Security Screen Kit
- 60-TCL14S** Sliding Doors Security Screen Kit

ADRIAN'S BLUE BIN SYSTEM IS PERFECT FOR VISUAL INVENTORY MANAGEMENT.

- 6" and 12" bins maximize the ADseries shelf space.
- The bins can nest on top of each other when at the job site or in the warehouse getting filled to go.
- Add a label to the front so you can find parts quickly
- Each bin can accommodate one optional divider.

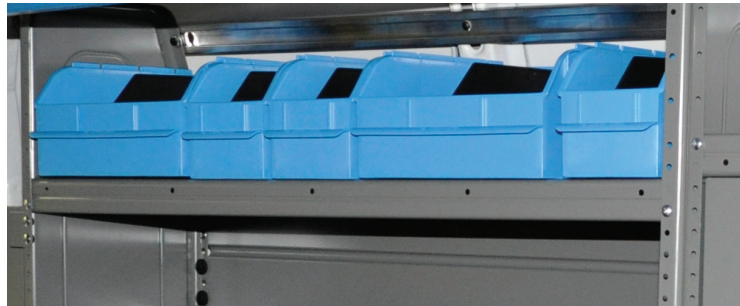
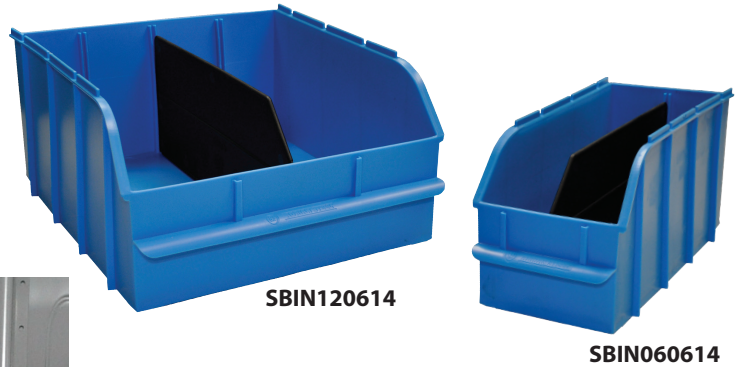

MODEL	DESCRIPTION
SBIN060614	Snap In Bin
SBIN120614	Snap In Bin Divider
SBINDIV	Snap In Bin Divider

BURCO S-SERIES GLASS RACKS FIT THE FORD TRANSIT AND ARE ADAPTABLE TO YOUR NEEDS.



The 45047 Burco Glass Rack accommodates up to 11 windshields. Designed for modern windshields with six 14.5" and six 23.5" divider posts. The glass rack can transport both taller windshields and smaller glass panels safely and are ideal for loading and unloading glass from the top or side. Each post is surrounded with a protective foam cover and a twist and lock top to keep your glass safe and secure. Fits Ford Transit.

SAFELY TRANSPORT REFRIGERANT TANKS IN AN ADRIAN STEEL TANK RACK.



Safely carry 30-lb. and 50-lb. refrigerant tanks securely in your van. Tank Racks can be installed for easy access from the side or rear van doors for increased ergonomics and reduced risk of injury. For customers with a high roof van, these products can be stacked to carry more tanks by using the vertical space in you van.



MODEL	DESCRIPTION	HOLDS
TR330	Tank Rack, 3 (30lb)	Three 30lb. tanks
TR230150	Tank Rack, 2 (30lb), 1 (50lb)	Two 30lb. & one 50lb. tanks
TR350	Tank Rack, 3 (50lb)	Three 50lb. tanks
TR430	Tank Rack, 4 (30lb)	Four 30lb. tanks
TRSHELF30	4" Shelf for 30lb racks	
TRSHELF50	4" Shelf for 50lb racks	

*Please confirm the location of the tank rack and tray, some interior locations will not accommodate the tray due to the contour of the vehicle.



1



2



3

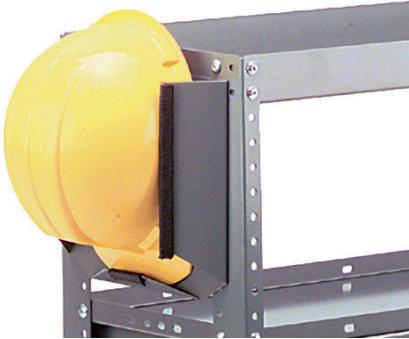

4

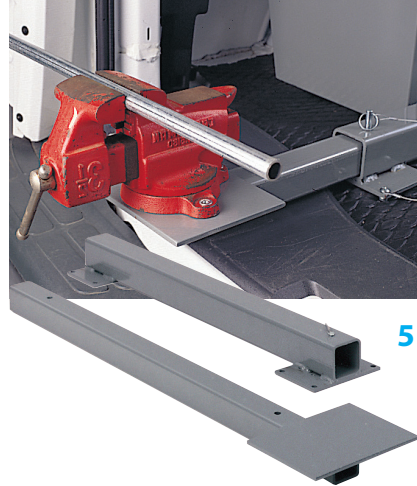

5



6

1: DST21 Door Storage Tray offers convenient access to parts and tools.

Overall size: 20" W, 4" D, 8" H

2: Aerosol Can Tray secure cans for easy access.

ACT3 - 3-Place Aerosol Can Holder

ACT4 - 4-Place Aerosol Can Holder

3: 14 Step Stool has a wide base and is 12" high. Stool can be used with a workbench or as an auxiliary step. Top measures 10" x 20" One size.

4: TA2 Hard Hat Holder secures hat to partition or shelving.

5: VMA36 Vise Mount Assembly is floor mounted and telescopes out beyond side or rear cargo doors when fully opened. Measures 36" closed and 60" open.

6: Touch-Up Paint in spray cans match Steel-Cote™ finish. Three colors:

STP12G - Gray **STP12W** - White **STP12B** - Black

7: Door Tray comes with two dividers and has optional lid for containment.

DT21 - Door Tray Overall size: 18" W, 4" D, 4" H

DTL21 - Door Tray Lid for DT21 only

DTWL21 - Door Tray w/ Latching Lid

8: Hooks organize a variety of cargo in easy-to-access locations.

UH10 - Utility Hook

UH25 - Utility Hook

UH50 - Utility Hook

TA1 - 4-hook bar

9: Parts Tray features a 2" deep shelf lip. Can be mounted to cabinet and drawer modules for added top storage.

4B - Parts Tray Overall size: 18" W, 12" D, 2" H



Storage for small parts 7

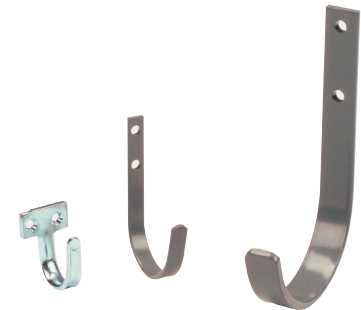

8



9

FINALLY!

A LADDER RACK DESIGNED AROUND YOU... NOT YOUR VEHICLE.

Introducing the All-New Drop-Down Ladder Rack from Adrian Steel!



The new, simpler design makes it easier to install and adjust. The aluminum build of the rack reduces corrosion and keeps your ladder rack looking like new. It will accommodate a variety of ladders and safely secure them for transport.

Technicians that are 5'-4" or taller can safely load and unload the ladder because of the lower, more ergonomic load and unload height. Durability testing ensures that the rack will stand the test of time and perform as it should for many years.



EXCLUSIVE!

With the turn of a knob, you can quickly adjust the rack to fit a wide variety of ladders.

- DDLR61FTL** - Passenger Side Drop Down Ladder Rack
- DDLR63FTL** - Double Drop Down Ladder Rack
- DDLR64FTL2** - Drop Down & Grip Lock Combo Rack (shown above)
- DDLRSLK2** - Adjustable Step Ladder Kit
- 70-1LR** - Conduit Kit w/ Round End Caps
- 70-2LR** - Conduit Kit w/ Round End Caps
- 80-1LR** - Aluminum Conduit Kit, 10'6"
- 80-2LR** - Aluminum Conduit Kit, 12'6"

Technicians that are 5'-4" or taller can easily load and unload the rack without climbing up on anything.



Standard rack accommodates 28' extension ladder and 10' step ladder – short step ladders will need optional step ladder kit and up to 32' extension ladder with extension ladder kit.

See it in action on AdrianSteel.com

FINALLY!

A LADDER RACK DESIGNED AROUND YOU... NOT YOUR VEHICLE.

Introducing the All-New Drop-Down Ladder Rack from Adrian Steel!



Our most user friendly ladder rack ever! Featuring the patent pending twist to adjust! The fastest way to adjust your rack to your ladder! The outboard design and two stage drop brings ladder down to an ergonomic load position where operators 5' 4" or taller can safely load and unload the ladder. The aluminum build of the rack reduces corrosion and keeps your ladder rack looking like new. Adrian Steel's Drop-Down Ladder Rack will accommodate a variety of ladders and safely secure them for transport.



EXCLUSIVE!

With the turn of a knob, you can quickly adjust the rack to fit a wide variety of ladders.

- DDL61FTM** - Passenger Side Drop Down Ladder Rack, Mid Roof
- DDL63FTM** - Dual Sided Drop Down Ladder Rack, Mid Roof
- DDL61FTH** - Passenger Side Drop Down Ladder Rack, High Roof
- DDL63FTH** - Dual Sided Drop Down Ladder Rack, High Roof
- DDL6SLK2** - Adjustable Step Ladder Kit, Mid Roof
- DDL6SLKHR** - Adjustable Step Ladder Kit, High Roof



Technicians that are 5'-4" or taller can easily load and unload the rack without climbing up on anything.

We know different jobs require different ladders. The new Drop-Down ladder rack safely transports all different types of ladders. Extension ladders, step ladders and specialty ladders. Standard rack accommodates 28' extension ladder and 10' step ladder – short step ladders will need optional step ladder kit and up to 32' extension ladder with extension ladder kit.

See it in action on AdrianSteel.com

ALL-NEW & COMPLETELY REDESIGNED ALUMINUM GRIP-LOCK RACK

Off-the-Roof, Angled Design Offers a Lower Reach Height than Traditional Grip-Lock Racks.

The innovative "tilt angle" design offers a lower reach height than traditional grip lock racks.



Technicians that are 5'-7" or taller can easily load and unload the rack without climbing up on anything.

Adrian Steel's completely redesigned grip-lock style ladder rack is designed to make your job easier when loading and unloading your ladders. The innovative "tilt angle" design offers a lower reach height than traditional grip lock style racks. Technicians that are 5'7" or taller can safely load and unload ladders without having to climb up on something.

The clamping mechanism secures and protects ladders when they are stowed or in transit. A padlock can be added for extra security. The natural aluminum finish reduces corrosion and helps preserve the integrity of the rack.

The all-new Grip-Lock Ladder Rack is an economical option that will look great and perform effortlessly for many years on your van!



- 61-GLFTL2 - Single Grip Lock Ladder Rack
- 63-GLFTL2 - Double Grip Lock Ladder Rack
- 64-GLFTL2 - Double Grip Lock Ladder Rack w/ Step Ladder Kit
- GLSLKFSV - Step Ladder Kit
- 70-1LR - Conduit Kit w/ Round End Caps
- 70-2LR - Conduit Kit w/ Round End Caps
- 80-1LR - Aluminum Conduit Kit, 10'6"
- 80-2LR - Aluminum Conduit Kit, 12'6"

See it in action on AdrianSteel.com

GRIP YOUR LADDERS SECURELY WITH ADRIAN'S LOCKING STYLE LADDER RACKS.

Adrian's Grip-Lock racks protect the sides and roof of your van during loading and unloading ladders. All Grip-Lock racks feature a lockable, gripping mechanism which firmly secures one or two ladders to the top of the van. Racks easily adjust for ladders of different sizes.

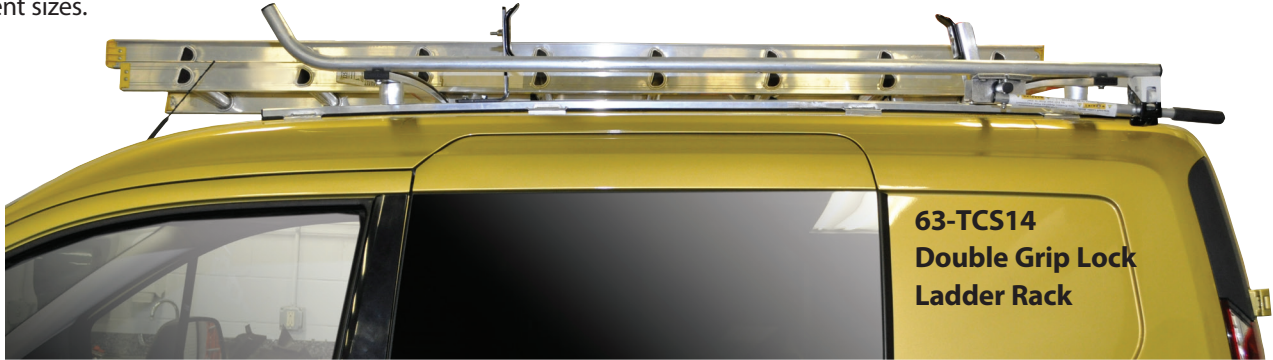

**63-TCS14
Double Grip Lock
Ladder Rack**

TRANSIT CONNECT GRIP-LOCK RACK FEATURES AND BENEFITS

- Heavy-Duty actuating arm firmly grips ladder rungs to prevent shifting of ladder on rack.
- Gripping mechanism is lockable.
- Composite extrusions on front and rear crossbows and uprights protect ladders.
- Rung grips easily adjust to accommodate different types of ladders.
- Features an all aluminum design with a natural aluminum finish.
- There are no straps to deal with, clamping of ladder is automatic.
- Accommodates 24 ft. extension ladder on the SWB and a 28 ft.* extension ladder on the LWB.
- To carry a 6 ft. step ladder on the LWB only, order 1BTCGL14.

2014 TRANSIT CONNECT & NEWER GRIP-LOCK LADDER RACKS

- | | |
|-----------------|-------------------------------------|
| 61-TCS19 | Single Grip Lock Ladder Rack |
| 63-TCS19 | Double Grip Lock Ladder Rack |
| 61-TCL19 | Single Grip Lock Ladder Rack |
| 63-TCL19 | Double Grip Lock Ladder Rack |

2014 TRANSIT CONNECT & NEWER 2 BAR ALUMINUM UTILITY RACK (NOT SHOWN)

- | | |
|----------------|---------------------------|
| 2BTC19 | 2-Bar Utility Rack |
| 2BTCL19 | 2-Bar Utility Rack |



**63-TCL19
Double Grip-Lock on a
LWB Transit Connect**

*Note: This rack can accommodate 28 ft. extension ladders with extra length extending off the rear of the vehicle for balance. Check with local regulations regarding rear overhang of loads.



LADDER KEEPER

- Designed to be loaded from outside the vehicle with a spring loaded clamp.
 - Clears your aisle space by getting your ladder off the floor.
- LK8FT** fits 130"WB Transit, Low and Medium roof, and can carry up to a 6 ft. ladder.
LK8FT148 fits 148"WB Transit, Low, Medium and High roof, and can carry up to a 8 ft. ladder. (Does not fit 148EXT WB.)



ILR - INTERIOR LADDER

OUT OF THE WAY, BUT NEVER OUT OF REACH.

When you transport your ladders within the cargo area of your van, you reduce the wear and tear on the ladder, and on yourself with easy to access and operate ladder storage solutions.

- Customers will appreciate your use of clean, well taken care of equipment rather than bringing the outside mess into their home.

Adrian Steel PROFILE™ HD Utility Rack.

The perfect rack for your business.

Select a pre-configured rack developed for common industry needs or take charge and build your own with our configuration tool.

This new system is low profile, aerodynamic, lightweight & tough. The clean, simplistic and corrosion resistant construction with stainless steel hardware and durable powder-coat finish is built to withstand heavy use and ensure years of dependability.

Mix and match components and accessories give you the flexibility to get the perfect rack for your business in less time and with less hassle.

Designed to adapt to almost any vehicle (truck, trailer and topper mounting coming soon) and the unique modular design can be easily upgraded for specific utility use.

1. Minimalistic Design.

Sleek, low-profile for great looking integration on any vehicle and was specifically designed and tested to prevent wind noise.



2. Safe, Secure Loading.

Multiple integrated tie-down points come standard for quick and safe transportation.



3. Rugged Wear Strip.

Why let loading and unloading take a toll on your gear and rack systems? Our new, extra-thick Wear Strip comes standard to protect equipment and T-slot crossbars, while keeping debris out of the channels.

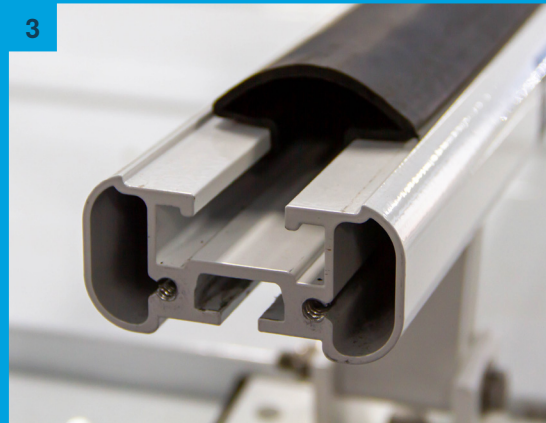

4. Industry-Leading Customization.

Profile™ Crossbars have built-in channels for adding Ladder Stops, Rear Roller Assist, Built-In Ratchets, Conduit Kits and additional accessories.



5. 750lb. Load Capacity.

3" x 1.5" Heavy Duty, reinforced extruded aluminum crossbars are tested to support up to 250LBS per crossbar for maximum roof loading capacity.

(Always follow OEM roof rating weight standards for safest loading capacity)





MADE IN USA



Spec & Tech:

PROUDLY MADE IN THE U.S.A.

Rust-free construction with aluminum and galvanized steel components and stainless-steel hardware.

Simple no-drill installation secured to factory mounting points or drip rails

500LB - 750LB (2 or 3 crossbars) weight capacity. Always follow OEM recommended roof rating standards.

Long lasting DURA™ Powder-Coat Finish in TRU white.

30 minute installation time. (Varies by configuration)

One Rack, Endless Configurations.
Build the perfect rack for your business.

Rear Roller Assist
FULL-SIZE VANS ONLY

Single Crossbar Add-On

68" Crossbars FULL-SIZE VANS
58" Crossbars COMPACT VANS

Ladder Stop

4" Upright

6" Upright

9" Upright

9" Ratchet Upright

More Profile™ Functions Coming Soon!

- Drop Down with EZ-up Technology
- Perimeter Side Rails
- GripLoc®

6" End Caps for PVC Kit
70-2NGLR

4" End Caps for PVC Kit
70-1NGLR

12'6" Aluminum Conduit Kit
80-2NGLR

10'6" Aluminum Conduit Kit
80-1NGLR

The perfect rack for your business.

Select a pre-configured rack developed for common industry needs or take charge and build your own with our configuration tool.

1 **2-BAR OPTIONS**

How to Order: "2-Bar Part Number" + "4-Pack Mounting Kit"



2-Bar w/ 4" Uprights

Full-Size Van #	Compact Van #
2B4W	2B4CW



2-Bar w/ 6" Uprights

Full-Size Van #	Compact Van #
2B6W	2B6CW



2-Bar w/ 9" Ratchet Uprights

Full-Size Van #	Compact Van #
2B9RW	2B9RCW

1 **3-BAR OPTIONS**

How to Order: "3-Bar Part Number" + "4-Pack Mounting Kit" + "2-Pack Mounting Kit"

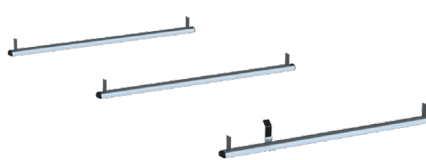

3-Bar w/ 4" Uprights

Full-Size Van #	Compact Van #
3B4W	N/A



3-Bar w/ 6" Uprights

Full-Size Van #	Compact Van #
3B6W	N/A



3-Bar w/ 9" & 9" Ratchet Uprights⁽⁴⁾

Full-Size Van #	Compact Van #
3B9RW	N/A



3-Bar w/ 6" Uprights & Rear Roller

Full-Size Van #	Platform:
3B6RRFTW*	Transit

*Does not work with Transit High Roof 148" Extended or Sprinter High Roof 170" Extended

2 **3** **MOUNTING BRACKETS**

	4-Pack	2-Pack	Vehicle Platform:
Ford	FTMBK4W	FTMBK2W	Transit Low Roof
	FTMBK4W	FTMBK2W	Transit Mid/High Roof
	TCMBK4W	TCMBK2W	Transit Connect

What to order:	1	2	3
2-Bar Rack:	2-Bar Rack part number	+	4-Pack part number
3-Bar Rack:	3-Bar Rack part number	+	4-Pack part number + 2-Pack part number

Scan
to view
racks.



Scan to
build your
own rack.



Scan to
find your
distributor.





A SAFER, MORE EFFICIENT LAST MILE LIFESTYLE



Sliding Partition

- Easy open door with quick access to cargo area.
- Reduces climbing in and out of the van by half.
- Barrier that helps protect the occupants from shifting cargo



Folding Shelves

- Flexible storage for a variety of package sizes
- Strong lightweight aluminum shelves to maximize payload
- Gas struts quiet the shelving while reducing strain of moving shelves up or down.
- 20" deep with 2" lip and available in 36", 48", 60" and 72" lengths



Steps (Rear & Side Doors)

- Slip resistant platform for sure footing.
- Grated platform allows dirt and water to drain through preventing build-up.
- Safely enter/exit van with steps that reduces height to climb in out of the van.



Grab Handles (Rear & Side Doors)

- Helps maintains balance when entering/leaving the vehicle
- Reduces fatigue of climbing in and out of the vehicle
- Point on contact in case of slip trip or fall

Transit Mid & High Roof 148"

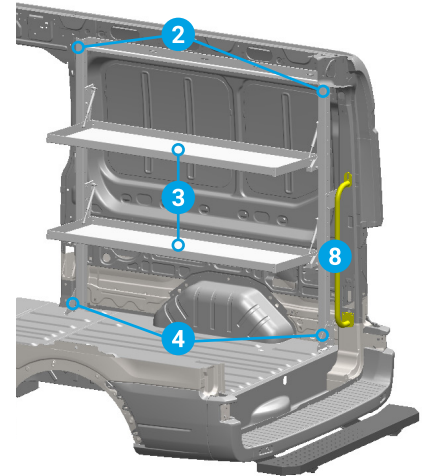
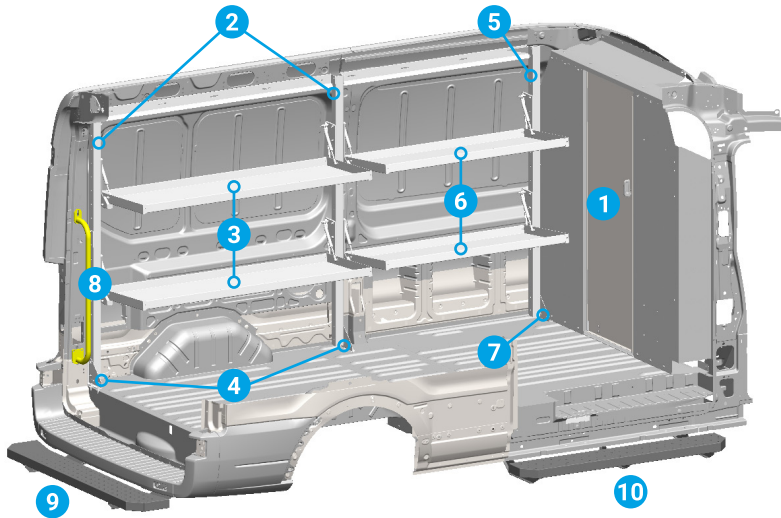

Item:	Description:	Part Number:	Qty:
1	Sliding Partition	SPARFTM (Mid) SPARFTH (High)	1
2	Post Mounting Kit	FSFPKMH	2
3	Folding Shelf Kit, 20 x 60	FSFK2060 *	2
4	Shelf Mounting Kit	FSFMKFT *	2
5	Post Mounting Kit Add-On	FSFPKMHA	1

Item:	Description:	Part Number:	Qty:
6	Folding Shelf Kit, 20 x 48	FSFK2048 *	1
7	Shelf Mounting Kit Add-On	FSFMKFTA	1
8	Grab Handle	GHFT	2
9	Rear Step	STEPFTRD	1
10	Side Step	STEPFTSD	1

* Part number comes as a 2 pack.

Transit High Roof 148" Extended

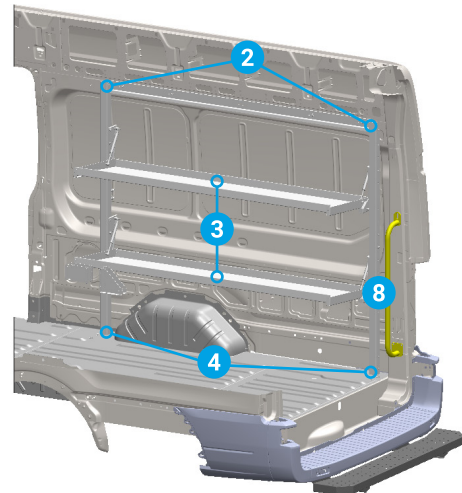
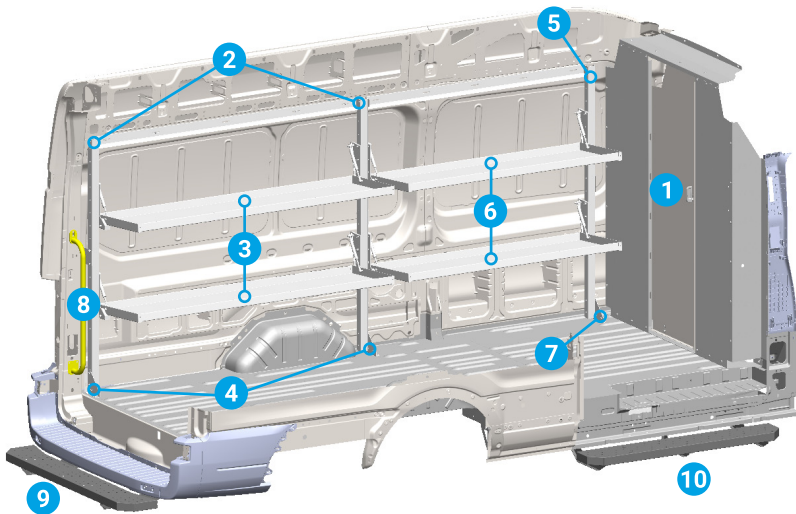

Item:	Description:	Part Number:	Qty:
1	Sliding Partition	SPARFTH	1
2	Post Mounting Kit	FSFPKMH	2
3	Folding Shelf Kit, 20 x 72	FSFK2072 *	2
4	Shelf Mounting Kit	FSFMKFT *	2
5	Post Mounting Kit Add-On	FSFPKMHA	1

Item:	Description:	Part Number:	Qty:
6	Folding Shelf Kit, 20 x 60 *	FSFK2060	1
7	Shelf Mounting Kit Add-On	FSFMKFTA	1
8	Grab Handle	GHFT	2
9	Rear Step	STEPFTRD	1
10	Side Step	STEPFTSD	1

* Part number comes as a 2 pack.

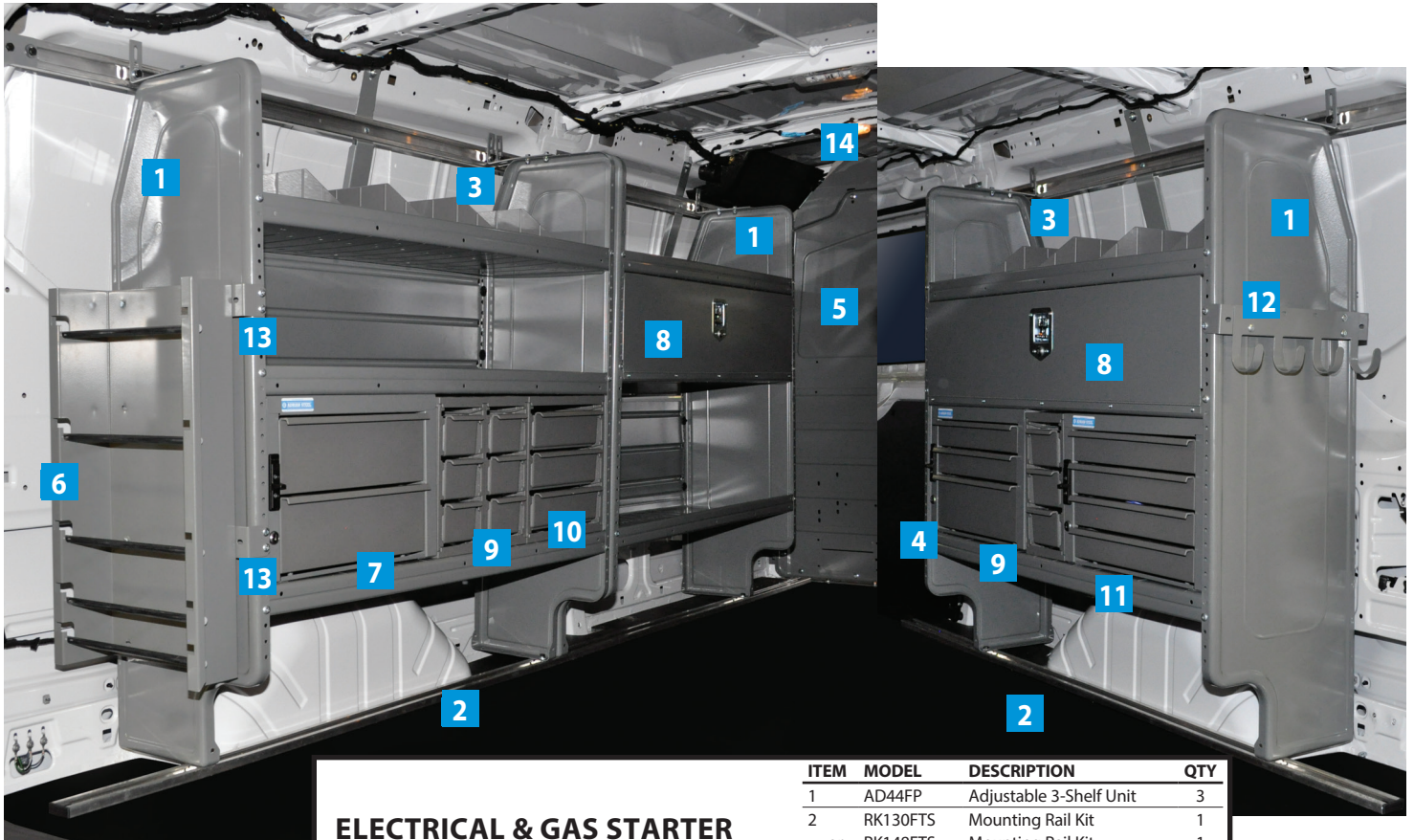

ELECTRICAL & GAS STARTER PACKAGE

4319TL130 Transit 130"WB Low Roof
4319TL148 Transit 148"WB Low Roof

ITEM	MODEL	DESCRIPTION	QTY
1	AD44FP	Adjustable 3-Shelf Unit	3
2	RK130FTS or RK148FTS	Mounting Rail Kit	1
3	DV14C8	14" Shelf Dividers	1
4	919	3-Drawer Unit w/ Lock	1
5	S1M2HC2FSV	Steel Partition Panel Kit w/ Visibility & Door Kit	1
6	WRH5	5-Bar Spool Holder	1
7	19	2-Drawer Unit w/ Lock	1
8	DK4208	Door Kit w/ Open Back	2
9	DC6	3-Drawer Unit	3
10	DC12	3-Drawer Unit	1
11	9	4-Drawer Unit w/ Lock	1
12	TA1WAD	4-Hook Bar w/ Adapter	1
13	BRK14EPS	End Panel Mounting Bracket	2
14	WKC1FDTS	Steel Partition Mounting Kit	1

GENERAL SERVICE STARTER PACKAGE

4317TL130 Transit 130"WB Low Roof
4317TL148 Transit 148"WB Low Roof

ITEM	MODEL	DESCRIPTION	QTY
1	AD44FP	Adjustable 3-Shelf Unit	3
2	RK130FTS or RK148FTS	Mounting Rail Kit	1
3	DV14C8	14" Shelf Dividers	1
4	919	3-Drawer Unit w/ Lock	1
5	S1M2HC2FSV	Steel Partition Panel Kit w/ Visibility & Door Kit	1
6	UH50	Utility Hook	2
7	DK4208	Door Kit w/ Open Back	2
8	TA1WAD	4-Hook Bar w/ Adapter	1
9	19	2-Drawer Unit w/ Lock	1
10	DC6	3-Drawer Unit	1
11	BRK14EPS	End Panel Mounting Bracket	1
12	WKC1FDTS	Steel Partition Mounting Kit	1

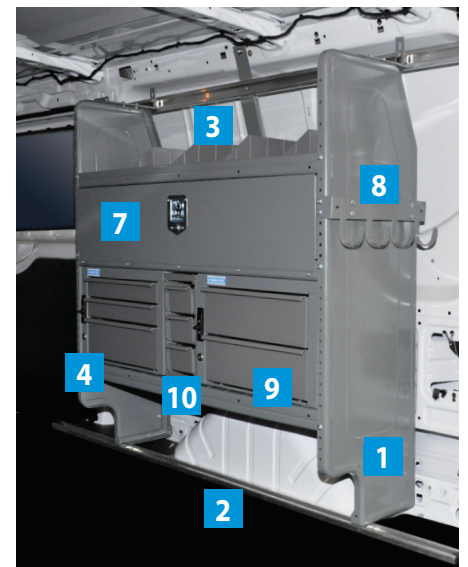
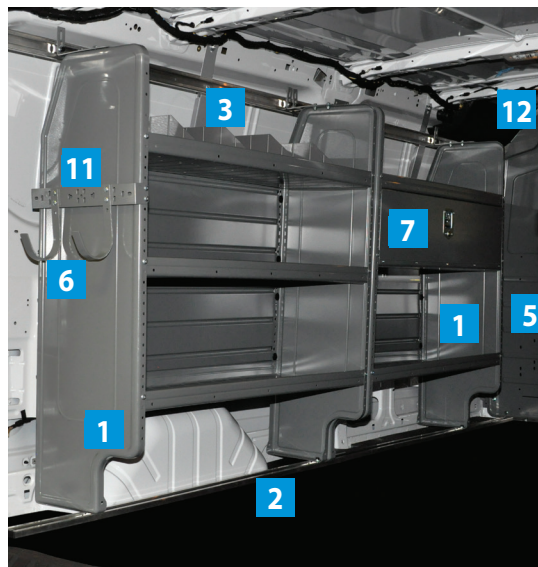

PLUMBING & HVAC STARTER PACKAGE

4318TL130 Transit 130"WB Low Roof
4318TL148 Transit 148"WB Low Roof

ITEM	MODEL	DESCRIPTION	QTY
1	AD44FP	Adjustable 3-Shelf Unit	3
2	RK130FTS or RK148FTS	Mounting Rail Kit	1
3	DV14C8	14" Shelf Dividers	1
4	919	3-Drawer Unit w/ Lock	1
5	S1M2HC2FSV	Partition with door	1
6	TR230150	Welded Tank Rack	1
7	19	2-Drawer Unit w/ Lock	2
8	DC6	3-Drawer Unit	3
9	DC12	3-Drawer Unit	1
10	DK4208	Door Kit w/ Open Back	2
11	TA1WAD	4-Hook Bar w/ Adapter	1
12	RKAWTR	Welded Tank Rack Rail Adapter	1
13	WKC1FDTS	Steel Partition Mounting Kit	1

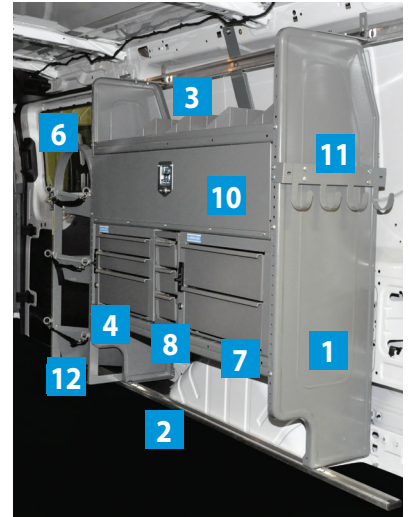
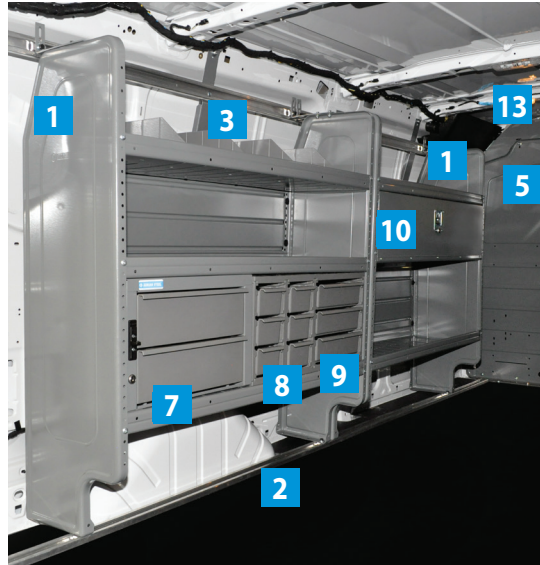

LOCKSMITH STARTER PACKAGE

5274TL Transit 130"/148"WB Low Roof

ITEM	MODEL	DESCRIPTION	QTY
1	17A	6-Shelf Catalog File	1
2	MD506	Shelf and Drawer Module	1
3	MD608	Workbench Module	1
4	S1M2HC2FSV	Partition with door	1
5	TA1	4-Hook Bar	1
6	WKC1FDTS	Steel Partition Mounting Kit	1

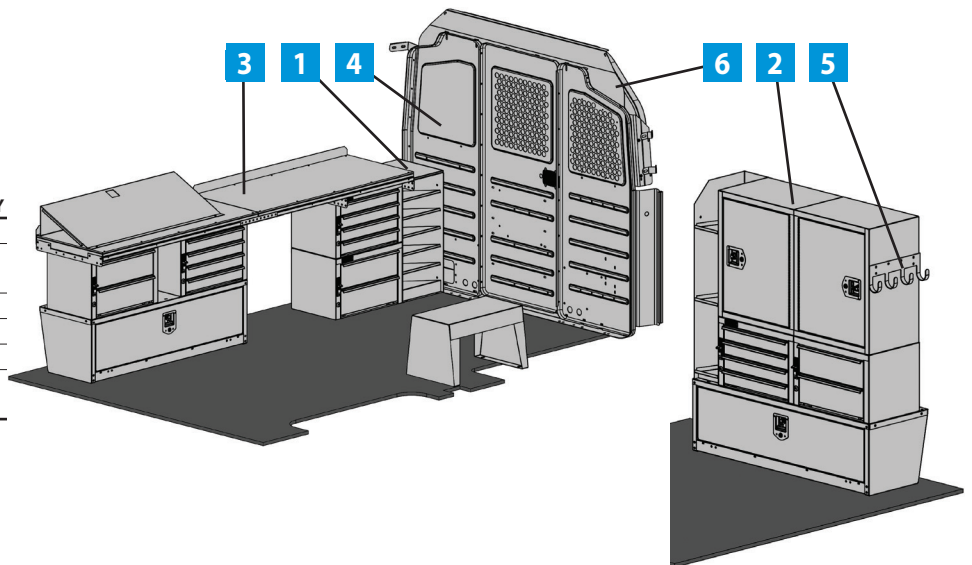

GENERAL SERVICE STARTER PACKAGE

4317TM130 Transit 130"WB Med Roof
4317TM148 Transit 148"WB Med Roof

4317TH148 Transit 148"WB High Roof
4317TH148X Transit 148"EXT WB High Roof

ITEM	MODEL	DESCRIPTION	QTY
1	HAD4459	Hybrid 4-Shelf Unit	3
2	RAIL KIT	*see list below	1
3	S1M2HC2PM	Steel Partition Panel Kit w/ Visibility & Door Kit	1
4	WKC1FDTM	Steel Partition Mounting Kit	1
or	WKC1FDTH	Steel Partition Mounting Kit	1
5	BRK14EPS	End Panel Mounting Bracket	1
6	BR36212	Bin Set for Adjustable Shelving	1
7	DC6	3-Drawer Unit	1
8	DV14C8	14" Shelf Dividers	1
9	TA1WAD	4-Hook Bar w/ Adapter	1
10	UH50	Utility Hook	2
11	919	3-Drawer Unit w/ Lock	1
12	9	4-Drawer Unit w/ Lock	1

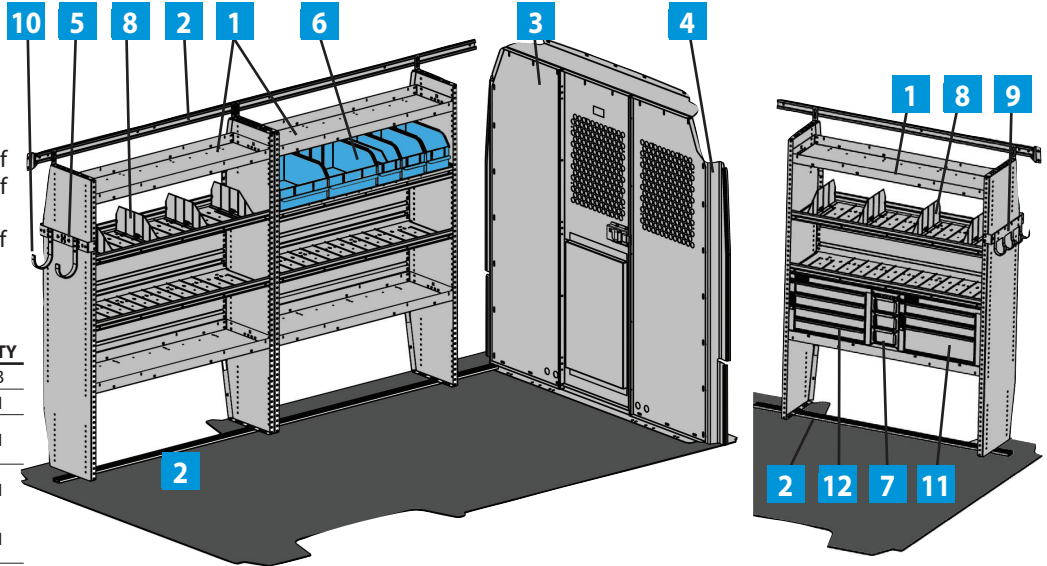

ELECTRICAL & GAS STARTER PACKAGE

4319TM130 Transit 130"WB Med Roof
4319TM148 Transit 148"WB Med Roof

4319TH148 Transit 148"WB High Roof
4319TH148X Transit 148"EXT WB High Roof

ITEM	MODEL	DESCRIPTION	QTY
1	HAD4459	Hybrid 4-Shelf Unit	3
2	RAIL KIT	*see list below	1
3	S1M2HC2PM	Steel Partition Panel Kit w/ Visibility & Door Kit	1
4	WKC1FDTM	Steel Partition Mounting Kit	1
or	WKC1FDTH	Steel Partition Mounting Kit	1
5	BRK14EPS	End Panel Mounting Bracket	4
6	BR76012	Bin Set for Adjustable Shelving	1
7	BR36212	Bin Set for Adjustable Shelving	1
8	DC6	3-Drawer Unit	1
9	DV14C8	14" Shelf Dividers	1
10	TA1WAD	4-Hook Bar w/ Adapter	1
11	CB5	5-Slot Literature Rack	1
12	DK4210	Door Kit w/ Open Back	2
13	WRH5	5-Bar Spool Holder	1
14	9	4-Drawer Unit w/ Lock	2

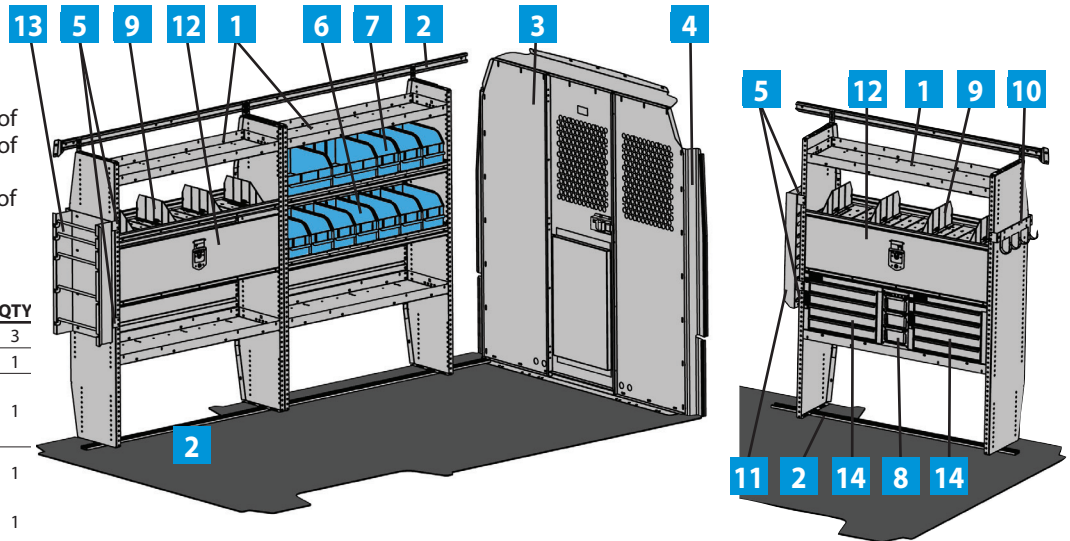

***RAIL KITS**

MODEL	DESCRIPTION
RK130FTM	Mounting Rail Kit
RK148FTM	Mounting Rail Kit
RK148FTH	Mounting Rail Kit

PLUMBING & HVAC STARTER PACKAGE

4318TM130 Transit 130"WB Med Roof

4318TM148 Transit 148"WB Med Roof

4318TH148 Transit 148"WB High Roof

4318TH148X Transit 148"EXT WB High Roof

ITEM	MODEL	DESCRIPTION	QTY
1	HAD4459	Hybrid 4-Shelf Unit	3
2	RAIL KIT	*see list on page 28	1
3	S1M2HC2PM	Steel Partition Panel Kit w/ Visibility & Door Kit	1
4	WKC1FDTM	Steel Partition Mounting Kit	1
or	WKC1FDTH	Steel Partition Mounting Kit	1
5	BRK14EPS	End Panel Mounting Bracket	2
6	BR36212	Bin Set for Adjustable Shelving	1
7	DC6	3-Drawer Unit	1
8	DV14C8	14" Shelf Dividers	1
9	TA1WAD	4-Hook Bar w/ Adapter	1
10	TR230150	Welded Tank Rack	1
11	CB5	5-Slot Literature Rack	1
12	DK4210	Door Kit w/ Open Back	1
13	RKAWTR	Welded Tank Rack Rail Adapter	1
14	19	2-Drawer Unit w/ Lock	2

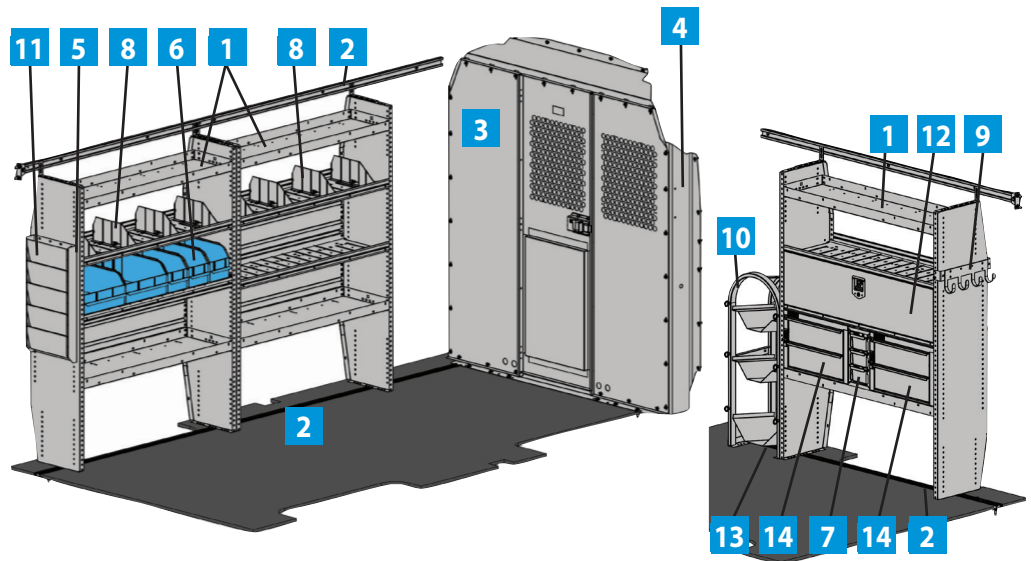

LOCKSMITH STARTER PACKAGE

5274TM Transit 130"/148" WB Med Roof

5274TH Transit 148"/148" EXT WB High Roof

ITEM	MODEL	DESCRIPTION	QTY
1	17A	6-Shelf Catalog File	1
2	MD506PM	Drawer Cabinet Module	1
3	MD608PM	Workbench Module	1
4	S1M2HC2PM	Steel Partition Panel Kit w/ Visibility & Door Kit	1
5	TA1	4-Hook Bar	1
6	WKC1FDTM	Steel Partition Mounting Kit	1
or	WKC1FDTH	Steel Partition Mounting Kit	1

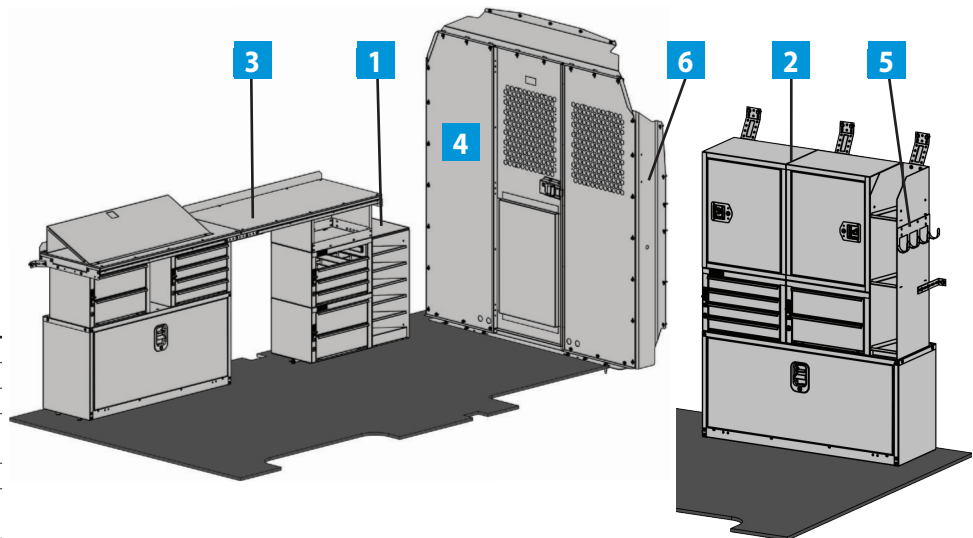



**5219
GENERAL SERVICE STARTER
PACKAGE**

2014-on Transit Connect LWB

ITEM	MODEL	DESCRIPTION	QTY
1	AD1232TC14	Adjustable 3-Shelf Unit	4
2	DC12	3-Drawer Unit	2
3	DC6	3-Drawer Unit	2
4	DK32TC	Door Kit	1
5	P2TCS14	Steel Partition w/ Visibility	1
6	RKDTC14	Mounting Rail Kit	2
7	TA1	4-Hook Bar	1
8	28	Parts Bin	6
9	919	3-Drawer Unit w/ Lock	1

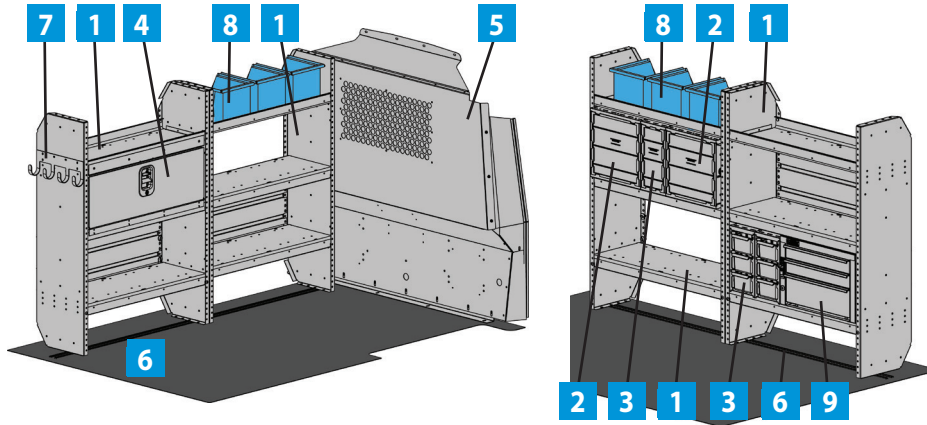

**5225
GENERAL SERVICE STARTER
PACKAGE**

2014-on Transit Connect SWB

ITEM	MODEL	DESCRIPTION	QTY
1	AD1226TC14	Adjustable 3-Shelf Unit	2
2	DC6	3-Drawer Unit	1
3	DK26TC	Door Kit	1
4	P2TCS14	Steel Partition w/ Visibility	1
5	RKTC14	Mounting Rail Kit	2
6	TA1	4-Hook Bar	1
7	919	3-Drawer Unit w/ Lock	1

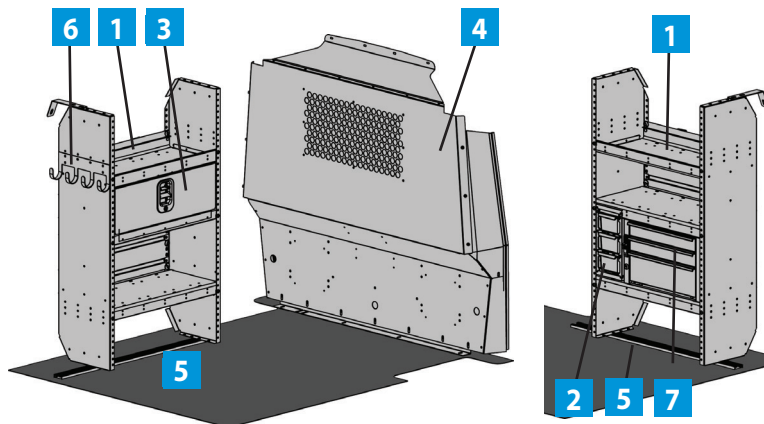

All illustrations, photos and specifications in this publication are based on the latest product information available at the time of content approval. The right is reserved to make changes at any time, without notice, in materials, specifications and models, and also to discontinue models.

**5217
HVAC Starter Package**
2014-on Transit Connect LWB

ITEM	MODEL	DESCRIPTION	QTY
1	AD1226TC14	Adjustable 3-Shelf Unit	2
2	AD1232TC14	Adjustable 3-Shelf Unit	1
3	DC12	3-Drawer Unit	1
4	DC6	3-Drawer Unit	4
5	P2TCS14	Steel Partition w/ Visibility	1
6	RKAWTR	Welded Tank Rack Rail Adapter	1
7	RKDTC14	Mounting Rail Kit	1
8	RKTC14	Mounting Rail Kit	1
9	TA1	4-Hook Bar	2
10	TR130250	Welded Tank Rack	1
11	28	Parts Bin	3
12	46361-G	Mounting Bracket	3
13	919	3-Drawer Unit w/ Lock	1

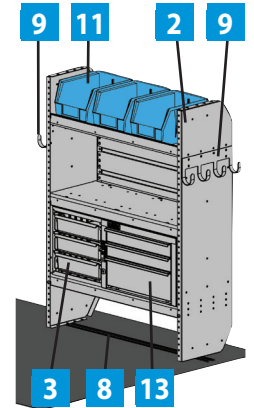
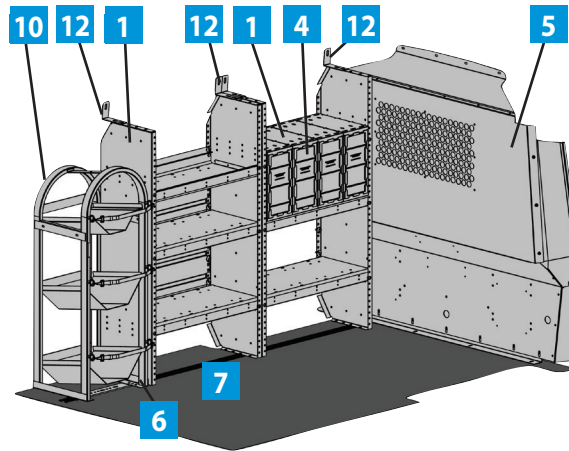

**5220
ELECTRICAL STARTER PACKAGE**
2014-on Transit Connect LWB

ITEM	MODEL	DESCRIPTION	QTY
1	AD1232TC14	Adjustable 3-Shelf Unit	3
2	DK32TC	Door Kit	1
3	P2TCS14	Steel Partition w/ Visibility	1
4	RKDTC14	Mounting Rail Kit	1
5	RKTC14	Mounting Rail Kit	1
6	TA1	4-Hook Bar	2
7	DC12	3-Drawer Unit	1
8	28	Parts Bin	6
9	919	3-Drawer Unit w/ Lock	1

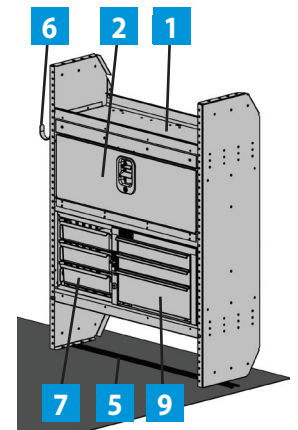
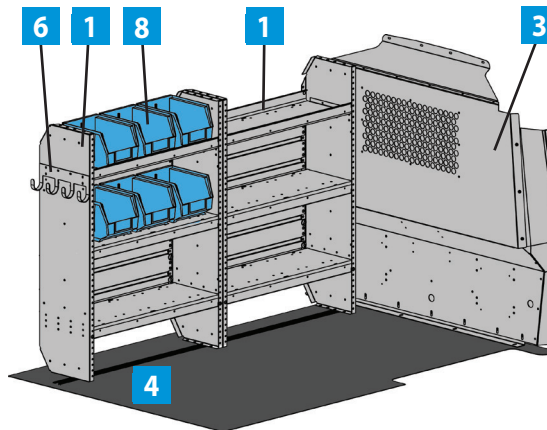

**5222
PLUMBING STARTER PACKAGE**
2014-on Transit Connect LWB

ITEM	MODEL	DESCRIPTION	QTY
1	AD1232TC14	Adjustable 3-Shelf Unit	3
2	DC6	3-Drawer Unit	8
3	DK32TC	Door Kit	1
4	P2TCS14	Steel Partition w/ Visibility	1
5	RKDTC14	Mounting Rail Kit	1
6	RKTC14	Mounting Rail Kit	1
7	UH50	Utility Hook	2
8	28	Parts Bin	3
9	919	3-Drawer Unit w/ Lock	1
10	DC12	3-Drawer Unit	2

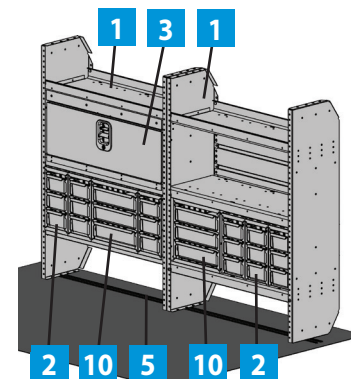
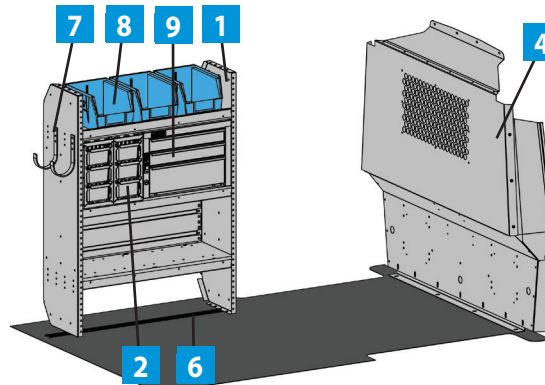

All illustrations, photos and specifications in this publication are based on the latest product information available at the time of content approval. The right is reserved to make changes at any time, without notice, in materials, specifications and models, and also to discontinue models.

MODEL	PAGE	DESCRIPTION	MODEL	PAGE	DESCRIPTION	MODEL	PAGE	DESCRIPTION
1	14	Adjustable Single Shelf CaBINet w/Lock	4319TM148	34	Electrical & Gas Starter Package	70-2NGLR	27	6" End Cap for PVC Conduit
12	14	Adjustable Single Shelf Cabinet w/Lock	4432	12	Welded 3-Shelf Unit	80-1	25	Conduit Carrier
12A	14	Cabinet End Panel	4442	12	Welded 3-Shelf Unit	80-1NGLR	27	10"6" Conduit Kit
14	21	Step Stool	4450	12	Welded 3-Shelf Unit	80-2	25	Conduit Kit
17A	13, 17	6-Shelf Catalog File	45047	20	Burco glass rack	80-2NGLR	27	12"6" Conduit Kit
18	13	Welded 3-Shelf Unit w/ Dividers	46361-G	37	Mounting Bracket	8	13, 15	3-Drawer Unit
19	15	2-Drawer Unit w/ Lock	4B	21	Parts Tray	9	15	4-Drawer Unit w/ Lock
1A	14	Cabinet Shelf	5217	37	HVAC Starter Package	919	15	3-Drawer Unit w/ Lock
1BARRFT-W	25	Center Cross Bow Kit	5219	37	General Service Starter Package	ACT3	21	3-Place Aerosol Can Holder
1BTCGL	14	Center Cross Bow Kit	5220	37	Electrical Package	ACT4	21	4-Place Aerosol Can Holder
2	15	4-Drawer Unit	5222	37	Plumbing Starter Package	AD1226TC14	10	Adjustable 3-Shelf Unit
27	15	Drawer Divider Assembly	5225	37	General Service Starter Package	AD1232TC14	10	Adjustable 3-Shelf Unit
28	12	Parts Bin	5274TH	35	Locksmith Starter Package	AD1426TC14	10	Adjustable 3-Shelf Unit
2B4W	28	2-Bar w/ 4" Uprights	5274TL	35	Locksmith Starter Package	AD1432TC14	10	Adjustable 3-Shelf Unit
2B6W	28	2-Bar w/ 6" Uprights	5274TM	35	Locksmith Starter Package	AD32FP	10, 11	Adjustable 3-Shelf Unit
2B9W	28	2-Bar w/ 9" Uprights	60-132	19	Passenger Side Rear Door Security Screen	AD44FP	10, 11	Adjustable 3-Shelf Unit
35325-G	10	32" ADseries Shelf	60-133	19	Driver Side Rear Door Security Screen	AD50FP	10, 11	Adjustable 3-Shelf Unit
35327-G	10	44" ADseries Shelf	60-134	19	Passenger Side Rear Door Security Screen	BH4	17	4-Slot Literature Rack
35328-G	10	50" ADseries Shelf	60-135	19	Driver Side Rear Door Security Screen	BRK14EPS	10	End Panel Mounting Bracket
3B4W	28	3-Bar w/ 4" Uprights	60-136	19	Passenger Side Sliding Door Security Screen	CB5	17	5-Slot Literature Rack
3B6W	28	3-Bar w/ 6" Uprights	60-138	19	Passenger Side Sliding Door Security Screen	CB7	17	7-Slot Literature Rack
3B9R9W	28	3-Bar w/ 9" & 9" Ratchet Uprights	60-140	19	Passenger Side Door Security Screen	CCD6	17	Center Console
3B6RRFTW	28	3-Bar w/ 6" Uprights & Rear Roller, Transit	60-141	19	Passenger Side Door Security Screen	CCD9	17	Center Console
40	14	Wheelhouse Bin	60-TC14RB	19	Rear Doors Security Screen Kit	CCDHF6	17	Center Console Hanging File
43	13, 17	3-Shelf Literature Rack	60-TCL14S	19	Sliding Doors Security Screen Kit	CCDLTH	17	Center Console Laptop Holder
4317TH148	34	General Service Starter Package	60-TCS14S	19	Sliding Doors Security Screen Kit	CH-1514DBL	16	2-Case Holder w/ Cases
4317TH148X	34	General Service Starter Package	60-TRLHDRD	19	Passenger Side Hinged & Rear Doors Security Screen Kit	CH-EP	16	3-Case Holder w/ Cases
4317TL130	34	General Service Starter Package	60-TRLRDR	19	Rear Doors Security Screen Kit	CH1514SGL	16	Single Case Holder w/ Case
4317TL148	34	General Service Starter Package	60-TRLSDR	19	Passenger Side Sliding & Rear Doors Security Screen Kit	CHPPC4S	16	4-Case Holder w/ Cases
4317TM130	34	General Service Starter Package	60-TRMHRDR	19	Rear Doors Security Screen Kit	CHPPCSSM	16	5-Case Holder w/ Cases
4317TM148	34	Gen Svc. Pkg, 148" med roof	60-TRMHSDR	19	Passenger Side Sliding & Rear Doors Security Screen Kit	CL1446R	14	Adjustable 3-Shelf Cabinet w/ Lock
4318TH148	35	Plumbing & HVAC Starter Package	61-GLFTL2	24	Single Grip Lock Ladder Rack	DC12	15	3-Drawer Unit
4318TH148X	35	Plumbing & HVAC Starter Package	61-TCL19	25	Single Grip Lock Ladder Rack	DC6	15	3-Drawer Unit
4318TL130	33	Plumbing & HVAC Starter Package	61-TCS19	25	Single Grip Lock Ladder Rack	DDL61FTL	22	Passenger Side Drop Down Ladder Rack
4318TL148	33	Plumbing & HVAC Starter Package	63-GLFTL2	24	Double Grip Lock Ladder Rack	DDL61FTM	23	Single Drop Down Ladder Rack
4318TM130	35	Plumbing & HVAC Starter Package	63-TCL19	25	Double Grip Lock Ladder Rack	DDL63FTL	22	Double Drop Down Ladder Rack
4318TM148	35	Plumbing & HVAC Starter Package	63-TCS19	25	Double Grip Lock Ladder Rack	DDL63FTM	23	Double Drop Down Ladder Rack
4319TH148	34	Electrical & Gas Starter Package	70-1LR	22, 24	Conduit Kit w/ Round End Caps	DDL63FTM	23	Double Drop Down Ladder Rack
4319TH148X	34	Electrical & Gas Starter Package	70-1NGLR	27	4" End Cap for PVC Conduit	DDL63FTM	23	Double Drop Down Ladder Rack
4319TL130	28	Electrical & Gas Starter Package	70-2LR	22, 24	Conduit Kit w/ Round End Caps	DDL63FTM	23	Double Drop Down Ladder Rack
4319TL148	34	Electrical & Gas Starter Package				DDL63FTM	23	Double Drop Down Ladder Rack
4319TM130	34	Electrical & Gas Starter Package				DDL63FTM	23	Double Drop Down Ladder Rack

MODEL	PAGE	DESCRIPTION
DV44U1	12	Top Shelf Divider
DV44U	12	Top Shelf Divider Kit
DV44U4	12	Top Shelf Divider Kit
DV9	18	Floor Drawer Divider
DVJ19	18	Floor Drawer Divider
DVJ9	18	Floor Drawer Divider
FSFK2048	31	Folding Shlef Kit, 20 x 48
FSFK2060	31	Folding Shlef Kit, 20 x 60
FSFMKFT	31	Shelf Mounting Kit
FSFMKFTA	31	Shelf Mounting Kit Add-On
FSFPKM	31	Upright Mounting Kit
FSFPKMHA	31	Upright Mounting Kit Add-On
FTMBK4W	28	Mounting Brackets, 4-Pack
FTMBK2W	28	Mounting Brackets, 2-Pack
GHFT	31	Grab Handle
HAD4459	11	Hybrid 4-Shelf Unit
HAD5059	11	50" HAD Shelving
HD4459	11	4-Shelf Unit
HD5059	11	4-Shelf Unit
ILR	25	Ladder Holder
JD42FP	11	3-Shelf Unit
JD48FP	11	2-Shelf Unit
JD52FP	11	3-Shelf Unit
JD60FP	11	3-Shelf Unit
KMB36	13	Key Machine Base
LK8FT148	25	Ceiling Ladder Holder
LK8FT	25	Ceiling Ladder Holder
MD506	13	Shelf and Drawer Module
MD507	13	Shelf and Drawer Module
MD508	13	Workbench Module
MD509	13	Workbench Module
MD608	13	Module, Workbench
P2TCFW14	9	Wire Partition
P2TCS14	9	Steel Partition w/ Visibility
PA10	8	File Holder
PA5-1	8	Partition Climate Control Kit
PA5-2	8	Partition Climate Control Kit
PA5-SPR	8	Partition Climate Control Kit
PA7	8	Reflector Kit w/ Bracket
PA8	8	Fire Extinguisher
PA9	8	First Aid Tray
PARFTH-NW	7	Composite Partition
PARFTH	7	Composite Partition w/ Visibility
PARFTL-NW	6	Composite Partition
PARFTL	6	Composite Partition w/ Visibility
PARFTM-NW	7	Composite Partition
PARFTM	7	Composite Partition w/ Visibility
PARTC-NW	8	Composite Partition
PARTC	8	Composite Partition w/ Visibility
PDK1	8	Steel Partition Door Kit
PPCL	16	Large Portable Parts Case
PPCS	16	Small Portable Parts Case
PROFILE RACK	26,27	HD Utility Rack
RK130FTM	10	Mounting Rail Kit
RK130FTS	10	Mounting Rail Kit
RK148FTHE	10	Mounting Rail Kit
RK148FTM	10	Mounting Rail Kit
RK148FTS	10	Mounting Rail Kit
RKA1	10	Rail Kit Adapter
RKA3	10	Rail Kit Adapter
RKA4	10	Rail Kit Adapter

MODEL	PAGE	DESCRIPTION
RKA919	10	Drawer Riser Kit
RKAWTR	10	Welded Tank Rack Rail Adapter
RKDTC14	10	Mounting Rail Kit
RKTC14	10	Mounting Rail Kit
RRBFTRP-W	25	Rear Roller Bar
S1M1C1FSV	6, 7	Steel Partition Panel Kit
S1M1C1PM	6, 7	Steel Partition Panel Kit
S1M2C2FSV	6, 7	Steel Partition Panel Kit w/ Visibility
S1M2C2PM	6, 7	Steel Partition Panel Kit w/ Visibility
S1M2HC2FSV	6, 7	Partition, low roof
S1M2HC2PM	6, 7	Steel Partition Panel Kit w/ Visibility & Door Kit
SA-10	18	Single Compartment Floor Drawer
SA-20	18	Single Compartment Floor Drawer
SA-40	18	Triple Compartment Floor Drawer
SAJ-10	18	Single Compartment Floor Drawer
SAJ-20	18	Single Compartment Floor Drawer
SAJ-30	18	Double Compartment Floor Drawer
SAJ-40	18	Triple Compartment Floor Drawer
SBIN060614	20	Snap In Bin
SBIN120614	20	Snap In Bin
SBINDIV	20	Snap In Bin Divider
SPARFTH	31	Sliding Partition, Transit High Roof
SPARFTM	31	Sliding Partition, Transit Mid Roof
STEPFTRD	31	Rear Door Step
STEPFTSD	31	Side Door Step
STP12B	21	Touch-Up Paint
STP12G	21	Touch-Up Paint
STP12W	21	Touch-Up Paint
TA1	8	4-Hook Bar
TA19	14	Compressed Gas Tank Cabinet
TA1WAD	32	4-Hook Bar w/ Adapter
TA2	21	Hard Hat Holder
TCMBK4W	28	Mounting Brackets, 4-Pack
TCMBK2W	28	Mounting Brackets, 2-Pack
TDC6	17	Tech Desk Console
TDC9	17	Tech Desk Console
TH30	8	Tank Holder
TH50	8	Tank Holder
TR330	20	Tank Rack, 3 (30lb)
TR230150	20	Tank Rack, 2 (30lb), 1 (50lb)
TR350	20	Tank Rack, 3 (50lb)
TR430	20	Tank Rack, 4 (30lb)
TRSHELF30	20	4" Shelf for 30 lb. Racks
TRSHELF50	20	4" Shelf for 50 lb. Racks
UH10	21	Utility Hook
UH25	21	Utility Hook
UH50	21	Utility Hook
VMA36	21	Vise Mount Assm.
WKC1FDTH	7	Steel Partition Mounting Kit
WKC1FDTM	7	Steel Partition Mounting Kit
WKC1FDTS	7	Steel Partition Mounting Kit
WRH5	19	5-Bar Spool Holder



ADRIAN STEEL®

Cargo Management Solutions for Commercial Vehicles

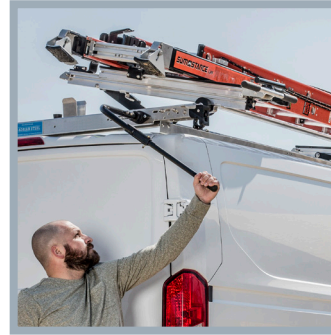

QUALITY

- Our products are durable and reliable. Warranty claims are less than 1% of sales.
- Our warranty covers our products for three years or 36,000 miles.

INNOVATIVE PRODUCTS WITH FEATURES THAT MATTER

- Drawers that stay closed while in transit.
- ADseries truly adjustable shelving platform.
- Drop Down and Grip Lock ladder racks that load and unload the safe and right way.
- Interior ladder storage.
- Plug and Play accessories.
- Anti-slam drawer latches, and much more!

COMMITMENT

At Adrian Steel, we are committed to you beyond the upfit!

- A dedicated Customer Care Team at corporate headquarters.
- A network of highly qualified distributors to support you locally.
- Our commitment to provide the best cargo management solutions in North America.



EXPERIENCE

- **Over One Million vans upfitted**, and counting! It's a fact that an organized vehicle increases work flow efficiencies and reduces inventory damages.
- Recognized as a National Truck Equipment Association MVP.

SERVICE

- Adrian Steel Products can be purchased throughout North America at authorized Adrian Steel distributors.
- Adrian Steel Customer Service Representatives are available M-F, 8am - 5pm EST at **1-800-677-2726**.
- E-mail us at info@adriansteel.com with questions, comments and feedback.
- Visit AdrianSteel.com for the most up-to-date product information, distributor locator, product catalogs, videos and more.

adriansteel.com

800-677-2726

906 James St.
Adrian, MI 49221