



TS/ISO Registered

ADRIAN STEEL®

Cargo Management Solutions for Commercial Vehicles

CARGO VAN EQUIPMENT



WORK READY VANS

CARGO MANAGEMENT SOLUTIONS

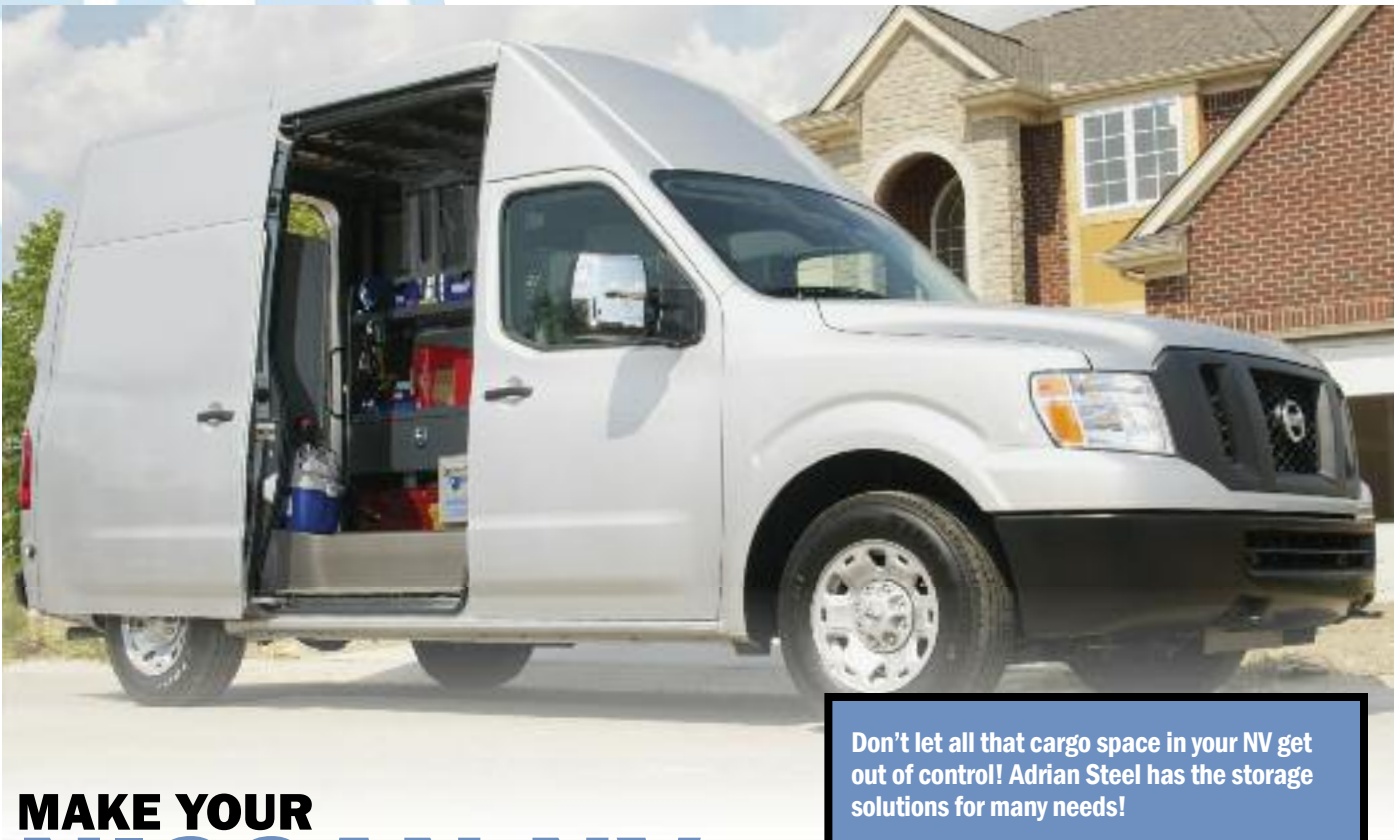

MAKE YOUR **NISSAN NV** WORK READY!

Don't let all that cargo space in your NV get out of control! Adrian Steel has the storage solutions for many needs!

Choose a Work Ready Upfit to match your trade, or create your own interior with a variety of shelving, cabinets and storage units.

Complete the upfit with a vehicle graphic from Commercial Curb Appeal that will advertise you at every jobsite.

THANK YOU FOR CHOOSING ADRIAN STEEL.

This catalog will prove to be a valuable tool to help you decide the products that will fill your cargo management needs. Need a professional opinion? Contact your local Adrian Steel distributor for the best advice on turning your Nissan NV into a true asset to your business.

FROM OUR BEGINNING IN 1953 as a small structural steel warehouse with four employees, Adrian Steel Company has grown to become a leader in the van and truck equipment industry. Located in Adrian, Michigan, our manufacturing facility now encompasses over 166,000 square feet. Adrian Steel is committed to providing quality products highlighted by constant innovation.

Adrian Steel's attention to detail and customers is thorough, it began through the corporate values instilled by founder Bob Westfall, University of Michigan All-American and Detroit Lion All-Pro football standout. Those values instilled a team effort to provide customers with value-added products and services that have become the standard of our industry.



PLAN YOUR WORK READY VAN

TIME IS MONEY! GET ON THE ROAD WITH EVERYTHING YOU NEED TO GET BACK TO BUSINESS.

Adrian Steel has all the storage products you will need, and the distributor network to professionally install your interior and graphics to get you serving your customers faster. Below is a guide to help you set up your work van with the equipment you need to get the job done. Build your own interior with our modular products, or start with a Work Ready Van Package (pages 18-22) and modify it to your specific needs. Then, utilizing the Commercial Curb Appeal design tool, create a custom graphic to complete your work van upfit.

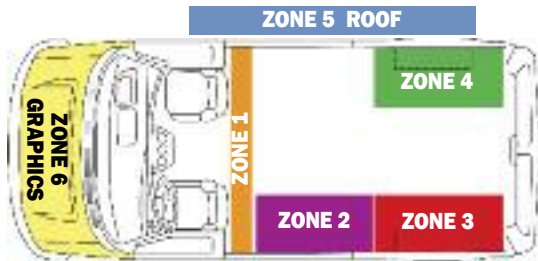

ZONE 1 PARTITION

- Choose partition style: solid or perforated. See page 8.
- Choose the standard or 3" setback Max Comfort wing kit.
- Add accessories.
- **I need:**

ZONES 2, 3, 4 CURBSIDE & STREETSIDE

- Use layout diagram to determine the amount of space available.
- Choose from a variety of shelving units and modules that will best organize the tools and equipment you need to carry.
- Or, choose a Work Ready Upfit, complete with a trade specific, pre-designed interior and custom graphics package.
- **I need:**

ADDITIONAL STORAGE

- Determine the space needed for specialty equipment.
- Add accessories to shelving and partition
- Hooks, drawers, files, screens, and more.
- See available accessories on pages 12-13.
- **I need:**

ZONE 5 ROOF

- What do you need to carry?
- Choose from the LoadsRite drop-down ladder rack or the versatile Utility Rack.
- Add rack accessories.
- Or add a Ladder Keeper interior ladder rack.
- **I need:**

ZONE 6 VEHICLE GRAPHICS

- Stand out in the crowd!
- Vehicle graphics are the most cost effective form of advertising!
- Go to www.commercialcurbappeal.com and start designing!



NISSAN NV WITH STANDARD PARTITION SETBACK 2011-ON

* Subtract 3" from dimension when a Max Comfort partition wing kit is installed.

Note: Dimensions for reference only. Measure your van or contact your distributor for your exact needs.

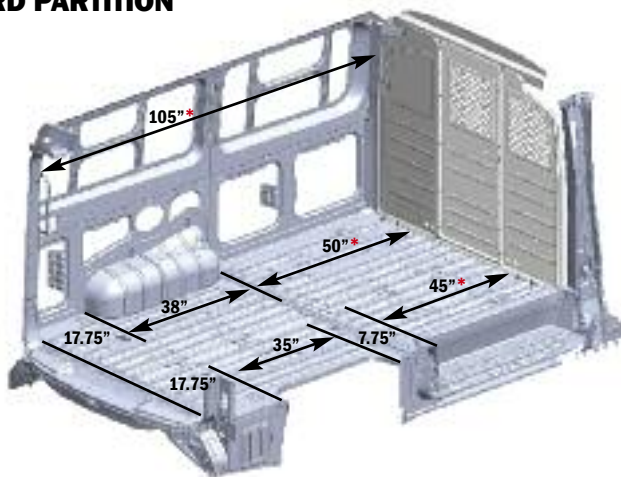

Need some help? Contact your local distributor! They can provide a wealth of information about utilizing the cargo space in your work van. Find your local distributor online at adriansteel.com.

INDEX

| | |
|-------|--------------------------|
| 3 | Plan Your Work Ready Van |
| 4-5 | Commercial Curb Appeal |
| 6-7 | ADseries Shelving |
| 8-9 | Partitions & Accessories |
| 10-11 | Storage Modules |

| | |
|-------|--------------------------|
| 12-13 | Files & Van Accessories |
| 14-16 | Roof Racks & Accessories |
| 17 | Ladder Keeper |
| 18-22 | Work Ready Upfits |
| 23 | Index |

All illustrations, photos and specifications in this publication are based on the latest product information available at the time of content approval.

The right is reserved to make changes at any time, without notice, in materials, specifications and models, and also to discontinue models.



commercial **Curb Appeal**

STAND OUT **IN THE** CROWD

MOBILIZE YOUR BRAND WITH ADRIAN STEEL'S VEHICLE GRAPHICS PROGRAM.

WHY CHOOSE COMMERCIAL CURB APPEAL?

Adrian Steel and Signature Graphics, Inc. have partnered since 1996 providing graphic programs to the largest fleets in North America. As the leaders in our respective industries we decided to provide premium vehicle graphics to the small businesses and commercial customers that were once reserved only for Fortune 500 Organizations. Your brand and Signature's custom design tools online allow any size organization to compete with the largest brands in North America for visibility and quality of product on your commercial vehicle. All of this and the convenience of your local Adrian Steel Distributor, a trusted source of Commercial Van and Truck products for over 50 years.



WHY VEHICLE GRAPHICS?

Take charge of your brand by advertising your business on your work vehicle. Vehicle graphics are the most cost effective form of advertising available! Check out these stats provided by The Trucking Association & Outdoor Advertising Association of America:

- The average Delivery / Service vehicle makes approximately 16 million visual impressions annually!
- Reflective Graphics boost visual impressions by up to 40% by extending visibility during odd operating hours.
- 91% notice words and images on commercial vehicles.
- 29% would base a buying decision based on the impression of that company's commercial graphics.
- 97% remember ads placed on commercial vehicles vs. 19% for billboards.
- 98% feel vehicle graphics create a positive image of the advertiser.

Based on CPM (Cost per impression,) Fleet Graphics are most cost effective form of advertising when bringing your brand to the marketplace.

| Advertising Type | Cost Per Impression |
|------------------------------------|---------------------|
| FLEET GRAPHICS | \$0.90 |
| BILLBOARD (city/national) | \$3.00 |
| RADIO (30 sec. prime time) | \$4.95 |
| MAGAZINE (1/4 page) | \$8.00 |
| TV SPOT (30 sec prime time) | \$16.25 |
| NEWSPAPER AD (1/2 page B&W) | \$19.20 |

TRANSFORM YOUR BUSINESS IN FOUR EASY STEPS:

1. ADVERTISE YOUR BUSINESS WITH A CUSTOM DESIGNED VEHICLE GRAPHIC.

Your work vehicle is one of your most visible assets of your company. Attract customers by creating an eye-catching, fresh and hard to pass by design with the simple and intuitive design tool from Commercial Curb Appeal. Whether you are on the job or on vacation, your vehicle will be advertising your services and making your brand more visible, 24/7. Not the creative type? No problem! The online design tool is easy to use with professionally designed templates and an image gallery ready to use. You can also upload your own images and logos. Your local Adrian Steel distributor is trained and available to help walk you through the design process.

2. TOP-QUALITY SUPPORT

Once you have created your design, use the estimator program to figure your final cost. Save and print off your design, then take it to your local Adrian Steel distributor. Your distributor will order the graphics for you and professionally install them when they arrive. Find your local distributor at: www.adriansteel.com/distributors

3. HIGH QUALITY FILMS AND DIGITAL PRINTING

Your design will be printed on premium cast films, products once only available to the largest fleets. Printing is done on a state-of-the-art grand format digital printer and will be finished with a UV clear coat or overlamine to resist fading for a longer life. The graphics you receive from the Commercial Curb Appeal program are commercial grade and will be covered under Adrian Steel's 3 year, 36,000 mile warranty.

4. PROFESSIONALLY INSTALLED FOR YOU

You can expect your graphics to receive the same professional installation as you would any Adrian Steel product. Save time and money by having your upfit and graphics installation scheduled together. From creation to installation, Adrian Steel has you covered.



Pick a template



Upload images



Professional installation

GET THE ATTENTION YOU DESERVE

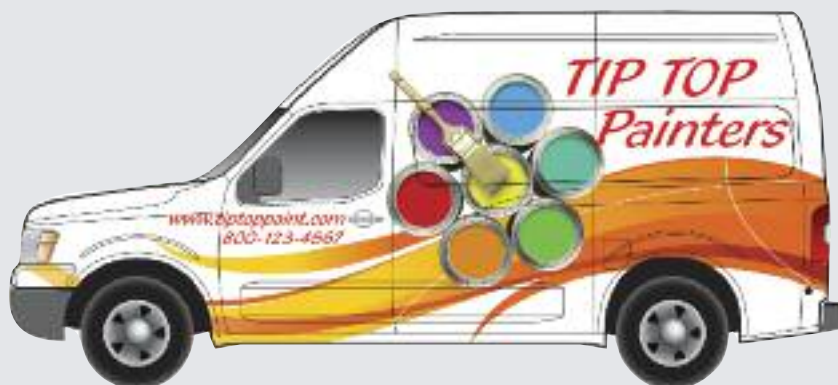

**Start Creating Today at:
www.commercialcurbappeal.com**



800.677.2726

ADSERIES ADJUSTABLE SHELVING

EXCLUSIVELY FROM ADRIAN STEEL: A SHELVING PLATFORM THAT ALLOWS YOU TO PUT SHELVES WHERE YOU WANT THEM, NOT WHERE WE THINK YOU NEED THEM!

ADseries is the next generation of cargo management solutions, engineered to optimize your work van storage and accessibility. Featuring truly ADjustable shelves, an ADaptable rail system, heavy-duty shelves and an ADvanced stamped steel end panel designed to accommodate the diverse range of cargo you need to get the job done. ADseries is ADrian made and backed by our industry-leading 3 year/36,000 mile warranty.



ADVANCED DESIGN

Stamped steel end panels and shelves, ADseries components are strong, durable and ready to work hard. 6" knock out provides a 48" floor space to accommodate 4'x 8' sheet goods (up to 22 sheets of 1/4" drywall or a combination of thicknesses).

Nissan NV end panels provide 38.75" between the panels from the top to bottom maximizing aisle space.



**SEE THE
ADSERIES IN
ACTION!**

**VISIT
ADRIANSTEEL.COM!**

ADSERIES ADJUSTABLE SHELVING

ADJUSTABLE SHELVES

Tools, equipment and cargo come in all shapes and sizes and until now, there hasn't been a shelving unit that is truly adjustable. The ADseries is the first of it's kind where, with only a screwdriver, you can simply remove the front shelf bolts and move the shelf where you need it. Shelves can be adjusted in one inch increments and provide the most flexible shelving solution available.

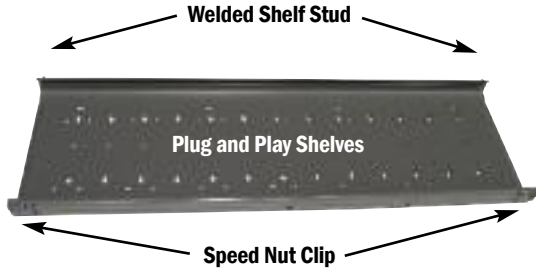

Truly Adjustable Shelves All you need is a phillips screwdriver! Simply remove two bolts from the speed nut clips that come with the shelf, tilt the shelf upwards, move the shelf to your desired location, insert the rear shelf studs, reattach the bolts and you're done!

Rear Shelf Studs unique design lock shelves in place!



ADAPTABLE INTERIOR

Everyone likes to set their work van up their own way. The new ADseries shelving lets you position the shelving where you need it. Exclusive to the ADseries, the unique rail system enables you to reposition the shelving in the van, increasing the available space for trade specific equipment. All of this is done without removing bolts, plugging holes and redrilling the van!

ADD ACCESSORIES

Businesses change over time and your van interior should be able to change with your needs. Plug and Play shelves have prepunched holes that allow adding storage solutions easily! ADseries dividers simply snap in place, drawer units simply bolt in and door kits can be added to lock your more valuable parts and equipment. Many Adrian Steel accessories can be added to the ADseries shelving with the rail adapter kits and end panel brackets.



ADseries Shelf Units and Rail Kits

| Model | Size | Description |
|---------|--------------------|----------------|
| AD26LCV | 26"W x 50"H x 14"D | fits Nissan NV |
| AD32LCV | 32"W x 50"H x 14"D | fits Nissan NV |
| AD44LCV | 44"W x 50"H x 14"D | fits Nissan NV |
| AD50LCV | 50"W x 50"H x 14"D | fits Nissan NV |
| RKLCV | Rail System | fits Nissan NV |

ADseries Accessories

| Model | Size/Description |
|----------|---|
| DV14C1 | Divider for ADseries/Single |
| DV14C8 | Divider for ADseries/8 Pack |
| DK3008 | 8" High Door Kit/AD32LCV |
| DK3010 | 10" High Door Kit/AD32LCV |
| DK4208 | 8" High Door Kit/AD44LCV |
| DK4210 | 10" High Door Kit/AD44LCV |
| DK4808 | 8" High Door Kit/AD50LCV |
| DK4810 | 10" High Door Kit/AD50LCV |
| BRK14EPS | End Panel Bracket To Add on Accessories |
| RKA1 | Rail Kit Adapter/See list at right |
| RKA3 | Rail Kit Adapter3/See list at right |
| RKA4 | Rail Kit Adapter4/See list at right |
| RKABRK1 | Rail Kit Adapter/End Panel Bracket/See list |
| RKABRK2 | Rail Kit Adapter/17A |
| RKAWTR | Rail Kit Adapter/Welded Tank Racks |
| RKA919 | Rail Kit Adapter/#9, #19, #919 Drawer Units |
| 35325-G | 32" Long Shelf |
| 35327-G | 44" Long Shelf |
| 35328-G | 50" Long Shelf |

RKA1 – Rail Adapter Kit1
Use with: CB2, CB3, CB4 (uses 2)

RKA3 – Rail Adapter Kit3
Use with: #1, #1.2, #2, #8, DC Units, 17A, CRH2, TA19, TA5

RKA4 – Rail Adapter Kit4
Use with: 17A, CB5, 43, TA19, KDRH2, KD Shelving Units, #33, #3, #33W, JD Shelving

BRK14EPS – ADseries end panel accessory attachment bracket.
Use with: 17A, CB5, 43, TA19, TA20, WRH5, UH10/25/50, PA9, PA8, ACT3/4, PA11, AGSCH2, PA7, TH30, TH50, TA5

RKABRK1 – Used with TA19, TA20, TA5

Note: Rails are not included with the shelf units. Rail kits must be ordered separately

Note: Shelves have the following weight rating:

Shelves positioned with the shelf lips facing up have a rating of 100lbs per shelf evenly distributed.

Shelves positioned with the shelf lips facing down have a rating of 200lbs per shelf evenly distributed.

PARTITIONS

ADRIAN STEEL PARTITIONS KEEP CARGO WHERE IT BELONGS, IN THE CARGO AREA!

Stamped steel partitions are available for the standard and high roof Nissan NV vans. The perforated panels allow for side and rear visibility, while increasing cab area climate control. Max Comfort Wing Kits allow for 3 inches of additional front seat adjustability for more cab and leg room. Partition accessories can be attached for easy reach.



Shown:
S1M2C2FSV
High roof partition
with WKC1LCVH
wing kit.

S-M-C Series Partitions

Choose from solid or perforated top panels made from 18-gauge steel for strength and finished in a tough Steel-Cote powder coat paint. Center M panels can be fixed or hinged with a key-locking door. Partitions are sold as panel kits and wing kits. Please see application chart to confirm the appropriate panel kit and wing kit for your vehicle. Partition panel kits and wing kits include assembly and installation fasteners for base van trim level. Higher trim levels may require modifying trim or partition.

Note: Extended wing kits reduce the amount of cargo space. Please confirm the interior layout of the van package to confirm that the extended wing kit has adequate room needed for installation.

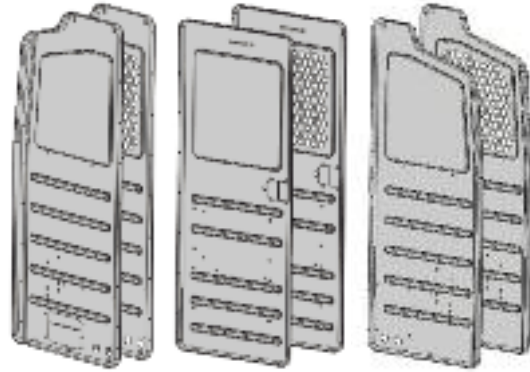

S1 Solid
S2 Perforated Top
Panels mount
behind driver
seat.

M1 Solid
M2 Perforated Top
Fixed center
panels can be
hinged as key-
locking doors

C1 Solid
C2 Perforated top
Panels mount
behind
passenger seat.



Max Comfort Wing Kit

Partition setback allows for 3" of additional front seat adjustability for more cab and leg room. (Reduces cargo space by 3".)



Shown:
S1M2C2FSV
Standard roof partition
with WKC1LCVS
wing kit.

Panel Kit Part Number

Fixed Center Panel

SOLID PANELS
S1M1C1FSV

CENTER PANEL PERF. TOP ONLY
S1M2C1FSV

PERF. CENTER & CURB PANELS
S1M2C2FSV

ALL PANELS PERFORATED
S2M2C2FSV

Hinged Center Panel "Door"

SOLID PANELS
S1M1HC1FSV

CENTER PANEL PERF. TOP ONLY
S1M2HC1FSV

PERF. CENTER & CURB PANELS
S1M2HC2FSV

ALL THREE PANELS PERFORATED
S2M2HC2FSV

Wing Kits

STANDARD ROOF
WKC1LCVS - MAX CARGO
WKC1LCVS3 - MAX COMFORT

HIGH ROOF
WKC1LCVH - MAX CARGO
WKC1LCVH3 - MAX COMFORT

PARTITION ACCESSORIES

ADRIAN ACCESSORIES FULLY UTILIZE YOUR PARTITION SPACE.



CB2 Two Book File has hinged retaining straps. Mounts to floor or other horizontal surface. **Overall size: 6" W, 14" H, 9 3/4" D.**

PA7 Triangle Reflector Kit comes with a metal pocket holder, I.C.C. approved.

PA10 Practice Holder is a partition-mounted holder for forms, manuals or work related papers. **Overall size: 12" W, 7" H, 5" D.**

PA8 1-A: 10-BC Fire Extinguisher is a rechargeable, 2-1/2 lb. dry chemical extinguisher. Stops Class A, B and C fires. Complete with charge gauge and mounting bracket.

PDK1 Door Kit converts M-Series fixed center panel into hinged door with keyed slam latch. Includes two 6" hinges, bulb seal and a slam latch. These features reduce vibration noise.

Plexiglas Partition Cover Panels (not shown)

PA5-1 fits S panel

PA5-2 fits M panel

PA5-6 fits C panel

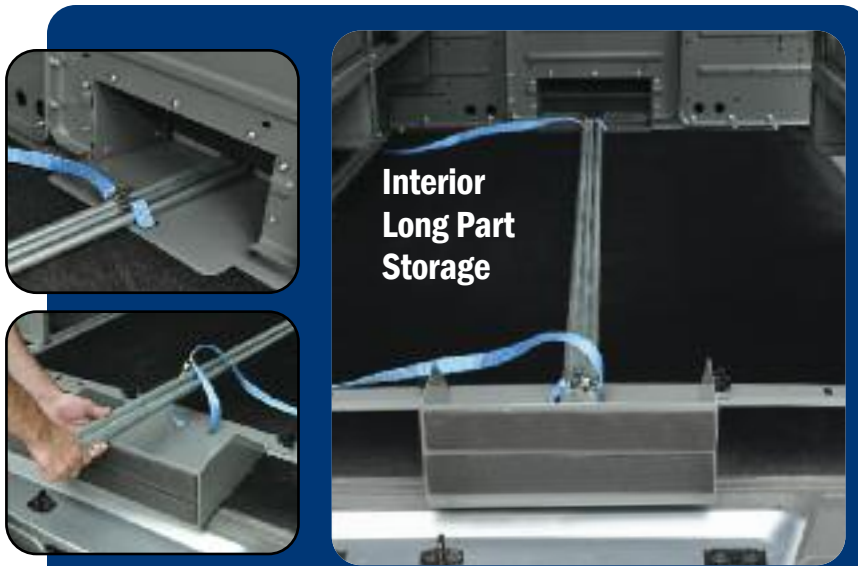

Interior Long Part Storage

Carry 10 feet of conduit or pipe inside your NV with the Long Part Storage Kit!

The modified middle partition panel has an extended box which has a 13 3/4" wide by 5 3/4" high opening in the M panel. Tie down straps are provided at the front and the rear of the product to secure the load. The rear tray is positioned to contain the cargo and protect the rear doors. Fits late model Adrian Steel SMC partitions only. Not compatible with hinged door partition option.

| Model | Description |
|-----------|---|
| M1FLP | M1 panel w/Long Parts Storage Kit |
| M2FLP | M2 panel w/Long Parts Storage Kit |
| S1M1C1FLP | S1M1C1 Panel Kit w/Long Parts Storage Kit |
| S1M2C1FLP | S1M2C1 Panel Kit w/Long Parts Storage Kit |
| S1M2C2FLP | S1M2C2 Panel Kit w/Long Parts Storage Kit |



TA1 Hook Bar maximizes vertical storage space. 2" x 12" bar mounts to partition or other vertical surfaces. Four welded hooks with 2" hanger opening.



File Management for Important Documents
PA11 Cab File Box mounts to partition or other vertical surface.
Overall size: 14" W, 10-1/2" H, 3-1/2" D.



TH30 Refrigerant Tank Holder 30 lb.-holds tank to partition or other vertical surface.

TH50 Refrigerant Tank Holder 50 lb.-holds tank to partition or other vertical surface.



PA9 First Aid Box Tray secures first aid box to partition or other vertical surface.
Overall size: 9" W, 3-1/2" H, 3" D

CABINET MODULES

SPECIFIC JOBS DEMAND SPECIFIC STORAGE SOLUTIONS.

Cabinet and Drawer Modules provide secure storage for large and small tools and parts. The modular design allows you to get what you need now and the ability to add more when you need it. What ever the job demands, Adrian has the storage solutions to transport your gear safely and securely.



Tank Cabinets

- Provide vented storage for Propane, Mapp gas or CO2 tanks.
- Cabinets feature a full door gasket with two snap latches for positive door closure.
- Interior cabinet cradle and retaining straps (foam yokes for TA19) secure tanks and prevent movement.
- Floor vent and tubing are included for exhausting fumes.
- Propane cabinets store 20, 30 or 40 lb. tanks.
- Mapp Gas Cabinets store 6 1/2" diameter tanks.
- CO2 Tank Cabinets store 20 lb. cylinders.

| Model | Description | Cabinet Size |
|-------|------------------|------------------------|
| TA18 | Propane Cabinet | 14-3/4"W x 36"H x 13"D |
| TA19 | CO2 Tank Cabinet | 13"W x 32"H x 12-1/2"D |
| TA20 | Mapp Gas Cabinet | 14"W x 26"H x 8"D |

Vented gas storage solutions



Folding T handles don't stick out into aisles.

Shelf Cabinets

- Available in 12" and 18" front to rear lengths
- Can be used free standing or stacked with our lockable drawer units.
- Feature locking recessed tee-handles for secure storage and receive a durable gray powder coat finish.
- Cabinets feature an open side and can be combined for side-by-side use holding items up to 35" long.
- Optional end panel can be added to close off side when required.
- Include an adjustable shelf that can be removed
- Optional foam liner kits can be added for extra protection and vibration reduction.
- Cabinets provide a solid surface to stack modular drawers, cabinets and bins.

| Model | Description | Cabinet Size |
|-------|-------------------------|--------------------|
| 1 | Shelf Cabinet | 18"W x 22"H x 18"L |
| 12 | Shelf Cabinet Open Side | 18"W x 22"H x 12"L |
| 1A | Optional Shelf | No. 1 |
| 12A | Optional End Panel | No.12 |
| FL1 | Optional Foam Kit | No. 1 |
| FL12 | Optional Foam Kit | No. 12 |



Cabinet Lockers

- Full-door Lockers feature a 46" high storage space with 3 removable shelves.
- Short-door Lockers feature a 33" high storage area and with 2 removable shelves.
- Locker doors are reversible for flexibility and feature locked recessed T-handles for security.
- Cabinet Lockers taper from 14" to 12" from front to back in depth at top and bottom to maximize aisle space.

| Model | Description | Cabinet Size |
|---------|---------------------------|--------------------|
| CL1446R | Cabinet Locker Full Door | 18"W x 46"H x 14"D |
| CL1446D | Cabinet Locker Short Door | 18"W x 46"H x 14"D |

DRAWER MODULES



2-1/2" deep drawers come with ABS divided and removable trays perfect for small parts.



Latched & Locked

Latched & Unlocked

Drawers Unlatched

Drawers Open

Drawer Units - Lock 'n Latch System

- Our exclusive Lock 'n Latch system provides a choice of drawers open, drawers retained or drawers locked position.
- Steel outer cabinet measures 18"W x 12"H x 12"L.
- Drawers are made of an engineered composite material for durability with heavy-duty drawer glides for support and smooth drawer operation.
- Drawers and glides can be repositioned within cabinet for increased flexibility.
- Divide 5" deep drawers into compartments using optional metal "egg crate" dividers.
- Optional Fitted Foam Kits cover side and bottom of 5" drawers for extra protection.

| Model | Description | Drawer Size (Qty.) |
|-------|------------------|--|
| 19 | 2 Drawer Medium | 16"W x 5"D x 11-1/2"L (2) |
| 919 | 3 Drawer Combo | 16"W x 2-1/2"D x 11-1/2"L (2) 16"W x 5"D x 11-1/2"L (1) |
| 9 | 4 Drawer Shallow | 16"W x 2-1/2"D x 11-1/2"L (4) |
| 27 | Divider Kit | Nos. 19 or 919 Drawer (1) |
| | | 13-3/4"W x 2-3/4"H x 11-3/4"L |
| FL19 | Foam Liner Kit | No. 19 Drawer (1) or 919 Drawer (1) |

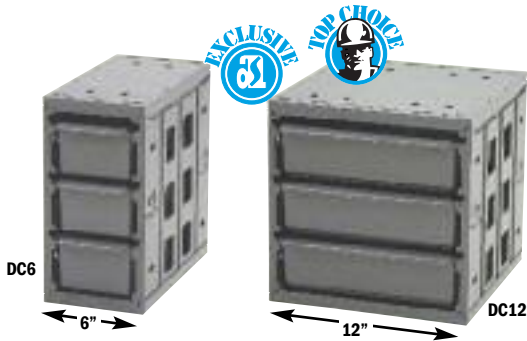

Drawer Components

- Organize small parts with our flexible and rugged composite Drawer Components.
- Drawer retention stops prevent drawers from opening while the vehicle is in transit.
- The interlocking feature allows you to add multiple units vertically or horizontally.
- Made of a hi-impact polymer for a quiet operation.
- Each drawer comes with 2 dividers and 7 divider slots.
- Choose from Adrian Steel's pre-configured drawer systems or create your own drawer system from the base models.

| Model | Description | Overall Size |
|----------|----------------------------|--------------------|
| DC6 | Base 3 drawer narrow model | 6"W x 12"H x 12"D |
| DC12 | Base 3 drawer wide model | 12"W x 12"H x 12"D |
| DS06212V | Drawer System (2) DC12's | 12"W x 24"H x 12"D |
| DS36012H | Drawer System (3) DC6's | 18"W x 12"H x 12"D |
| DS46012 | Drawer System (4) DC6's | 12"W x 24"H x 12"D |

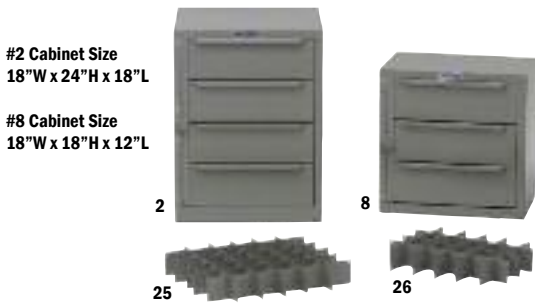

#2 Cabinet Size
18"W x 24"H x 18"L

#8 Cabinet Size
18"W x 18"H x 12"L

Drawer Units - Locking Hinge and Hasp

- Drawers are welded and have reinforced drawer slides for strength.
- Can be locked with a padlock (not included) for security.
- Divide drawers with optional metal "egg crate" dividers.
- Optional Foam Liner Kits cover sides and bottom of drawers for extra protection.

| Model | Description | Drawer Size (Qty.) |
|-------|-----------------|---|
| 8 | 3 Drawer Medium | 16"W x 5"D x 11-1/2"L (3) |
| 2 | 4 Drawer Medium | 16"W x 5"D x 17-1/2"(4) |
| 25 | Divider Kit | No. 2 Drawer (1) 15-1/2"W x 2-3/4"H x 17-1/2"L |
| 26 | Divider Kit | No. 8 Drawer (1) 15-1/2"W x 2-3/4"H 11-1/2"L |
| FL2 | Foam Liner Kit | No. 2 Drawer (1) |
| FL8 | Foam Liner Kit | No. 8 Drawer (1) |



Portable trays

Tote Trays and Cases

- Take small parts and tools right to the job site with removable tote trays and cases.
- Totes measure 18-1/2"W x 3"D x 12-1/2"L and are available in both steel tray and poly case designs.
- Steel tote trays feature fold-down carry handles and four large storage compartments with adjustable dividers.
- Poly tote cases offer a see-through lid with latches to prevent spilling,, four large compartments and twelve adjustable dividers.
- Trays and cases store in a 19-3/4"W x 20-1/8"H x 13-3/8"L modular rack that can be stacked or floor mounted.

| Model | Description | Tote Style (Qty.) |
|--------|-----------------------|--------------------------------|
| SPT-4 | Combo Totes and Rack | Steel Trays (2) Poly Cases (2) |
| SPT-4P | Poly Totes and Rack | Poly Cases (4) |
| SPT-4S | Steel Totes and Rack | Steel Trays (4) |
| SPT-S | Additional Steel Tray | |
| SPT-P | Additional Poly Tote | |

VAN ACCESSORIES



ADRIAN'S BLUE BIN SYSTEM IS PERFECT FOR VISUAL INVENTORY MANAGEMENT.

- 6" and 12" bins maximize the ADseries shelf space.
- The innovative rail system locks the bins in place on the shelf.
- The bins can nest on top of each other when at the job site or in the warehouse getting filled to go.
- Add a label to the front so you can find parts quickly
- Each bin can accommodate one optional divider.

Order our predefined bin systems or create your own configuration of bins. Please note that the bins and the rail are a system. To obtain all the features listed above, both must be ordered.



SBIN120614



SBIN060614



BR36212 Bin System on an AD44LCV ADseries shelf unit.



Bins lock into place along the rail for secure transport.

SAFELY TRANSPORT REFRIGERANT TANKS.



Freon Tank Holder TH51FP

Accommodates a combination of any three 30 or 50 lb tanks.

Straps secure tanks for safe transportation.

Blue Bin Systems

| Model | Description |
|------------|--------------------------------------|
| SBIN060614 | 6" Blue Bin |
| SBIN120614 | 12" Blue Bin |
| SBINDIV | Divider |
| BR36212 | Bin System: 3-6" & 2-12" bins w/rail |
| BR76012 | Bin System: 7-6" bins with rail |
| SRAILAD26 | 26" Retention rail |
| SRAILAD32 | 32" Retention rail |
| SRAILAD44 | 44" Retention rail |
| SRAILAD50 | 50" Retention rail |



1: CB5 Five Slot Literature Holder Mount on partition or other vertical surface. 2-1/2" deep pockets. Overall size: 12"W, 24"H, 2-1/2"D.

2: CB7 Seven Slot Literature Holder Mount on partition or other vertical surface. 6-3/4" deep pockets. Overall size: 14-3/4"W, 28-7/8"H, 7"D.

3: 17A Six Shelf Catalog File Designed for catalogs but also serves to store a variety of materials between the 3" shelf spacings. Overall size: 11"W, 24"H, 12"D.

4: 43 Three Shelf Catalog File Fits in narrow spaces. It has three tilted shelves. Perfect for binders and catalogs. Overall size: 6" W, 34" H, 12" D.

4: BH4 Four Slot Binder Holder Designed to mount on partition or almost any vertical surface. Excellent for binders. Each pocket is 2 1/2" deep.

Overall size: 12-3/4" W, 19-1/2" H, 2-1/2" D.

5: CB2 Two Book File Mounts on the floor between front seats and partition. Holds folders 12"H x 10-1/2"D. Overall size: 6"W, 14"H, 12"D.

6: CB3 Three Book File Mounts on cabinet tops or on the floor. Multiple units can be flush-mounted. Holds folders 12"H x 10-1/2"D.

Overall size: 10-3/4"W, 14"H, 12"D.

7: CB4 Utility Storage Box Stores a variety of printed material. Also suitable for keeping tools, safety glasses, gloves and other items. Hinged lid. Overall size: 12"W, 12"H, 14"D.

VAN ACCESSORIES



1: DST21 Door Storage Tray offers convenient access to parts and tools.

Overall size: 20" W, 4" D, 8" H

2: Aerosol Can Tray secure cans for easy access.

ACT3 - 3 Can Tray Overall size: 11-3/4" W, 4" D, 6-3/4" H

ACT4 - 4 Can Tray Overall size: 15-7/16" W, 4" D, 6-3/4" H

3: 14 Step Stool has a wide base and is 12" high. Stool can be used as a workbench or auxiliary step. Top measures 10" x 20" One size.

4: TA2 Hard Hat Holder secures hat to partition or shelving.

5: TA3 Saw Holder holds two hand saws.

6: VMA36 Vise Mount Assembly is floor mounted and telescopes out beyond side or rear cargo doors when fully opened. Measures 36" closed and 60" open.

7: Touch-Up Paint in spray cans match Steel-Cote™ finish. Three colors:

STP12G - Gray **STP12W** - White **STP12B** - Black

8: Door Tray comes with two dividers and has optional lid for containment.

DT21 - Door Tray Overall size: 18" W, 4" D, 4" H

DTL21 - Door Tray Lid for DT21 only

DTWL21 - Door Tray with Lid Overall size: 20" W, 4" D, 4" H

9: Parts Tray features a 2" deep shelf lip. Can be mounted to cabinet and drawer modules for added top storage.

4A - Parts Tray Overall size: 36" W, 12" D, 2" H

4B - Parts Tray Overall size: 18" W, 12" D, 2" H



Storage for small parts

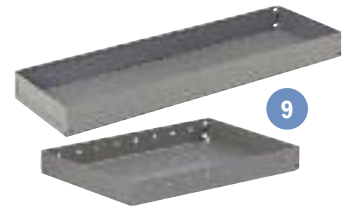

REEL HOLDERS

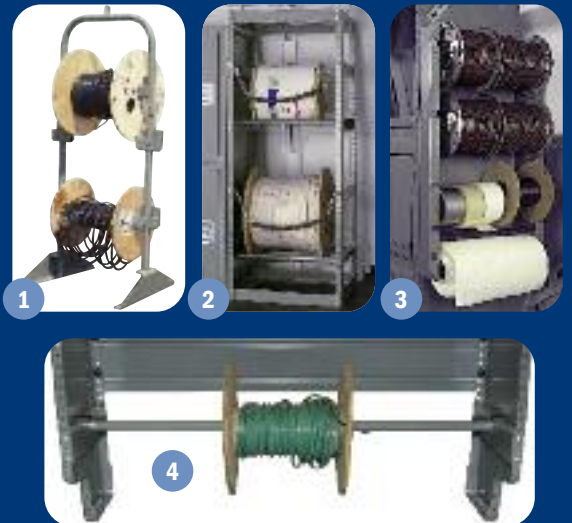

1: CRH2 Cable Reel Holder features a durable frame, two steel shafts that holds up to a 15-1/2" diameter reel by 14" wide. Overall size: 19-1/8" W, 16" D, 44-7/8" H

2: KDRH2 Cable Reel Holder holds large spools up to 16" wide and 18" in diameter. Spools nest on conveyor rollers. Includes tie-down chains with neoprene covers. Overall size: 18" W, 46" H, 18" D

3: WRH5 Wire Reel Holder Five removable bars hold wire spools up to 6" in diameter. Reel Holder mounts to shelf ends or any vertical surface. Overall size: 12" W, 25" H, 4" D

4: End Panel Reel Holder Bar mounts between ADseries shelf end panels for easy access to spools of cable and wire.

KDRH1426 - fits 26" shelf
KDRH1444 - fits 44" shelf

KDRH1432 - fits 32" shelf
KDRH1450 - fits 50" shelf

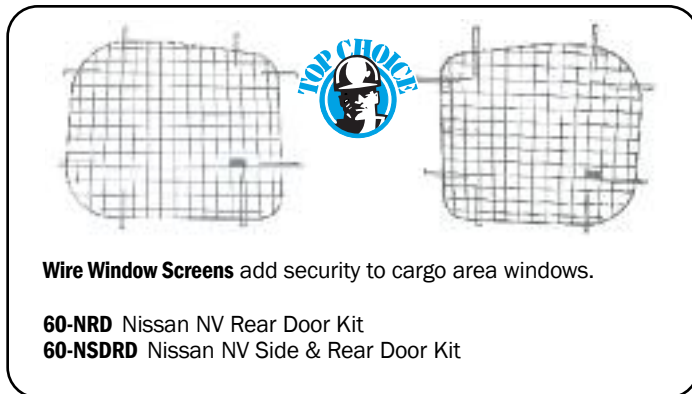

Wire Window Screens add security to cargo area windows.

60-NRD Nissan NV Rear Door Kit

60-NSDRD Nissan NV Side & Rear Door Kit

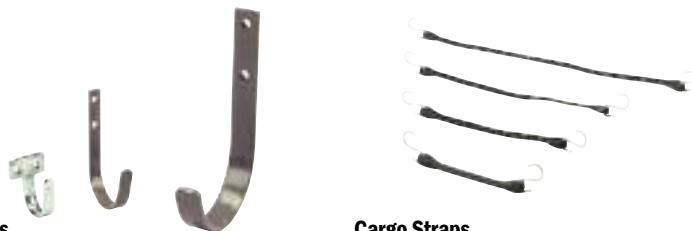

Hooks

| Model | Description |
|-------|-------------|
| UH10 | 1" hook |
| UH25 | 2-1/2" hook |
| UH50 | 5" hook |
| TA1 | 4 Hook Bar |

Cargo Straps

| Model | Description |
|-------|-------------|
| CS9 | 9" strap |
| CS15 | 15" strap |
| CS21 | 21" strap |
| CS31 | 31" strap |

STANDARD ROOF LOADSRITE DROP-DOWN LADDER RACK

LOADING LADDERS JUST GOT DOWN RIGHT EASY.

Adrian's LOADSRITE Ladder Racks easily raise and lower to eliminate the need to climb, stretch or reach for your ladder on top of your NV. The unique design of the LOADSRITE presents the ladder in a diagonal position bringing it to a comfortable working height.



1. Easy Reach Handle

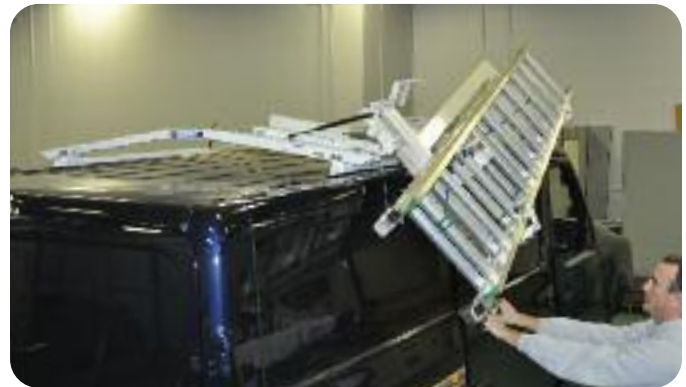

3. Hydraulic Load Assist



2. Glide-Out Bed Platform

LOADSRITE
Keeps loading and
unloading from being
a pain in the back.



HIGH ROOF LOADSRITE DROP-DOWN LADDER RACK

LOADSRITE FEATURES & BENEFITS

- Designed to allow ladders to be loaded and unloaded one end at a time.
- Ladder clamps securely hold the ladder for transportation.
- Ladders can be padlocked for added security.
- Clamping of ladder is automatic.
- Aluminum bed frame, cast aluminum grab handle, stainless steel latch and fasteners.
- Rollers and dampers create a smooth transition to the stowed and down positions.
- The easy-reach release handle lowers toward the ground for better access (high roof.)
- Two handed operation is required to release the ladder for safer loading and unloading.
- Plastisol clamps and plastic pads protect fiberglass ladders.
- The LoadsRite for the Nissan NV can carry 16' - 36' extension ladders

LCVLR-S61 Single LoadsRite (curbside) -std. roof

LCVLR-S63 Double LoadsRite -std. roof

LCVLR-H61 Single LoadsRite (curbside) -high roof

LCVLR-H63 Double LoadsRite -high roof



1. Rotate Handle



2. Primary Drop



3. Secondary Drop



4. Unload Ladder



**See the
LOADSRITE
in action on
the web.**

UTILITY RACKS

MAKE YOUR NISSAN NV EVEN MORE VERSATILE WITH ADRIAN STEEL UTILITY RACKS.

The Utility Rack features an all aluminum design that allows you to maximize the cargo capacity of the Nissan NV. It provides a flat surface to transport a sheet goods, ladders, conduit, lumber and more safely on the roof of your Nissan NV. Choose between black or white powder coat finish. The Nissan NV can accommodate 2-5 cross bars.



UTILITY RACK FEATURES & BENEFITS

- Designed to reduce corrosion by eliminating much of the welding.
- The uprights are fully plastisoled to protect against wear and reduce ladder fatigue.
- Uprights feature a number of attachment points for securing cargo straps.
- Weather resistant cross bar is not cut to fit or perforated in any way improving longevity of the rack.
- Available in our durable black or white powder coat paint.
- Optional center bars support shorter lengths and provides additional support.

| Model | Description | Color |
|----------|--------------------|-------|
| 3BNLCV-B | 3 Bar Utility Rack | Black |
| 3BNLCV-W | 3 Bar Utility Rack | White |
| 2BNLCV-B | 2 Bar Utility Rack | Black |
| 2BNLCV-W | 2 Bar Utility Rack | White |
| 1BNLCV-B | 1 Crossbar | Black |
| 1BNLCV-W | 1 Crossbar | White |

ALUMINUM CONDUIT CARRIER

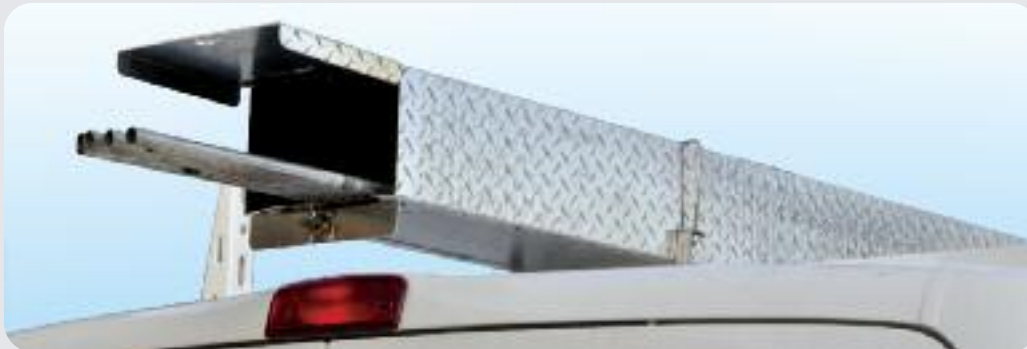

80-1
10'6" Aluminum
Conduit Carrier

80-2
12'6" Aluminum
Conduit Carrier

Transport conduit safely on the top of your standard roof NV. The Aluminum Conduit Carrier's two piece design features a lift-up door with a spring assist for easy access and lockable swivel closure for security. Constructed with .063" diamond tread aluminum with a bolt-on plate at the front to allow access to the front end of the carrier.

LADDER KEEPER

STORING LADDERS INSIDE YOUR NV IS EASY AS 1, 2, 3, WITH OUR LADDER KEEPER.

Ladder Keeper is designed to be loaded from outside the vehicle, the Ladder Keeper features a spring-loaded clamp that holds the ladder securely in place. Just set the top of the ladder in the front clamp bracket and push it forward until the bottom of the ladder sits in the rear clamp bracket. Mounts to the ceiling of the NV to securely transport ladders inside and out of the elements. Includes all parts needed to carry up to a 6 foot ladder.

LKLCV - Ladder Keeper Interior Ladder Rack for Nissan NV



1 Simply press ladder inward to release rear ladder rung from the rear clamp bracket.



2 Walk the ladder back as the front clamp bracket glides on the track.



3 Remove front rung from the front clamp bracket and you're ready to go to the job site!



- A** Plastic coated clamps protect ladder rungs
- B** Gas spring compresses ladder for quiet and secure transportation
- C** Extruded track makes loading and unloading simple

CARGO MANAGEMENT UPFITS

STORAGE SOLUTIONS THAT STAND UP TO THE JOB.

The Cargo Management System features ultimate flexibility with adjustable shelving that can be configured for what you need today and adjusted for what you need down the road. Complete the package with drawer units, door kits, dividers and hooks to organize your interior, a ladder or utility rack for your roof, and a graphic to turn your vehicle into a rolling billboard for your business.

CARGO MANAGEMENT SYSTEM:

4484 Standard Roof
4519 High Roof

| Item | Model | Description | Qty. |
|------|-------------------------|---|------|
| 1 | S1M2C2FSV | Partition | 1 |
| 2 | AD44LCV | ADseries shelving Unit | 3 |
| 3 | TA1WAD | Four Hook Bar | 1 |
| 4 | WKC1LCVH or WKC1LCVS | Partition wing kit - high roof Partition wing kit - std roof | 1 |
| 5 | RKLCV | Rail Kit | 1 |



STANDARD ROOF

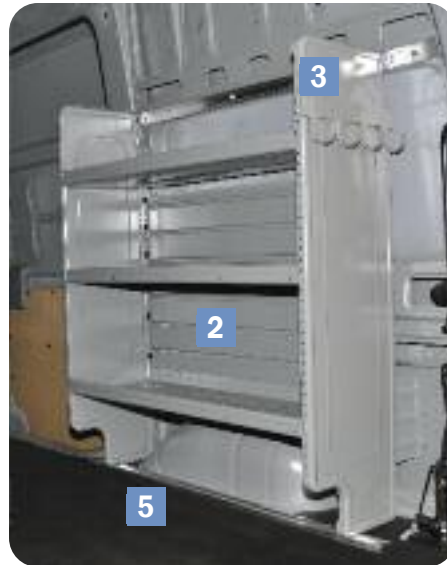

HIGH ROOF

Graphic designed with:



Make hundreds of impressions where ever your work takes you with a graphic van wrap from Commercial Curb Appeal!



GENERAL SERVICE UPFITS

STORAGE SOLUTIONS THAT STAND UP TO THE JOB.

General Service upfits feature drawers for small parts storage, open shelving and removable bins for customizable storage. Hooks on the end panels allow for easy access to cords and tools from the rear doors. Wrap it up with a custom graphic from Commercial Curb Appeal and advertise your services day and night!

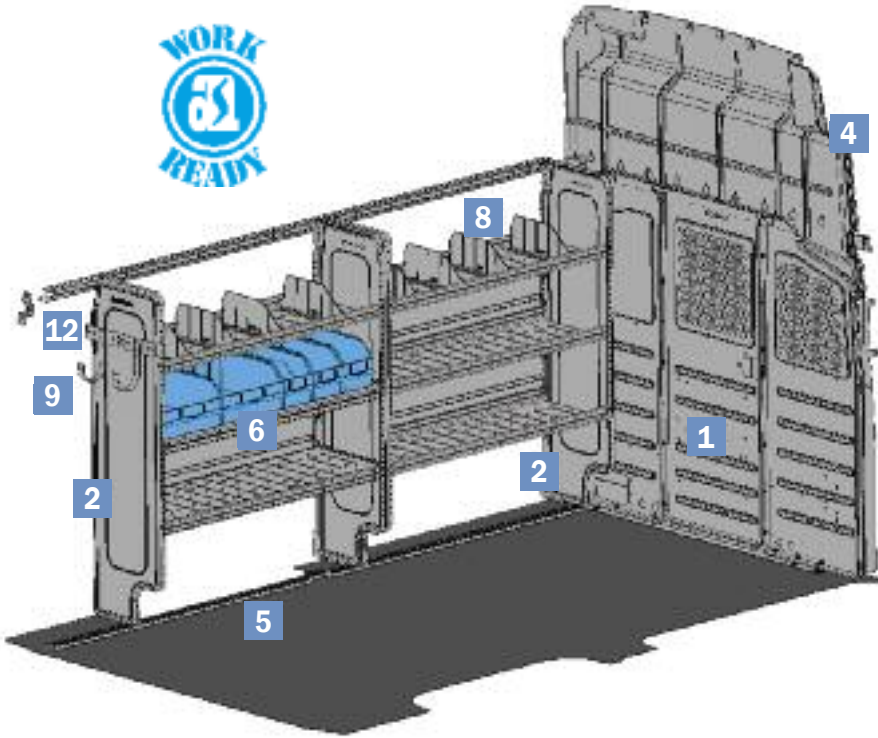

GENERAL SERVICE PACKAGE:

4686NS Standard Roof
4686NH High Roof

| Item | Model | Description | Qty. |
|------|-------------------------|---|------|
| 1 | S1M2C2FSV | Partition | 1 |
| 2 | AD44LCV | ADseries Shelving Unit | 3 |
| 3 | TA1WAD | Four Hook Bar | 1 |
| 4 | WKC1LCVH or WKC1LCVS | Partition wing kit - high roof Partition wing kit - std roof | 1 |
| 5 | RKLCV | Rail Kit | 1 |
| 6 | BR36212 | Parts Bin System (3-6", 2-12") | 1 |
| 7 | DC6 | Drawer Component 6" | 1 |
| 8 | DV14C1 | Divider | 8 |
| 9 | UH50 | 5" Hook | 2 |
| 10 | 19 | Two Drawer Medium | 1 |
| 11 | 9 | Four Drawer Shallow | 1 |
| 12 | BRK14EPS | End Panel Bracket | 1 |

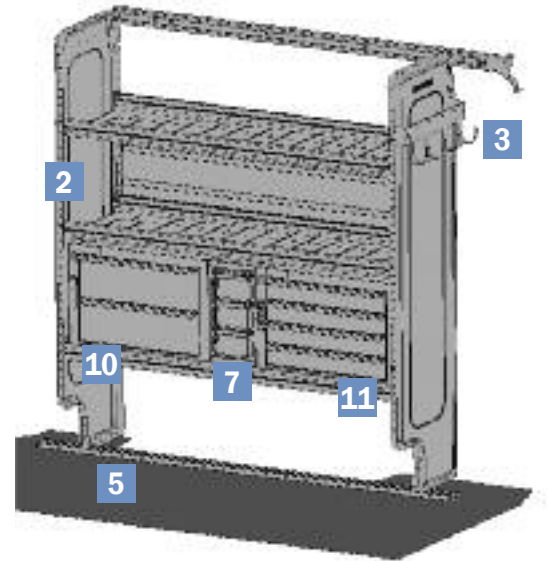

**Feel like you already work 24/7?
You may not be able to but your NV can with a graphics package advertising you!**

Graphic designed with:



Make your NV WORK READY with a drop-down ladder rack or versatile cargo rack.



pages 14-15

ELECTRICAL CONTRACTOR & SECURITY UPFITS

KEEP EVERYTHING IN ITS PLACE AND EASILY ACCESSIBLE.

Time is money, and no one wants to pay you to dig through your NV to find the parts and tools you need to do the job. Divided shelving and composite drawers are perfect for keeping small components organized and in place. Work ready van upfits are designed for service technicians who need to make fast and efficient service and installation calls. And, we don't want you to wait either, so get your interior, ladder rack and graphics wrap all done at one place.

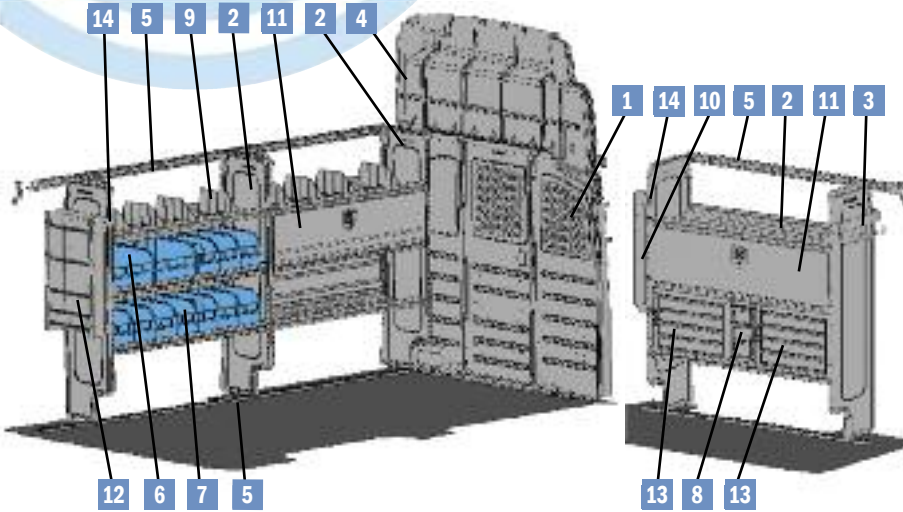

ELECTRICAL CONTRACTOR PACKAGE:

4687NS Standard Roof NV
4687NH High Roof NV

| Item | Model | Description | Qty. |
|------|-------------------------|---|------|
| 1 | S1M2C2FSV | Partition | 1 |
| 2 | AD44LCV | ADseries Shelving Unit | 3 |
| 3 | TA1WAD | Four Hook Bar | 1 |
| 4 | WKC1LCVH or WKC1LCVS | Partition wing kit - high roof Partition wing kit - std roof | 1 |
| 5 | RKLCV | Rail Kit | 1 |
| 6 | BR36212 | Parts Bin System (3-6", 2-12") | 1 |
| 7 | BR76012 | Parts Bin System (7-6") | 1 |
| 8 | DC6 | Drawer Component 6" | 1 |
| 9 | DV14C1 | Divider | 8 |
| 10 | CB5 | Five Slot Literature Rack | 1 |
| 11 | DK4210 | Door Kit | 2 |
| 12 | WRH5 | Wire Reel Holder | 1 |
| 13 | 9 | Four Drawer Shallow | 2 |
| 14 | BRK14EPS | End Panel Bracket | 4 |

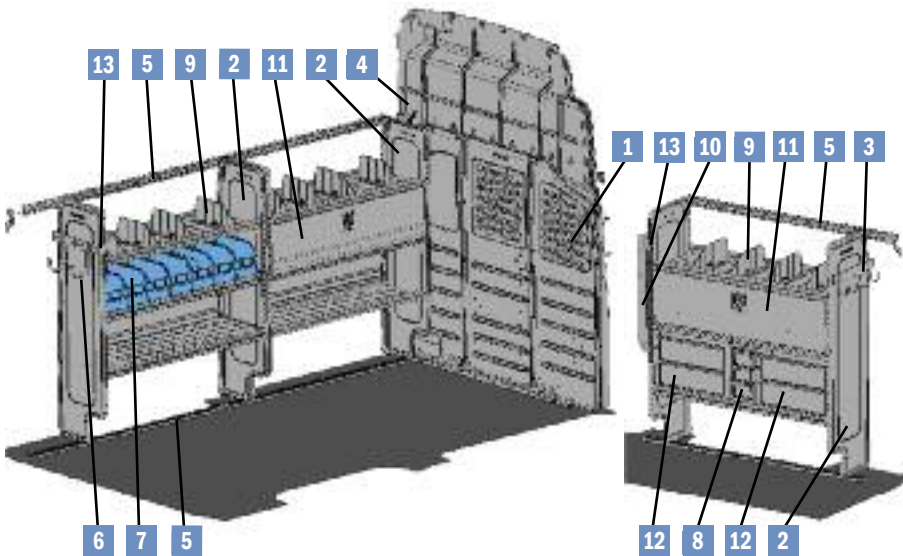

SECURITY PACKAGE:

4688NS Standard Roof NV
4688NH High Roof NV

| Item | Model | Description | Qty. |
|------|-------------------------|---|------|
| 1 | S1M2C2FSV | Partition | 1 |
| 2 | AD44LCV | ADseries Shelving Unit | 3 |
| 3 | TA1WAD | Four Hook Bar | 1 |
| 4 | WKC1LCVH or WKC1LCVS | Partition wing kit - high roof Partition wing kit - std roof | 1 |
| 5 | RKLCV | Rail Kit | 1 |
| 6 | UH50 | 5" Hook | 2 |
| 7 | BR76012 | Parts Bin System (7-6") | 1 |
| 8 | DC6 | Drawer Component 6" | 1 |
| 9 | DV14C1 | Divider | 12 |
| 10 | CB5 | Five Slot Literature Rack | 1 |
| 11 | DK4210 | Door Kit | 2 |
| 12 | 19 | Two Drawer Medium | 2 |
| 13 | BRK14EPS | End Panel Bracket | 3 |



Graphic designed with:



Feel safe knowing that you are actively promoting your brand whether you are at a jobsite or just parked at the office.

Electrify your brand with a rolling billboard from Commercial Curb Appeal!

CABLE TV & HVAC CONTRACTOR UPFITS

STORAGE SYSTEMS THAT ARE AS FLEXIBLE AS YOU ARE.

Is there anything that you don't have in the back of your NV? For all the parts and equipment that you need to transport, you need an Adrian Steel Work Ready Van with the trade specific equipment you'll use to do the job and a graphics package advertising the work you do.

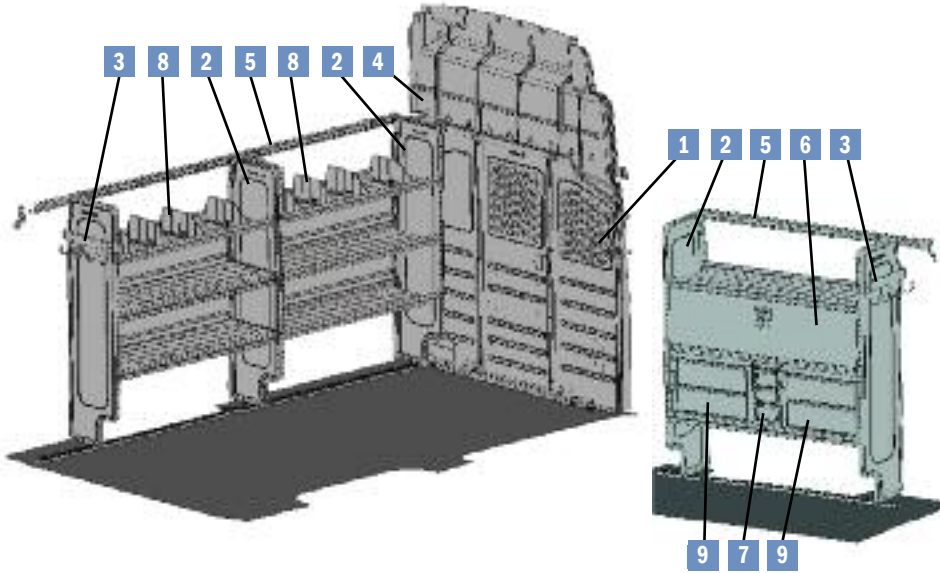

CABLE PACKAGE:

4689NS Standard Roof NV
4689NH High Roof NV

| Item | Model | Description | Qty. |
|------|-------------------------|---|------|
| 1 | S1M2C2FSV | Partition | 1 |
| 2 | AD44LCV | ADseries Shelving Unit | 3 |
| 3 | TA1WAD | Four Hook Bar | 2 |
| 4 | WKC1LCVH or WKC1LCVS | Partition wing kit - high roof Partition wing kit - std roof | 1 |
| 5 | RKLCV | Rail Kit | 1 |
| 6 | DK4210 | Door Kit | 1 |
| 7 | DC6 | Drawer Component 6" | 1 |
| 8 | DV14C1 | Divider | 8 |
| 9 | 19 | Two Drawer Medium | 2 |

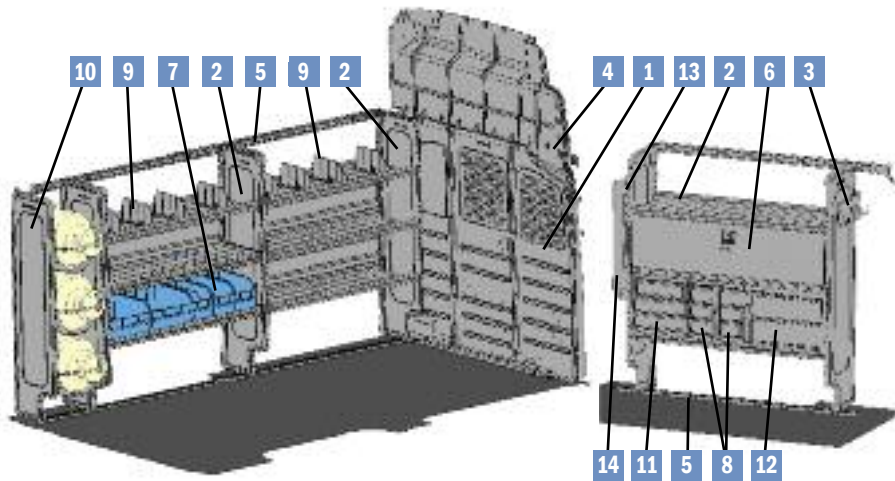

HVAC PACKAGE:

4690NS Standard Roof NV
4690NH High Roof NV

| Item | Model | Description | Qty. |
|------|-------------------------|---|------|
| 1 | S1M2C2FSV | Partition | 1 |
| 2 | AD44LCV | ADseries Shelving Unit | 3 |
| 3 | TA1WAD | Four Hook Bar | 1 |
| 4 | WKC1LCVH or WKC1LCVS | Partition wing kit - high roof Partition wing kit - std roof | 1 |
| 5 | RKLCV | Rail Kit | 1 |
| 6 | DK4210 | Door Kit | 1 |
| 7 | BR36212 | Parts Bin System (3-6", 2-12") | 1 |
| 8 | DC6 | Drawer Component 6" | 2 |
| 9 | DV14C1 | Divider | 8 |
| 10 | TH51FP | 3 Tank Rack | 1 |
| 11 | DC12 | Drawer Component 12" | 1 |
| 12 | 19 | Two Drawer Medium | 1 |
| 13 | BRK14EPS | End Panel Bracket | 2 |
| 14 | CB5 | Five Slot Literature Rack | 1 |

Graphic designed with:



COMMUNICATE YOUR BRAND!

If you make a living in a highly competitive market you must stand out from all the others. If your work speaks for itself, shouldn't your van speak for you too?

Get the attention you deserve with a vehicle graphics package from Commercial Curb Appeal!



800.677.2726

LOCKSMITH UPFITS

TRANSFORM YOUR NV INTO A MOBILE LOCKSMITH SHOP!

Arrive at your next jobsite in style with a work van that has the equipment you need and a colorful graphic telling everyone the work that you do. A workbench provides 84 inches of workspace and locking drawer units organize and secure small parts and tools. Add accessories to fit your specific storage needs.



LOCKSMITH PACKAGE:

2255NS Standard Roof
2255NH High Roof

| Item | Model | Description | Qty. |
|------|-------------------------|---|------|
| 1 | S1M2C2FSV | Partition | 1 |
| 2 | WKC1LCVH or WKC1LCVS | Partition wing kit - high roof Partition wing kit - std roof | 1 |
| 3 | RKLCV | Rail Kit | 1 |
| 4 | RKALCV | Rail Kit Adapter | 1 |
| 5 | MD506 | Drawer & Cabinet Module | 1 |
| 6 | MD608 | Workbench Module (18" x 26" x 84") | 1 |
| 7 | 17A | Six Shelf Literature File | 1 |
| 8 | TA1 | Four Hook Bar (not shown) | 1 |

MAKE IT A WORK READY VAN!

Day and night, you can lock in those leads with a vehicle graphic wrap from Commercial Curb Appeal.

Design your own look and have it installed at the same time as your interior!

Graphic designed with:



INDEX

| Model | Page | Description |
|-----------|------|---------------------------------|
| ACT3 | 13 | Aerosol Can Tray |
| ACT4 | 13 | Aerosol Can Tray |
| AD26LCV | 7 | 26" ADseries-Nissan |
| AD32LCV | 7 | 32" ADseries-Nissan |
| AD44LCV | 7 | 44" ADseries-Nissan |
| AD50LCV | 7 | 50" ADseries-Nissan |
| BH4 | 12 | Binder Holder |
| BR36212 | 12 | Bin System |
| BR76012 | 12 | Bin System |
| BRK14EPS | 7 | End Panel Bracket |
| CB2 | 9,12 | Two Book File |
| CB3 | 12 | Three Book File |
| CB4 | 12 | Utility Storage Box |
| CB5 | 9,12 | Literature Holder |
| CB7 | 12 | Literature Holder |
| CL1446D | 10 | Cabinet Locker |
| CL1446R | 10 | Cabinet Locker |
| CRH2 | 13 | Cable Reel Holder |
| CS9 | 13 | 9" Cargo Strap |
| CS15 | 13 | 15" Cargo Strap |
| CS21 | 13 | 21" Cargo Strap |
| CS31 | 13 | 31" Cargo Strap |
| DC6 | 11 | Drawer Component |
| DC12 | 11 | Drawer Component |
| DK4208 | 7 | 8" Door Kit |
| DK4210 | 7 | 10" Door Kit |
| DS06112V | 11 | Drawer System |
| DS36012H | 11 | Drawer System |
| DS46012 | 11 | Drawer System |
| DST21 | 13 | Door Storage Tray |
| DT21 | 13 | Door Tray |
| DTL21 | 13 | Door Tray Lid |
| DTWL21 | 13 | Door Tray w/Lid |
| FL1 | 10 | Foam Liner |
| FL2 | 11 | Foam Liner |
| FL8 | 11 | Foam Liner |
| FL12 | 10 | Foam Liner |
| FL19 | 11 | Foam Liner |
| KDRH1426 | 13 | End Panel Reel Holder |
| KDRH1432 | 13 | End Panel Reel Holder |
| KDRH1444 | 13 | End Panel Reel Holder |
| KDRH1450 | 13 | End Panel Reel Holder |
| KDRH2 | 13 | Reel Holder |
| LCVLR-H61 | 15 | Single LoadsRite - NV high roof |
| LCVLR-H63 | 15 | Double LoadsRite - NV high roof |
| LCVLR-S61 | 15 | Single LoadsRite - NV std roof |
| LCVLR-S63 | 15 | Double LoadsRite - NV std roof |
| LKLCV | 17 | Ladder Keeper - Nissan |
| M1FLP | 9 | Long Parts Storage, M1 |
| M2FLP | 9 | Long Parts Storage, M2 |
| PA5-1 | 9 | Plexiglas Panel |

| Model | Page | Description |
|------------|------|--------------------------------|
| PA5-2 | 9 | Plexiglas Panel |
| PA5-6 | 9 | Plexiglas Panel |
| PA7 | 9 | Reflector Flare Kit |
| PA8 | 9 | Fire Extinguisher |
| PA9 | 9 | First Aid Tray |
| PA10 | 9 | Practice Holder |
| PA11 | 9 | Cab File Box |
| PDK1 | 9 | Partition Door Kit |
| RKA1 | 7 | Rail Kit Adapter |
| RKA3 | 7 | Rail Kit Adapter |
| RKA4 | 7 | Rail Kit Adapter |
| RKABRK1 | 7 | Rail Kit Adapter |
| RKABRK2 | 7 | Rail Kit Adapter |
| RKA919 | 7 | Rail Kit Adapter |
| RKLCV | 7 | Rail System Nissan NV |
| S1M1C1FLP | 9 | Partition w/ Long Part Storage |
| S1M1C1FSV | 8 | Partition FSV |
| S1M1HC1FSV | 8 | Partition FSV |
| S1M2C1FLP | 9 | Partition w/ Long Part Storage |
| S1M2C1FSV | 8 | Partition FSV |
| S1M2HC1FSV | 8 | Partition FSV |
| S1M2C2FLP | 9 | Partition w/ Long Part Storage |
| S1M2C2FSV | 8 | Partition FSV |
| S1M2HC2FSV | 8 | Partition FSV |
| S2M2C2FSV | 8 | Partition FSV |
| S2M2HC2FSV | 8 | Partition FSV |
| SBIN060614 | 12 | 6" Plastic Bin |
| SBIN120614 | 12 | 12" Plastic Bin |
| SBINDIV | 12 | Plastic Bin Divider |
| SPT-4 | 11 | SP Tote/Combo |
| SPT-4P | 11 | SP Tote/Poly |
| SPT-4S | 11 | SP Tote/Steel |
| SPT-S | 11 | SPT Steel Tray |
| SPT-P | 11 | SPT Poly Tote |
| SRAILAD26 | 12 | Bin Retention Rail 26" |
| SRAILAD32 | 12 | Bin Retention Rail 32" |
| SRAILAD44 | 12 | Bin Retention Rail 44" |
| SRAILAD50 | 12 | Bin Retention Rail 50" |
| STP12G | 13 | Paint, Gray |
| STP12W | 13 | Paint, White |
| STP12B | 13 | Paint, Black |
| TA1 | 13 | Hook Bar |
| TA2 | 13 | Hard Hat Holder |
| TA3 | 13 | Saw Holder |
| TA18 | 10 | Propane Tank Cab. |
| TA19 | 10 | CO2 Tank Cabinet |
| TA20 | 10 | Mapp Gas Cabinet |
| TH30 | 9 | Tank Holder |
| TH50 | 9 | Tank Holder |
| TH51FP | 12 | Freon Tank Holder-Nissan |
| UH10 | 13 | Utility Hook |

| Model | Page | Description |
|-----------|------|-----------------------------|
| UH25 | 13 | Utility Hook |
| UH50 | 13 | Utility Hook |
| VMA36 | 13 | Vice Mount Assembly |
| WKC1LCVH | 8 | Wing Kit - Nissan High Roof |
| WKC1LCVH3 | 8 | Wing Kit - Nissan High Roof |
| WKC1LCVS | 8 | Wing Kit - Nissan Std Roof |
| WKC1LCVS3 | 8 | Wing Kit - Nissan Std Roof |
| WRH5 | 13 | Wire Reel Holder |
| 1 | 10 | Cabinet |
| 1A | 10 | Shelf |
| 1BNLCV-B | 16 | Crossbar/Black |
| 1BNLCV-W | 16 | Crossbar/White |
| 2 | 11 | Drawer Unit |
| 2BNLCV-B | 16 | 2 Bar Utility Rack |
| 2BNLCV-W | 16 | 2 Bar Utility Rack |
| 3BNLCV-B | 16 | 3 Bar Utility Rack |
| 3BNLCV-W | 16 | 3 Bar Utility Rack |
| 4A | 13 | Parts Tray |
| 4B | 13 | Parts Tray |
| 8 | 11 | Drawer Unit |
| 9 | 11 | Drawer Unit |
| 12 | 10 | Cabinet |
| 12A | 10 | End Panel |
| 14 | 13 | Step Stool |
| 17A | 12 | Catalog File |
| 19 | 11 | Drawer Unit |
| 25 | 11 | Divider/#2 |
| 26 | 11 | Divider/#8 |
| 27 | 11 | Divider/#19 |
| 43 | 12 | Catalog File |
| 60-NRD | 13 | Window Screen |
| 60-NSDRD | 13 | Window Screen |
| 80-1 | 16 | Conduit Carrier |
| 80-2 | 16 | Conduit Carrier |
| 919 | 11 | Drawer Unit |
| 2255NH | 22 | Locksmith Pkg - High Roof |
| 2255NS | 22 | Locksmith Pkg - Std Roof |
| 4484 | 18 | Cargo Mgmt Pkg - Std Roof |
| 4519 | 18 | Cargo Mgmt Pkg - High Roof |
| 4686NH | 19 | Gen Svc Pkg - NV High Roof |
| 4686NS | 19 | Gen Svc Pkg - NV Std Roof |
| 4687NH | 20 | Elect Pkg - NV High Roof |
| 4687NS | 20 | Elect Pkg - NV Std Roof |
| 4688NH | 20 | Security Pkg - NV High Roof |
| 4688NS | 20 | Security Pkg - NV Std Roof |
| 4689NH | 21 | Cable Pkg - NV High Roof |
| 4689NS | 21 | Cable Pkg - NV Std Roof |
| 4690NH | 21 | HVAC Pkg - NV High Roof |
| 4690NS | 21 | HVAC Pkg - NV Std Roof |

ADRIAN STEEL COMPANY



QUALITY

- Adrian Steel is proud to be the first and only van equipment manufacturer to obtain TS16949 certification.
- Our products are durable and reliable. Warranty claims are less than 1% of sales.
- Our warranty covers our products for three years or 36,000 miles.

INNOVATIVE PRODUCTS WITH FEATURES THAT MATTER

- Drawers that stay closed while in transit.
- ADseries truly adjustable shelving platform.
- LoadsRite drop-down ladder racks that load and unload the safe and right way.
- Interior ladder storage.
- Plug and Play accessories.
- File storage, removable small parts bins, and much more!



COMMITMENT

- At Adrian Steel, we are committed to you beyond the upfit!
 - A dedicated Customer Care Team at corporate headquarters.
 - A network of highly qualified distributors to support you locally.
 - Our commitment to provide the best cargo management solutions in North America.

EXPERIENCE

- Over One Million vans upfitted, and counting! It's a fact that an organized vehicle increases work flow efficiencies and reduces inventory damages.
- Recognized as a National Truck Equipment Association MVP.



SERVICE

- Adrian Steel Products can be purchased throughout North America at authorized Adrian Steel distributors.
- Adrian Steel Customer Service Representatives are available M-F, 8am - 5pm EST at **1-800-677-2726**.
- E-mail us at info@adriansteel.com with questions, comments and feedback.
- Visit AdrianSteel.com for the most up-to-date product information, distributor locator, product catalogs, videos and more.

PROUDLY DISTRIBUTED BY:



906 James Street, Adrian, Michigan 49221-3996
517-265-6194 Fax: 517-265-5834
Toll Free 800-677-2726
adriansteel.com info@adriansteel.com